

**ELITE™** SERIES

## Free-Standing EPA Certified Wood-Burning Stoves

Retain These Instructions  
For Future Reference

P/N 775,080M, Rev. G, 09/2007



Model CI2000HT Shown

## Spectra™ Series Wood Stoves Models CI1000HT and CI2000HT

A French manual is available upon request. Order P/N 775,080CF.

Ce manuel d'installation est disponible en français, simplement en faire la demande. Numéro de la pièce 775,080CF.

These appliances must be properly installed and operated in order to prevent the possibility of a house fire. Please read this entire installation and operation manual before installing and using your wood stove. Failure to follow these instructions could result in property damage, bodily injury or even death. Contact your local building or fire officials to obtain a permit and information on any installation requirements and inspection requirements in your area.



[www.nficertified.org](http://www.nficertified.org)

We recommend that our woodburning hearth products be installed and serviced by professionals who are certified in the U.S. by the National Fireplace Institute® (NFI) as NFI Woodburning Specialists or who are certified in Canada by Wood Energy Technical Training (WETT).



Tested & Listed By  Beaverton Oregon USA  
OMNI-Test Laboratories, Inc.  
CI1000HT Report #132-S-03-2  
CI2000HT Report #132-S-05-2



### **WARNINGS**

- **Hot! Do not touch!** The glass and surfaces of this appliance will be hot during operation and will retain heat for a while after shutting off the appliance. Severe burns may result.
- **Carefully supervise children** in the same room as appliance.

## IMPORTANT SAFETY AND WARNING INFORMATION

READ THIS MANUAL IN ITS ENTIRETY AND UNDERSTAND THESE RULES TO FOLLOW FOR SAFETY.

### CAUTION

Read this manual thoroughly before starting installation. For your safety, follow the installation, operation and maintenance instructions exactly without deviation. Failure to follow these instructions may result in a possible fire hazard and will void the warranty. If this appliance is not properly installed, a house fire may result. Contact local building or fire officials about requirements and installation inspection in your area.

### WARNING

Improper installation, adjustment, alteration, service or maintenance can cause injury or property damage. Refer to this manual. For assistance or additional information consult a qualified installer, service agency or the gas supplier.

### WARNING

Do not attempt to alter or modify the construction of the appliance or its components. Any modification or alteration may void the warranty, certification and listings of this unit.

1. If utilizing an older chimney, it must be inspected for adequate serviceability. Refer to the heading Chimney Inspection on *Page 10* of this manual.
2. The minimum clearances must be maintained for all combustible surfaces. The following materials should be kept a minimum of 36 inches (914 mm) from the heater; furniture, carpet, drapes, clothing, wood, papers, etc. Do not store firewood within this clearance space. Failure to maintain clearances to all combustibles may result in a house fire.
3. This appliance requires floor protection as out-lined in this manual (see *Floor Protection* on *Pages 4 through 8*).
4. **WARNING:** improper installation, adjustment, alteration, service or maintenance can cause injury or property damage. This appliance must be properly installed or the listing will be void. Installations other than those specifically covered herein have not been confirmed by test and are not covered by the listing.
5. Minimum ceiling height must be 5 feet (measured from base of appliance to ceiling).
6. **DO NOT CONNECT THIS UNIT TO A CHIMNEY FLUE CONNECTED TO ANOTHER APPLIANCE.**
7. Do not connect this appliance to air ducts or any air distribution system.
8. **PREVENT CREOSOTE FIRE:** Inspect and clean chimney connector and chimney daily for creosote build-up until experience shows how often you need to clean to be safe

Under certain conditions of use, creosote buildup may occur rapidly. Be aware that the hotter the fire the less creosote is deposited, and weekly cleaning may be necessary in mild weather even though monthly cleaning may be enough in the coldest months. Using green or inadequately seasoned wood can greatly increase creosote buildup. Use dry wood to minimize creosote buildup.

9. **USE SOLID WOOD FUEL ONLY:** This appliance is approved for burning dry seasoned natural wood only. **CAUTION: BURN UNTREATED WOOD ONLY. DO NOT BURN GARBAGE OR FLAMMABLE FLUIDS SUCH AS GASOLINE, NAPHTHA OR ENGINE OIL.**
10. Never use gasoline, gasoline-type lantern fuel, kerosene, charcoal lighter fluid, or similar liquids to start or "freshen up" a fire in this heater. Keep all such liquids well away from the heater while it is in use.
11. **DO NOT OVERFIRE:** If heater or chimney connector glows, you are overfiring. Overfiring this appliance could cause a house fire. Overfiring is a condition where the appliance is operated at temperatures above its design capabilities. Overfiring can be caused by improper installation, improper operation, lack of maintenance or improper fuel usage. Do not operate the stove with the doors open or ajar, as this will produce extreme temperatures within the stove. Damage caused from overfiring is NOT covered under the manufacturers limited warranty (see *Care and Operation* section on *Pages 14 through 18*).
12. **NEVER LEAVE AN UNATTENDED STOVE BURNING ON HIGH.** Operation of the stove with the primary air draft control at its highest burn rate setting for extended periods can cause dangerous overfiring conditions. The primary air draft control should only be positioned at the highest setting during start-up procedures (see *How to Start and Maintain a Fire* on *Page 15*) and for short durations. When leaving the stove unattended ensure that the primary air draft control is set to the low or medium low range.
13. It is imperative that the control compartments and circulating air passageways of the appliance be kept clean.
14. Use a metal container with a tight fitting lid to dispose of ashes.
15. **IN THE EVENT OF A COMPONENT FAILURE, USE ONLY COMPONENTS PROVIDED BY THE MANUFACTURER AS REPLACEMENT PARTS.**
16. Burning any kind of fuel uses oxygen from the dwelling. Be sure that you allow an adequate source of fresh air into the room where the stove is operating (see *Ventilation Requirements* on *Page 12*).
17. **CAUTION: HOT WHILE IN OPERATION.** An appliance hot enough to warm your home can severely burn anyone touching it. Keep children, clothing and furniture away. Contact may cause skin burns. Do not let children touch the appliance. Train them to stay a safe distance from the unit. The use of a fireguard is recommended.
18. Do not operate this appliance without the firebox baffle brick properly installed.
19. Always build wood fires directly on the firebox grate. Do not use andirons or any other method to elevate the fire.
20. Do not install these appliances into a Manufactured (Mobile) Home.
21. See the listing label located on the back of stove (or see *Safety/Listing Labels* on *Pages 32 & 33*).
22. These appliances are designed as supplemental heaters. Therefore, it is advisable to have an alternate heat source when installed in a dwelling.
23. **SAVE THESE INSTRUCTIONS.** Ensure that this manual remains with the appliance and passed to the user after installation.

## CONGRATULATIONS!

When you purchased your new wood stove, you joined the ranks of thousands of concerned individuals whose answer to their home heating needs reflects their concern for aesthetics, efficiency and our environment. We extend our continued support to help you achieve the maximum benefit and enjoyment available from your new wood stove.

It is our goal at Lennox to provide you, our valued customer, with an appliance that will ensure you years of trouble free warmth and pleasure.

Thank you for selecting a Lennox stove as the answer to your home heating needs.

Sincerely,  
All of us at Lennox Hearth Products

## TABLE OF CONTENTS

Important Warnings	Page 2
Testing/Listing, EPA	Page 3
Packaging List	Page 3
Using this Manual	Page 3
Planning Your Installation	Page 3
Clearances - C11000HT	Page 8
Clearances - C12000HT	Page 9
Installation	Page 10
Care and Operation	Page 14
Recommended Fuel / Wood Storage	Page 18
Maintenance	Page 19
Troubleshooting	Page 21
Specifications - C11000HT	Page 22
Specifications - C12000HT	Page 23
Replacement Parts List	Page 24
Optional Accessories	Page 31
Safety/Listing Label - C11000HT	Page 32
Safety/Listing Label - C12000HT	Page 33
EPA Labels	Page 34
Service and Maintenance Log	Page 35
Product Reference Information	Page 36

This installation and operation manual will help you obtain a safe, efficient, dependable installation for your appliance and vent system.

### PLEASE READ AND UNDERSTAND THESE INSTRUCTIONS BEFORE BEGINNING YOUR INSTALLATION

#### TESTING / LISTING

Models C11000HT and C12000HT have been Listed to UL Standard #1482 and ULC-S627 by OMNI-Test Laboratories, Inc.; Beaverton, OR; Report numbers; C11000HT #132-S-03-2 and C12000HT #132-S-05-2.

#### EPA (Environmental Protection Agency)

This heater meets EPA particulate matter (smoke) control requirements for noncatalytic wood heaters built on or after July 1, 1990.

#### PACKAGING LIST

The assembled wood stove models C11000HT and C12000HT are packaged with an accessory package which contains the following:

- One - Installation and Operation Manual
- One - Warranty Certificate
- One - Wood and Brass, Removable Door Handle (for opening the ashpan door, firebox door and side door)
- One - Air Control / Ash Pan Removal Tool
- One - Fire Poker
- Four - Leg Cushions
- One - Spray Can of Charcoal Paint

#### USING THIS MANUAL

Please read and carefully follow all of the instructions found in this manual. Please pay special attention to the safety instructions provided in this manual. The homeowner's care and operation Instructions included here will assure you have many years of dependable and enjoyable service from your appliance.

#### PRODUCT IS SUBJECT TO CHANGE WITHOUT NOTICE

#### PLANNING YOUR INSTALLATION

##### Questions To Ask Local Building Official

A correct installation is critical and imperative for reducing fire hazards and perilous conditions that can arise when wood burning appliances are improperly installed. The installer must follow all of the manufacturers' instructions. These models are designed as radiant room heaters and should be used for no other purpose.

The installation of a wood burning appliance must conform to local codes and applicable state and federal requirements and a building permit must be obtained before installing. Familiarity with these requirements before installation is essential. Important considerations to discuss with local building officials include:

1. **Applicable codes** (i.e. Uniform Mechanical Code, State or Regional Codes.)?
2. Local amendments?
3. Is a permit required - cost?  
(You may wish to contact your insurance company to ask if they require this?).
4. Rooms where the installation is not allowed?

##### Smoke Detectors

Since there are always several potential sources of fire in any home, we recommend installing smoke detectors. If possible, install the smoke detector in a hallway adjacent to the room (to reduce the possibility of occasional false activation from the heat produced by these appliances). If your local code requires a smoke detector be installed within the same room, you must follow the requirements of your local code. Check with your local building department for requirements in your area.

##### Installation / Solid Fuel Standards

National Fire Protection Association – The primary NFPA standard that refers to installation and maintenance of wood fired appliances and venting is NFPA 211 – Latest Edition: Chimneys, Fireplaces, Vents, and Solid Fuel Appliances.

**Note – This appliance is NOT approved for installation into a Manufactured Home.**

## SELECTING A LOCATION

The design of your home and where you place your stove will determine its value as a source of heat. This type of appliance depends primarily on air circulation (convection) to disperse its heat, and therefore, a central location is often best. There are other practical considerations, which must be considered before a final selection of locations is made.

- Existing Chimneys
- Wood Storage
- Aesthetic Considerations
- Roof Design (rafter locations & roof pitch)
- Room Traffic
- Proximity to Combustibles

The installation of these appliances will require some research. Once your options are determined, consult with your local building department who will be able to give you the necessary installation requirements for your area (Is a building permit required? Rooms where installation may not be allowed, etc.).

## WARNING

**Check all local building and safety codes before installation. The installation instructions and appropriate code requirements must be followed exactly and without compromise. Alterations to the stove are not allowed. Do not connect the stove to a chimney system serving another stove, appliance, or any air distribution duct. Failure to follow these instructions will void the manufacturers warranty.**

If you plan to vent your stove into an existing masonry chimney, have it inspected by a local fire marshal or qualified installer. Remember that a stove's performance is heavily influenced by the chimney and its location on the roof. An oversized flue may not provide effective draw, and a flue liner may be required (see *Draft Requirements* on **Page 11**). Consult your dealer or qualified installer before final selection is made.

This stove requires pre-installation work to be completed before installation can take place. This may include modification for flue and chimney.

The appliance should be inspected before use and the chimney cleaned at least annually. More frequent cleaning may be required due to poor operation, installation, or low quality fuel.

## CAUTION

**The body of these appliances are very heavy. The use of a heavy duty escalara (stair step hand truck) is recommended for lifting the appliance body.**

### Floor Protection - Model CI1000HT (USA ONLY)

The floor protector must meet or exceed the minimum thermal requirements as defined here (see *Floor Protection / Hearth Extension Using Alternate Material As Floor Protector*). If the floor protection is to be stone, tile, brick, etc., it must be mortared or grouted to form a continuous noncombustible surface. If a chimney connector extends horizontally over the floor, protection must also cover the floor under the connector and at least 2" (51 mm) to either side.

The floor protector must fully cover the area beneath the appliance and extend 18" to the front, 5.2" to the sides, and 0" from the back as shown in **Figure 1**.

#### For Floor Protection Material Requirements:

In USA see **Page 5**

In Canada see **Page 6**

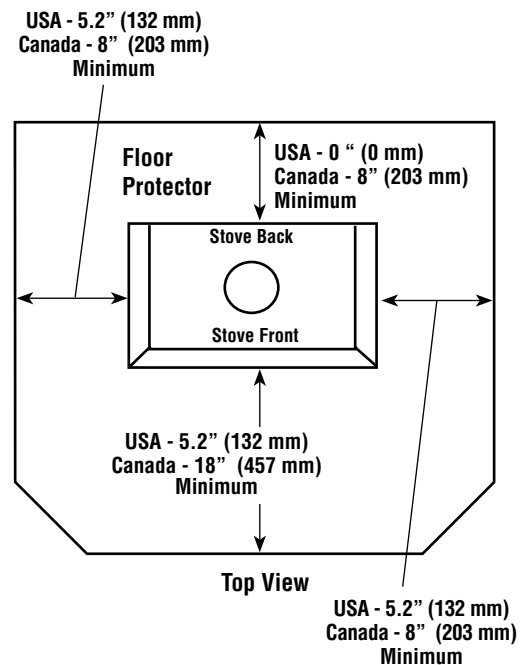

**Figure 1 - Floor Protection Requirements, Model CI1000HT**

## Floor Protection / Hearth Extension Using Alternate Material As Floor Protector - Model C11000HT (USA only)

*Note: Also see Floor Protection above .*

The hearth pad or alternate material used as a floor/hearth protector must be constructed of a durable noncombustible material having an equal or better thermal conductivity value (lower k value) of  $k = .84$  BTU/IN FT<sup>2</sup> HR °F or a thermal resistance that equals or exceeds  $r = 1.19$  HR °F FT<sup>2</sup> IN/BTU with a minimum thickness of 1/2". With these values, determine the minimum thickness of the alternate material required using the formula(s) and shown in **Table 1**.

**Note:** Any noncombustible material having a minimum thickness of 1/2" (13 mm) whose k value is less than .84 or whose r value is more than 1.19 is acceptable. If the alternate material used has a higher k value or lower r value will require a greater thickness of the material used. In some cases, if the k value is less or the r value higher, a thinner material may be used.

### Methods of determining floor protection equivalents:

To determine the thickness required for the alternate material when either the "k" value or "r" value is known, use either the **k formula** or **r formula**.

**Example:** If Durock™ Cement Board is to be used for the floor protection, how thick must this material be?

$k_M$  = k value per inch of **alternate** material

$r_M$  = r value per inch of **alternate** material

$T_M$  = minimum thickness required for **alternate** material

$T_S$  = standard thickness of the **alternate** material

$k_L$  = k value per inch of **listed** material

$r_L$  = r value per inch of **listed** material

$T_L$  = minimum thickness of **listed** material

**Note:** An asterisk "\*" indicates, it is a value taken from **Table 1**.

### Using the k formula:

$$\begin{aligned} \text{Minimum thickness of alternate material (T}_M\text{)} &= \frac{\text{k-value (per Inch) of alternate material (k}_M\text{)}}{\text{k-value (per inch) of listed material (k}_L\text{)}} \times \text{Specified min. thickness of listed material (T}_L\text{)} \\ T_M \text{ (inches)} &= \frac{k_M}{*.84} \times T_L \\ T_M \text{ (inches)} &= \frac{*1.92}{*.84} \times .5" \\ 1.143 \text{ (inches)} &= 2.286 \times .5" \end{aligned}$$

**Answer - The minimum required thickness of the Durock is 1.143" therefore round up to nearest standard thickness available which is 1-1/4."**

### Using the r formula:

$$\begin{aligned} \text{Minimum thickness of alternate material (T}_M\text{)} &= \frac{\text{r-value (per Inch) of listed material (r}_L\text{)}}{\text{r-value (per inch) of alternate material (r}_M\text{)}} \times \text{Specified min. thickness of listed material (T}_L\text{)} \\ T_M \text{ (inches)} &= \frac{r_L}{r_M} \times T_L \\ T_M \text{ (inches)} &= \frac{1.19}{*.52} \times .5" \\ 1.144 \text{ (inches)} &= 2.288 \times .5" \end{aligned}$$

**Answer - The minimum required thickness of the Durock is 1.143" therefore round up to nearest standard thickness available which is 1-1/4."**

Listed Material			
	k (per inch)	r (per inch)	Listed Min. Thickness
Listed Material	.84 $k_L$	1.19 $r_L$	1/2" (.5") $T_L$
** Approved Alternate Materials for Floor/Hearth Protection			
Alternative Materials	Thermal Values		Minimum Thickness (rounded to nearest 1/8 inch)
	k (per inch) $k_M$	r (per inch) $r_M$	Min. Thickness $T_M$
Kaowool M Board	.47	2.13	.28" (1/4")
Micore 160™ U.S. Gypsum	.35	2.86	.21" (1/4")
Micore 300™ U.S. Gypsum	.46	2.17	.27" (1/4")
Durock™ Cement Board U.S. Gypsum	1.92	.52	1.14" (1-1/8")
Hardibacker™	1.95	.51	1.16" (1-1/8")
Hardibacker 500™	2.30	.43	1.37" (1-3/8")
Cultured Stone Hearth-stone™	2.82	.35	1.68" (1-5/8")
Wonderboard	3.23	.31	1.92" (1-7/8")
Super Firetemp M Johns-Manville	.61	1.64	.36" (3/8")
Super Firetemp L Johns-Manville	.54	1.85	.32" (3/8")
Face brick	9.00	.111	5.36" (5-3/8")
Common brick	5.00	.20	2.98" (3")
Cement mortar	5.00	.20	2.98" (3")
Ceramic tile	12.5	.08	7.44" (7-1/2")
Marble	~11	~.09	6.55" (6-1/2")

**Table 1**

**\*\* If the hearth extension material(s) that is intended to be used is NOT listed on Table 1, the material can still be used if the material(s) is noncombustible. However, the manufacturer of the material must provide either the listed k-value per inch or r-value per inch with listed thickness so that the minimum thickness required for the hearth can be calculated (per instructions on this Page and/or as specified in the NFI Certification Manuals).**

**Note: Also see NFI (National Fireplace Institute) Certification Manuals showing other acceptable calculation methods and acceptable alternate materials which can be used.**

## Floor Protection / Hearth Extension Using Alternate Material As Floor Protector - Model C11000HT (Canada only)

**Note:** Also see Floor Protection above .

The hearth pad or alternate material used as a floor/hearth protector must be constructed of a durable noncombustible material having an equal or better thermal conductivity value (lower k value) of  $k = .84$  BTU/IN FT<sup>2</sup> HR °F or a thermal resistance that equals or exceeds  $r = 1.19$  HR °F FT<sup>2</sup> IN/BTU with a minimum thickness of 1/2". With these values, determine the minimum thickness of the alternate material required using the formula(s) and shown in **Table 2**.

**Note:** Any noncombustible material having a minimum thickness of 1/2" (13 mm) whose k value is less than .84 or whose r value is more than 1.19 is acceptable. If the alternate material used has a higher k value or lower r value will require a greater thickness of the material used. In some cases, if the k value is less or the r value higher, a thinner material may be used.

### Methods of determining floor protection equivalents:

To determine the thickness required for the alternate material when either the "k" value or "r" value is known, use either the **k formula** or **r formula**.

**Example:** If Durock™ Cement Board is to be used for the floor protection, how thick must this material be?

$k_M$  = k value per inch of **alternate** material  
 $r_M$  = r value per inch of **alternate** material  
 $T_M$  = minimum thickness required for **alternate** material  
 $T_S$  = standard thickness of the **alternate** material

$k_L$  = k value per inch of **listed** material  
 $r_L$  = r value per inch of **listed** material  
 $T_L$  = minimum thickness of **listed** material

**Note:** An asterisk "\*" indicates, it is a value taken from **Table 2**.  
**Using the k formula:**

$$\begin{aligned} \text{Minimum thickness of alternate material } (T_M) &= \frac{\text{k-value (per inch) of alternate material } (k_M)}{\text{k-value (per inch) of listed material } (k_L)} \times \text{Specified min. thickness of listed material } (T_L) \\ T_M \text{ (inches)} &= \frac{k_M}{*.84} \times T_L \\ T_M \text{ (inches)} &= \frac{*1.92}{*.84} \times 1.45" \\ 1.143 \text{ (inches)} &= 2.286 \times 1.45" \end{aligned}$$

**Answer -** The minimum required thickness of the Durock is 3.31" therefore round up to nearest standard thickness available which is 3-5/16."

**Using the r formula:**

$$\begin{aligned} \text{Minimum thickness of alternate material } (T_M) &= \frac{\text{r-value (per inch) of listed material}}{\text{r-value (per inch) of alternate material}} \times \text{Specified min. thickness of listed material } (T_L) \\ T_M \text{ (inches)} &= \frac{r_L}{r_M} \times T_L \\ T_M \text{ (inches)} &= \frac{1.19}{*.52} \times 1.45" \\ 1.144 \text{ (inches)} &= 2.288 \times 1.45" \end{aligned}$$

**Answer -** The minimum required thickness of the Durock is 3.31" therefore round up to nearest standard thickness available which is 3-5/16."

Listed Material			
	k (per inch)	r (per inch)	Listed Min. Thickness
Listed Material	.84 $k_L$	1.19 $r_L$	1.45" (1-1/2") $T_L$
** Approved Alternate Materials for Floor/Hearth Protection			
Alternative Materials	Thermal Values		Minimum Thickness (rounded to nearest 1/8 inch)
	k (per inch) $k_M$	r (per inch) $r_M$	Min. Thickness $T_M$
Kaowool M Board	.47	2.13	.81" (3/4")
Micore 160™ U.S. Gypsum	.35	2.86	.60" (5/8")
Micore 300™ U.S. Gypsum	.46	2.17	.79" (3/4")
Durock™ Cement Board U.S. Gypsum	1.92	.52	3.31" (3-3/8")
Hardibacker™	1.95	.51	3.37" (3-3/8")
Hardibacker 500™	2.30	.43	3.97" (4")
Cultured Stone Hearth-stone™	2.82	.35	4.87" (4-7/8")
Wonderboard	3.23	.31	5.58" (5-5/8")
Super Firetemp M Johns-Manville	.61	1.64	1.05" (1")
Super Firetemp L Johns-Manville	.54	1.85	.93" (7/8")
Face brick	9.00	.11	15.54" (15-1/2")
Common brick	5.00	.20	8.63" (8-5/8")
Cement mortar	5.00	.20	8.63" (8-5/8")
Ceramic tile	12.5	.08	21.58" (21-5/8")
Marble	~11	~.09	18.99" (19")
<b>Table 2</b>			

\*\* If the hearth extension material(s) that is intended to be used is NOT listed on Table 2, the material can still be used if the material(s) is noncombustible. However, the manufacturer of the material must provide either the listed k-value per inch or r-value per inch with listed thickness so that the minimum thickness required for the hearth can be calculated (per instructions on this Page and/or as specified in the NFI Certification Manuals).

**Note:** Also see NFI (National Fireplace Institute) Certification Manuals showing other acceptable calculation methods and acceptable alternate materials which can be used.

## Floor Protection - Model CI2000HT (USA and Canada)

The floor protector must meet or exceed the minimum thermal requirements as defined on this Page (see *Floor Protection / Hearth Extension Using Alternate Material As Floor Protector*). If the floor protection is to be stone, tile, brick, etc., it must be mortared or grouted to form a continuous noncombustible surface. If a chimney connector extends horizontally over the floor, protection must also cover the floor under the connector and at least 2" (51 mm) to either side.

The floor protector must fully cover the area beneath the appliance and extend 18" to the front, 5"-USA and 8"-Canada to the sides, and 0"-USA and 8"-Canada from the back as shown in **Figure 2**.

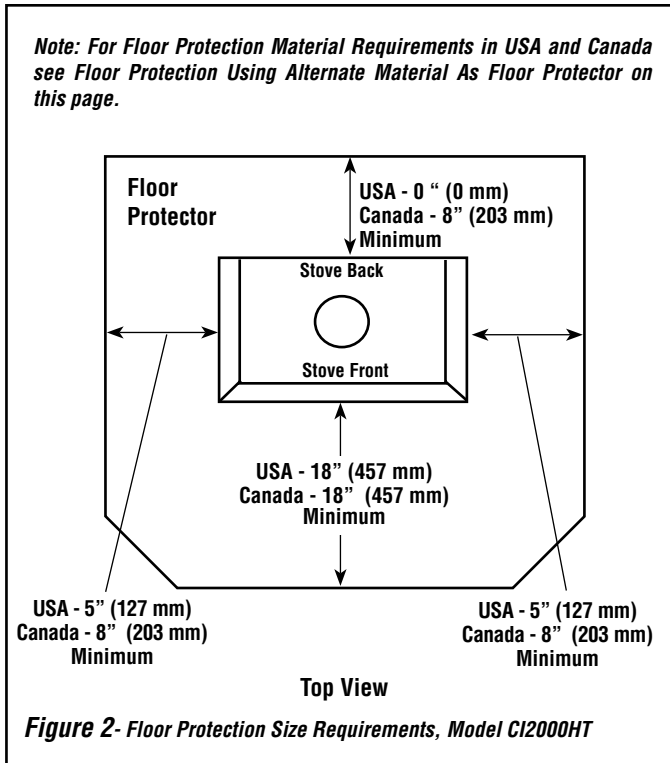

## Floor Protection / Hearth Extension Using Alternate Material As Floor Protector - Model CI2000HT (USA and Canada)

**Note:** Also see *Floor Protection* above .

The hearth pad or alternate material used as a floor/hearth protector must be constructed of a durable noncombustible material having an equal or better thermal conductivity value (lower k value) of  $k = .84$  BTU/IN FT<sup>2</sup> HR °F or a thermal resistance that equals or exceeds  $r = 1.19$  HR °F FT<sup>2</sup> IN/BTU with a minimum thickness of 1/2". With these values, determine the minimum thickness of the alternate material required using the formula(s) and shown in **Table 3**.

**Note:** Any noncombustible material having a minimum thickness of 1/2" (13 mm) whose k value is less than .84 or whose r value is more than 1.19 is acceptable. If the alternate material used has a higher k value or lower r value will require a greater thickness of the material used. In some cases, if the k value is less or the r value higher, a thinner material may be used.

### Methods of determining floor protection equivalents:

To determine the thickness required for the alternate material when either the "k" value or "r" value is known, use either the **k formula** or **r formula**.

**Example:** If Durock™ Cement Board is to be used for the floor protection, how thick must this material be?

$k_M$  = k value per inch of **alternate** material  
 $r_M$  = r value per inch of **alternate** material  
 $T_M$  = minimum thickness required for **alternate** material  
 $T_S$  = standard thickness of the **alternate** material

$k_L$  = k value per inch of **listed** material  
 $r_L$  = r value per inch of **listed** material  
 $T_L$  = minimum thickness of **listed** material

**Note:** An asterisk "\*" indicates, it is a value taken from **Table 3**.

### Using the k formula:

Minimum thickness of alternate material ( $T_M$ )	=	k-value (per Inch) of alternate material ( $k_M$ ) x k-value (per inch) of listed material ( $k_L$ )	x	Specified min. thickness of listed material ( $T_L$ )
$T_M$ (inches)	=	$\frac{k_M}{*.84}$	x	$T_L$
$T_M$ (inches)	=	$\frac{*1.92}{*.84}$	x	.5"
1.143 (inches)=		2.286	x	.5"

**Answer - The minimum required thickness of the Durock is 1.143" therefore round up to nearest standard thickness available which is 1-1/4."**

### Using the r formula:

Minimum thickness of alternate material	=	r-value (per Inch) of listed material x r-value (per inch) of alternate material	x	Specified min. thickness of listed material
$T_M$ (inches)	=	$\frac{r_L}{r_M}$	x	$T_L$
$T_M$ (inches)	=	$\frac{*1.19}{*.52}$	x	.5"
1.144 (inches)=		2.288	x	.5"

**Answer - The minimum required thickness of the Durock is 1.143" therefore round up to nearest standard thickness available which is 1-1/4."**

**Floor Protection - Model CI2000HT (USA and Canada)**  
Continued...

Listed Material			
	k (per inch)	r (per inch)	Listed Min. Thickness
Listed Material	.84 $K_L$	1.19 $r_L$	1/2" (.5") $T_L$
<b>** Approved Alternate Materials for Floor/Hearth Protection</b>			
Alternative Materials	Thermal Values		Minimum Thickness (rounded to nearest 1/8 inch)
	k (per inch) $K_M$	r (per inch) $r_M$	Min. Thickness $T_M$
Kaowool M Board	.47	2.13	.28" (1/4")
Micore 160™ U.S. Gypsum	.35	2.86	.21" (1/4")
Micore 300™ U.S. Gypsum	.46	2.17	.27" (1/4")
Durock™ Cement Board U.S. Gypsum	1.92	.52	1.14" (1-1/8")
Hardibacker™	1.95	.51	1.16" (1-1/8")
Hardibacker 500™	2.30	.43	1.37" (1-3/8")
Cultured Stone Hearth-stone™	2.82	.35	1.68" (1-5/8")
Wonderboard	3.23	.31	1.92" (1-7/8")
Super Firetemp M Johns-Manville	.61	1.64	.36" (3/8")
Super Firetemp L Johns-Manville	.54	1.85	.32" (3/8")
Face brick	9.00	.111	5.36" (5-3/8")
Common brick	5.00	.20	2.98" (3")
Cement mortar	5.00	.20	2.98" (3")
Ceramic tile	12.5	.08	7.44" (7-1/2")
Marble	~11	~.09	6.55" (6-1/2")

**Table 3**

**\*\* If the hearth extension material(s) that is intended to be used is NOT listed on Table 3, the material can still be used if the material(s) is noncombustible. However, the manufacturer of the material must provide either the listed k-value per inch or r-value per inch with listed thickness so that the minimum thickness required for the hearth can be calculated (per instructions on this Page and/or as specified in the NFI Certification Manuals).**

**Note: Also see NFI (National Fireplace Institute) Certification Manuals showing other acceptable calculation methods and acceptable alternate materials which can be used.**

**CLEARANCES - MODEL CI1000HT**

**COMBUSTIBLE WALL CLEARANCE – USA & Canada**

**WARNING: It is very important that you observe the minimum clearances.**

There are listed clearances for your stove which were determined in a Laboratory test using various “classes” of stove pipe or chimney. Minimums are first established for the stove itself and increased based on how much heat is transferred by each class of pipe.

Position the unit no closer than the minimum clearances to combustible materials. Check that no overhead cross members in the ceiling or roof will be cut. Reposition unit if necessary being careful not to move closer than the minimum clearances.

Minimum Ceiling Height – 7 feet / 2133mm from floor to ceiling.

**Single Wall Pipe Without Pipe Shield - CI1000HT**

Using single wall 24 MSG black or 25 MSG blued steel connector pipe with factory-built chimney listed to either UL 103HT or ULC S629.

Minimum Clearances to Combustibles - inches (millimeters)			
A	27-1/2" (699 mm)	D	24" (610 mm)
B	27" (686 mm)	E	18" (457 mm)
C	27" (686 mm)	F	19" (483 mm)
G	35-3/16" (894 mm) <i>This is a reference dimension only</i>		

**Table 4 - Model CI1000HT (see Figures 3 and 4)**

**Single Wall Pipe With Pipe Shield / Reduced Clearance - CI1000HT**

Using single wall 24 MSG black or 25 MSG blued steel connector pipe with factory-built chimney listed to either UL 103HT or ULC S629. The use of a pipe shield for 6" connector with 1" clearance to the pipe is mandatory.

Minimum Clearances to Combustibles - inches (millimeters)			
A	21-1/2" (546 mm)	D	18" (457 mm)
B	27" (686 mm)	E	18" (457 mm)
C	19" (483 mm)	F	11" (279 mm)
G	23-7/8" (606 mm) <i>This is a reference dimension only</i>		

**Table 5 - Model CI1000HT (see Figures 3 and 4)**

**Protected Wall Clearance - CI1000HT and CI2000HT**

Some local codes will allow reduced clearances when the stove is installed adjacent to a protected wall system. The variance must be approved by your local building official. Normally, the protected wall system is defined as a non-combustible material with a minimum of 1" air space behind. Check your local building codes or with a qualified installer (Ref. NFPA 211).



## CLEARANCES - MODEL CI2000HT

### COMBUSTIBLE WALL CLEARANCE – USA & Canada

**WARNING: It is very important that you observe the minimum clearances.**

There are listed clearances for your stove which were determined in a Laboratory test using various “classes” of stove pipe or chimney. Minimums are first established for the stove itself and increased based on how much heat is transferred by each class of pipe.

Position the unit no closer than the minimum clearances to combustible materials. Check that no overhead cross members in the ceiling or roof will be cut. Reposition unit if necessary being careful not to move closer than the minimum clearances.

### Single Wall Pipe - CI2000HT

(Not approved for alcove installations)

Using single wall 24 MSG black or 25 MSG blue steel connector pipe with factory-built chimney listed to either UL 103HT or ULC S629.

Minimum Clearances to Combustibles - inches (millimeters)			
A	18" (457 mm)	D	13" (330 mm)
B	32" (813 mm)	E	20" (508 mm)
C	27" (686 mm)	F	16" (406 mm)
G	35-3/16" (894 mm) <i>This is a reference dimension only</i>		

**Table 6 (see Figures 3 and 4)**

### Double Wall Pipe - CI2000HT

(For alcove installations, clearances “C” and “F” are not applicable) Use listed double wall chimney connector or Type L vent pipe to the top of the stove.

Minimum Clearances to Combustibles - inches (millimeters)			
A	14-1/2" (368 mm)	D	10" (254 mm)
B	28-1/2" (724 mm)	E	17" (432 mm)
C	18" (457 mm)	F	7" (178 mm)

**Table 7 (see Figures 3 and 4)**

Minimum Ceiling Height for Single wall pipe and double wall pipe installations and Alcove Installations – 60" (1524 mm) from floor to ceiling and 29" (737 mm) from stove top to ceiling.

### Alcove Installation Clearances - CI2000HT

Alcove Installations Require Double Wall Pipe Only

Use listed double wall chimney connector or Type L vent pipe to the top of the stove.

Minimum Clearances to Combustibles - inches (millimeters)			
A	14-1/2" (368 mm)	D	10" (254 mm)
B	28-1/2" (724 mm)	E	17" (432 mm)
C	N/A	F	N/A

**Table 8 (see Figures 3 and 4)**

**Note:** Alcove clearances cannot be reduced using wall protection. Maximum alcove depth must be no more than 48" (1220 mm).

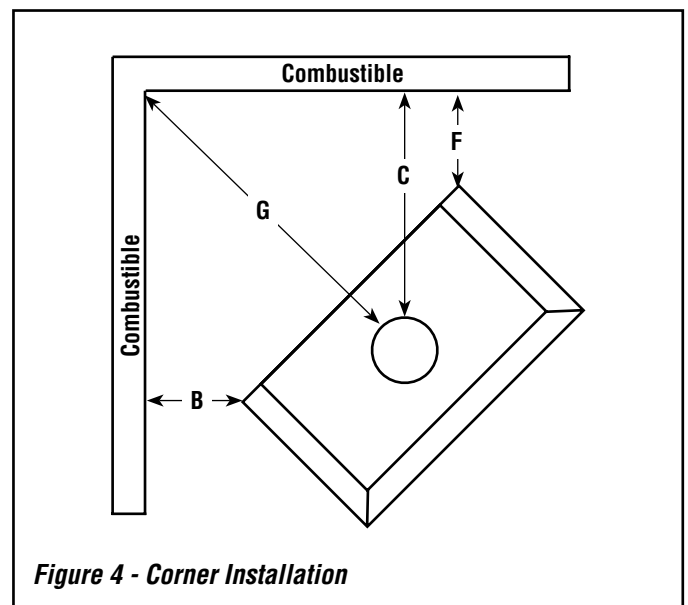
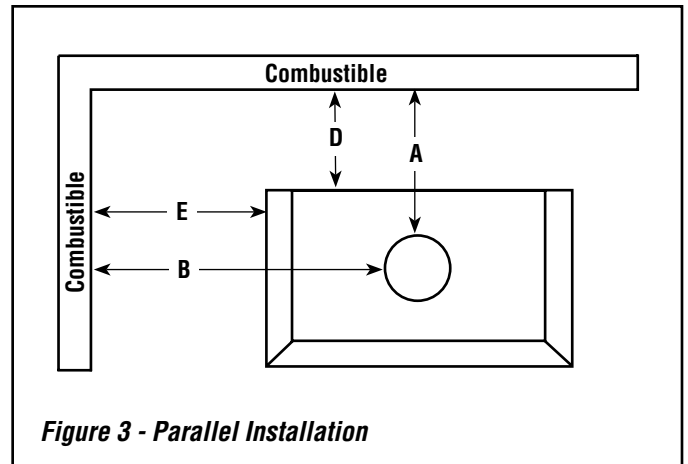

**MODEL CI1000HT IS NOT APPROVED FOR USE WITH DOUBLE WALL PIPE.**

**DO NOT INSTALL THE CI1000HT INTO AN ALCOVE OR A CONFINED SPACE.** This unit has not been tested or approved for installation into a confined space such as an alcove (see the national standard below).

**NFPA 211- latest edition: (Applies to Solid Fuel Burning Appliances, which are not alcove tested) - Solid fuel-burning appliances shall not be installed in confined spaces. The space or room shall be of ample size to allow adequate circulation of heated air. Appliances shall be so located as not to interfere with the proper circulation of air within the heated space.**

### Installing Leg Pads

The four leg pads (included in accessory package), are provided for placement under the four legs.

## INSTALLATION

### Types of Chimneys

The unit must be connected to either a code-approved masonry chimney with a flue liner, or a 6 inch diameter factory-built chimney complying with the requirements for Type HT chimneys in the standard UL 103.

The chimney is a vital part of your stove installation. A properly built masonry chimney or a properly installed factory-built chimney will assure a consistent draft under a variety of weather conditions (a smoking stove is usually caused by a chimney problem). The stove flue size is 6 inches diameter, which is approximately 28 square inches minimum. The maximum flue size should be no more than three (3) times the cross sectional area of the size of the stove flue collar. In this case, that would be no larger than an 10-inch diameter stack, or approximately 85 square inches maximum.

All chimneys must be installed as specified by local building codes and according to the chimney manufacturer instructions (in the case of a factory-built chimney). See the chimney manufacturer instructions for exact specifications. Factory-built chimneys must comply with UL 103HT or ULC S629. A chimney connector shall not pass through an attic or roof space, closet or similar concealed space, or a floor, or ceiling. Where passage through a wall, or partition of combustible construction is desired, the installation shall conform to CAN/CSA-B365, Installation Code for Solid-Fuel-Burning Appliances and Equipment.

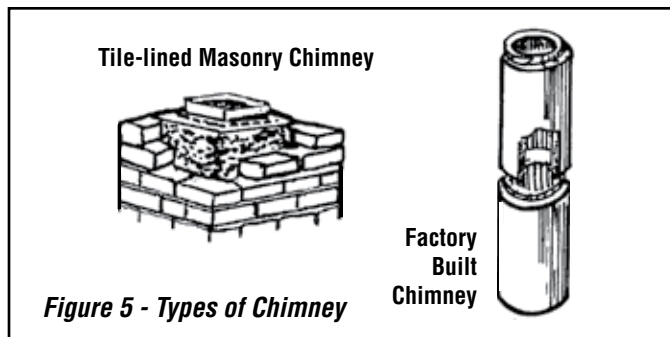

### Acceptable Connector Pipe For Installations

When Using Single Wall Pipe: Install a six (6) inch diameter, single wall, 24 MSG black steel or 26 MSG blued steel connector pipe on the flue collar of the unit. When installing pipe, the crimped ends of the pipe should all point down. Position all seams toward the back for aesthetics. Three (3) pre-drilled holes are provided in the flue collar for fastening the pipe securely to the stove. Use sheet metal screws to do this. Additional sections of single wall pipe should be fastened together with at least three (3) sheet metal screws each section. All pipe connections must be sealed (ie. high temperature silicone). When connecting to the factory-built ceiling support package, use the manufacturer's transition piece, usually called a dripless connector, to join single wall pipe to their factory-built chimney section.

### When Using Approved Double Wall Pipe (Approved for Model C1200HT Only)

Type L and listed double wall connector pipe is acceptable. Install any factory-built brand of pipe according to the manufacturer's instructions. All pipe connections must be sealed (ie. high temperature silicone).

### Minimum / Maximum Flue Diameter:

Minimum 6", Maximum 10"

### Chimney Connector Adapter

Use a chimney connector adapter to connect the chimney connector up to the chimney. The small ends of the chimney connector should all point down for a drip free installation. Position all seams toward the back for aesthetics. The chimney connector must be 6-inch diameter.

Secure adjoining sections of chimney connector to each other using three equally spaced sheet metal screws. Secure the connector pipe to flue collar using three equally spaced sheet metal screws. **DO NOT secure chimney connector to chimney with screws.**

### Connection To A Factory-built Chimney

This space heater is to be connected to a factory-built chimney conforming to CAN / ULC – S629, Standard for 650°C Factory-Built Chimneys. All pipe connections must be sealed (ie. high temperature silicone).

### For Reduced Residential Clearances Using Double Wall Pipe (Approved for Model C1200HT Only):

Type L and listed double wall connector pipe is acceptable. Install any factory-built brand of pipe according to the manufacturer's instructions.

### Vapor Barrier at Chimney Penetration

Install all venting components per the Vent Manufacturers installation instructions. Ensure that there is an effective vapor barrier at the location where the chimney penetrates to the exterior of the structure. This can be accomplished by applying a non-hardening waterproof sealant to the following components:

- Around the chimney at the point where the storm collar will meet the chimney just above the Flashing
- Along the vertical seam of the chimney pipe, where it is exposed to the weather.
- On each nail head on the flashing.
- Around the chimney at the point where the storm collar will meet the chimney just above the flashing.

### Notes:

- On a flat or tarred and graveled roofs, nail and seal the flat roof flashing to the roof on all sides with roofing compound.
- Do not put screws through the flashing into the chimney pipe.

### Chimney Inspection

Existing chimneys must be inspected before installing your stove. Consult your local building department for chimney code requirements. A masonry chimney must have a code approved liner. This liner must not have broken or missing pieces. Some non-code masonry chimneys may be brought up to code by being relined. (Consult your dealer or qualified chimney sweep). Factory-built chimneys should also be inspected, first for creosote deposits (which should be removed), and then for integrity of the stainless steel liner. Look for obvious bulges in the lining, which may indicate the need to replace that section (use a bright flashlight). Also, inspect the attic to see that the chimney has proper clearance to combustible framing members. For interior masonry chimneys and most factory-built chimneys, this must be a two (2) inch air space clearance, which must not be filled with insulation or any other material. An exterior masonry chimney must have a one (1) inch air space clearance.

## Chimney Height Requirements

The chimney must extend 3 feet above the level of roof penetration and a minimum of 2 feet higher than any roof surface within 10 feet (see below). Check with your local building officials for any additional requirements for your area.

Due to prevailing winds, local terrain, adjacent tall trees, a hill, or ravine near the home, or adjacent structures, additional chimney height or a special chimney cap may be required to ensure optimum performance.

See **Figure 6** for the 10' by 2' Rule for Vent Termination. The top of the flue must be 2' (610 mm) higher than any part of the roof within 10' (305 cm) horizontal and a minimum of 3' (915 mm) higher than the highest point of roof penetration.

### Important Note:

*The installation of a barometric damper is recommended for all free-standing stoves in areas that may have high winds, which can effect the draft. The installation must be only in units with a newly constructed chimney, free of creosote deposits. The barometric damper is an automatic device designed to regulate the draft in a heating appliance, which in turn, stabilizes the chimney temperatures, lessening the potential of over-firing. Do not place the barometric damper greater than 24 inches (610 mm) above the unit. Excessive draft will lead to poor control of the burning rate and possible over-firing of the stove and damage to the cast iron firebox. Most barometric dampers are calibrated in inches of water column and can be set to draft requirements of -.03 to -.08 inches (-7.5 to -20 Pa). It is recommended that the barometric dampers to be set between -.05 and -.06 inches.*

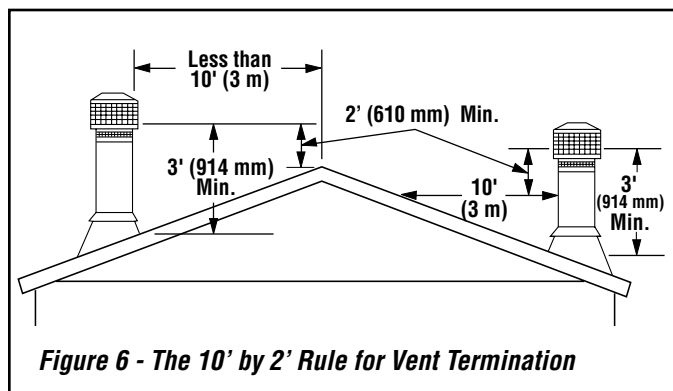

**THE RECOMMENDED DRAFT REQUIREMENTS FOR THESE APPLIANCES IS NO LESS THAN -.05 AND NO GREATER THAN -.06. OPERATION OF YOUR STOVE WITH A DRAFT GREATER THAN -.06 CAN POSSIBLY CAUSE DAMAGE TO THE STOVE AND VOID THE WARRANTY.**

Fire intensity is a function of several factors. One of these factors is DRAFT. Normally, increasing draft increases fire intensity. Conversely, increasing the fire intensity will increase draft. Draft can also be affected by external factors such as wind strength and direction, outside temperature, airflow in or out of the structure, and so forth. If one of these factors changes, the draft of a low-burning appliance may increase. This increased draft may cause dangerously high temperature to develop, possibly causing failure of the unit or flue, or ignition of nearby combustibles. Closing down the combustion airflow ("Primary Air Draft Control") may not guarantee that this will not happen.

## CAUTION

**Many structure fires have resulted when a slow burning fire has been left unattended for any extended period of time. These fires normally occur because combustible materials close to an appliance become heated to the ignition point by an overfired appliance which the operator thought was safety "throttled down."**

### Draft Requirements

The appliance is merely one component of a larger system. The other equally important component is the venting system which is necessary for achieving the required flow of combustion air to the fire chamber and for safely removing unwanted combustion by-products from the appliance. If the venting system's design does not promote these ends, the system may not function properly. Poorly functioning venting systems may create performance problems (i.e. smoking stove, poor heat output, fire goes out, window blackens, increased creosote buildup, etc.) as well as be a safety hazard. Some factors that may lead to performance problems are as follows:

- Oversized or undersized chimney.
- Excessive offsets in venting.
- Insufficient vertical height of chimney.
- Insufficient chimney termination height in relationship to roof.
- Insufficient ventilation.
- Lack of maintenance.
- Improper operation.
- Burning improper fuel (unit is approved for use with natural dry well-seasoned wood only).
- Down drafts in the chimney (may need a special wind cap).

To ensure that the venting system is functioning properly a draft test should be performed (see *Draft Test Procedure* on this page).

American National Standards Institute ANSI/NFPA 211-96: A chimney or vent shall be so designed and constructed to develop a flow sufficient to completely remove all flue and vent gases to the outside atmosphere. The venting system shall satisfy the draft requirements of the connected appliance in accordance with the manufacturer instructions.

### Draft Test Procedure

After this appliance is installed a draft test should be performed to ensure proper draft. A qualified technician should perform the draft test procedure as follows:

- 1) Close all windows and doors in the dwelling.
- 2) Turn on or operate all appliances which remove air from the home (such as a furnace, heat pump, air conditioner, clothes dryer, exhaust fans, fireplaces, and other fuel burning appliances).

- 3) Drill a hole in the vent pipe per the draft gauge manufacturers instructions (to create a draft test port). **Note:** Hole location should be a minimum of 1 foot above flue outlet collar.
- 4) Start a fire (See *How To Start And Maintain A Fire* on **Page 15**).
- 5) After the fire is well established (20-25 minutes) and burning at a low setting, perform the draft test per the gauge manufacturer instructions. The draft gauge should read between .05 and .06" W.C. (inches water column). Excessive draft (above .06 W.C.I.) can result in too much combustion air to be pulled into the firebox, this will produce hotter burns and could result in overfiring. Too little draft (below .05" W.C.) will not allow enough combustion air delivery to maintain a fire well or cause performance problems such as smoking (this may result in improper operation of appliance, i.e. will not maintain fire well unless fuel door is left open).
- 6) Install a screw to seal the draft test port in the vent pipe. If the draft test reading was not within the required range, correct the installation and repeat this procedure.

#### Ventilation Requirements / Provide Adequate Air For Combustion

**THE FRESH AIR REQUIREMENTS OF THIS APPLIANCE MUST BE MET WITHIN THE SPACE WHERE IT WILL BE INSTALLED. VENTILATION IS ESSENTIAL WHEN USING A SOLID FUEL BURNING HEATER.**

In well insulated and weather tight homes, it may be difficult to establish a good draft up the chimney (caused by a shortage of air in the home). The lack of air is caused by many common household appliances which exhaust air from the home (such as a furnace, heat pump, air conditioner, clothes dryer, exhaust fans, fireplaces, and other fuel burning appliances). Also, the combustion process of this heater uses oxygen from inside the dwelling. If the available fresh air delivery in the dwelling is insufficient to support the demands of these appliances, problems can result (i.e. excessive negative pressure can develop in the dwelling which will affect the rate at which this appliance can draft thus resulting in performance problems; See *Draft Requirements* on **Page 11**). To correct this problem it may help to open a window (preferably on the windward side of the house) or install a vent to provide make-up air into the dwelling.

#### Important Notes:

- Minimize the use of elbows (30°, 45° or 90°) - Offsets in the venting system are very restrictive and will inhibit the draft (i.e. You will lose approximately 5 feet of effective draft for every 90 degrees of direction change). This appliance requires 12 to 15 feet of effective draft for optimum performance (see *Draft Requirements* on **Page 11**).
- First section of pipe must be vertical - Use as much straight vertical pipe directly above the appliance as possible before using an elbow (a 2' to 3' initial vertical rise is suggested).
- See pipe manufacturers instructions for installation requirements of venting components and vent clearances.

#### Single Wall Pipe Using 6" Diameter Single Wall Connector Pipe

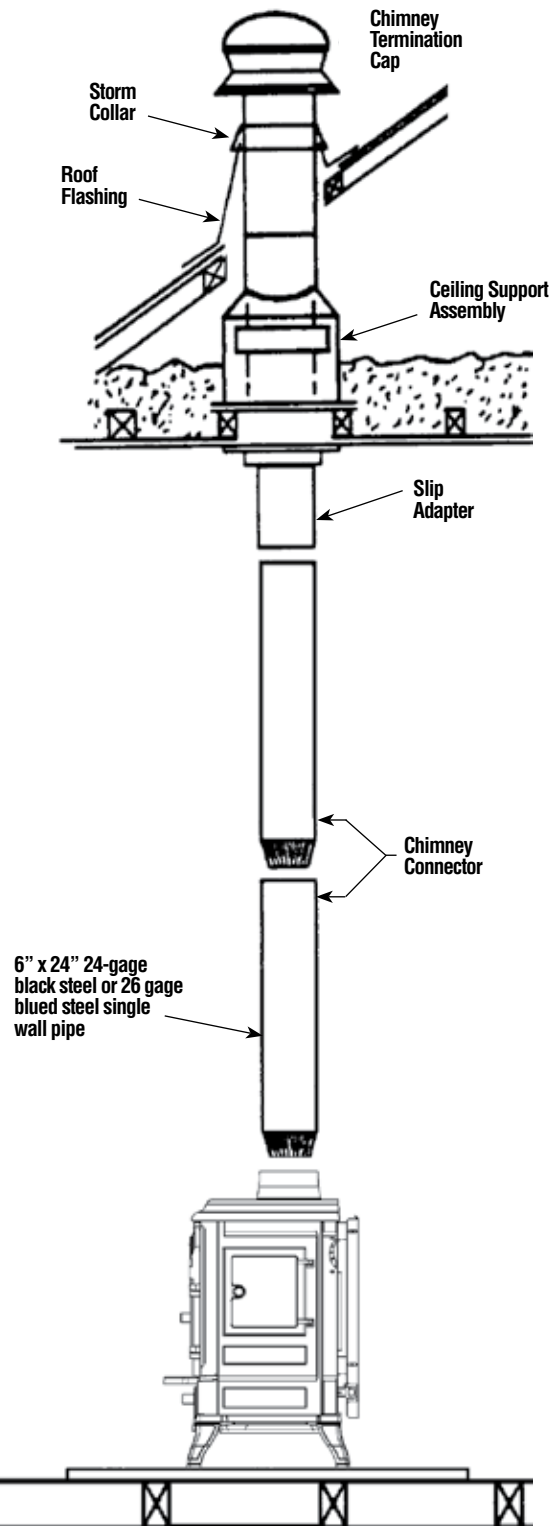

**Figure 7 - Single Wall Pipe**

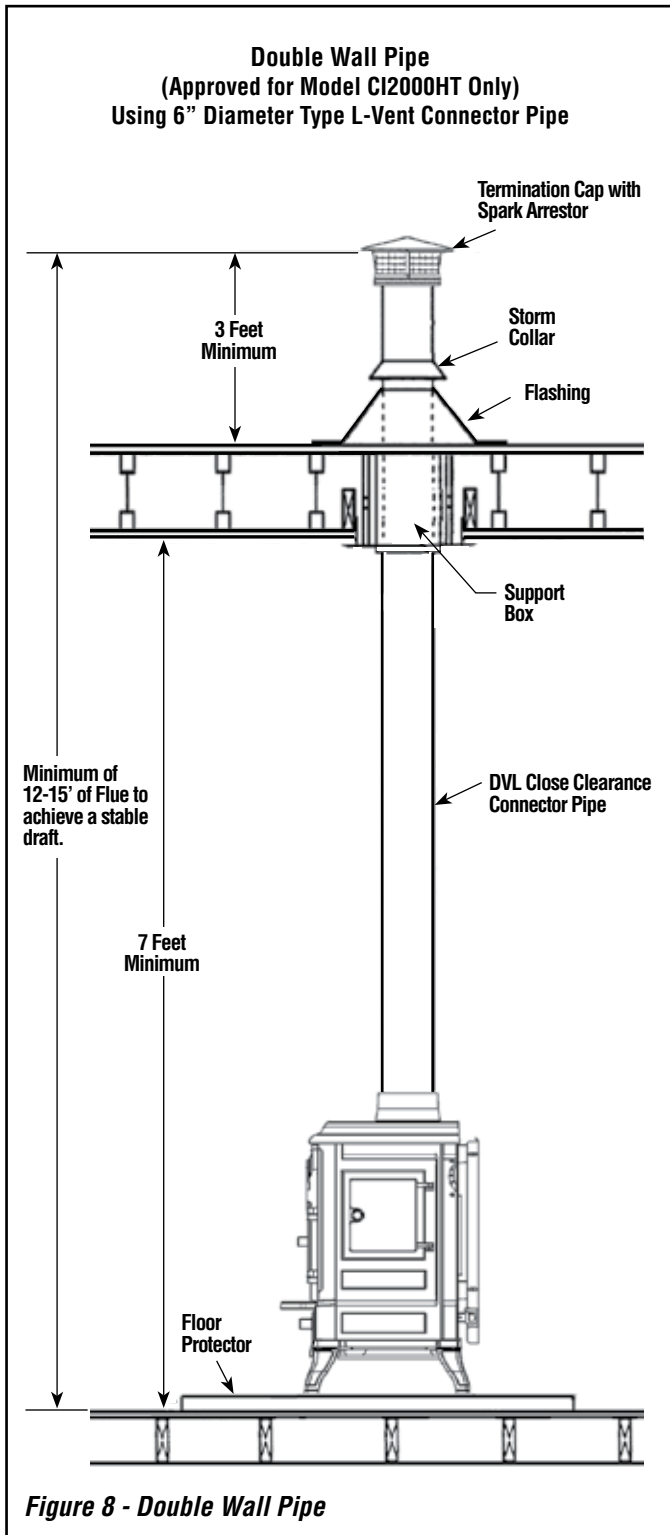

### Combustible Wall Chimney Connector Pass-Throughs

Refer to **Figure 9**

#### **Method A. 12" (305 mm) Clearance to Combustible Wall Member:**

Using a minimum thickness 3.5" (89 mm) brick and a 5/8" (16 mm) minimum wall thickness clay liner, construct a wall pass-through. The clay liner must conform to ASTM C315 (Standard Specification for Clay Fire Linings) or its equivalent. Keep a minimum of 12" (305 mm) of brick masonry between the clay liner and wall combustibles. The clay liner shall run from the brick masonry outer surface to the inner surface of the chimney flue liner but not past the inner surface. Firmly grout or cement the clay liner in place to the chimney flue liner.

#### **Method B. 9" (229 mm) Clearance to Combustible Wall Member:**

Using a 6" (153 mm) inside diameter, listed, factory-built Solid-Pak chimney section with insulation of 1" (26 mm) or more, build a wall pass-through with a minimum 9" (229 mm) air space between the outer wall of the chimney length and wall combustibles. Use sheet metal supports fastened securely to wall surfaces on all sides, to maintain the 9" (229 mm) air space. When fastening supports to chimney length, do not penetrate the chimney liner (the inside wall of the Solid-Pak chimney). The inner end of the Solid-Pak chimney section shall be flush with the inside of the masonry chimney flue, and sealed with a non-water soluble refractory cement. Use this cement to also seal to the brick masonry penetration.

#### **Method C. 6" (153 mm) Clearance to Combustible Wall Member:**

Starting with a minimum 24 gage (.024" [.61 mm]) 6" (153 mm) metal chimney connector, and a minimum 24 gage ventilated wall thimble which has two air channels of 1" (26 mm) each, construct a wall pass-through. There shall be a minimum 6" (153 mm) separation area containing fiberglass insulation, from the outer surface of the wall thimble to wall combustibles. Support the wall thimble, and cover its opening with a 24-gage minimum sheet metal support. Maintain the 6" (153 mm) space. There should also be a support sized to fit and hold the metal chimney connector. See that the supports are fastened securely to wall surfaces on all sides. Make sure fasteners used to secure the metal chimney connector do not penetrate chimney flue liner.

#### **Method D. 2" (51 mm) Clearance to Combustible Wall Member:**

Start with a solid-pak listed factory built chimney section at least 12" (304 mm) long, with insulation of 1" (26 mm) or more, and an inside diameter of 8" (2 inches [51 mm] larger than the 6" [153 mm] chimney connector). Use this as a pass-through for a minimum 24-gage single wall steel chimney connector. Keep solid-pak section concentric with and spaced 1" (26 mm) off the chimney connector by way of sheet metal support plates at both ends of chimney section. Cover opening with and support chimney section on both sides with 24 gage minimum sheet metal supports. See that the supports are fastened securely to wall surfaces on all sides. Make sure fasteners used to secure chimney section do not penetrate chimney flue liner.

1. Connectors to a masonry chimney, excepting method B, shall extend in one continuous section through the wall pass-through system and the chimney wall, to but not past the inner flue liner face.
2. A chimney connector shall not pass through an attic or roof space, closet or similar concealed space, or a floor, or ceiling.
3. Where passage through a wall, or partition of combustible construction is desired, the installation shall conform to CAN/CSA-B365.

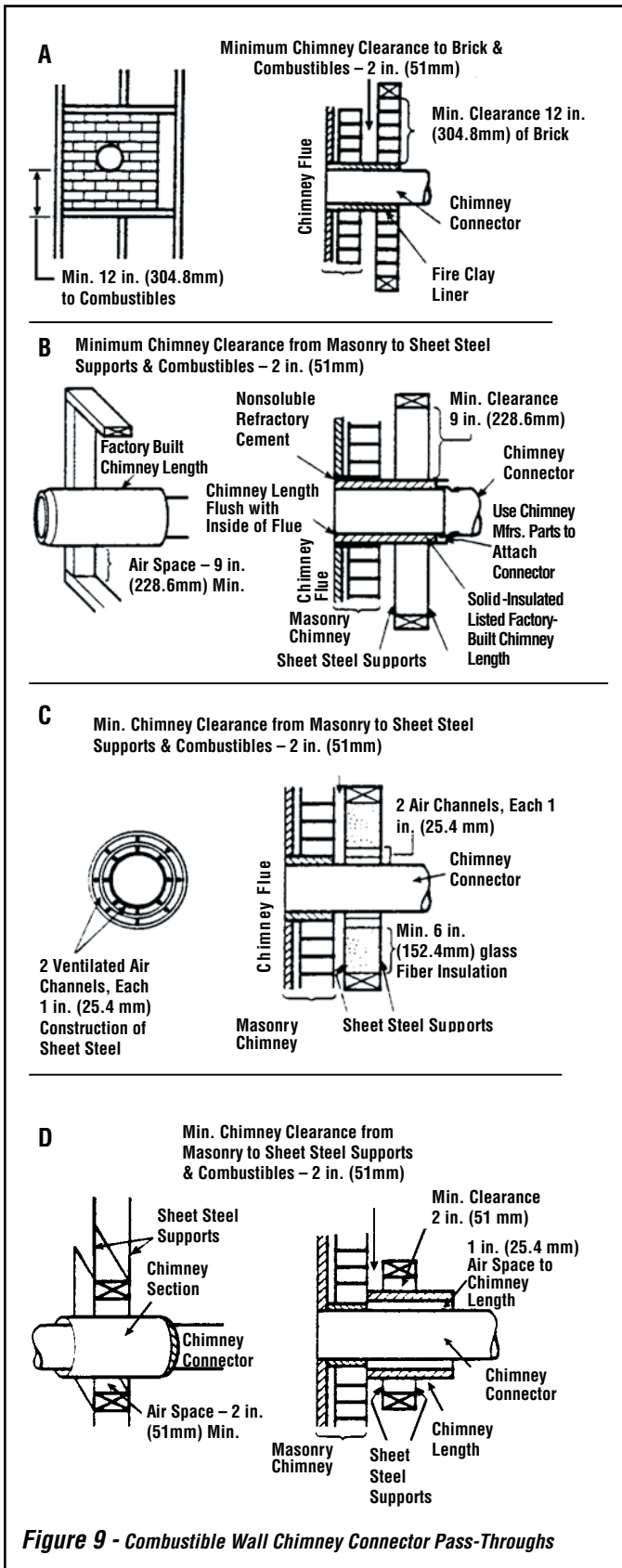
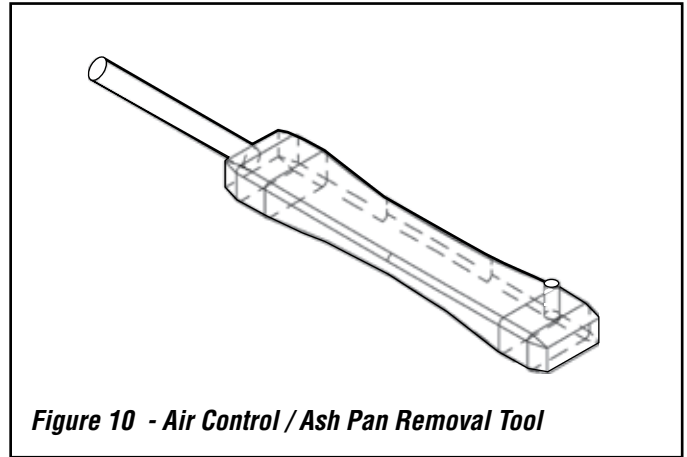

**Figure 9 - Combustible Wall Chimney Connector Pass-Throughs**

**CARE AND OPERATION**

**Primary Air Draft Control**

Use the air control adjustment tool (provided - see *Figure 10*) to adjust the air controls per the following instructions.

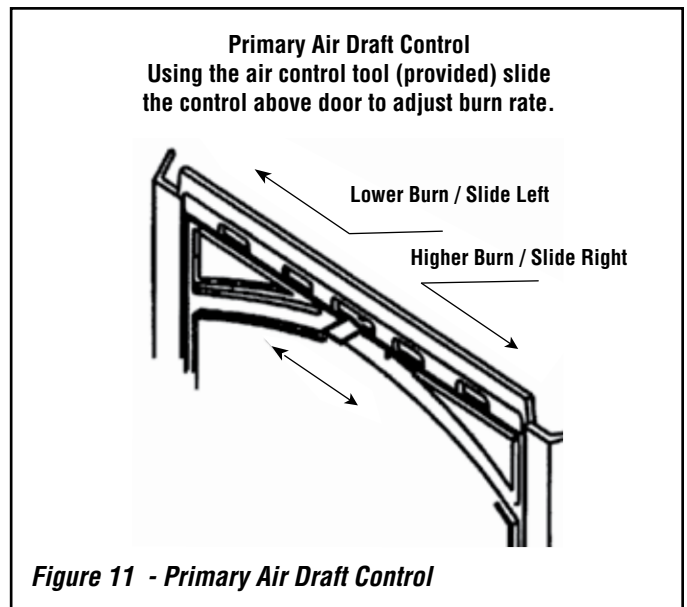

**Figure 10 - Air Control / Ash Pan Removal Tool**

The primary combustion air delivery is controlled by the Primary Air Draft Control Assembly (located above the front door). The heat output can be controlled by sliding the control to a higher or lower heat output setting using the Air Control Tool Provided (See *Primary Air Draft Control* below).

The fuel, the amount of heat and burn times desired, the type of installation are all variables that will affect the control setting. The same control settings in a variety of installations will produce different results. You will need to try different settings so you can learn how much heat to expect and how long the fire will burn.

With the air control tool (provided in accessory package) the control can be adjusted to the heat output desired (see *Figure 11*).



**Figure 11 - Primary Air Draft Control**

## Adjusting Burn Rate:

The primary air draft control located above the front door can be adjusted to the right for higher temperatures and to the left for lower temperatures.

Generally, you will want to set the draft control somewhere in the low or medium range

**Tips** - Adjust the primary air control to a medium to low setting for a slow and more efficient burn. When burning on a higher setting, it is more efficient to burn with a bright but not roaring fire.

## Start Up Air Control (Ignition Booster)

To facilitate lighting, your stove is equipped with an ignition booster, which brings start-up air to the fire for a short period of time. This can be especially helpful when your chimney is cold. The ignition booster can also be used to allow the fire to recover quickly following refuelling.

### **! IMPORTANT**

**The Start-Up Air Control provides supplemental primary air. Do NOT leave the start-up air control in the open position for more than five minutes (this could result in dangerous overfiring which is not covered under the warranty). Close by pushing the lever inwards.**

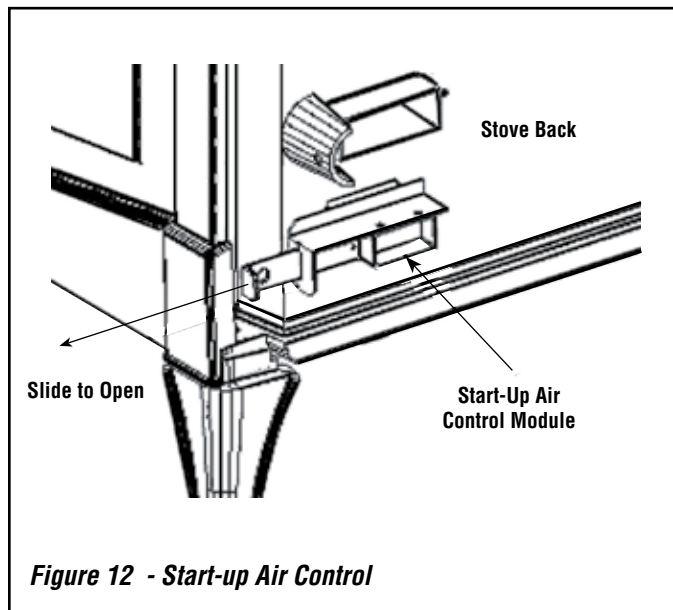

**Figure 12 - Start-up Air Control**

## Before Initial Lighting

1. Using the air control tool open the start-up air control by pulling the lever outwards (see **Figure 12**).
2. Load fuel into the firebox and light the fire as usual (see *How To Start And Maintain A Fire* on **Page 15**).

## How To Start And Maintain A Fire

1. Using the Air Control Tool (provided), open the Start-Up Air Control (see *Start-Up Air Control*, on this Page).
2. Adjust the primary air draft control to the full open position (see *Primary Air Draft Control* on **Page 14**).
3. Open the side fuel loading door and build your fire directly on the grate in the firebox.
  - a. Place five or six loosely crumpled sheets of newspaper in the stove.
  - b. Add a small amount of dry kindling randomly on the top of the newspaper.
  - c. Place a few more loosely crumpled newspapers on top of the kindling and light the bottom paper first, then light the top paper. Once the fire is well underway, close the door. The upper fire should preheat the chimney and create an effective draft while the lower fire ignites the kindling.
4. After the kindling is burning well, add increasingly larger pieces of wood until the fire is actively burning (see bullets below). Leave the fuel door open (slightly ajar for 5 minutes). Then close the stove door. Never leave the stove unattended when the door is open.
  - When loading fuel, be careful not to smother the fire.
  - Load logs evenly across the base being cautious not to place wood in front of the rear edge of the log guard.
5. Once a bed of coals has been established, adjust the primary air control to a lower setting **AND CLOSE THE START-UP AIR CONTROL**.

## Air Delivery Systems

**Tip** – Using the air control tool, adjust the primary air draft control to a medium to low setting for a slow and more efficient burn. On higher settings, it is more efficient to burn with a bright but not roaring fire.

## When Refueling

1. Follow the normal procedure for refuelling described on **Page 17**. However, instead of cracking the door open 1/2," open the start-up air control by pulling the lever outwards. This will supply enough primary combustion air to allow the fire to recover.

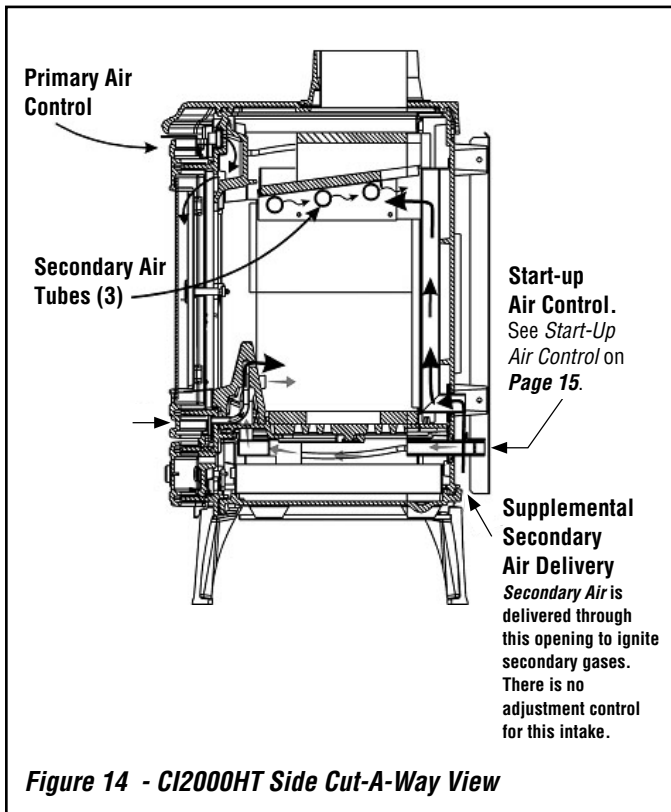
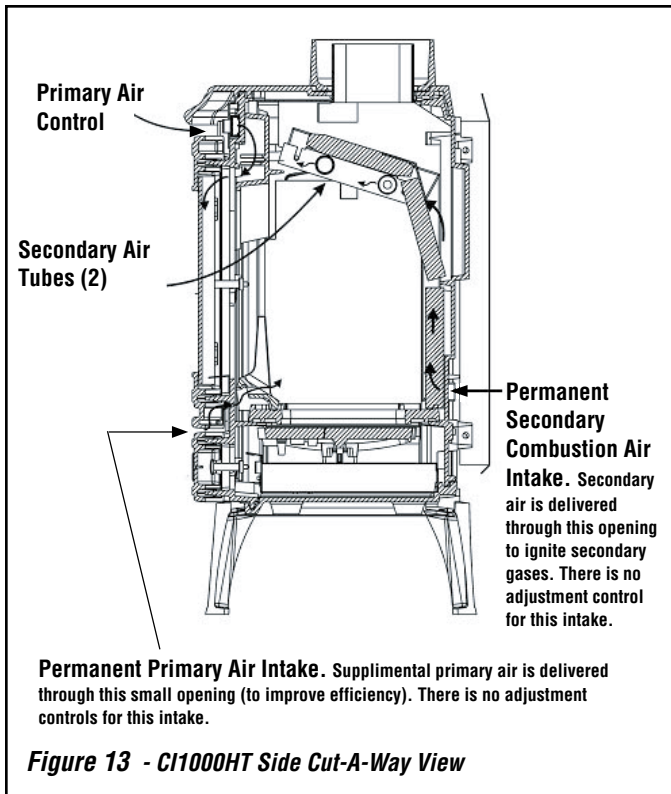

## Front Ash Removal Door And Side Fuel Loading Door

### **CAUTION**

**When opening the doors, do not extend them beyond their normal travel. Overextending the doors to a further open position can put excessive stress on the hinge area of the doors which may result in breakage.**

#### Latch Assemblies

(For front ash removal door, side fuel loading door and ash drawer door).

The door latch assemblies are designed to securely latch the front door, side door and ash drawer door. To open the latches, insert the door handle (provided) into hole in the latch assembly and rotate counterclockwise until door releases. To close and latch, reverse the process

#### Glass

The glass is a 5 mm super heat resistant ceramic that withstands continuous temperatures up to 1256° F. This temperature is well beyond the temperatures in which you operate your stove.

These models are designed to provide a flow of air over the inside of the glass, where along with high heat helps keep it clean. When operating the stove on low for extended periods of time, the glass may get dirty. A short, hot fire (15 - 20 minutes) will help clean off much of the normal buildup (see *Dirty Glass*, **Page 21**). A commercial glass cleaner designed for stoves is recommended for cleaning.

The glass should be cleaned thoroughly with glass cleaner and a soft cloth BEFORE the stove is burned.

#### Use Control Settings That Work For You

### **CAUTION**

**Never leave stove unattended on high settings.**

The fuel, the amount of heat you want, the type of installation you have and how long you wish the fire to burn are all variables that will affect the control setting. The same control settings in a variety of installations will produce different results.

Familiarize yourself with your stove by trying different settings so you can learn how much heat to expect and how long the fire will burn. It may take a week or two to learn but your patience will be rewarded by the warmth and pleasant satisfaction that only a wood fire can provide.

#### Replenish Humidity Level Of Dwelling

Heating the air in a closed building decreases the relative humidity of the air, which will dry wood and other combustible materials. This drying lowers the ignition temperature of these materials, thus increasing the fire hazard. To reduce the risk of fire, some provision should be made for replenishing moisture to the air whenever a structure is being heated for extended periods.



## Burn-In Period

Your stove finish is a high temperature paint that requires time and temperature to completely cure. We recommend that you ventilate the house during the initial burns. The paint emits non-toxic odors during this process.

### **KEEP YOUR HOUSE WELL VENTILATED DURING THE CURING PROCESS TO PREVENT ACTIVATION OF YOUR HOME SMOKE DETECTOR.**

It will take approximately three burn cycles to cure the paint. The first two burns should be low heat, approximately 250°F., for 20 minutes each, using paper and light kindling.

After each 20-minute burn, allow the appliance to cool completely. The third burn should be at least medium high or about 450°F. for 45 - 60 minutes. The paint will become soft and emit non-toxic haze during these burns. Keep the area well ventilated.

As the paint cures it will become slightly lighter in color. Eventually the entire surface will become an even color. Once the paint has been softened and cooled two or three times, it will harden. Do not place anything on the stove surface until the paint is completely cured. Do not attempt to repaint the stove until the paint is completely cured. If the surface later becomes stained or marred, it may be lightly sanded and touched up with spray paint from the same paint (See *Small Area Paint Touch-Up*, **Page 19**). Paint is available at your local authorized Lennox Hearth Products dealer. Never attempt to paint a hot stove.

## First Fire

**Note:** *There is often an unpleasant odor and non-toxic fumes during the first initial burns (this is a natural result of the paint curing). We recommend that a window should be left open near the appliance during this curing process. See Burn-In Period on **Page 17**.*

When your installation has been completed and inspected you are ready to build your first fire.

1. Using the air control tool, open the primary air draft control to the full open position (see *Primary Air Draft Control*, **Page 14**).
2. Open fuel loading door and build a small fire in the stove using tightly rolled paper and dry kindling. Wait a few minutes for a good updraft to establish the fire.
3. Now place two or three thoroughly dried logs on the burning kindling and secure door.
5. After about 25-30 minutes of burning (when fire is well established), slide the primary air draft control to a medium setting. This will keep the fire burning at a moderate level so heat is transferred through the stove rather than up the chimney.
6. Once a bed of coals has been established, adjust the primary air draft control to a low setting.
7. During the first few fires, keep the combustion rate at a low to moderate level. Avoid burning fires with the primary air control wide open for long periods of time. This results in an updraft fire with most of the heat escaping up the chimney.

## **WARNING**

**Read and use the information provided in this section. To disregard this may cause serious permanent damage to the stove and void your warranty. It is best to warm your stove up slowly and keep it at a moderate level.**

## Refueling

### **CAUTION**

**Always check for high flames when opening a door by partially opening door for a few seconds before opening fully.**

To prevent smoke blowing into the room follow these recommendations:

1. Using the air control tool adjust the primary air draft control and start-up air control to the full open position and let the fire "liven up" for about one minute before opening the fuel loading door. Open door about 1/2" and hold in this position about 30 seconds or until stove is drafting well, then fully open the door.
2. Rake the embers towards the front of the stove and spread evenly. If there are logs only partially burned rake these to the front of stove.
  - Feed the logs to the embers. When loading wood, add one or two logs at a time, depending on size. Try and use the side fuel loading door as it will allow for cleaner operation. Load logs evenly across the base being cautious not to place wood in front of the rear edge of the log guard.
  - Close the fuel loading door.
  - With the primary air draft control in the full open position. Crack the door open about 1/2" and let it burn for approximately 5 minutes. Then close the door and adjust the primary air draft control to the desired setting and CLOSE THE START-UP AIR CONTROL.
  - In order to maintain an attractively burning fire, logs should be up to 18" (457 mm) long and well seasoned. Loading the appliance full of damp wood on a low fire is certain to cause low combustion efficiency resulting in tar and dirty glass.
  - High combustion temperatures are the secret to clean glass operation.

## Overnight Burning

To inhibit excessive build-up on the glass during a slow overnight burn, it is recommended that the primary air draft control be adjusted to at least a slightly open position (the optimum setting will depend on how well your chimney draws). To achieve a slow burn (the maximum burn time is 8 hours under optimum conditions - dry, high BTU wood such as oak and proper draft from the chimney).

**Note:** *With a good drafting chimney, the primary air control will need to be closed further than with a poor drafting chimney.*

## FUEL

### Burn Recommended Fuel

This appliance is designed for use with natural well-seasoned wood. Do NOT burn particleboard scraps or pressed logs because they can produce conditions which will deteriorate metal. Green or uncured wood does not work well as fuel, and can cause increased creosote buildups. The value of green wood as a source of heat is limited. Do not overload or use kindling wood or mill ends as primary fuel as this may cause overfiring. Overfiring is a condition where excessive temperatures are reached, beyond the design capabilities of the stove. The damage that occurs from overfiring is not covered under the stove warranty.

### What is the best wood for the fire?

Some woods are easier to light than others (i.e. hornbeam, beech, & oak do not light easily whereas aspen, birch and lime light easily but they do not last as long). Then come the softwoods and conifers. Regardless if you are burning a softer or harder wood, what is most important is that it is well-seasoned dry wood. Damp wood has far less heating power, this lowers the combustion temperature of the fire therefore, the output. Green wood is difficult to light, it burns badly and gives off smoke and causes the formation of deposits (tarring and soot staining) in the chimney flue and on the door glass.

### What is tarring and soot staining in the chimney?

When the smoke arrives in the chimney at low temperature, part of the water vapor which they convey condenses. The heaviest constituents are deposited on the inside of the flue (this is TARRING). The mixture oxidizes in the air and forms brownish patches (this is SOOT STAINING). Four essential points for avoiding these drawbacks, use dry wood, use a stove designed for wood, connect it to a chimney with thick walls and of suitable cross-section (size and height), and ensure the connecting pipes are as short as possible. Horizontal pipes should be no more than 6" (150 mm).

### Flue Gas Temperature

It is recommended to thoroughly heat the flue system during start-up, before adjusting the burn rate to a medium or low setting (see *How To Start And Maintain A Fire, Page 15*). To ensure that the flue system is thoroughly heated, adjust the primary air to a medium/high position for approximately 20-25 minutes after the start-up air is closed before adjusting to a lower setting. This helps to establish the draft and it reduces creosote deposits on the internal surfaces of the stove, glass and chimney.

### Hints:

- Creosote condenses in a cold chimney, not a warm one. Avoid a smoldering fire for more than a twelve-hour period and your chimney will never get cold.
- Burn a hot fire for a short period once or twice a day (and after reloading), and then adjust the primary air draft module to a medium or low position.
- When loading wood, add one or two logs at a time, depending on size. Loading the appliance full of damp wood on a low fire is certain to cause poor combustion efficiency resulting in creosote and dirty glass.
- If the wood is not quite as dry as it should be, to assist for a short period, smokeless coal can be added with the wood to raise the combustion temperature.
- Have the chimney cleaned and inspected by a professional chimney sweep once a year.



## WARNING

**Burning improper fuel (i.e. Charcoal) can result in carbon monoxide poisoning which may lead to death!**

**Carbon monoxide poisoning – early signs of carbon monoxide poisoning resemble the flu with headaches, dizziness, or nausea. If you have these signs, get fresh air at once! Have the heater inspected by a qualified service technician. Some people are more affected by carbon monoxide than others. These include pregnant women, people with heart or lung disease or anemia, those under the influence of alcohol, and those at high altitudes.**

### Why Season Wood?

The key to the success of a good fire that produces heat from a woodstove is the wood. It needs to be well-seasoned natural wood.

### What does "Well-Seasoned" mean?

When a tree is cut down, the wood is green, full of sap and moisture. This moisture content can exceed 80%, which must be reduced to less than 20%. Wood properly seasoned is then capable of generating the heat the stove was designed to provide.

Green wood does not burn easily. Attempting to burn green wood often results in a lot of smoke and very little fire. Time is the most important factor in seasoning wood. Ideally the moisture content should be reduced to 11-20%, although very few of us will be able to check that figure. There are several steps that should be taken to ensure that you come close to these figures.

### Seasoning Guide

Softwoods – 18 months

Hardwoods – 18 months to 24 months

This period can be shortened (12 to 15 months) if the wood is cut to the right length and immediately stored under a ventilated shelter.

Logs that are 5" diameter across or larger should be split in half, three pieces if over 8 inches, and four pieces when over a foot across (split wood dries quicker than round logs). Round logs left in the open for more than a year end up rotten. If the tree was fell 2 to 4 years ago, it still needs to be cut, split, and seasoned for 18 to 24 months depending on the wood.

Wood which is too small to split must be drained, by removing some of the bark.

### Wood Storage

Wood to be seasoned should be stacked in an area open enough to ensure good air circulation on both sides – leaving adequate space between woodpiles to walk comfortable. Do not stack wood against a wall or building. It helps to elevate the wood piles off the ground (two 2 x 4's running lengthwise beneath the woodpile works well). This allows air to flow under the bottom logs.

Store wood in a cool, dry place, well away from any source of flame or heat. Keep paper, wood, rags and other easily ignited materials away from the wood. If wood should become wet, separate it and allow it to dry naturally; do not mix wet and dry wood or pile wet wood on top of dry wood. If wood is kept outdoors, either covered with a tarp, or not covered at all, it will not burn well until it has been in an enclosed space for one to two months. If stored outside, keep the wood covered to protect from rain or snow.

Wood supplied in ready-cut lengths stored immediately under a ventilated shelter dries quicker than wood stocked in high piles.

## MAINTENANCE



### WARNING

**Do NOT clean the stove while it is hot!**



### IMPORTANT

**Inspect the entire stove frequently for proper operation, fit and soundness of parts. If any malfunctioning, cracked, broken, or loose parts or other problems are noted, contact your dealer or qualified serviceman to inspect and repair the unit. Do not operate the unit if installed or functioning improperly.**

#### Summer Shut Down

Remove ashes and cinders from the stove and dispose of (see *Ash Removal and Disposal* on this page). If the room is damp, place some absorbent crystals inside the stove and/or disconnect it completely from the chimney. Close doors and secure the latches closed.

#### Cleaning Heater Surface

Clean the heater surface with a dry or slightly damp cloth. In case of condensation, clean the affected areas before they dry.

#### Small Area Paint Touch-up

The stove body is painted with a quality high-temperature stove paint. Use only Stove Paint, Catalog #40M6801. Do not touch-up your stove with any other paint.

Using one small piece of 320 grit sand paper and lightly sand the blemish so that the edges are “feathered” or smooth to the touch between the painted and bare surfaces. Do not let the sand paper gum up with paint, as this will cause scratches on the metal surface. If there are any scratches, use 600 grit sandpaper instead. Mask off surfaces you do not want painted. Paint lightly over the bare surface first as this will act as an undercoat. Then paint over a larger area in smooth even strokes to blend.

See *Burn-In Period* on **Page 17** for information on curing the paint.

#### Ash Removal And Disposal

Empty the ash pan regularly to prevent the ash from spilling over. Do not allow the ash to build up and touch the under side of the grate.

To remove the ash from the stove, operate the firebox grate using the handle.

A layer of ash left over the grate when burning wood will protect the grate and retain heat so encouraging clean combustion.

The tool provided for removal of the ash pan should not be used to carry the ash pan. Use a leather glove and hold the ash pan on both sides.

Ashes can hold live embers for several days, and must be disposed of with care.



### WARNING

**Make sure that the fire is out and the stove is cold before removing ashes!**

**NEVER PLACE ASHES IN A CARDBOARD BOX OR ANY OTHER COMBUSTIBLE RECEPTACLE.**

#### Proper Disposal of Ashes:

Ashes should be placed in a metal container with a tight fitting lid. The closed container of ashes should be placed on a noncombustible floor or on the ground, well away from all combustible materials, pending final disposal.

If the ashes are disposed of by burial in soil or otherwise locally dispersed, they should be retained in the closed container until all cinders have thoroughly cooled.

#### Door, and glass gaskets

If the gaskets which provide a seal around the doors or glass should become frayed or damaged they should be replaced with the same size and type as the original gasket. Contact your dealer for ordering. Use high temperature silicone sealer as an adhesive for the door gasket. The glass gasket has a self-adhesive backing (see *Replacement Parts* on **Pages 24 through 30**). If the gasketing is in good condition, check the closure latch screws; if these are loose, tighten with a phillips screwdriver (do not overtighten).



### WARNING

**The gaskets must be kept in good condition. Do not leave the stove burning with the fuel loading doors open or ajar. This will cause excessive heat build up in the unit and could ignite surrounding combustibles as well as damage the stove by overfiring it. Overfiring is a condition where excessive temperatures are reached, beyond the design capabilities of the stove (such damage is not covered by the manufacturers warranty).**

#### Firebrick

The firebrick should be inspected periodically and replaced if damaged (crumbling or excessively cracked). Through normal wear and tear, the firebrick may need to be replaced over time (through proper installation, operation, maintenance and fuel, the longevity of the firebrick will be increased – see *Overfiring Damage, Page 21*). For information on warranty of the firebrick, see warranty statement provided with the appliance.



### CAUTION

**Be careful not to abuse door assembly by striking or slamming it. If the door assembly or glass is broken or damaged, they must be replaced with factory original parts before heater can be safely operated. Use only components provided by the manufacturer as replacement parts.**

#### Cleaning Glass

Ensure stove is cold prior to cleaning glass. A commercial glass cleaner designed for stoves is recommended. Do not use abrasive cleaners. Do not clean with any materials, which may scratch or otherwise damage the glass. Scratches on the glass can develop into cracks or break. Inspect the glass regularly. If you detect a crack, extinguish the fire and contact your dealer for a replacement.

## Replacing Glass:

1. Open the door. Using a phillips screwdriver loosen the four (4) screws which secure the glass then carefully remove broken glass one piece at a time (protective leather gloves are recommended).
2. Remove screws and clips from doorframe and set aside.

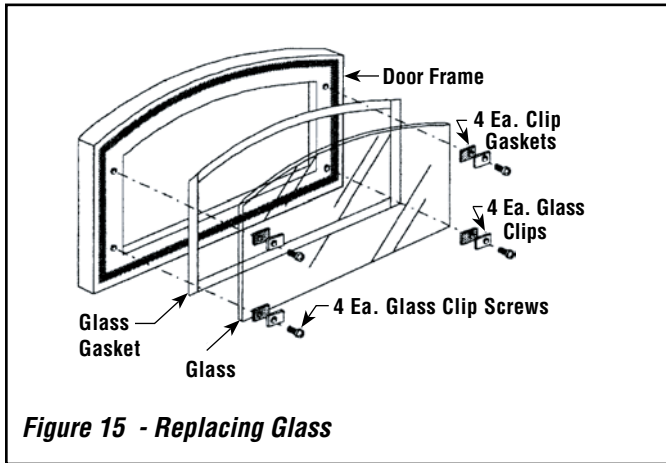

3. Clean the area where the glass with gasket will be installed.
4. Install new glass with gasket (use only factory 4-mm glass with glass channel gasket. Do not substitute).
5. Carefully reinstall glass clips with gasket and screws. Be very careful not to overtighten the screws (this could result in breakage when stove is hot).

## Creosote Formation And Need For Removal

**What is Creosote** - When wood is burned slowly, it produces tar and other organic vapors, which combine with expelled moisture to form creosote. The creosote vapors condense in the relatively cool chimney flue of a slow-burning fire. As a result, creosote residue accumulates on the flue lining. When ignited this creosote makes an extremely hot fire. Also, creosote deposits tend to form in long runs of venting where gases become too cool prior to exhausting. Note: Single wall pipe cools rapidly, therefore installations using this type of flue are more susceptible to creosote deposits.

To inhibit the build up of creosote, adjust the primary air draft control to a medium-high or high setting for a 10-minute period each day. Do not attempt to burn out heavy creosote accumulations in this manner. This must be removed from the chimney by scraping or brushing to reduce the risk of a chimney fire.

**Burn Approved Fuel Only** - This stove is approved for burning dry seasoned natural wood only. Using green or inadequately seasoned wood may increase creosote buildup.

**Inspection Frequency** - The chimney connector and chimney should be inspected at least twice monthly during the heating season to determine if a creosote buildup has occurred. If creosote has accumulated it should be removed to reduce the risk of a chimney fire. If creosote has accumulated (1/8" [3 mm] or more) it should be removed to reduce the risk of a chimney fire. Experienced chimney servicing personnel should be consulted.

Cleaning - Remove the baffle brick in the firebox prior to having your chimney cleaned (should be done by a qualified chimney sweep). See following - *Removing Baffle Brick for Cleaning*.

## Removing Baffle for Cleaning

Before flue can be cleaned, the baffle in the stove firebox must be removed. The CI1000HT has one vermiculite firebrick, which serves as a baffle for the flue gasses. The CI2000HT has a 5-sided box made of ceramic fiber brick that serves as a baffle. In both cases, the baffles are located just above the secondary air tubes (which must be removed to access the baffle). *Suggestion: Wear a pair of leather work gloves when removing secondary air tube assembly and baffle.*

1. To access the baffle, the secondary air tube assembly must be removed. Locate the four (4) screws, which secure the assembly into place (located at the ceiling of the firebox). Remove the assembly and set aside. Slide the baffle out and set aside.
2. Once the baffle is removed from the firebox, the flue can be cleaned. The accumulated soot that is removed by brushing will fall to the firebox floor where it can be removed and disposed of.

## ⚠ WARNING

**Do NOT operate the stove without the baffle brick properly installed. This will void the warranty and the stove will not function properly.**

## ⚠ IMPORTANT

**IN THE EVENT OF A CHIMNEY FIRE - Make sure the fuel loading doors are securely closed. Adjust the primary air draft control to the lowest (most closed) setting and ensure that the start-up air control is closed. Call the fire department immediately. After a chimney fire, the complete chimney system should be checked by a qualified technician before further use.**

**Consult your dealer for suggestions on proper chimney care. Contact your local municipal or provincial fire authority for information on how to handle a chimney fire. Have a clearly understood plan for handling a chimney fire. Establish a routine for the fuel, stove and firing technique. Check daily for creosote build-up until experience shows how often you need to clean to be safe. Be aware that the hotter the fire the less creosote is deposited, and weekly cleaning may be necessary in mild weather even though monthly cleaning may be enough in the coldest months.**

## Reinstall Baffle Brick

After your chimney has been swept, reinstall the baffle brick (see *Removing Baffle for Cleaning* and reverse steps).

## TROUBLESHOOTING

### \* When Fuel Door Is Opened, Smoke Enters Room

1. The primary air draft control is closed.
2. The chimney is too cool. Set the primary air draft control on "HIGH" for a few minutes before opening either fuel loading door.
3. Excess creosote will not only restrict your draft but it will create a risk of a creosote fire. Strictly adhere to maintenance requirements as outlined in this manual. If excess creosote has built up on the inside of the firebox sides and door, burn a small hot fire at intervals that are more frequent with air control on HIGH for a few minutes.
4. Deposits may have built up in the chimney and are restricting the draft, or the spark arrester on top of the chimney may be plugged.
5. Chimney diameter too large or too small to provide adequate draft.
6. The house is too airtight (usually takes 20 to 30 minutes for problem to appear as stove lowers air pressure in house). Crack a window open or provide an outside source of air near stove.
7. Insufficient vertical height to chimney to achieve adequate draft.

### Does Not Produce Enough Heat

1. Using green or insufficiently cured wood.
2. Excessive draft.
3. High ceilings (heat rises quickly, but can be recirculated by a well-placed ceiling fan with a winter/summer switch).
4. The area to heat is too large (square foot heating estimates are based on "average" climates and home design).
5. There is an obstruction in the chimney.
6. The chimney or chimney cap is restricted by creosote preventing enough draw to sustain a "high" heat output rate.

### \* Does Not Maintain A Fire

1. Soft wood does not burn as long or as well as seasoned hardwood resulting in a short burn time.
2. Wood size too small. Burns at too rapid a rate.
3. The gasket seal on the fuel loading doors, or glass is leaking air. Repair or replace it if necessary.
4. Excessive draft.
5. There may be an obstruction in the chimney.

### \* Backpuffing

**Definition:** *This is a term describing the condition when combustible gases remain unlit because of insufficient combustion air delivery which results in combustible gases building, then flash igniting. If backpuffing is occurring, it can push some smoke into the room through the primary or secondary air openings. The combustion air delivery is dependent upon the draft of the venting system. The following are variables, which can negatively affect the draft resulting in backpuffing.*

1. Downdraft in the chimney (a special wind cap may be needed).
2. The house is too air tight (ventilation is needed).
3. Insufficient vertical height to chimney to achieve adequate draft.

### Odors

1. Creosote accumulation in firebox (brush out on next cleaning).
2. Chimney downdraft when stove is not operating (close the primary air draft control).
3. Paint curing on first several burns.

### \* Dirty Glass

1. Poor draft conditions.
2. Long burn periods at low draft settings.
3. Burning wet, pitchy or spongy wood.
4. Poorly arranged logs (too close to glass).

**\* Draft problems; if installing into a larger flue, it may be necessary to use a full-length liner to achieve adequate draft for the appliance. A draft gauge should read a minimum of .05" W.C. (inches water column) not to exceed .06" W.C. for optimum performance (See Draft Requirements on Page 11).**

## OVERFIRING DAMAGE

If the heater or chimney connector glows, you are overfiring. Other symptoms may include: Cracking, warping or burning out of components, stove glass may develop a haze, which will not come off with cleaning.

Overfiring of a stove is a condition where excessive temperatures are reached, beyond the design capabilities of the appliance. The damage that occurs from overfiring is not covered under the manufacturers limited warranty.

The following are a few conditions that should be evaluated and (corrected if necessary) if an overfiring condition is suspected:

### Overfiring Caused From Improper Installation

Ensure that all installation requirements have been met as outlined in the installation manual. The chimney should be clean and in good repair. A draft test should be performed to determine if the draft requirements of the appliance are being met. A draft gauge should read between .05 and .06 " W.C. (inches water column). Excessive draft (above .06 " W.C.) will allow too much combustion air to be pulled in which results in hotter burns. Too little draft (below .05 " W.C.) will not allow enough combustion air delivery to maintain a fire (this may result in improper operation of appliance, i.e. wont maintain fire unless fuel loading door is left open. See following, *Overfiring Caused From Improper Operation*).

### Overfiring Caused From Improper Operation

Operate this appliance only as outlined in this manual. Never burn the appliance with either fuel loading door open or ajar. Do not operate this stove with the *Primary Air Draft Control* in the full "open" position for extended periods. This wastes fuel and can cause dangerous overfiring conditions. NEVER leave the stove unattended on high settings.

### Overfiring Caused From Improper Maintenance

Strictly adhere to all maintenance requirements at frequent intervals as prescribed in this manual including cleaning of flue and stove. Should either fuel loading door or glass gaskets become worn or damaged, they should be replaced.

### Overfiring Caused From Improper Fuel

This appliance is approved for use with natural dry well-seasoned wood only (ask your authorized dealer what are approved fuels for your area). Do not burn garbage, particleboard scraps, or pressed logs because they can produce conditions that will deteriorate metal. Do not overload or use kindling wood or mill ends as primary fuel as this may cause overfiring.

**SPECIFICATIONS - Model CI1000HT**

<b>Flue position</b>	<b>Top</b>
<b>Flue collar size</b>	<b>6" (152 mm)</b>
<b>Approx. burn time</b>	<b>6 to 8 hours</b>
<b>Maximum burn rate</b>	<b>87,301 BTU</b>
<b>EPA BTU Range</b>	<b>11,500 – 55,000 BTU</b>
<b>Emissions Rate (grams/hr)</b>	<b>4.42 grams</b>
<b>Maximum Log length</b>	<b>18" (457 mm)</b>
<b>Firebox Size</b>	<b>1.12 cu. feet</b>
<b>Loading</b>	<b>Front &amp; Side</b>
<b>Width (overall)</b>	<b>23-3/4" (604 mm)</b>
<b>Depth (overall)</b>	<b>15-5/16" (389 mm)</b>
<b>Height (to flue)</b>	<b>30" (762 mm)</b>
<b>Height (to stove top)</b>	<b>27-1/4" (693 mm)</b>
<b>Back to centerline of flue</b>	<b>6-7/16" (163 mm)</b>
<b>Approx. weight with brick</b>	<b>~280 lbs. (140 kg)</b>

*Note: Dimensions shown are approximate only (+/- 1/4").*

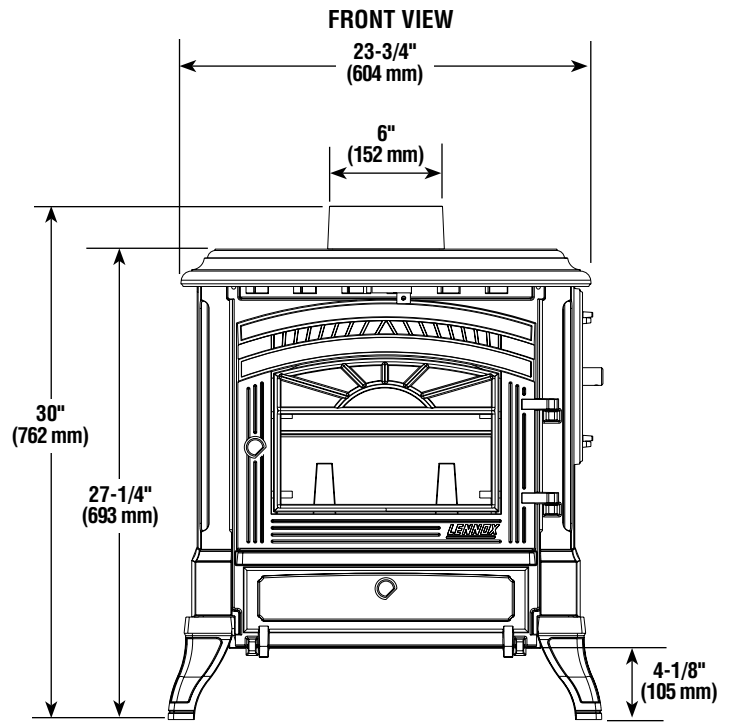
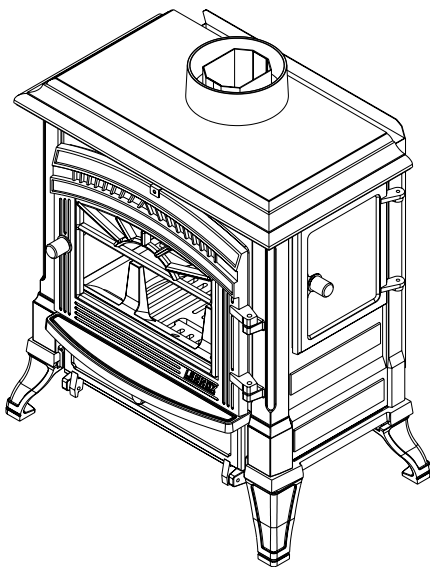

*\* Shown with optional window trim*

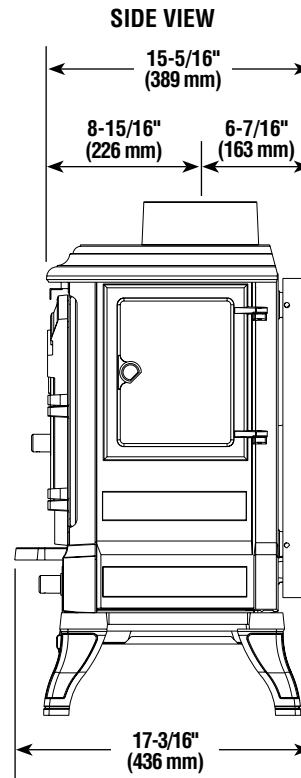

**SPECIFICATIONS - Model CI2000HT**

<b>Flue position</b>	<b>Top</b>
<b>Flue collar size</b>	<b>6" (152 mm)</b>
<b>Approx. burn time</b>	<b>6 to 8 hours</b>
<b>Maximum burn rate</b>	<b>96,662 BTU</b>
<b>EPA BTU Range</b>	<b>11,923 – 60,897 BTU</b>
<b>Emissions Rate (grams/hr)</b>	<b>2.72 grams</b>
<b>Maximum Log length</b>	<b>22" (559 mm)</b>
<b>Firebox Size</b>	<b>1.97 cu. feet</b>
<b>Loading</b>	<b>Front &amp; Side</b>
<b>Width (overall)</b>	<b>29-1/8" (740 mm)</b>
<b>Depth (overall)</b>	<b>18-3/4" (476 mm)</b>
<b>Height (to flue)</b>	<b>32-13/16" (833 mm)</b>
<b>Height (to stove top)</b>	<b>29-3/4" (756 mm)</b>
<b>Back to centerline of flue</b>	<b>7-11/16" (195 mm)</b>
<b>Approx. weight with brick</b>	<b>~410 lbs. (205 kg)</b>

*Note: Dimensions shown are approximate only (+/- 1/4").*

**FRONT VIEW**

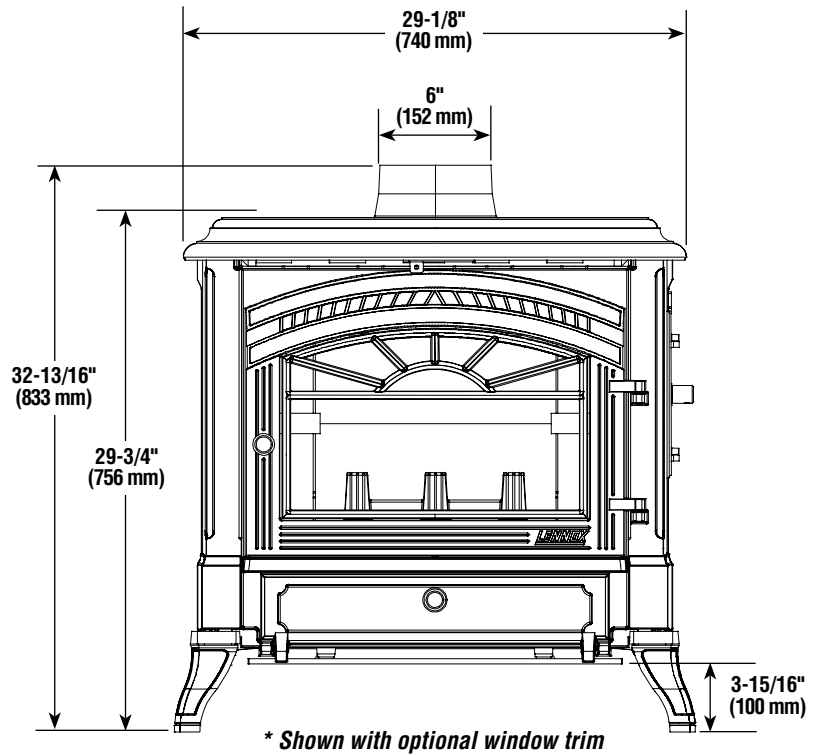

**SIDE VIEW**

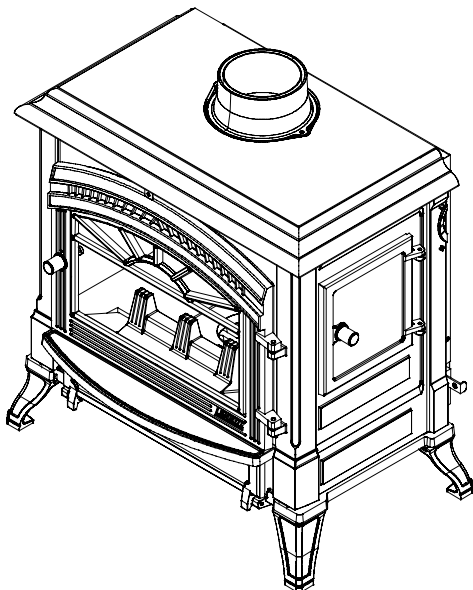
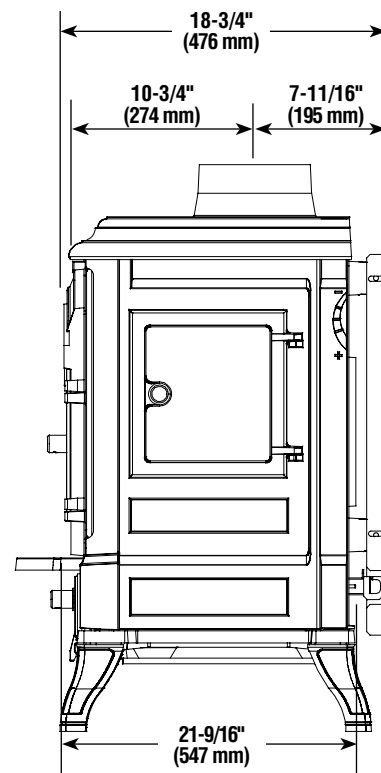

**REPLACEMENT PARTS LIST - Models: CI1000HT & CI2000HT**

Item	Cat. No.	Description	Where Used
31	40M5701	Air Column Set, Left & Right (Includes Gaskets & Screws)	CI1000HT
32	40M6901	Air Column Set, Left & Right (Includes Gaskets & Screws)	CI2000HT
33	40M2301	Air Deflector (Air Wash), Upper (Includes Hardware)	CI1000HT
34	40M9801	Air Deflector (Air Wash), Upper (Includes Hardware)	CI2000HT
35	40M2101	Ashlip, Charcoal, Painted (Includes Gasket & Screws)	CI1000HT
35	40M8601	Ashlip, Charcoal, Painted (Includes Screws)	CI2000HT
36	40M3901	Ashpan Assembly	CI1000HT
36	41M0501	Ashpan Assembly	CI2000HT
	40M3601	Back, Steel Stove (Includes Hardware)	CI1000HT
	41M0301	Back, Steel Stove (Includes Hardware)	CI2000HT
37	40M5101	Baffle Assembly, ceramic fiber brick (Baffle Box)	CI2000HT
38	41M0401	Channel Assembly, Start-Up Air (Includes Gasket And Hardware)	CI2000HT
	41M0101	Clip Set, Glass (Includes 4 Ea. Gaskets, Screws & Clips)	CI1000HT & CI2000HT
39	40M2701	Collar Kit, Charcoal Replacement Flue (Includes Gasket & Hardware)	CI1000HT
40	40M9001	Collar Kit, Charcoal Replacement Flue (Includes Gasket & Hardware)	CI2000HT
3	40M0701	Door, Ashpan, Charcoal (Handle Receiver Not Included)	CI1000HT
4	40M4301	Door, Ashpan, Charcoal (Handle Receiver Not Included)	CI2000HT
1	40M1701	Door, Firebox, Charcoal (Handle Receiver Not Included)	CI1000HT
1	40M8201	Door, Firebox, Charcoal (Handle Receiver Not Included)	CI2000HT
2	40M1201	Door, Side Loading, Charcoal (Handle Receiver Not Included)	CI1000HT
2	40M7801	Door, Side Loading, Charcoal (Handle Receiver Not Included)	CI2000HT
47	40M3501	Draft Module, Air Intake (Slide Assembly) Includes Gasket & Hardware	CI1000HT
48	41M0201	Draft Module, Air Intake (Slide Assembly) Includes Gasket & Hardware	CI2000HT
12	41M3901	Firebrick, Left	CI1000HT
13	41M3801	Firebrick, Lower Rear	CI1000HT
14	41M4001	Firebrick, Right	CI1000HT
15	41M3701	Firebrick, Baffle (vermiculite)	CI1000HT
16	41M4101	Firebrick, Upper Rear	CI1000HT
5	41M5501	Firebrick, Bottom Center	CI2000HT
6	41M4901	Firebrick, Bottom Side (left or right)	CI2000HT
7	41M5001	Firebrick, Left Lower	CI2000HT
8	41M5101	Firebrick, Left Upper	CI2000HT
9	41M5401	Firebrick, Lower Rear	CI2000HT
10	41M5201	Firebrick, Right Lower	CI2000HT
11	41M5301	Firebrick, Upper Rear	CI2000HT
17	40M7201	Frame, Fuel Grate (bottom)	CI1000HT
18	40M9301	Frame, Fuel Grate (bottom)	CI2000HT

**Note:** The item numbers correspond to component diagrams on **Pages 26 through 30**



**REPLACEMENT PARTS LIST - Models: CI1000HT & CI2000HT**

Item	Cat. No.	Description	Where Used
	40M4501	Gasket Kit, 6 mm x 156 cm (14979) For Air Intake Slide & Glass & 4 ea. 6mm Glass Clip Gaskets (31856)	CI1000HT & CI2000HT
	40M0201	Gasket Kit, Ashpan Door Rope (8 mm Dia. X 97 cm)	CI1000HT
	40M4201	Gasket Kit, Rope (10 mm Dia. x 146cm) Ashpan Door - CI2000HT, Side & Front Firebox Door - CI1000HT	CI1000HT & CI2000HT
	40M4401	Gasket Kit, Rope (12 mm Dia. x 177 Cm) Front & Side Door CI2000HT	CI2000HT
19	40M4901	Gasket Set, Air Column, 70mm X 45mm (Also Includes Start Up Air Channel - Model CI2000HT Only)	CI1000HT & CI2000HT
	41M3601	Gasket, Flue Outlet	CI1000HT
	40M5401	Glass, Replacement, 10.39" X 14.02" (Includes Gasket)	CI1000HT
	41M0801	Glass, Replacement, 18.82" X 12.52" (Includes Gasket)	CI2000HT
20	40M4001	Grate Support Bar, Fuel	CI1000HT
21	40M1301	Grate, Ash Removal	CI1000HT
22	40M2901	Grate, Fuel	CI1000HT
23	40M9601	Grate, Fuel	CI2000HT
24	40M5301	Hinge Pin Set, Ashpan Door (Includes 2 Hinge Pins, 2 Acorn Nuts & 2 Washers)	CI1000HT & CI2000HT
25	40M4101	Hinge Pin Set, Firebox Door (Includes 2 Hinge Pins, 2 Acorn Nuts & 4 Washers)	CI1000HT
26	40M5601	Hinge Pin Set, Firebox Door (Includes 2 Hinge Pins, 2 Acorn Nuts & 4 Washers)	CI2000HT
27	40M5801	Hinge Pin Set, Side Door (Includes Hinge Pins, 2 Acorn Nuts & 2 Washers)	CI1000HT & CI2000HT
28	41M0901	Leg, Front Left, Charcoal (Includes Gasket & Hardware)	CI1000HT & CI2000HT
28	40M9501	Leg, Front Right, Charcoal (Includes Gasket & Hardware)	CI1000HT & CI2000HT
28	41M3101	Leg, Right & Left Rear, Charcoal (Includes Gasket & Hardware)	CI1000HT & CI2000HT
29	40M2801	Log Guard (With 2 Andirons)	CI1000HT
30	40M9701	Log Guard (With 3 Andirons)	CI2000HT
	40M68	Paint, Touch-Up Spray, Charcoal, 1 Spray Can	CI1000HT & CI2000HT
41	40M6201	Poker, Fire	CI1000HT & CI2000HT
42	40M5201	Receiver Assembly, Ashpan Door Handle (Includes Latch)	CI1000HT
42	40M0301	Receiver Assembly, Ashpan Door Handle (Includes Latch)	CI2000HT
42	40M1001	Receiver Assembly, Firebox Door Handle (Includes Latch)	CI1000HT & CI2000HT
42	40M3801	Receiver Assembly, Side Door Handle (Includes Latch)	CI2000HT
42	40M6101	Receiver Assembly, Side Door Handle (Includes Latch)	CI1000HT
49	41M5601	Retainer Set, Firebrick (Includes 1 Left, 1 Right & 2 Rear Firebrick Retainers & Hardware)	CI2000HT
	41M4201	Retainer, Firebrick Steel	CI1000HT
43	40M6001	Secondary Air Tube Kit (Includes Screws)	CI1000HT
44	40M0101	Secondary Air Tube Kit (Includes Screws & Washers)	CI2000HT
45	41M1001	Tool, Ashpan Removal / Air Control	CI1000HT & CI2000HT
46	40M5501	Tool, Removable Door Opener	CI1000HT & CI2000HT
	41M0601	Tube, Front Air Feed	CI2000HT

**Note:** The item numbers correspond to component diagrams on **Pages 26 through 30**

**REPLACEMENT PARTS - Models: CI1000HT & CI2000HT**

**(1) Front Firebox Door**  
(CI1000HT & CI2000HT Series)

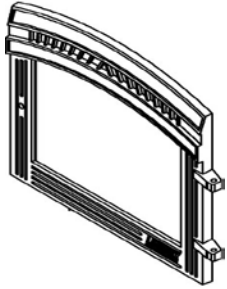

**(2) Side Loading Door**  
(CI1000HT Series)

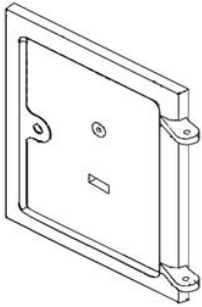

**(2) Side Loading Door**  
(CI2000HT Series)

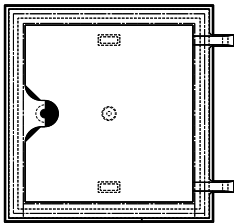

**(↕3) Ashpan Door**  
(CI1000HT Series)

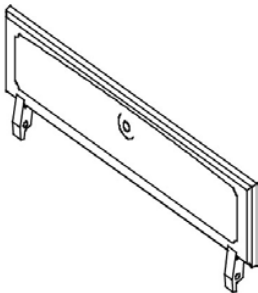

**(4) Ashpan Door**  
(CI2000HT Series)

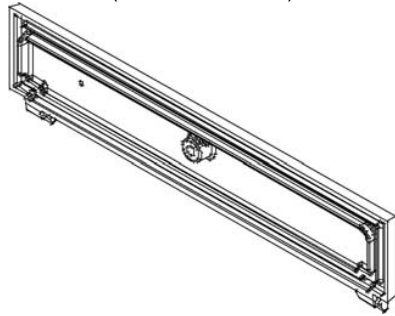

**(5) Bottom Center Firebrick**  
(CI2000HT Series)

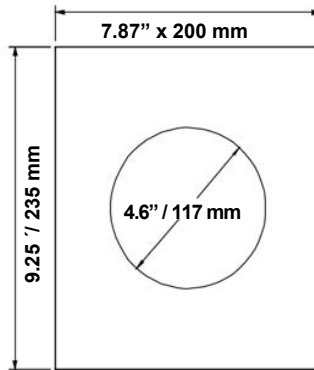

**(6) Bottom Side Firebrick**  
(CI2000HT Series)

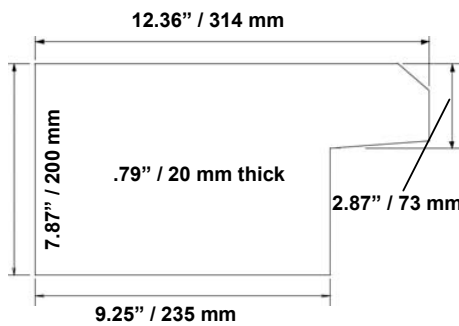

**(7) Left Lower Firebrick**  
(CI2000HT Series)  
7.87\"/>

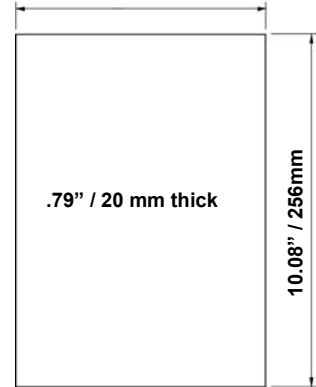

**(8) Upper Left Firebrick**  
(CI2000HT Series)  
10.43\"/>

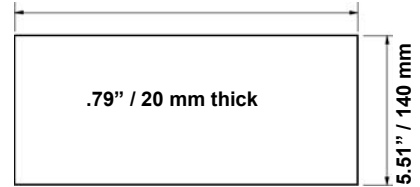

**(↕9) Lower Rear Firebrick**  
(CI2000HT Series)

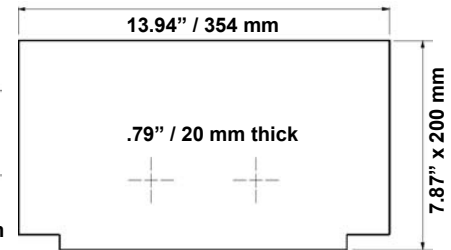

**REPLACEMENT PARTS - Models: CI1000HT & CI2000HT**

**(10) Right Lower Firebrick**  
(CI2000HT Series)

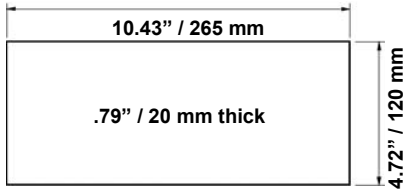

**(11) Upper Rear Firebrick**  
(CI2000HT Series)

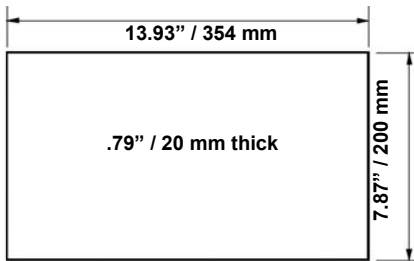

**(12) Left Firebrick**  
(CI1000HT Series)

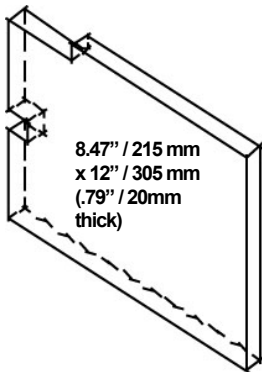

**(13) Lower Rear Firebrick**  
(CI1000HT Series)

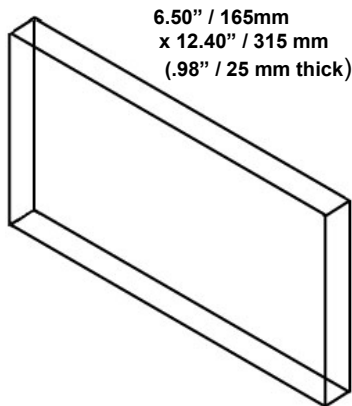

**(14) Right Firebrick**  
(CI1000HT Series)

8.47\"/>

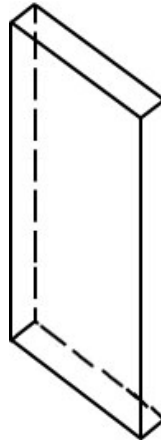

**(15) Baffle Firebrick**  
(above tubes on ceiling)  
(CI1000HT Series)

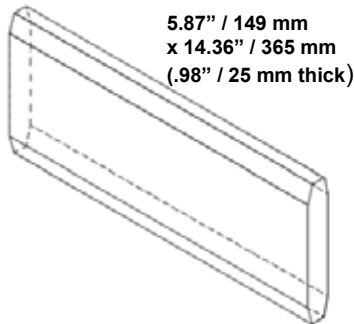

**(16) Upper Rear Firebrick**  
(CI1000HT Series)

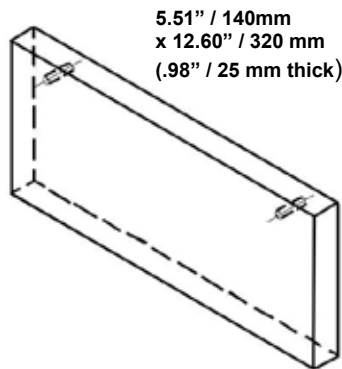

**(17) Fuel Grate Frame**  
(CI1000HT Series)

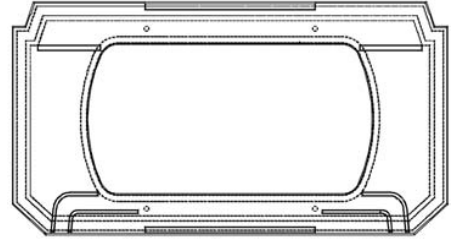

**(18) Fuel Grate Frame**  
(CI2000HT Series)

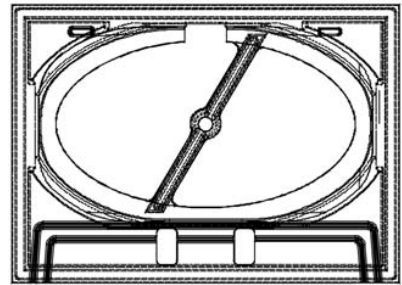

**(19) Air Column Gasket**  
(CI1000HT & CI2000HT Series)

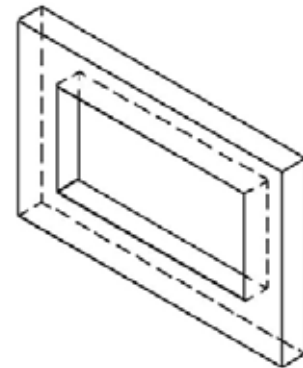

**(19) Start-up Air Column Gasket**  
(CI2000HT Series)

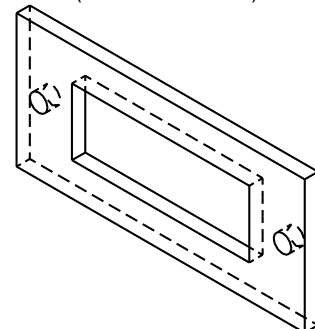

**REPLACEMENT PARTS - Models: CI1000HT & CI2000HT**

**(20) Fuel Grate Support Bar**  
(CI1000HT Series)



**(21) Ash Removal Grate**  
(CI1000HT Series)

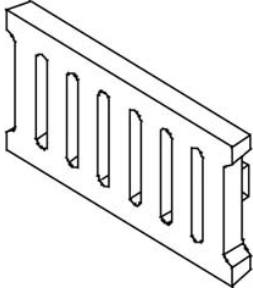

**(22) Fuel Grate**  
(CI1000HT Series)

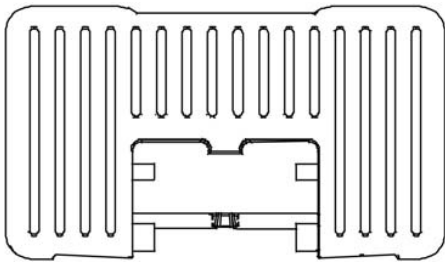

**(23) Fuel Grate**  
(CI2000HT Series)

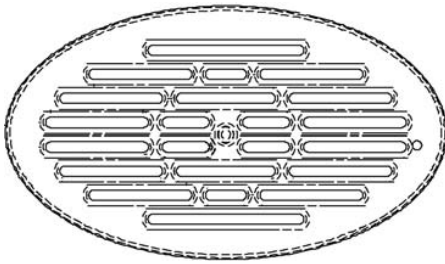

**(24) Ashpan Door Hinge Pin**  
(CI1000HT & CI2000HT Series)



**(25) Front Firebox Door Hinge Pin**  
(CI1000HT Series)



**(26) Front Firebox Door Hinge Pin**  
(CI2000HT Series)



**(27) Side Door Hinge Pin**  
(CI1000HT & CI2000HT Series)



**(28) Stove Leg**  
(CI1000HT & CI2000HT Series)

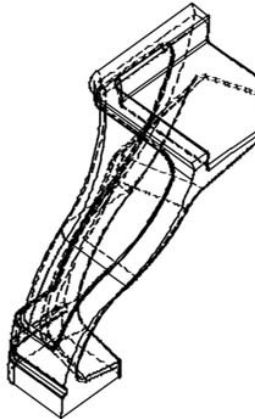

**(29) Log Guard**  
(CI1000HT Series)

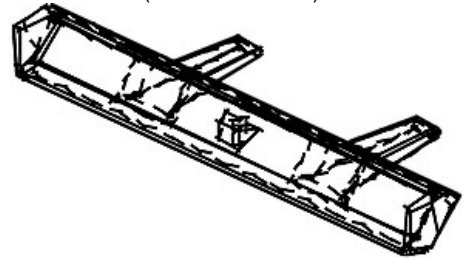

**(30) Log Guard**  
(CI2000HT Series)

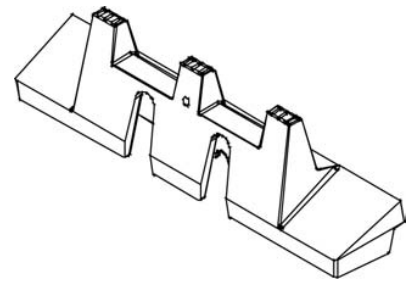

**(31) Left Air Column Assembly**  
(CI1000HT Series)

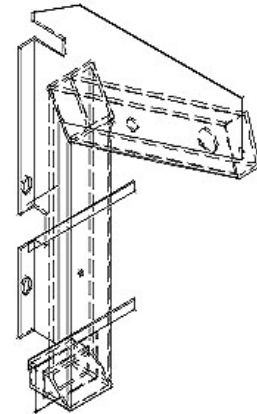

**(31) Right Air Column Assembly**  
(CI1000HT Series)

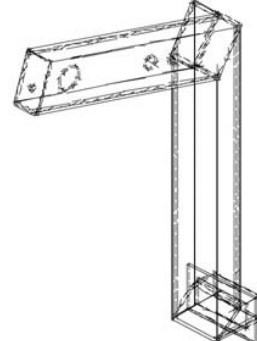

**REPLACEMENT PARTS - Models: CI1000HT & CI2000HT**

**(32) Left Air Column Assembly**  
(CI2000HT Series)

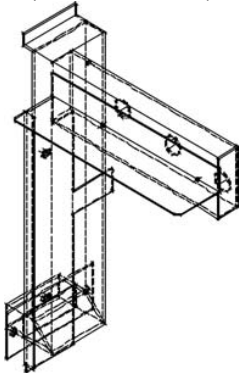

**(32) Right Air Column Assembly**  
(CI2000HT Series)

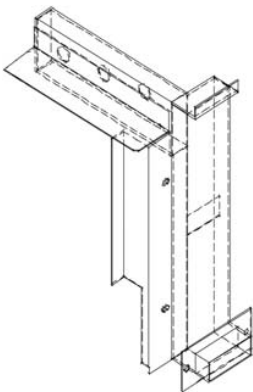

**(33) Upper Air Deflector**  
(CI1000HT Series)

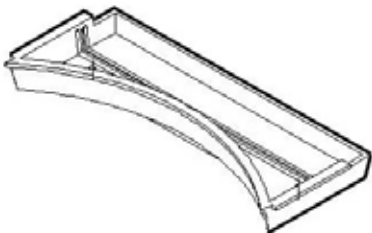

**(34) Upper Air Deflector**  
(CI2000HT Series)

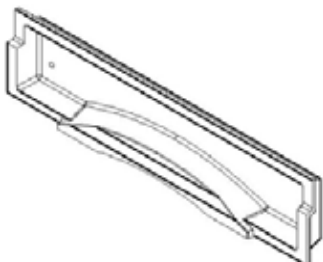

**(35) Ashlip**  
(CI1000HT & CI2000HT Series)

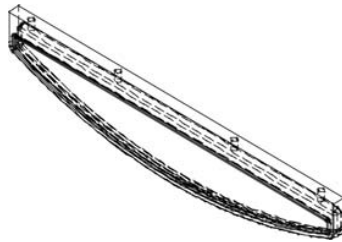

**(36) Ashpan**  
(CI1000HT & CI2000HT Series)

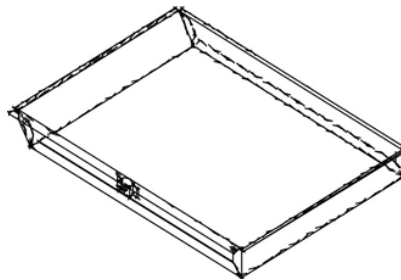

**(37) Baffle Assembly, Ceramic Fiber Brick**  
(above secondary air tubes)  
(CI2000HT Series)

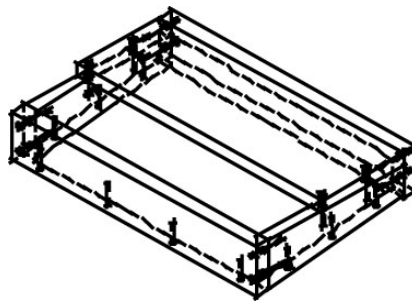

**(38) Start-up Air Channel Assembly**  
(CI2000HT Series)



**(39) Flue Outlet Collar**  
(CI1000HT Series)

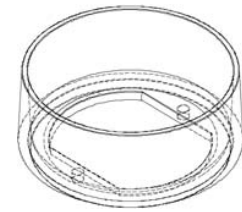

**(40) Flue Outlet Collar**  
(CI2000HT Series)

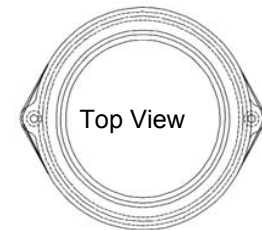
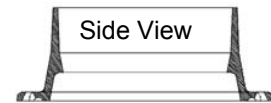

**(41) Fire Poker**  
(CI1000HT & CI2000HT Series)



**(42) Ashpan, Side Door and Firebox Door Handle Receivers**  
(CI1000HT & CI2000HT Series)

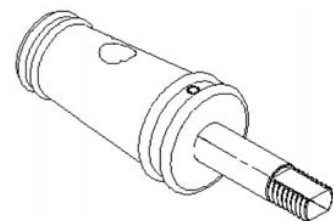

**REPLACEMENT PARTS - Models: CI1000HT & CI2000HT**

**(43) Secondary Air Tube Assembly**  
(CI1000HT Series)

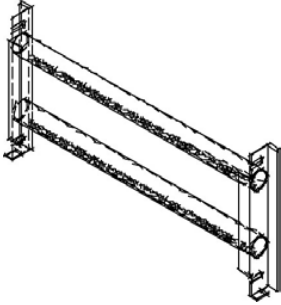

**(45) Air Control/Ash Pan Removal Tool**  
(CI1000HT & CI2000HT Series)

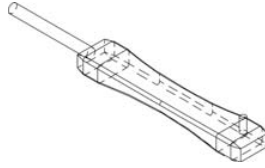

**(48) Draft Module (Air Intake Slide)**  
(CI2000HT Series)

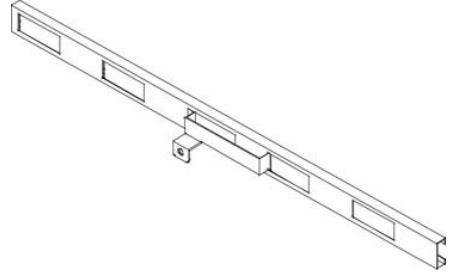

**(46) Removable Door Opener Tool**  
(CI1000HT & CI2000HT Series)



**(44) Secondary Air Tube Assembly**  
(CI2000HT Series)

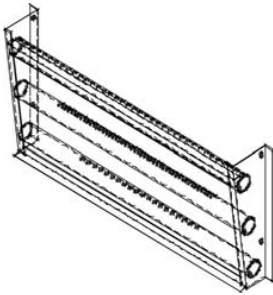

**(47) Draft Module (Air Intake Slide)**  
(CI1000HT Series)

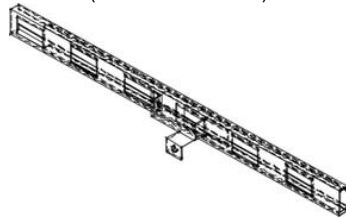

**(49) Rear Firebrick Retainers**  
(CI2000HT Series)  
*Side Retainers Not Shown*

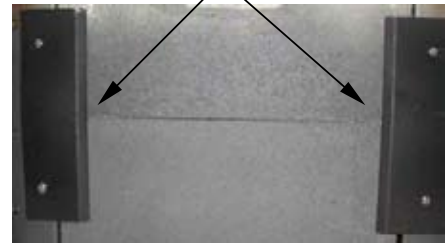

**CI1000HT Firebrick Placement Diagram**

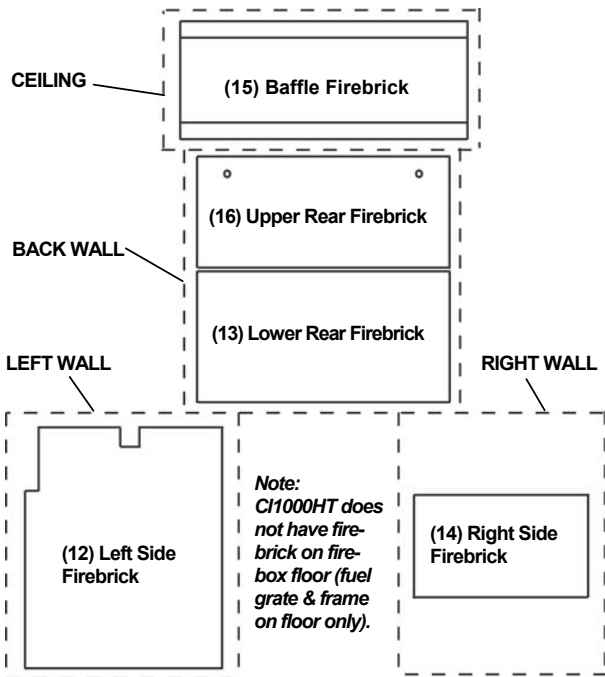

**CI2000HT Firebrick Placement Diagram**

*Note: The refractory baffle assembly (37) on ceiling (above tubes), not shown.*

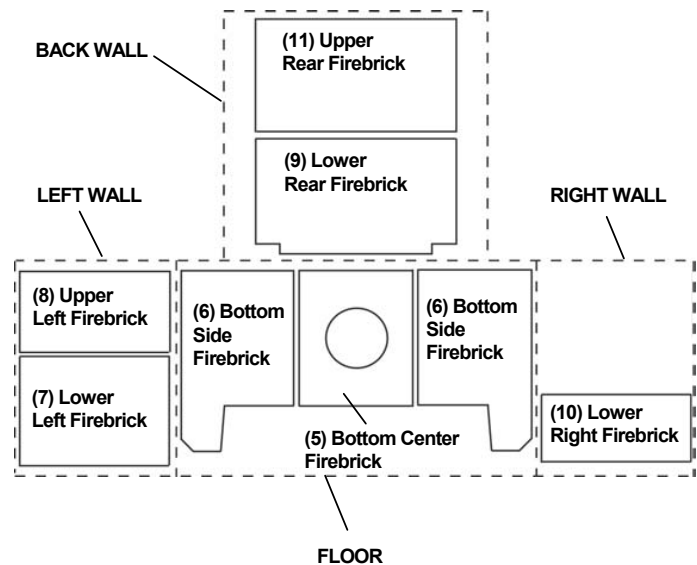

**OPTIONAL ACCESSORIES - Models CI1000HT & CI2000HT**

<b>Catalog No.</b>	<b>Model</b>	<b>Description</b>	<b>Stove Model</b>
41M2401	WTK-CI10	Window Trim Kit, Charcoal	CI1000HT
41M2001	WTK-CI20	Window Trim Kit, Charcoal	CI2000HT

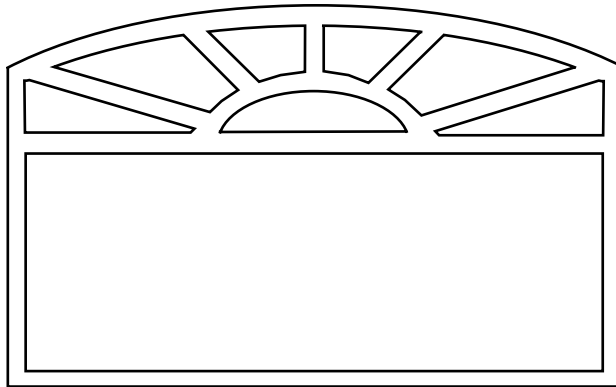







Manufactured in Belgium for LENNOX HEARTH PRODUCTS  
 1110 West Taft Avenue Orange, CA 92865

Model : CI 1000 HT

**US ENVIRONMENTAL PROTECTION AGENCY**

MEETS EPA PARTICULATE MATTER (SMOKE) CONTROL REQUIREMENTS FOR NONCATALYTIC WOOD HEATERS BUILT ON OR AFTER JULY 1, 1990.

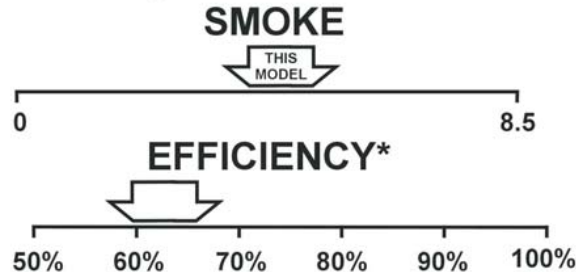

Wood heaters with higher efficiencies cost less to operate  
 \*(NOT TESTED FOR EFFICIENCY. THE VALUE INDICATED IS FOR SIMILAR NONCATALYTIC WOOD HEATERS.)

**HEAT OUTPUT**  
 11,800 to 55,000 Btu/h

Use this to choose the right size appliance for your needs.  
 ASK DEALER FOR HELP  
 This wood heater will achieve low smoke output and high efficiency only if properly operated and maintained. See owner's manual.

**CAUTION:**  
 Remove this label before you light the fire in the stove

775113M, Rev. NC

Manufactured in Belgium for LENNOX HEARTH PRODUCTS  
 1110 West Taft Avenue Orange, CA 92865

Model : CI 2000 HT

**US ENVIRONMENTAL PROTECTION AGENCY**

MEETS EPA PARTICULATE MATTER (SMOKE) CONTROL REQUIREMENTS FOR NONCATALYTIC WOOD HEATERS BUILT ON OR AFTER JULY 1, 1990.

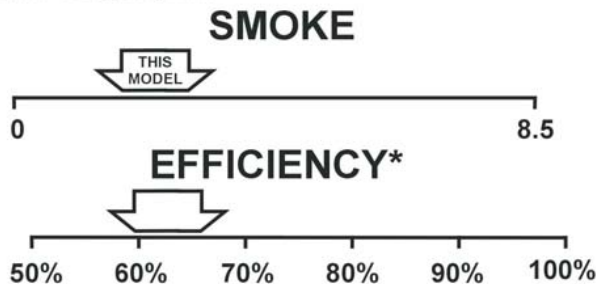

Wood heaters with higher efficiencies cost less to operate  
 \*(NOT TESTED FOR EFFICIENCY. THE VALUE INDICATED IS FOR SIMILAR NONCATALYTIC WOOD HEATERS.)

**HEAT OUTPUT**  
 11,923 to 60,897 Btu/h

Use this to choose the right size appliance for your needs.  
 ASK DEALER FOR HELP  
 This wood heater will achieve low smoke output and high efficiency only if properly operated and maintained. See owner's manual.

**CAUTION:**  
 Remove this label before you light the fire in the stove

775110M, Rev. NC



## WARRANTY

Your wood appliance is covered by a limited warranty (provided with appliance). Please read the warranty to be familiar with its coverage.

Retain this manual. File it with your other documents for future reference.

## PRODUCT REFERENCE INFORMATION

We recommend that you record the following important information about your fireplace. Please contact your Lennox Hearth Products dealer for any questions or concerns. For the number of your nearest Lennox Hearth Products dealer, please call 1-800-9-Lennox.

## REPLACEMENT PARTS

See **Pages 24 to 30** for a complete replacement parts list. Use only parts supplied from the manufacturer.

Normally, all parts should be ordered through your Lennox Hearth Products distributor or dealer. Parts will be shipped at prevailing prices at time of order.

When ordering repair parts, always give the following information:

1. The model number of the appliance.
2. The serial number of the appliance.
3. The part number.
4. The description of the part.
5. The quantity required.
6. The installation date of the appliance.

If you encounter any problems or have any questions concerning the installation or application of this system, please contact your dealer.

## LENNOX HEARTH PRODUCTS

1110 West Taft Avenue  
Orange, CA 92865  
Visit us at [www.Lennox.com](http://www.Lennox.com)

Your Stove's Model Number \_\_\_\_\_

Your Stove's Serial Number \_\_\_\_\_

The Date On Which Your Stove Was Installed \_\_\_\_\_

Your Dealer's Name \_\_\_\_\_



We recommend that our woodburning hearth products be installed and serviced by professionals who are certified in the U.S. by the National Fireplace Institute® (NFI) as NFI Woodburning Specialists or who are certified in Canada by Wood Energy Technical Training (WETT).



Nous recommandons que nos poêles à bois soient installés et que l'entretien soit effectué par des professionnels certifiés, aux Etats-Unis par le National Fireplace Institute® (NFI) et au Canada, par le Wood Energy Technical Training (WETT).



Lennox reserves the right to make changes at any time, without notice, in design, materials, specifications, prices and also to discontinue colors, styles and products. Consult your local distributor for fireplace code information.

# LENNOX™

## HEARTH PRODUCTS

1110 West Taft Avenue • Orange, CA 92865