



FREESTANDING VENTED GAS FIRED ROOM HEATERS

These appliances may be installed in an aftermarket permanently located, manufactured (mobile) home, where not prohibited by local codes.

Tested &
Listed By



Beaverton
Oregon USA

OMNI-Test Laboratories, Inc.

Report No. 116-S-08-5

INSTALLATION INSTRUCTIONS MANUAL



Model CI1500DVF Series



Model CI2500DVF Series

Serrefina Series Direct Vent Gas Stoves

P/N 775,147M Rev C, 11/04

WARNING: IF THE INFORMATION IN THIS MANUAL IS NOT FOLLOWED EXACTLY, A FIRE OR EXPLOSION MAY RESULT CAUSING PROPERTY DAMAGE, PERSONAL INJURY OR LOSS OF LIFE.

FOR YOUR SAFETY: Do not store or use gasoline or other flammable vapors or liquids in the vicinity of this or any other appliance.

FOR YOUR SAFETY: What to do if you smell gas:

- DO NOT light any appliance.
- DO NOT touch any electrical switches.
- Do not use any phone in your building.
- Immediately call your gas supplier from a neighbor's phone. Follow your gas suppliers instructions.
- If your gas supplier cannot be reached, call the fire department.

Installation and service must be performed by a qualified installer, service agency or the gas supplier.

AVERTISSEMENT: ASSUREZ-VOUS DE BIEN SUIVRE LES INSTRUCTIONS DONNÉ DANS CETTE NOTICE POUR RÉDUIRE AU MINIMUM LE RISQUE D'INCENDIE OU POUR ÉVITER TOUT DOMMAGE MATÉRIEL, TOUTE BLESSURE OU LA MORT.

POUR VOTRE SÉCURITÉ: Ne pas entreposer ni utiliser d'essence ni d'autre vapeurs ou liquides inflammables dans le voisinage de cet appareil ou de tout autre appareil.

POUR VOTRE SÉCURITÉ: Que faire si vous sentez une odeur de gaz:

- Ne pas tenter d'allumer d'appareil.
- Ne touchez à aucun interrupteur. Ne pas vous servir des téléphones se trouvant dans le bâtiment où vous vous trouvez.
- Evacuez la pièce, le bâtiment ou la zone.
- Appelez immédiatement votre fournisseur de gaz depuis un voisin. Suivez les instructions du fournisseur.
- Si vous ne pouvez rejoindre le fournisseur de gaz, appelez le service des incendies.

L'installation et service doit être exécuté par un qualifié installateur, agence de service ou le fournisseur de gaz.

CONGRATULATIONS ON THE PURCHASE OF YOUR NEW GAS APPLIANCE MANUFACTURED BY LENNOX HEARTH PRODUCTS.

When you purchased your new gas fired heater, you joined the ranks of thousands of concerned individuals whose answer to their home heating needs reflects their concern for aesthetics, efficiency and our environment. We extend our continued support to help you achieve the maximum benefit and enjoyment available from your new gas fired heater. It is our goal at Lennox Hearth Products to provide you, our valued customer, with an appliance that will ensure you years of trouble free warmth and pleasure.

Thank you for selecting a Lennox Hearth Products gas fired heater as the answer to your home heating needs.

Sincerely,
All of us at Lennox Hearth Products

TABLE OF CONTENTS

Packaging	page 2
Introduction	page 2
General Information	page 2
High Altitude	page 3
Location	page 3
Specifications.....	page 4
Appliance and Vent Clearances	page 5
Manufactured Home Requirements.....	page 6
Vent Termination Clearances	page 6
Typical Installation Sequence	page 8
Step 1 Preparation.....	page 8
Step 2 Remove Packaging	page 8
Step 3 Remove Stove From Pallet	page 8
Step 4 Remove Front Glass	page 8
Step 5 Remove Firebox Contents	page 8
Step 6 Remove Cardboard Pkg.	page 9
Step 7 Install LP Conv./Options	page 9
Step 8 Install Lower Access Door	page 9
Step 9 Install Venting	page 9
Step 10 Connect Gas Line.....	page 13
Step 11 Install Log Set	page 13
Step 12 Reinstall Front Glass	page 14
Step 13 Perform Leak Test.....	page 14
Step 14 Check Appliance Operation.....	page 14
Step 15 Adjust Burner	page 15
Step 16 Install Top, Trivet & Ash Lip.....	page 16
Rating Plates.....	page 17

This installation manual will help you obtain a safe, efficient, dependable installation for your appliance and vent system.

Please read and understand these instructions before beginning your installation.

These Millivolt appliances are listed by OMNI-Test Laboratories Inc. for installation in bedrooms and manufactured (mobile) homes.

PACKAGING LIST

The assembled vented gas stove heater is packaged with:

- one - log set located in firebox
- one - ember strip located beneath stove body (on pallet)
- one - bag of glowing embers located in the firebox
- one - envelope containing the literature package which consists of the homeowner's manual, installation instructions and warranty; located on the top of the firebox
- one - cast iron top
- one - trivet
- one - natural gas to propane conversion kit
- one - ash lip
- one - lower access door
- four - leg levelers

INTRODUCTION

These vented gas heaters are sealed combustion, air circulating gas stoves designed for residential applications. These appliances must be installed with "Security Secure Vent™" or "Simpson Dura Vent" brand vent systems routed to the outside atmosphere (other brands may not be used).

Millivolt appliances are designed to operate on natural or propane gas. A millivolt gas control valve with piezo ignition system provides safe, efficient operation. External electrical power is required to operate the optional blower if installed on these units.

These appliances comply with National Safety Standards and are tested and listed by OMNI-Test Laboratories Inc.; Beaverton, Oregon (Report No. 116-S-08-05) to ANSI Z21.88-2002 (in Canada, CSA-2.33-2002), and CAN/CGA-2.17-M91 in both USA and Canada, as vented gas heaters.

Installation must conform to local codes. In the absence of local codes, installation must comply with the current National Fuel Gas Code, ANSI Z223.1. (In Canada, the current CAN-1 B149 installation code.) Electrical wiring must comply with the National Electrical Code ANSI/ NFPA 70 - latest edition. In Canada, the current CSA C22-1 Canadian Electrical Code - latest edition.

DO NOT ATTEMPT TO ALTER OR MODIFY THE CONSTRUCTION OF THE APPLIANCE OR ITS COMPONENTS. ANY MODIFICATION OR ALTERATION MAY VOID THE WARRANTY, CERTIFICATION AND LISTINGS OF THIS UNIT.

GENERAL INFORMATION

Note: Installation and repair should be performed by a qualified service person. The appliance should be inspected annually by a qualified professional service technician. More frequent inspections and cleanings may be required due to excessive lint from carpeting, bedding material, etc. It is imperative that the control compartment, burners and circulating air passage ways of the appliance be kept clean.

S'assurer que le brûleur et le compartiment des commandes sont propres. Voir les instructions d'installation et d'utilisation qui accompagnent l'appareil.

Provide adequate clearances around air openings and adequate accessibility clearance for service and proper operation. Never obstruct the front openings of the appliance.

These appliances are designed to operate on natural or propane gas only.

These millivolt models come standard with the manually-modulated gas valve; flame appearance and heat output can be controlled at the gas valve.

Table 1 shows the BTU input for each model:

Input (BTU/HR) Manually-Modulated Gas Valves (millivolt models)		
Models	Nat. Gas	Propane
C11500DVF	17,500 to 28,000	20,500 to 27,000
C12500DVF	25,500 to 38,500	26,500 to 34,500

Table 1

Tables 2 and 3 show the units' gas pressure requirements:

Inlet Gas Supply Pressure (all models)		
Fuel #	Minimum	Maximum
Natural Gas	4.5" WC (1.12 kPa)	10.5" WC (2.61 kPa)
Propane	11.0" WC (2.73 kPa)	13.0" WC (3.23 kPa)

Table 2

Manifold Gas Supply Pressure (millivolt models)		
Fuel #	Low	High
Natural Gas	(Lo) 1.6" WC (.40 kPa)	(Hi) 3.5" WC (.87 kPa)
Propane	(Lo) 6.3" WC (1.57 kPa)	(Hi) 10.0" WC (2.49 kPa)

Table 3

Installations at Altitudes of 0 to 4500 feet - Units are tested and approved for elevations of 0 to 4500 feet (0 to 1370 meters).

Installations at Altitudes above 4500 ft. - For elevations above 4500 feet (1370 meters), install the unit according to the regulations of the local authorities having jurisdiction and, in the USA, the latest edition of the National Fuel Gas Code (ANSI Z223.1) or, in Canada, the latest edition of the CAN-B149.1 and CAN-B149.2 codes.

Table 4 shows the units' gas orifice size for the elevations indicated:

Burner Orifice Sizes			
Model No.	Nat. Gas	Prop. Gas	Elevation Feet (meters)
CI1500DVF	.104"	.061"	0-4500 (0-1372)
CI2500DVF	.121"	.068"	0-4500 (0-1372)

Table 4

The millivolt appliances are manually controlled and feature a spark igniter (piezo) that allows the appliance's pilot gas to be lit without the use of matches or batteries. This system provides continued service in the event of a power outage.

Do not use these appliances if any part has been under water. Immediately call a qualified, professional service technician to inspect the appliance and to replace any parts of the control system and any gas controls which have been under water.

Ne pas se servir de cet appareil s'il a été plongé dans l'eau, complètement ou en partie. Appeler un technicien qualifié pour inspecter l'appareil et remplacer toute partie du système de contrôle et toute commande qui ont été plongés dans l'eau.

This appliance may be installed in an aftermarket permanently located, manufactured home (USA only) or mobile home, where not prohibited by local codes.

Cet appareil peut être installé dans un maison préfabriquée (É.-U. seulement) ou mobile déjà installée à demeure si les règlements locaux le permettent.

Test gauge connections are provided on the front of the millivolt gas control valve (identified IN for the inlet and OUT for the manifold side).

These appliances and their individual shut-off valves must be disconnected from the gas supply piping system during any pressure testing of that system at pressures in excess of 1/2 psig (3.5 kPa).

These appliances must be isolated from the gas supply piping system (by closing their individual manual shut-off valve) during any pressure testing of the gas supply piping system at test pressures equal to or less than 1/2 psig (3.5 kPa).

These appliances must not be connected to a chimney or flue serving a separate solid fuel burning appliance.

WARNING: This appliance must be properly connected to a venting system. Operation of this gas appliance when not connected to a properly installed and maintained venting system can result in carbon monoxide (CO) poisoning and possible death.

Carbon Monoxide Poisoning: Early signs of carbon monoxide poisoning are similar to the flu with headaches, dizziness and/or nausea. If you have these signs, obtain fresh air immediately. Turn off the gas supply to the appliance and have it serviced by a qualified professional, as it may not be operating correctly.

WARNING: FAILURE TO COMPLY WITH THE INSTALLATION AND OPERATING INSTRUCTIONS PROVIDED IN THIS DOCUMENT WILL RESULT IN AN IMPROPERLY INSTALLED AND OPERATING APPLIANCE, VOIDING ITS WARRANTY. ANY CHANGE TO THIS APPLIANCE AND/OR ITS OPERATING CONTROLS IS DANGEROUS. IMPROPER INSTALLATION OR USE OF THIS APPLIANCE CAN CAUSE SERIOUS INJURY OR DEATH FROM FIRE, BURNS, EXPLOSION OR CARBON MONOXIDE POISONING.

WARNING: DO NOT PLACE CLOTHING OR OTHER FLAMMABLE MATERIALS ON OR NEAR THIS APPLIANCE.

WARNING: CHILDREN AND ADULTS SHOULD BE ALERTED TO THE HAZARDS OF HIGH SURFACE TEMPERATURES. USE CAUTION AROUND THE APPLIANCE TO AVOID BURNS OR CLOTHING IGNITION. YOUNG CHILDREN SHOULD BE CAREFULLY SUPERVISED WHEN THEY ARE IN THE SAME ROOM AS THE APPLIANCE.

AVERTISSEMENT: SURVEILLER LES ENFANTS. GARDER LES VÊTEMENTS, LES MEUBLES, L'ESSENCE OU AUTRES LIQUIDES À VAPEUR INFLAMMABLES À CÔTÉ DE L'APPAREIL.

LOCATION

In selecting the location, the aesthetic and functional use of the appliance are primary concerns. However, vent system routing to the exterior and access to the fuel supply are also important. Consideration should be given to traffic ways, furniture, draperies, etc., due to elevated surface temperatures.

Considerations Should Include:

- Existing Chimneys
- Aesthetic Considerations
- Roof Design (Rafters Locations & Roof Pitch)
- Room Traffic
- Proximity to Combustibles
- Proximity for Optimum Heat Transfer
- Electrical Wiring (if optional blower is installed)

The installation of this stove will require some research. Once your options are determined, consult with your local building department who will be able to give you the necessary installation requirements for your area (Is a building permit required?, Rooms where installation may not be allowed?, etc.).

SPECIFICATIONS

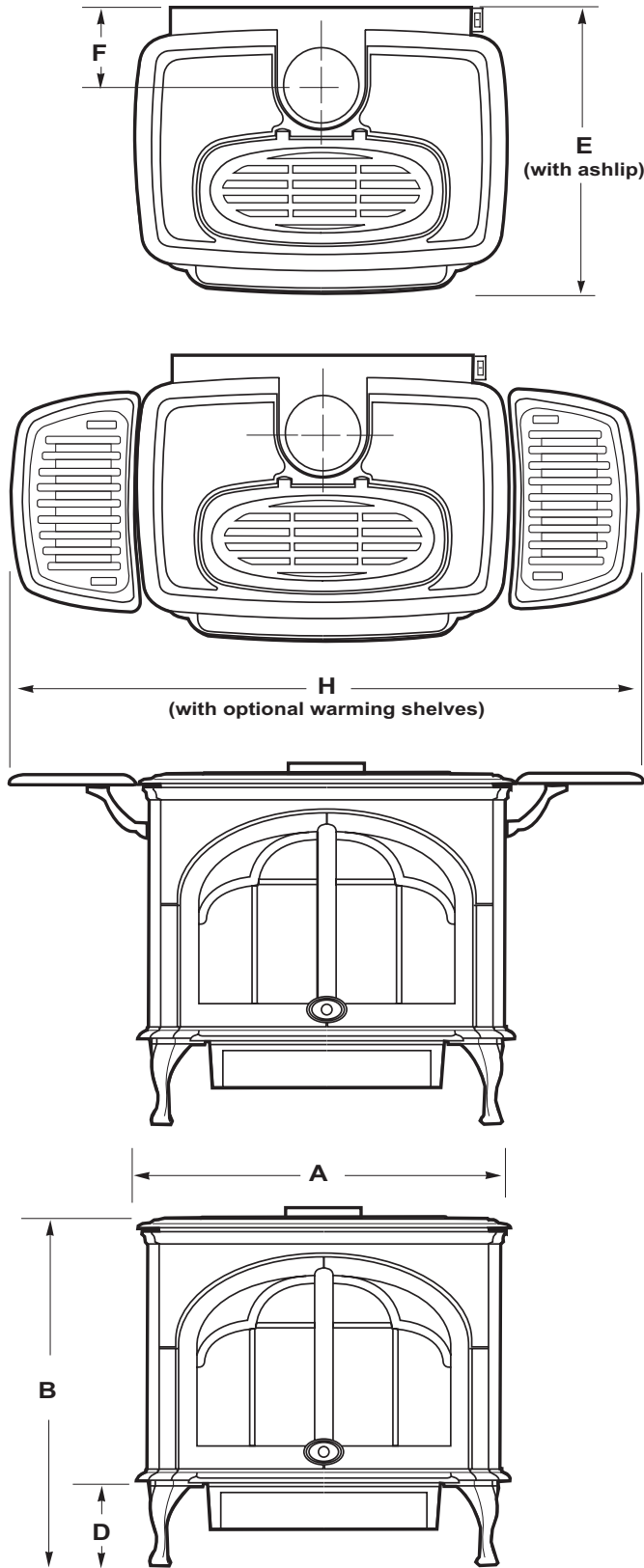

DIMENSIONS		
	CI1500DVF	CI2500DVF
A	24-1/2" (622 mm)	30-1/2" (775 mm)
B	27-1/2" (699 mm)	28-1/2" (724 mm)
C	19" (483 mm)	22" (559 mm)
D	7" (178 mm)	7" (178 mm)
E	20-1/2" (521 mm)	23-1/2" (597 mm)
F	6" (152 mm)	6" (152 mm)
G	28" (711 mm)	29" (737 mm)
H	40" (1016 mm)	48-1/2" (1232 mm)

SPECIFICATIONS		
	CI1500DVF	CI2500DVF
Min./Max BTU/hr Input - NG	17,500 / 28,000	25,500 / 38,500
Min./Max BTU/hr Input - LP	20,500 / 27,000	26,500 / 34,500
DV Vent Size	4" inner / 6 5/8" outer	4" inner / 6 5/8" outer
Room Fan CFM	150	150
Weight (lb)	206	290

EFFICIENCIES		
	CI1500DVF	CI2500DVF
ENERGUIDE	67% (NG) 65% (LP)	67% (NG) 64% (LP)
Steady State Efficiency *	85% (NG) 87% (LP)	83% (NG) 85% (LP)

*Based on maximum vent configuration.

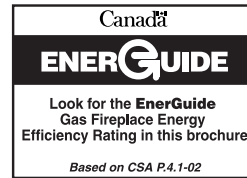

Note: Due to Lennox' ongoing commitment to quality, all specifications, ratings and dimensions are subject to change without notice.

Figure 1

CLEARANCES TO COMBUSTIBLE MATERIALS / FLOOR PROTECTION

- The location should also be free of electrical, plumbing or other heating/air conditioning ducting.
- Due to high temperatures, this appliance should be located out of traffic and away from furniture, draperies and not in windy or drafty areas.
- This appliance can be installed in most residential room configurations, parallel to a rear or adjacent wall, or in an alcove that allows for the minimum clearances to combustibles surfaces. Your local building inspector should review your plans prior to installation.
- When installing this appliance, provide adequate clearances for the purposes of servicing and proper operation.
- As determined through the safety certification of this unit, a minimum clearance to combustible materials must be maintained around specific areas of the gas appliance. (See Table 5 & Figure 2)

CLEARANCES		
	CI1500DVF	CI2500DVF
A (minimum)	*10" (254 mm)	*10" (254 mm)
B (minimum)	*14-1/4" (362 mm)	*17-1/4" (438 mm)
C (minimum)	*15-7/8" (403 mm)	*19" (483 mm)
D (minimum)	4" (102 mm)	4" (102 mm)
E (minimum)	2" (51 mm)	2" (51 mm)
F (minimum)	4" (102 mm)	4" (102 mm)
G (minimum)	0" (0 mm)	0" (0 mm)
H (minimum)	***62" (1575 mm)	***62" (1575 mm)
I (minimum)	**28 1/2" (724 mm)	**34 1/2" (876 mm)
J (MAXIMUM)	48" (1219 mm)	48" (1219 mm)

Table 5

* Dimensions with a single asterisk are reference dimensions only.

** If the optional warming shelves are installed, a greater alcove width is required as follows:

CI1500DVF - 44" (1118 mm) min.
CI2500DVF - 52 1/2" (1334 mm) min.

***This includes any projections such as shelves, windowsills, mantels, etc. above the appliance.

Note: Recommended clearance zone from the front of the appliance to combustibles is 36 inches (914 mm) minimum.

Floor Protection

When installed directly on carpeting, tile (see Note below) or other combustible material other than wood flooring, the appliance shall be installed on a metal or wood panel extending the full width and depth of the stove body.

Note: Ceramic tile is non-combustible and does not require a wood or metal panel under the appliance.

Vent Clearances - All Models

For Horizontal Sections:

Top - 3" (76.2 mm) min.
Sides - 1" (25.4 mm) min.
Bottom - 1" (25.4 mm) min.

At Wall Firestops:

Top - 3" (76.2 mm) min.
Sides - 1" (25.4 mm) min.
Bottom - 1/2" (12.7 mm) min.

For Vertical Sections:

Sides - 1" (25.4 mm) min.

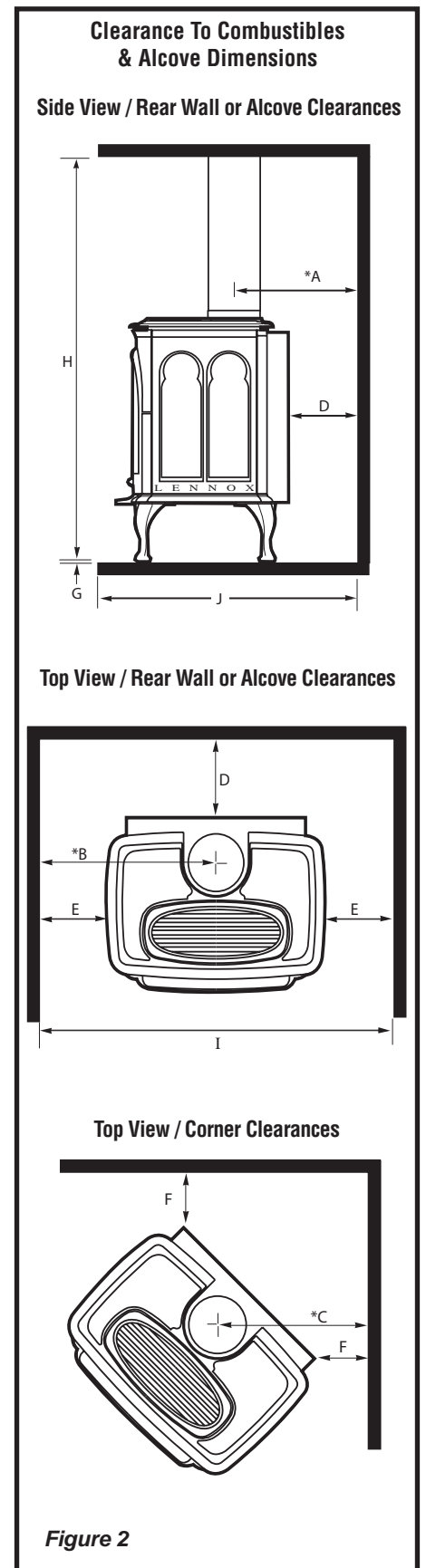

MANUFACTURED (MOBILE) HOME REQUIREMENTS

These models may be installed in an after-market permanently located, manufactured home, where not prohibited by local codes. When installed in Manufactured Housing the following supplemental requirements must be met:

- The appliance must be secured to the floor (i.e. use (4) ¼" x 2 ¾" bolts and nuts or equivalent. Note: Not included) for securing appliance to the manufactured home floor.
- The appliance must be grounded to the chassis of the manufactured home. Use a No. 8 or heavier copper wire at least 18" in length.
- The structural integrity of the manufactured home floor, walls, ceiling and roof must be maintained.
- A manufactured (mobile) home installation must conform with the Manufactured Home Construction and Safety Standard, Title 24 CFR, Part 3280, or, when such a standard is not applicable, the Standard for Manufactured Home Installations, ANSI / NCSBCS A225.1, or standard for Gas equipped Recreational Vehicles and Mobile Housing, CSA Z240.4.

QUESTIONS TO ASK LOCAL BUILDING OFFICIAL

This appliance must be installed per manufacturers' instructions.

Installations must conform to appropriate local codes and applicable state and federal requirements. Familiarity with these requirements before installation is essential. Some important considerations to discuss with local building officials include:

1. Applicable codes (i.e. Uniform Mechanical Code, State or Regional Gas Codes, National Fuel Gas Code)
2. Local amendments
3. Recognized testing lab: OMNI-Test Laboratories Inc.; Beaverton, Oregon
4. Is a permit required - cost?
5. In some states or municipalities, a licensed gas fitter or plumber may be required to install this appliance. Check with your local building official for requirements in your area (i.e. Is a license required for installation of gas supply line)?
6. Maximum amount of gas pipe without a pressure test - type of test required?

7. Are below grade penetrations of the gas line allowed?
8. Is concealed gas piping allowed?
9. Specific requirements of concealed fittings?
10. Is rigid pipe to appliance required?
11. Allowed piping materials?
12. Shut-off valve required within 4 feet of the firebox?
13. May the shut-off valve be concealed?
14. Rooms where the installation is not allowed?

In the absence of local codes, installation should conform to National Fuel Gas Code, ANSI Z223.1 / NFPA 54-Latest Edition in the USA or National Fuel Gas Code, CAN/CGA-B149-Latest Edition in Canada.

VENT TERMINATION CLEARANCES

Vertical Vent Termination Clearances

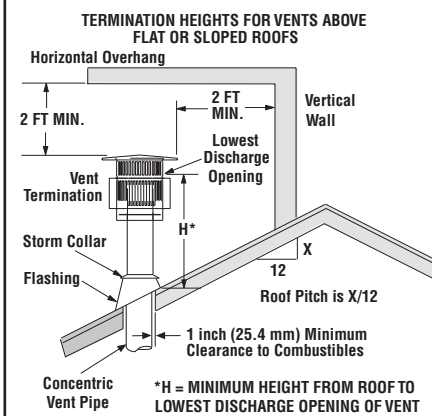

The vent/air intake termination clearances above the high side of an angled roof is as follows:

Roof Pitch	Feet	Meters
Flat to 6/12	1.0	0.3
6/12 to 7/12	1.25	0.38
7/12 to 8/12	1.5	0.46
8/12 to 9/12	2.0	0.61
9/12 to 10/12	2.5	0.76
10/12 to 11/12	3.25	0.99
11/12 to 12/12	4.0	1.22
12/12 to 14/12	5.0	1.52
14/12 to 16/12	6.0	1.83
16/12 to 18/12	7.0	2.13
18/12 to 20/12	7.5	2.29
21/12 to 21/12	8.0	2.44

Figure 3

These instructions should be used as a guideline and do not supersede local codes in any way. Install vent according to local codes, these instructions, the current National Fuel Gas Code (ANSI-Z223.1) in the USA or the current standards of CAN/CGA-B149.1 and -B149.2 in Canada.

Horizontal Vent Termination Clearances

The horizontal vent termination must have a minimum of 3" (76 mm) clearance to any overhead combustible projection of 2 1/2" (64 mm) or less. See Figure 4. For projections exceeding 2 1/2" (64 mm), For additional vent location restrictions refer to Figure 5.

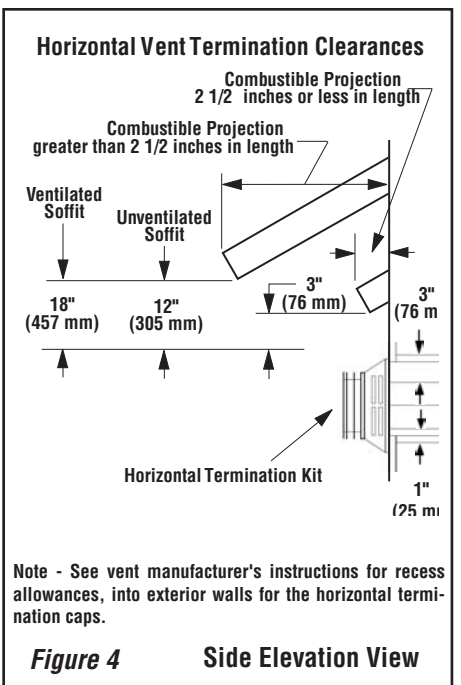
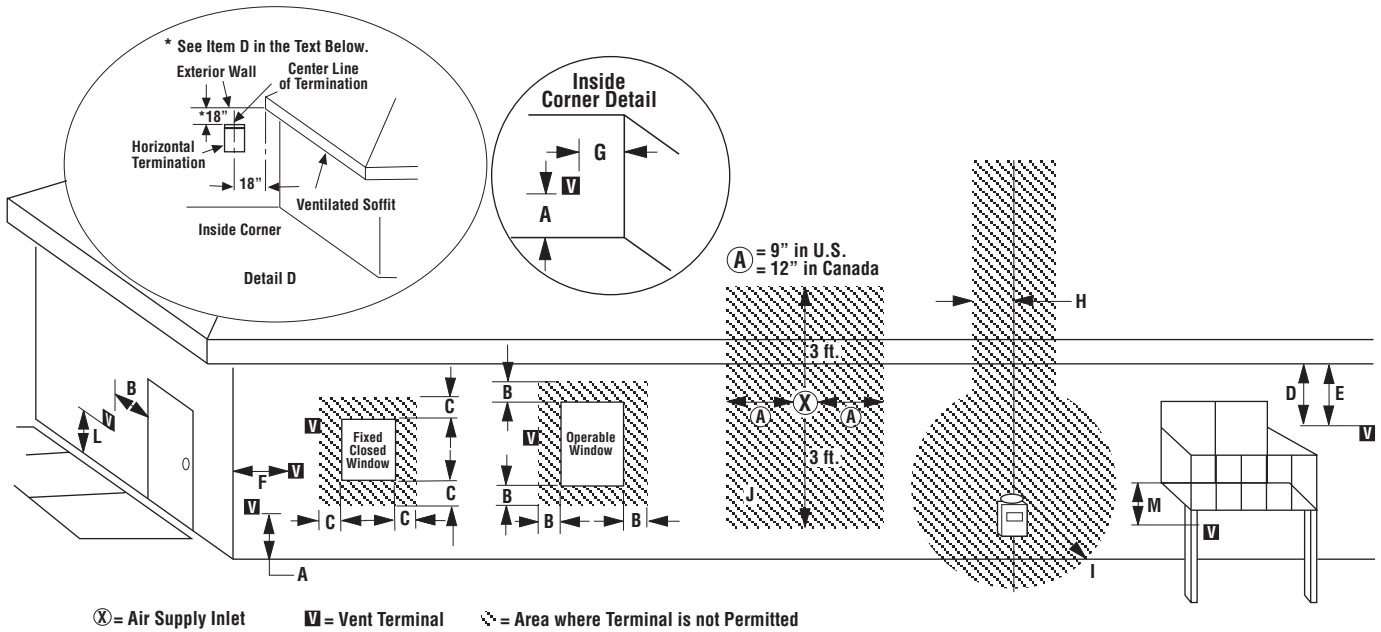

Figure 4 Side Elevation View

EXTERIOR HORIZONTAL VENT TERMINATION CLEARANCE REQUIREMENTS



	Canadian Installation*	US Installation**
A = Clearance above grade, veranda, porch, deck, or balcony.	12 inches (30cm)*	12 inches (30cm)**
B = Clearance to window or door that may be opened.	6 in (15cm) for appliances < 10,000 Btuh (3kW), 12 in (30cm) for appliances > 10,000 Btuh (3kW) and < 100,000 Btuh (30kW), 36 inches (91cm) for appliances > 100,000 Btuh (30kW)*	6 in (15cm) for appliances < 10,000 Btuh (3kW), 9 in (23cm) for appliances > 10,000 Btuh (3kW) and < 50,000 Btuh (15kW), 12 inches (30cm) for appliances > 50,000 Btuh (15kW)**
C = Clearance to permanently closed window	12" (305mm) recommended to prevent window condensation	9" (229mm) recommended to prevent window condensation
D = Vertical clearance to ventilated soffit located above the terminal within a horizontal distance of 18 inches (458mm) from the center line of the terminal	18" (458mm)	18" (458mm)
E = Clearance to unventilated soffit	12" (305mm)	12" (305mm)
F = Clearance to outside corner	5" (12.7cm) minimum	5" (12.7cm) minimum
G = Clearance to inside corner	6" (15.2cm) minimum	6" (15.2cm) minimum
H = Clearance to each inside of center line extended above meter/regulator assembly	3 feet (91cm) within a height of 15 feet above the meter/regulator assembly*	3 feet (91cm) within a height of 15 feet above the meter/regulator assembly**
I = Clearance to service regulator vent outlet	3 feet (91cm)*	3 feet (91cm)**
J = Clearance to nonmechanical air supply inlet to building or the combustion air inlet to any other appliance	6 in (15cm) for appliances < 10,000 Btuh (3kW), 12 in (30cm) for appliances > 10,000 Btuh (3kW) and < 100,000 Btuh (30kW), 36 inches (91cm) for appliances > 100,000 Btuh (30kW)*	6 in (15cm) for appliances < 10,000 Btuh (3kW), 9 in (23cm) for appliances > 10,000 Btuh (3kW) and < 50,000 Btuh (15kW), 12 inches (30cm) for appliances > 50,000 Btuh (15kW)**
K = Clearance to a mechanical air supply inlet	6 feet (1.8m)*	3 feet (91cm) above if within 10 feet (3m) horizontally**
L = Clearance above paved sidewalk or paved driveway located on public property	7 feet (2.13m)‡	7 feet (2.13m)‡
M = Clearance under veranda, porch, deck or balcony	12 inches (30cm)*‡	12 inches (30cm)‡

* In accordance with the current CSA-B149.1 National Gas And B149.2 Propane Installation Code.

** In accordance with the current ANSI SZ223.1/NFPA 54 National Fuel Gas Codes.

‡ A vent shall not terminate directly above a sidewalk or paved driveway which is located between two single family dwellings and serves both dwellings.

*‡ Only permitted if veranda, porch, deck or balcony is fully open on a minimum 2 sides beneath the floor:

Figure 5

TYPICAL INSTALLATION SEQUENCE

See the page numbers references in the following steps for detailed procedures.

The typical sequence of installation follows, however, each installation is unique resulting in variations to those described.

Step 1. (page 8) Preparation - Plan and install gas line, venting system and floor protection (if necessary).

Step 2. (page 8) Remove outer carton. Remove inner packages and packing materials and set aside.

Step 3. (page 8) Remove stove from pallet and place into positioned where unit is to be installed.

Step 4. (page 8) Remove front glass enclosure from stove and set aside.

Step 5. (page 8) Remove packaged materials from inside firebox and set aside (log set, bag of embers and NG to LP conversion kit).

Step 6. (page 9) Remove cardboard packaging material from beneath relief door and discard.

Step 7. (page 9) Install LP Conversion kit (if necessary). Install any optional accessories (excluding firescreens).

Step 8. (page 9) Install lower access door.

Step 9. (page 9) Venting System Installation.

Step 10. (page 13) Connect gas supply line to the appliance. Purge Air.

Step 11. (page 13) Install log set, ember strip and embers.

Step 12. (page 14) Reinstall front glass enclosure.

Step 13. (page 14) Test all connections for leaks (factory and field).

Step 14. (page 14) Check appliance for proper operation.

Step 15. (page 15) Adjust burner to ensure proper flame appearance.

Step 16. (page 16) Install stove top, trivet and ash lip.

DETAILED INSTALLATION STEPS

Step 1: PREPARATION - Plan and install gas line and floor protection (if necessary - see Floor Protection, page 5).

Gas Supply Line (reference Figure 18 on page 13) - Installing a gas supply line from the fuel supply to the appliance involves numerous considerations of materials, protection, sizing, locations, controls, pressure, sediment, and more. Certainly no one unfamiliar and unqualified should attempt sizing or installing gas piping.

The gas supply line should be plumbed from the fuel source to the area where the appliance is to be installed per requirements outlined in NFPA 54 - latest edition (USA) and B149 - latest edition (Canada).

The proper gas line diameter must be used to run from the supply regulator (at the gas company meter) to the appliance. Never use galvanized or plastic pipe. Refer to table 6 for suggested sizing of the gas supply line if black iron pipe is being used.

The gas supply line should be connected to the appliance at step 10.

**Suggested Sizing of Black Iron Pipe
Schedule 40 - Pipe Supply Line**

Schedule 40 Pipe Length (Feet)	Schedule 40 Pipe Inside Diameter (Inches)	
	Natural Gas	Propane Gas
0-10	1/2	3/8
10-40	1/2	1/2
40-100	1/2	1/2
100-150	3/4	1/2
150-200	3/4	1/2

Table 6

IMPORTANT NOTE: If propane is used, be aware that if the tank size is too small (i.e. under 100-lbs, if this is the only gas appliance in the dwelling. Ref. NPFA 58), there may be loss of pressure, resulting in insufficient fuel delivery (which can result in sooting or other malfunctions). Any damage resulting from an improper installation, such as this, is not covered under the limited warranty.

Step 2: REMOVE PACKAGING - Remove the large outer carton. Remove all the inner packages and packing materials and set aside. To remove the ember strip package below the stove body, carefully cut the 2 plastic ties using scissors.

Step 3: REMOVE FROM PALLET -

A. Remove the trivet, then the cast iron stove top by carefully lifting them up and off and setting them aside (**READ CAUTION BELOW**).

CAUTION: THE CAST IRON STOVE TOP IS VERY HEAVY AND MAY REQUIRE A MINIMUM OF TWO PEOPLE TO LIFT; ONE PERSON ON EACH SIDE (THE C11500 SERIES CAST TOP WEIGHS ~20 POUNDS AND THE C12500 SERIES CAST TOP WEIGHS ~40 POUNDS).

B. Remove stove body from pallet (**READ CAUTION BELOW**).

CAUTION: THE STOVE BODY IS VERY HEAVY. THE USE OF A HEAVY DUTY ESCALARA (STAIR STEP HAND TRUCK) IS RECOMMENDED FOR LIFTING THE STOVE BODY.

Remove the screws and support plate which secure the stove legs to the pallet. Lift stove off of the pallet and place it into position (where unit is to be installed).

Note: Install Leg Leveling Bolts if Necessary:

The four leg leveling bolts (included in literature package), are provided for leveling the stove if necessary. To install, thread the bolts into the existing holes in the bottom of each leg. Turn the leveling bolts to adjust for correct height.

Step 4: REMOVE FRONT GLASS ENCLOSURE PANEL - Remove the front glass enclosure from stove as follows:

WARNING: HANDLE GLASS WITH EXTREME CARE! THE GLASS PANEL IS SUSCEPTIBLE TO DAMAGE — DO NOT SCRATCH WHILE HANDLING OR WHILE REINSTALLING THE GLASS ENCLOSURE PANEL.

WARNING: NEVER OPERATE APPLIANCE WITHOUT THE FRONT GLASS ENCLOSURE PANEL IN PLACE AND SECURE.

A. Locate and open the 2 latches below the stove body (See Figure 6).

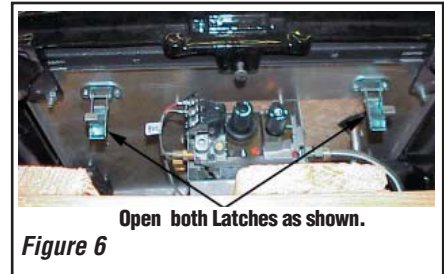

B. Reach under the bottom front of the front glass enclosure and pull it forward as shown in Figure 7.

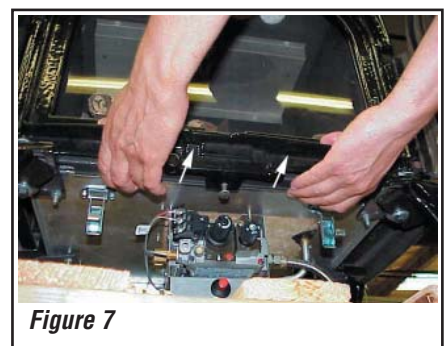

C. Lift glass assembly up and out and carefully set aside in a safe place (see Figure 8).



Step 5: REMOVE MATERIALS FROM FIRE-BOX - Remove the packaged materials from inside of the firebox and set aside (propane conversion kit, log support cartons, log set and embers).

Step 6: REMOVE CARDBOARD - Remove the cardboard packaging material from beneath the relief door and discard (see Figure 9).



Figure 9

Step 7: INSTALL LP CONVERSION KIT (IF NECESSARY) AND OPTIONAL ACCESSORIES

- Install the LP conversion kit and optional accessories per instructions provided with the kits (do not install an optional firescreen or brick liner kit at this point).

- A. Optional accessories include a wall thermostat, blower kit, brick liner kit, warming shelves and a standard or deluxe remote control kits.
- B. If a wall-mounted thermostat is selected, mount it in a convenient location on a wall near the stove. If the warming shelves are being installed, see Homeowners Manual for installation instructions.
- C. Wire the thermostat within the millivolt control circuit using a maximum of 25 feet of 18 gage, 2 conductor wire. Caution: Do not connect the optional wall thermostat, gas control valve or control wiring system of the unit to a 120 volt power supply (residential line voltage)

The gas valve is set in place and pre-wired at the factory on both models (see Figure 11).

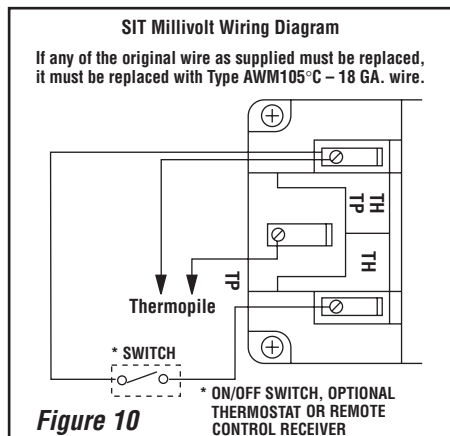

Figure 10

Wiring - Optional Forced Air Blower Kit:

BK-CI (see Figure 11 for wiring diagram) - (An optional field-provided outletbox/J-Box may also be used). Install the blower kit according to the installation instructions provided with the kit.

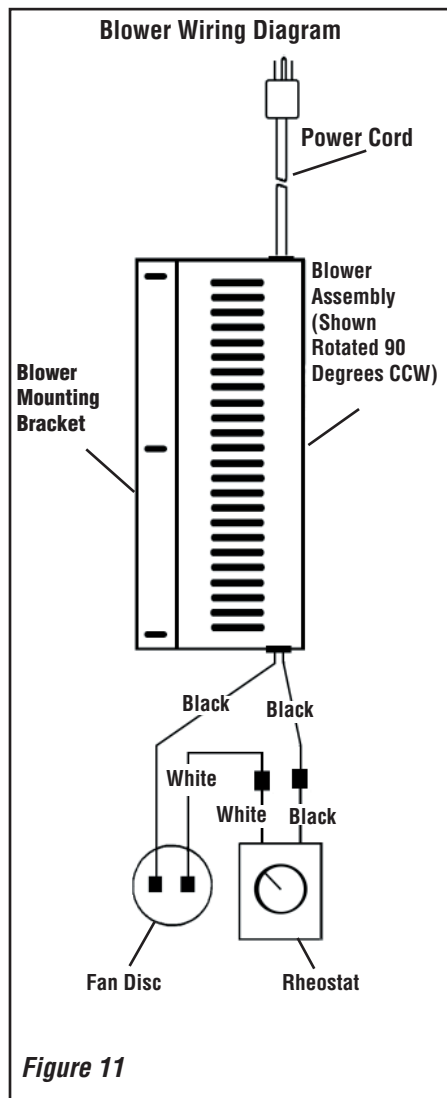

Figure 11

IMPORTANT: Ground supply wire must be connected to the green wire attached to the green ground screw. Failure to do so will result in a potential safety hazard. The appliance must be electrically grounded in accordance with local codes or, in the absence of local codes, the National Electrical Code, ANSI/NFPA 70 - latest edition. In Canada, the current CSA C22-1 Canadian Electrical - latest edition.

WARNING: THE POWER CORD MUST BE PLUGGED DIRECTLY INTO A PROPERLY GROUNDED THREE-PRONG 120 VOLT, 60 HZ WALL RECEPTACLE. Do not cut or remove the grounding prong from this plug. Do not route power cord under or in front of appliance.

NOTE: DIAGRAMS & ILLUSTRATIONS NOT TO SCALE.

Step 8: INSTALL LOWER ACCESS DOOR .

Install the lower access door by inserting the tabs on the door sides into the corresponding holes on the brackets on the stove bottom (see Figure 12 below)

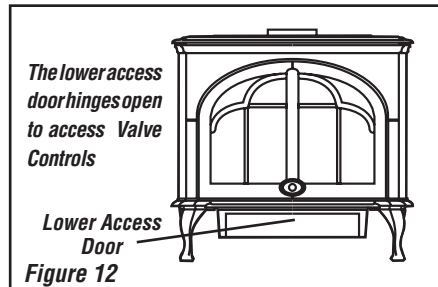

Step 9: VENTING SYSTEM INSTALLATION

INSTALL VENTING COMPONENTS PER VENT MANUFACTURERS INSTRUCTIONS

The vent system may not service multiple appliances, and must never be connected to a flue serving a solid fuel burning appliance.

CAUTION: Under no circumstances should these appliances be vented to other rooms or buildings. These appliances must only be vented to the outside. Vent terminations shall not be recessed into a wall or siding.

IMPORTANT: Do not exceed the maximum horizontal run allowed (see Figure 13 & 14).

Support Brackets - Install vent support brackets as specified in the vent manufacturers instructions and the National Gas Fuel Code, USA - NFPA 54 / ANSI Z223.1, 7.6.5 Support of Gas Vents. Gas vents shall be supported and spaced in accordance with their listings and the (vent) manufacturer instructions.

General Information: These instructions should be used as a guideline and do not supersede local codes in any way. Install vent according to local codes, these instructions, the current National Fuel Gas Code (NFPA 54 / ANSI-Z223.1) in the USA or the current standards of CAN/CGA-B149.1 and -B149.2 in Canada.

These stoves are designed, tested and listed for operation and installation with, and only with, "Security Secure Vent™" or "Simpson Dura Vent" brand Components (co-axial DV pipe with 4" inner & 6 5/8" outer diameter). These approved vent system components are labeled for identification. DO NOT use any other manufacturer's vent components with these appliances. These stoves must be vented directly to the outside.

Horizontal Termination

The vent must rise vertically, a minimum of 24" (610 mm) off the top of the appliance for Natural Gas and 36" for Propane Gas before the first elbow.

The horizontal run may extend up to 20 feet (6 meters) and include a vertical rise of up to 40 feet (12 meters) - see Figure 13. Horizontal termination must meet the criteria shown in Figures 4 and 5.

- Approved vent systems must terminate above and including the heavy line in Figure 13.
- Two 45 degree elbows may be substituted for each single 90 degree elbow.
- With a rise between 2 feet to 5 feet, one 90 degree or two 45 degree elbows may be used.

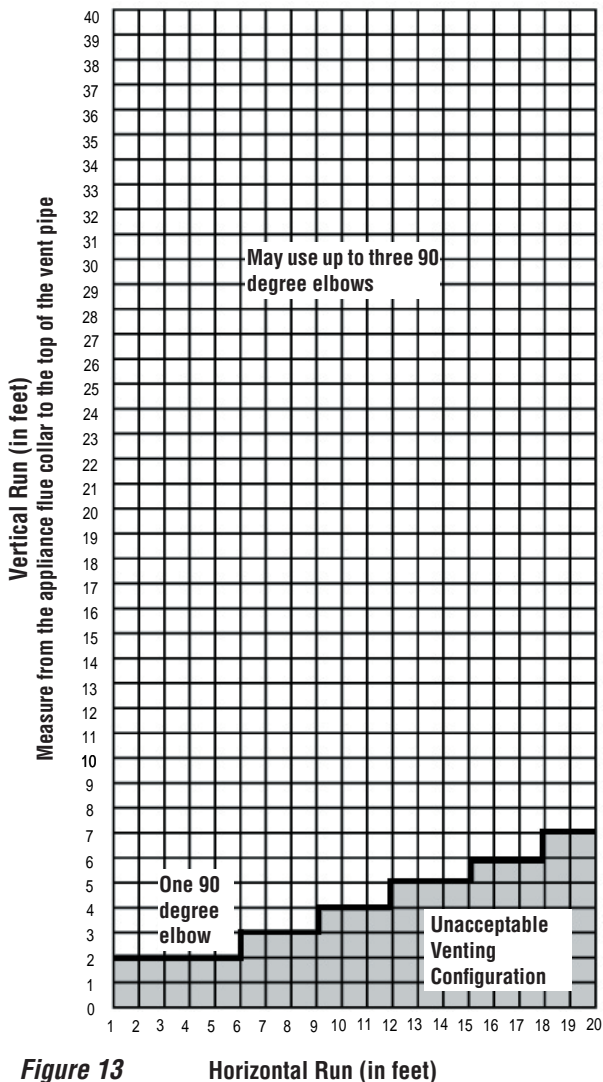

Vertical Termination

A vertical vent system must terminate no less than 8 feet (2.44 meters) and no more than 40 feet / 12 meters (above the appliance flue collar. See Figure 14.

A vertically terminated vent system must also conform to the following criteria:

No more than three 90 degree elbows may be used.

Two 45 degree elbows may be substituted for one 90 degree elbow. No more than six 45 degree elbows may be used.

Vent must rise a minimum of 2 feet before an offset is used.

Termination height must conform to roof clearance as specified in Figure 3

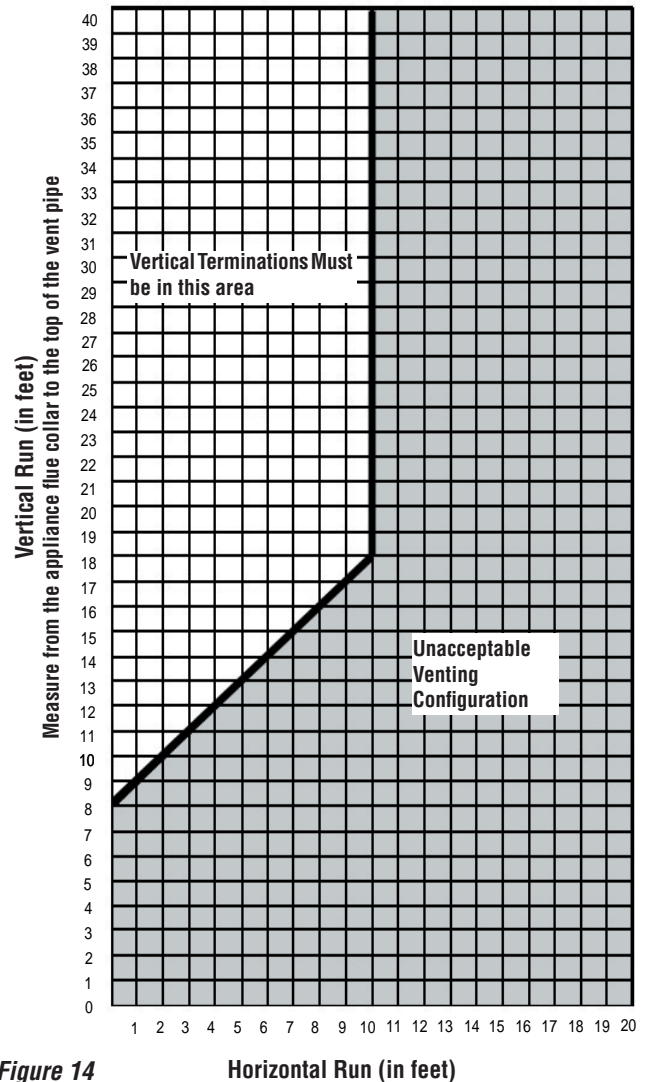

Installing Support Brackets

Install support brackets per vent manufacturers instructions.

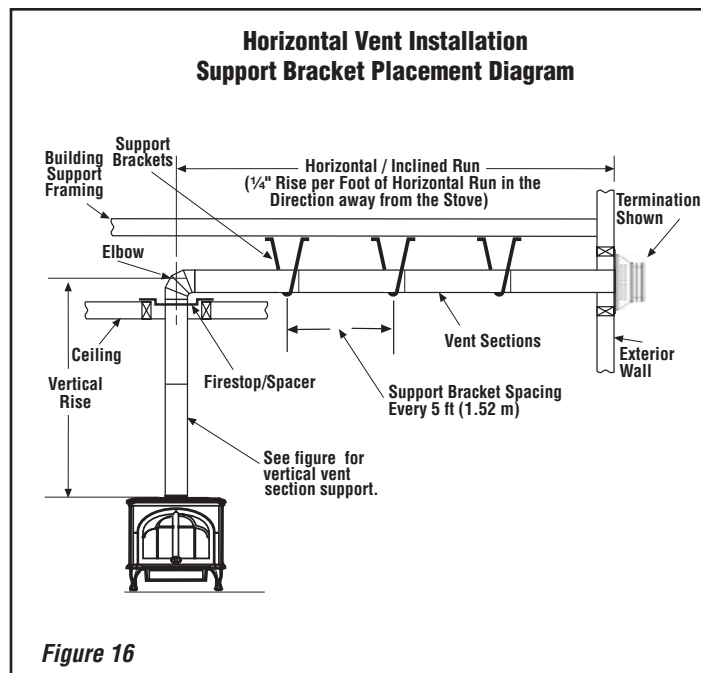
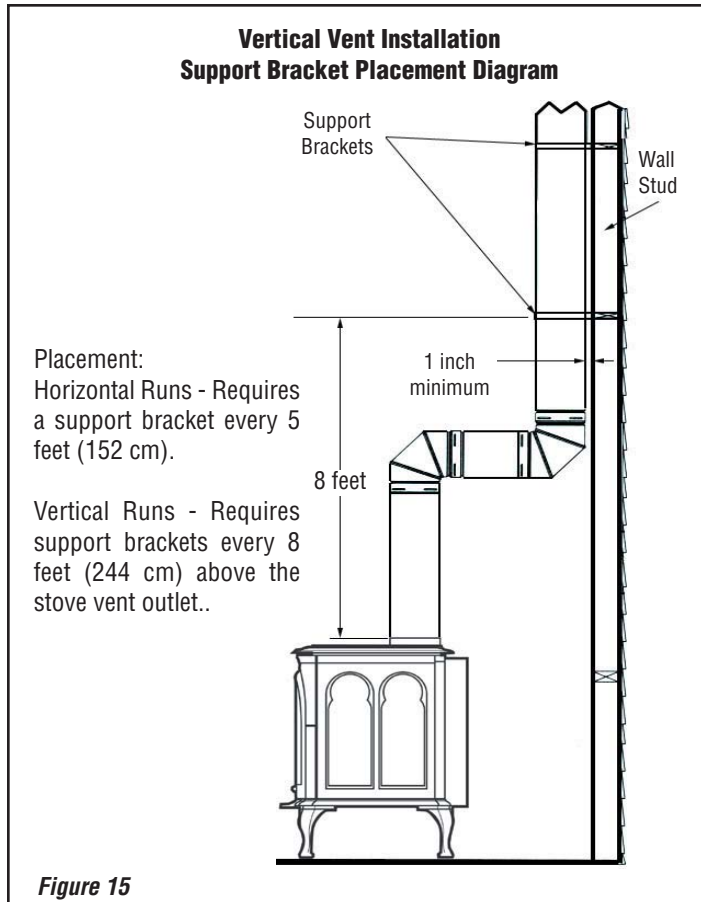

Direct Vent Retrofit Of Existing Chimney System

An existing Class-A (wood-burning) Metal Chimney or Masonry Chimney can be converted to a direct vent system. Use one of the following chimney conversion kits listed below. Have the existing chimney system inspected by a professional prior to the conversion. If using Simpson Dura-Vent brand liner kit, see "IMPORTANT" note at the top of page 12. The chimney conversion should not be applied to the portion of the vent system that is in the room of the appliance. Use only Co-Axial direct vent pipe (4" inner pipe, 6 5/8" outer pipe as listed on page 12) from the appliance to the retro-connector into converted flue system. Adhere to all specifications outlined in this manual regarding clearances to combustibles, vertical and horizontal vent length minimums and maximums, etc. Read all instructions in this manual and provided by vent manufacturer with kit carefully before starting the installation. Failure to follow the instructions may create a fire or other safety hazard, and will void the warranty. The following Vent System components may be safely used with this appliance.

Chimney DV Liner Kits

Model	Brand: SECURITY SECURE VENT / Description
SV4MCK	Masonry Chimney Conversion Kit - Vertical term. Cap, cap adapter, masonry cover, black adapter (to flex), 2 gear clamps
SV4CCK1	Factory Built Chimney Conversion Kit - for 6" I.D., 1" insulation.
SV4CCK2	Factory Built Chimney Conversion Kit - for 7" I.D., 1" insulation; 8" I.D., 1" insulation; 6" I.D., 2" insulation.
SV4CCK3	Factory Built Chimney Conversion Kit - for 10" I.D., 1" insulation; 7" I.D., 2" insulation; 8" I.D., 2" insulation.
Model	Brand: SIMPSON DURA-VENT / Description
934	Masonry Chimney Conversion Kit
931	Factory Built Chimney Conversion Kit A - for 6" I.D.;
932	Factory Built Chimney Conversion Kit B - for 6", 7" & 8" I.D.
933	Factory Built Chimney Conversion Kit C - for 7" & 8" I.D.

Table 7

Select Venting System - Horizontal Or Vertical

The following sections describe vertical (roof) and horizontal (exterior wall) vent applications. Refer to the section relating to your installation. A list of approved venting components is shown on page 11 & 12.

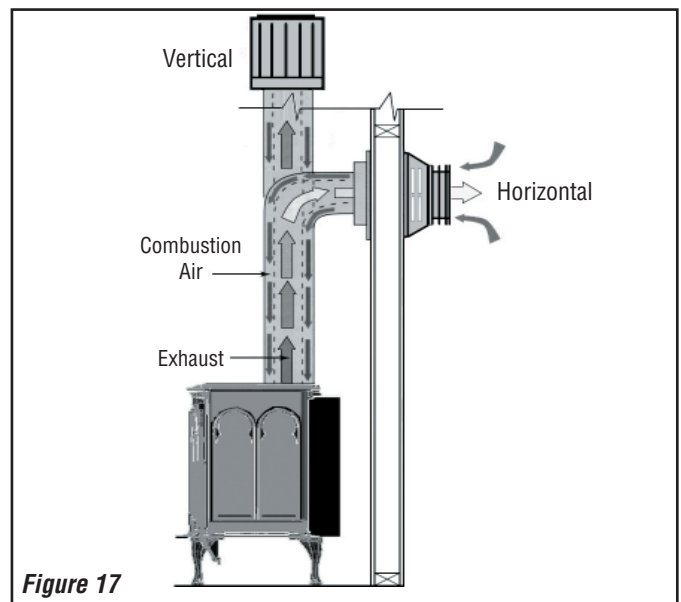

DIRECT VENT SYSTEM COMPONENTS

The following "Security Secure Vent™" or "Simpson Dura-Vent" brand Direct-Vent components may be safely used with these appliances.

IMPORTANT NOTE: Seal the first section of pipe to the stove collar using mill-pac black, high temperature sealant.

Model #	SECURITY SECURE-VENT - Description	Model #	SIMPSON DURA-VENT Description
N/A	N/A	970	Basic Horizontal Term. Kit (90 Deg. Black Elbow, Wall Thimble Cover, Horizontal Square Term. Cap)
N/A	N/A	971	Horizontal Term. Kit A (90 Deg. Black Elbow, Wall Thimble Cover, Horizontal Square Term. Cap, adj. 24 black pipe, 11-14 5/8 adj. black pipe)
SV4FK	Vertical Flat Roof Term. Kit (w/flashing, storm collar, vertical Term. Cap)	973	Vertical Termination Kit (990B, 940, 984)
SV4FAK	Vertical pitched Roof Kit, 1/12-7/12 (with adjustable roof flashing, storm collar, vertical termination cap)	978	Vertical Pitched Roof Kit, 0/12 6/12 (with adjustable flashing, storm collar, low profile term. Cap)
SV4FBK	Vertical pitched Roof Kit, 8/12-12/12 (with adjustable roof flashing, storm collar, vertical termination cap)	N/A	N/A
SV4L6	6 Pipe Length (Galvanized)	908	6 Pipe Length (Galvanized)
SV4LB6	6 Pipe Length (Black)	908B	6 Pipe Length (Black)
N/A	N/A	907B	9 Pipe Length (Black)
SV4L12	12 Pipe Length (Galvanized)	906	12 Pipe Length (Galvanized)
SV4LB12	12 Pipe Length (Black)	906B	12 Pipe Length (Black)
SV4L24	24 Pipe Length (Galvanized)	904	24 Pipe Length (Galvanized)
SV4LB24	24 Pipe Length (Black)	904B	24 Pipe Length (Black)
SV4L36	36 Pipe Length (Galvanized)	903	36 Pipe Length (Galvanized)
SV4LB36	36 Pipe Length (Black)	903B	36 Pipe Length (Black)
SV4L48	48 Pipe Length (Galvanized)	902	48 Pipe Length (Galvanized)
SV4LB48	48 Pipe Length (Black)	902B	48 Pipe Length (Black)
SV4LA	6 Adj. Pipe Length, (Galvanized)	908	6 Adj. Pipe Length, (Galvanized)
SV4LBA	6 Adj. Pipe Length (Black)	N/A	N/A
SV4LA12	12 Adj. Pipe Length, (Galvanized)	911	11 -14 5/8 Adj. Pipe Length (Galvanized)
SV4LBA12	12 Adj. Pipe Length, (Black)	911B	11 -14 5/8 Adj. Pipe Length (Black)
SV4E45	45 Deg. Elbow, Swivel (Galvanized)	945G	45 Deg. Elbow, Swivel (Galvanized)
SV4EB45	45 Deg. Elbow, Swivel (Black)	945BG	45 Deg. Elbow, Swivel (Black)
SV4E90	90 Deg. Elbow, Swivel (Galvanized)	990G	90 Deg. Elbow, Swivel (Galvanized)
SV4EB90	90 Deg. Elbow, Swivel (Black)	990BG	90 Deg. Elbow, Swivel (Black)
SV4E90	90 Deg. Elbow (Galvanized)	990	90 Deg. Elbow (Galvanized)
SV4EB90	90 Deg. Elbow (Black).	990B	90 Deg. Elbow (Black)
SV4CHC-1	Horizontal Standard Term. Cap	984	Horizontal Standard Term. Cap
N/A	N/A	991	Vertical High Wind Term. Cap
SV4CGV	Vertical Termination Cap	N/A	N/A
SV4STC36	Snorkel Termination Cap 36	981	Snorkel Termination Cap 36
SV4STC14	Snorkel Termination Cap 14	982	Snorkel Termination Cap 14
SV4VS	Vinyl Shield Protector	950	Vinyl Siding Standoff
SV4SF	Round Ceiling Support / Wall Thimble Cover	940	Round Ceiling Support / Wall Thimble Cover
SV4CSB	Cathedral Ceiling Support Box, decorative square	941	Cathedral Ceiling Support Box
SV4PF	Black Plate, Decorative, Square	N/A	N/A
SV4SU	Universal Support	942	Round Ceiling Support Box/Wall Thimble
SV4FC	Storm Collar	953	Storm Collar
SV4RSM	Wall Radiation Shield	N/A	N/A
SV4BF	Firestop	963	Firestop Spacer
SV4F	Flashing, Flat Roof (storm collar included)	N/A	N/A
SV4FA	Flashing, Adjustable roof 1/12-7/12 (storm collar included)	943	Flashing 0/12-6/12
SV4FB	Flashing, Adjustable 8/12-12/12 (storm collar included)	943S	Flashing 7/12-12/12
SV4BM	Wall Band (Strap)	988	Wall Strap

Note: Snorkel Caps: These are elongate vent termination caps, which incorporate the principles of natural draft into a horizontal installation. Two styles are common, 14" and 36" (Cap height). They enhance draft and relieve back-pressure by creating natural draft in the snorkel.

Table 8

Step 10. CONNECTING GAS LINE

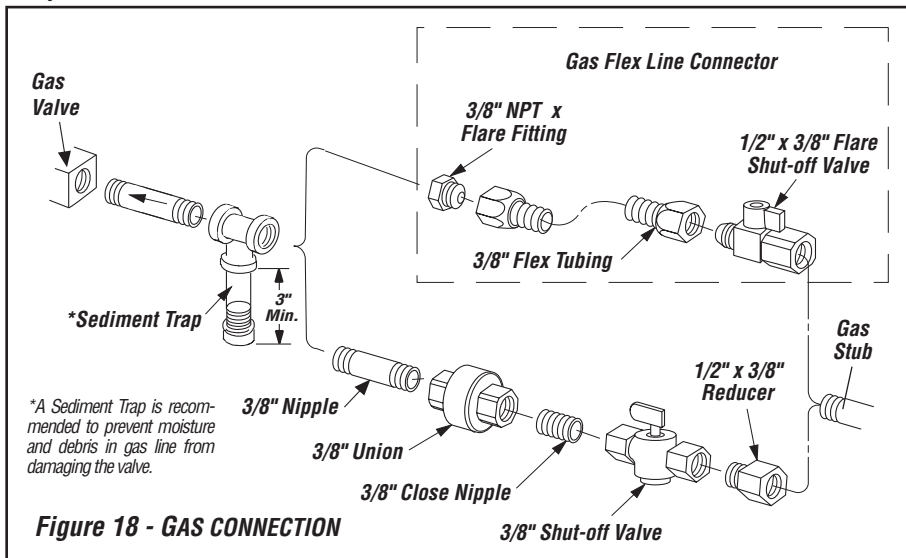

Make gas line connections. All codes require a shut-off valve mounted in the supply line. Figure 18 illustrates two methods for connecting the gas supply. The flex-line method is acceptable in the U.S., however, Canadian requirements vary depending on locality. Installation must be in compliance with local codes.

These appliances are equipped with a gas flex line for use (where permitted) in connecting the unit to the gas line. A gas flex line is provided to aid in attaching the direct vent appliance to the gas supply. The gas flex line can only be used where local codes permit. See Figure 18 for flex line description. The flex line is rated for both natural and propane gas. A manual shut off valve is also provided with the flex line. The gas control valve is located in the lower control compartment. To access the valve, open the lower access door. The millivolt control valve has a 3/8" (10 mm) NPT thread inlet port fitting.

AIR PURGING PROCEDURES MUST PERFORMED BY A QUALIFIED TECHNICIAN ONLY.

Purging Air from Supply Line

- Turn gas supply line valve off.
- Loosen setscrew at inlet pressure tap on upper right of control valve (see Figure 30).
- Turn gas supply line valve on.
- When gas flows, turn supply valve off.
- Close the inlet pressure tap.

Purging Air from Appliance

Purge air from appliance by holding gas control valve down in the pilot position until pilot will light (see Figure 19). **DO NOT LIGHT A MATCH IF YOU SMELL GAS.** Light a match then allow gas flow to pilot. If the Match "blows", there is air in the line (purge line). If the flame is straight and tall, there is no gas pressure.

When first lighting the appliance, it will take a few minutes for the line to purge air from the appliance. Once purging is complete,

the pilot and burner will light and operate as indicated in the instruction manual. Subsequent lightings of the appliance will not require such purging. Inspect the pilot flame (remove logs, if necessary, handling carefully).

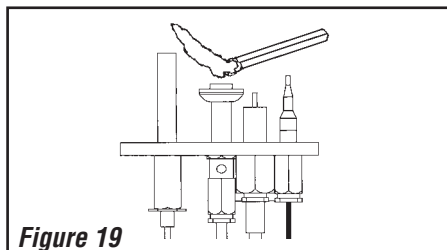

Step 11. INSTALLING LOGS AND GLOWING EMBERS

The packaged log set and bag of glowing embers are located within the firebox of the stove.

Installation Instructions:

WARNING: If logs are not installed according to the directions shown here, flame impingement and improper combustion could occur and result in soot and/or excessive production of carbon monoxide (CO), a colorless, odorless, toxic gas.

Carefully install the ember strip and seven-piece log set into the firebox as shown in these instructions. All logs should fit onto corresponding pins and/or log stoppers. This will ensure a proper flame and safe combustion.

- Carefully place the ember strip as shown in Figure 20. Ensure that it is pushed all the way back in position (toward the sub-floor front flange).

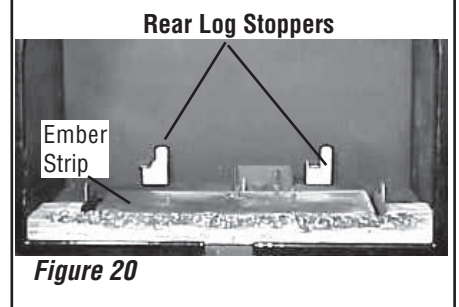

Note: If an optional Brick Liner Kit was purchased, install it now, per instructions provided in kit

- Place the largest log onto the rear log stoppers (see Figure 20). Ensure that the grooves on the bottom of the log aligns onto the corresponding places on the rear log stoppers. Push the log back so that it is against the back of the rear log stoppers (see Figure 21).

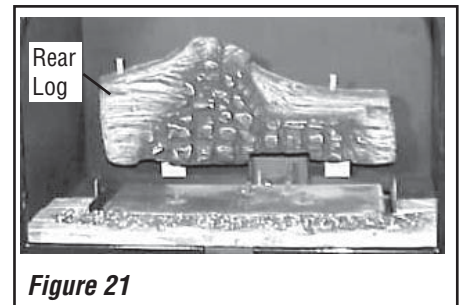

- Place the left front log onto the corresponding burner pin and sub-floor left tab as shown in Figure 22.

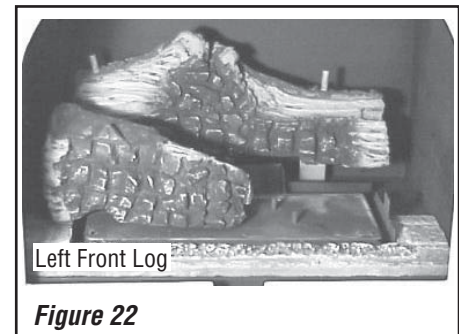

- Place the center log piece over the corresponding pins next to the front left log as shown in Figure 23.

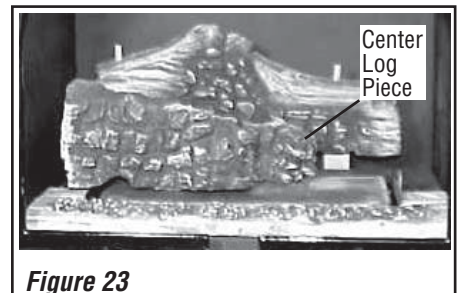

5. Install the right front log onto the corresponding burner pin and sub-floor right tab as shown in Figure 24.

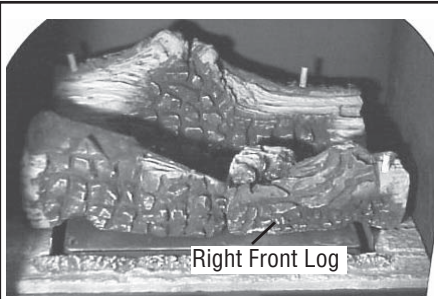

Figure 24

6. Install the left top twig onto the corresponding pin on the rear log and align it with the indentation on the front left log as shown in Figure 25.

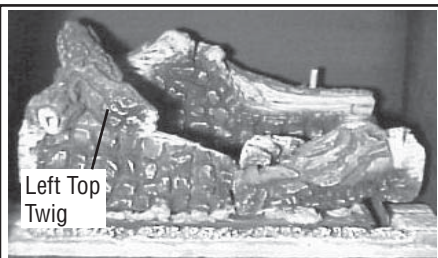

Figure 25

7. Install the center top twig onto the corresponding pin on the rear log and align it with the indentation on front left log as shown in Figure 26.

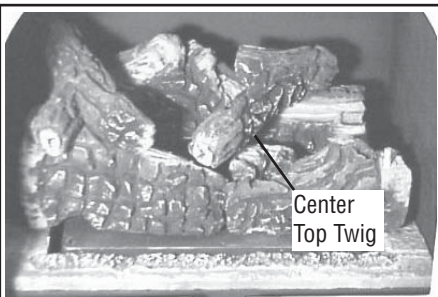

Figure 26

8. Install the front right twig onto the corresponding pin on the right front log. Align the twig with the indentation on the front right log as shown in Figure 27.

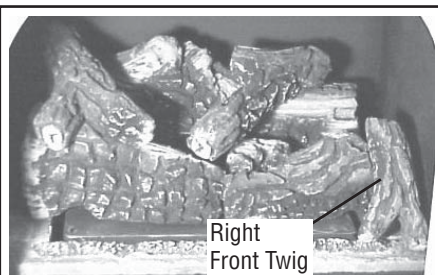

Figure 27

9. Place the glowing embers on the burner as shown in Figures 28 & 29.

One package of ember material has been included with this log set. You will not need to use the entire bag.

IMPORTANT: The quantity and placement of the ember material can affect stove performance therefore it is very important that it be placed as shown in Figures 28 & 29.

a. Unpackage and divide the fine ember material (mineral wool) into dime-sized fluffy pieces.

b. Distribute the pieces over the top of the front burner ports avoiding covering the slots (see Figure 29) and filling the area in front of the forward logs.

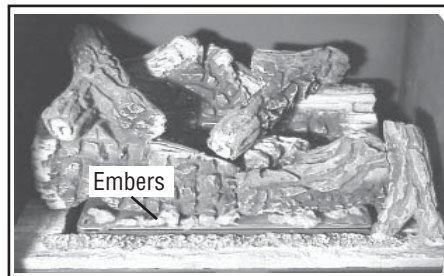
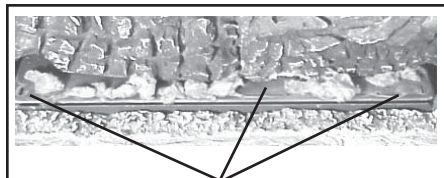

Figure 28



DO NOT PLACE EMBERS ON TOP OF THE BURNER SLOTS.

Figure 29

VERIFY THAT THE GAS LINE HAS BEEN PURGED OF AIR (SEE STEP 10).

Step 12. RE-INSTALL FRONT GLASS ENCLOSURE PANEL

(Reverse instructions on Step 4)

Retrieve the front glass enclosure panel. Visually inspect the gasket on the backside of the frame. Gasket surface must be clean, free of irregularities and seated firmly.

With the stove top off, position the glass front enclosure panel into the front opening with the gasket facing the relief door (reference Figure 8 & 9). Let the bottom of the door frame gently slide down, then hook the top flange of the glass frame over the top of the firebox frame.

Fasten the two latches located beneath the firebox floor to the glass frame vee-flange. Close both the latches securely.

Step 13. TEST ALL CONNECTIONS FOR LEAKS (FACTORY AND FIELD). Test For Gas Leaks

A. Mix a 50% dish soap, 50% water solution.

B. Light the appliance (refer to the lighting instructions provided in the Homeowner's Care and Operation Instructions).

C. Brush all joints and connections with the soapy water solution to check for leaks. If bubbles are formed, or gas odor is detected, turn the gas control knob to the "OFF" position and close the gas shut-off valve. Either tighten or refasten the leaking connection and retest as described above.

D. When the gas lines are tested and leak free, observe the individual tongues of flame on the burner. Make sure all ports are open and producing flame evenly across the burner. If any ports are blocked, or partially blocked, turn off unit, allow it to cool, then clean out the ports.

Turn on gas supply and test for gas leaks using a soapy water solution. Never use an open flame to check for leaks.

Step 14. CHECKING APPLIANCE OPERATION

With gas line installed run initial system checkout before closing up the front of the unit. Follow the pilot lighting instructions provided in the Homeowner's Care and Operation Instructions (or pull out the instruction label located in a holder on rear shield of stove). For piezo igniter location see Figure 30.

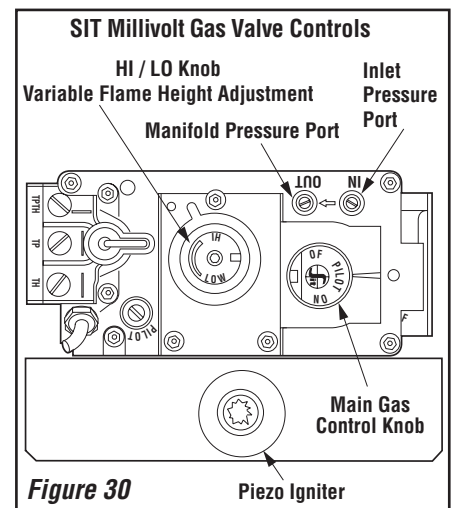

Figure 30

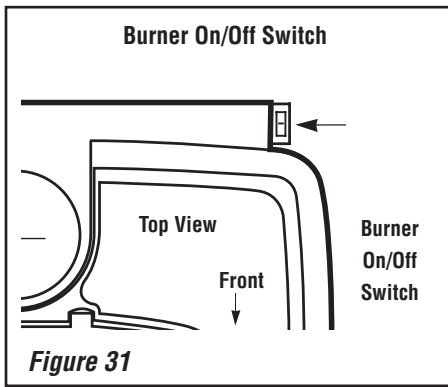

Figure 31

SIT Millivolt Appliance Checkout

The pilot flame should be steady, not lifting or floating. Flame should be blue in color with traces of orange at the outer edge. The top 3/8" (10 mm) at the pilot generator (thermopile) and the top 1/8" minimum (tip) of the quick drop out thermocouple should be engulfed in the pilot flame. The flame should project 1" (25 mm) beyond the hood at all three ports (Figure 32).

Replace logs if removed for pilot inspection.

To light the burner, rotate the gas valve control knob counterclockwise to the "ON" position then turn "ON" the ON/OFF rocker switch.

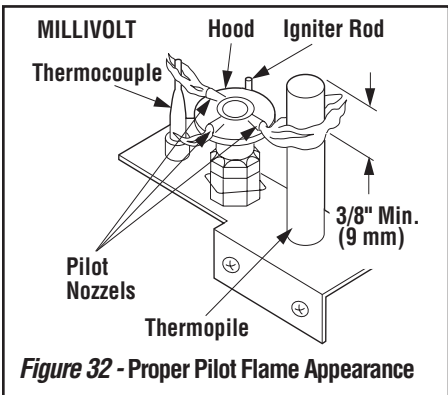

Figure 32 - Proper Pilot Flame Appearance

Step 15. BURNER ADJUSTMENTS

Flame Appearance and Sooting

Proper flame appearance is a matter of taste. Generally, most people prefer the warm glow of a yellow to orange flame.

Appliances operated with air shutter openings that are too large will exhibit flames that are blue and transparent. These weak, blue and transparent flames are termed anemic. If the air shutter opening is too small sooting may develop.



Figure 33 - Burner Flame Appearance

Sooting is indicated by black puffs developing at the tips of very long orange flames. Sooting results in black deposits forming on the logs, appliance inside surfaces and on exterior surfaces adjacent to the vent termination. Sooting is caused by incomplete combustion in the flames and lack of combustion air entering the air shutter opening. To achieve a warm yellow to orange flame that does not soot, the shutter opening must be adjusted between these two extremes.

No smoke or soot should be present. Reposition the logs if flames impinge on any of them. If the logs are properly positioned and sooting conditions exist, the air shutter opening on the main burner tube should be adjusted. Normally, the more offsets in the vent system, the greater the need for the air shutter to be opened further.

IMPORTANT: ENSURE THAT THE FRONT GLASS PANEL IS IN PLACE AND SEALED DURING ADJUSTMENT.

WARNING: AIR SHUTTER ADJUSTMENT SHOULD ONLY BE PERFORMED BY A QUALIFIED PROFESSIONAL SERVICE TECHNICIAN.

Burner Adjustment

CAUTION: THE ADJUSTMENT ROD AND NEARBY APPLIANCE SURFACES ARE HOT. EXERCISE CAUTION TO AVOID INJURY WHILE ADJUSTING FLAME APPEARANCE.

Initially, always position the air shutter to the factory setting as shown in Figure 34 (adjustment rod is located in the lower control area). This can be done by moving the adjustment rod up or down accordingly. Allow the burner to operate for at least 15 minutes. Observe the flame continuously. If it appears weak or sooty as previously described, adjust the air shutter to a more open position until the desired flame appearance is achieved.

NOTE: DIAGRAMS & ILLUSTRATIONS NOT TO SCALE.

The adjustment rod and associated adjustable air shutter is patented technology. Flame adjustments can be made quickly and accurately to taste without the need of disassembling the appliance and waiting for 30 minutes after each adjustment.

Burner Air Shutter Adjustment

Main Burner Factory Air Shutter Opening Setting - Inches (millimeter)		
Model	Natural Gas	Propane Gas
C11500DVF	5/16" (7.93 mm)	5/8" (15.9 mm)
C12500DVF	1/2" (12.7 mm)	5/8" (15.9 mm)

Figure 34

Air Shutter Adjustment Guidelines:

If the burner flame appearance differs greatly from what is shown on this page (see Figure 33), some adjustment from standard for the air shutter gap may be necessary (to compensate for variables in the installation and fuel such as, BTU value / composition, gas pressure, specific gravity of gas, altitude, etc.).

The following chart is provided to aid you in achieving the correct air shutter adjustment for your installation.

Air Shutter Adjustment Guidelines:		
Amount of Primary Air	Flame Color	Air Shutter Adjustment
If air shutter is closed too far →	Flame will be yellow →	Air shutter gap should be increased
If air shutter is open too far →	Flame will be blue →	Air shutter gap should be decreased

Table 10

When satisfied that the appliance operates properly, proceed to finish the installation. Leave the control knob in the ON position and the on/off switch in the OFF position.

Step 16. INSTALL STOVE TOP, TRIVET AND ASH LIP

A. Place the cast iron top into position on the stove top (See Figure 35). Place the trivet into the recess on the cast iron top (See Figure 35).

CAUTION: THE CAST IRON STOVE TOP IS VERY HEAVY AND MAY REQUIRE A MINIMUM OF TWO PEOPLE TO LIFT; ONE PERSON ON EACH SIDE (THE C11500 SERIES CAST TOP WEIGHS ~20 POUNDS AND THE C12500 SERIES CAST TOP WEIGHS ~40 POUNDS).

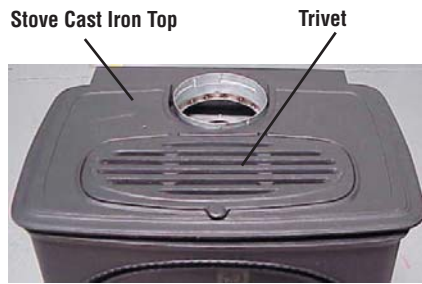
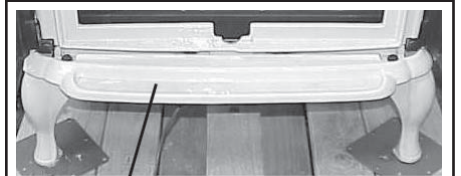

Figure 35

B. Locate the *ash lip* from packaging (Step 2). Remove the 2 bolts from the tapped holes in the ash lip. Align the ash lip below the firebox as shown in Figure 36 (the tapped holes in ash lip should align with corresponding slots below firebox). Reinstall the 2 bolts that were removed from the ash lip (finger tight only. If a tool is used, be careful not to overtighten).



Ash Lip

Figure 36



MODEL NO. CI1500DVF Series

MANUFACTURED AT: Burlington, WA

FOR USE WITH NATURAL GAS.	EQUIPE POUR GAZ NATUREL
ALTITUDE	0-4500 FT (0-1370 M)
MIN. GAS SUPPLY PRESS ("WC)	
PRESS MIN. D'ALIMENTATION ("CE)	4.5"
MANIFOLD PRESSURE ("WC)	
PRESSION CE TUBULURE ("CE)	3.5"
MANUFACTURER'S RECOMMENDED ORIFICE SIZE	
DIMENSION DE L'INJECTEUR RECOMMANDE PAR	#37
MANUFACTURIER (DMS)	
MAX INPUT (BTUH)	
ENTRÉE MAX (BTUH)	28,000
MIN INPUT (BTUH)	
ENTRÉE MIN (BTUH)	17,500

ELECTRICAL RATING/EXIGENCES ELECTRIQUES:	-UNIT/APPAREIL: MILLIVOLT
OPTIONAL FAN/SOUFFLEUR OPTIONAL <input checked="" type="checkbox"/>	1 ph
	60 HZ
	120 VOLTS
	LESS THAN 5 AMPS

MINIMUM CLEARANCES TO	SIDEWALLS FLOOR	2" 0"
	CEILING OR ALCOVE HEIGHT	62"
	BACK/CORNER 45°	4"
COMBUSTIBLE	VENT SURFACES: TOP	3"
	SIDES	1"
MATERIAL	BOTTOM	1"

	ALCOVE MAXIMUM DEPTH	48"
DEGAGEMENT	MUR ADJACENTS PLANCHER	50.8mm 0mm
MINIMUM DE	PLAFOND OU HAUTEUR D'ALCÔVE EN ARRIÈRE ET COIN 45 ANGLE	1574.8mm 101.6mm
MATERIAUX	SURFACES D'AERATION: DESSUS	76.2mm
	COTES	25.4mm
COMBUSTIBLES	BAS	25.4mm

	PROFONDEUR D'ALCÔVE MAXIMALE	1219.2mm
--	------------------------------	----------

DIRECT VENT GAS STOVE / APPAREIL A GAZ AVEC EVACUATION DIRECTE
 VENTED GAS STOVE HEATER - NOT FOR USE WITH SOLID FUEL.
 FOYER DE CHAUFFAGE AU GAZ A EVACUATION - NE DOIT PAS ETRE UTILISE AVEC UN COMBUSTIBLE SOLIDE.

FOR USE WITH GLASS DOOR CERTIFIED WITH THE APPLIANCE ONLY.
 N'UTILISER SEULEMENT QUE LA PORTE DE VERRE CERTIFIE AVEC L'APPAREIL.
 "CAUTION: Do not operate the appliance with glass removed, cracked or broken. Replacement of panel should be done by a licensed or qualified service person."
 "This appliance is equipped at the factory for use with natural gas only. Units using propane must be field converted using the LP conversion kit, P/N LB-102158A"

FINAL INSPECTION BY:

ANSI Z21.88-2002
 CSA 2.33-2002
 CAN/CGA-2.17-M91



OMNI-Test Laboratories, Inc.

VENTED GAS STOVE HEATERS
 FOYER DE CHAUFFAGE AU GAZ A EVACUATION P/N 9-1452A

SERIAL NUMBER/NOMBRE DE SERIE

XXXXXX XXXXX



XXXXXXXXXXXXXXXXXXXX

P/N 9-1452A



MODEL NO. CI2500DVF Series

MANUFACTURED AT: Burlington, WA

FOR USE WITH NATURAL GAS.	EQUIPE POUR GAZ NATUREL
ALTITUDE	0-4500 FT (0-1370 M)
MIN. GAS SUPPLY PRESS ("WC)	
PRESS MIN. D'ALIMENTATION ("CE)	4.5"
MANIFOLD PRESSURE ("WC)	
PRESSION CE TUBULURE ("CE)	3.5"
MANUFACTURER'S RECOMMENDED ORIFICE SIZE	
DIMENSION DE L'INJECTEUR RECOMMANDE PAR	.121
MANUFACTURIER (DMS)	
MAX INPUT (BTUH)	
ENTRÉE MAX (BTUH)	38,500
MIN INPUT (BTUH)	
ENTRÉE MIN (BTUH)	25,500

ELECTRICAL RATING/EXIGENCES ELECTRIQUES:	-UNIT/APPAREIL: MILLIVOLT
OPTIONAL FAN/SOUFFLEUR OPTIONAL <input checked="" type="checkbox"/>	1 ph
	60 HZ
	120 VOLTS
	LESS THAN 5 AMPS

MINIMUM CLEARANCES TO	SIDEWALLS FLOOR	2" 0"
	CEILING OR ALCOVE HEIGHT	62"
	BACK/CORNER 45°	4"
COMBUSTIBLE	VENT SURFACES: TOP	3"
	SIDES	1"
MATERIAL	BOTTOM	1"

	ALCOVE MAXIMUM DEPTH	48"
DEGAGEMENT	MUR ADJACENTS PLANCHER	50.8mm 0mm
MINIMUM DE	PLAFOND OU HAUTEUR D'ALCÔVE EN ARRIÈRE ET COIN 45 ANGLE	1574.8mm 101.6mm
MATERIAUX	SURFACES D'AERATION: DESSUS	76.2mm
	COTES	25.4mm
COMBUSTIBLES	BAS	25.4mm

	PROFONDEUR D'ALCÔVE MAXIMALE	1219.2mm
--	------------------------------	----------

DIRECT VENT GAS STOVE / APPAREIL A GAZ AVEC EVACUATION DIRECTE
 VENTED GAS STOVE HEATER - NOT FOR USE WITH SOLID FUEL.
 FOYER DE CHAUFFAGE AU GAZ A EVACUATION - NE DOIT PAS ETRE UTILISE AVEC UN COMBUSTIBLE SOLIDE.

FOR USE WITH GLASS DOOR CERTIFIED WITH THE APPLIANCE ONLY.
 N'UTILISER SEULEMENT QUE LA PORTE DE VERRE CERTIFIE AVEC L'APPAREIL.
 "CAUTION: Do not operate the appliance with glass removed, cracked or broken. Replacement of panel should be done by a licensed or qualified service person."
 "This appliance is equipped at the factory for use with natural gas only. Units using propane must be field converted using the LP conversion kit, P/N LB-102158B"

FINAL INSPECTION BY:

ANSI Z21.88-2002
 CSA 2.33-2002
 CAN/CGA-2.17-M91



OMNI-Test Laboratories, Inc.

VENTED GAS STOVE HEATERS
 FOYER DE CHAUFFAGE AU GAZ A EVACUATION P/N 9-1452F

SERIAL NUMBER/NOMBRE DE SERIE

XXXXXX XXXXX



XXXXXXXXXXXXXXXXXXXX

P/N 9-1452F

Lennox reserves the right to make changes at any time, without notice, in design, materials, specifications, prices and also to discontinue colors, styles and products. Consult your local distributor for fireplace code information.

Printed in U.S.A. © 2003 Lennox Hearth Products
P/N 775,147M REV. C 11/2004

LENNOX[®]
HEARTH PRODUCTS

110 West Taft Avenue • Orange, CA 92865