

This Owner's Manual is provided and hosted by [Appliance Factory Parts](http://www.appliancefactoryparts.com).



# Breadman TR555LC Owner's Manual

[Shop genuine replacement parts for Breadman  
TR555LC](#)



[Find Your Breadman Bread Machine Parts - Select From 41 Models](#)

----- Manual continues below -----

### IMPORTANT NOTICE

If any parts are missing or defective,  
**DO NOT** return this product.  
Please call our Consumer Service Department for assistance.

**800-233-9054** Monday - Friday 8am - 5pm CST

Thank You



If after reading this instruction  
booklet you still have questions about using the  
Breadman® Automatic Bread Machine,  
please write or call:

Salton, Inc.  
P.O. Box 7366  
Columbia, MO 65205-7366  
1-800-233-9054  
Monday - Friday 8am - 5pm CST

For more information on Salton, Inc. products, E-mail us at:

breadman@saltonusa.com  
OR, visit our website:  
<http://www.breadman.com>  
or [www.eSalton.com](http://www.eSalton.com)

TR555LC  
Printed in China

P/N 61089#1  
©2002 Salton, Inc.

**Breadman®**

## INSTRUCTION MANUAL



COOL TOUCH  
AUTOMATIC BREAD BAKER



## TABLE OF CONTENTS

Important Safeguards .....	1
Additional Important Safeguards .....	2
Polarized Plug .....	2
Your Breadman® .....	3
Control Panel .....	4
Using the Breadman® .....	5 - 7
Baking Cycles .....	8
Making Dough and Baking Bread .....	9 - 12
Crust Control .....	12
Using the Delay Bake Timer .....	13-14
Super Rapid Breads, As Easy As 1-2-3! .....	15
Super Rapid Bread Recipes .....	16 - 19
Jam Cycle Instructions .....	20
Using the Batter Breads™ Cycle .....	21
Dough Cycle Instructions .....	22
Bake Only Cycle Instructions .....	22
Cleaning Instructions .....	23
Basic and Rapid Bread Recipes .....	24
Basic Rapid Bread Recipe .....	25
Trouble Shooting .....	26 - 28
Guarantee/Warranty .....	Inside Back Cover

## LIMITED ONE YEAR WARRANTY

**Warranty:** This Breadman® product is warranted by Salton, Inc. to be free from defects in materials or workmanship for a period of (1) year from the original purchase date. This product warranty covers only the original consumer purchaser of the product.

**Warranty Coverage:** This warranty is void if the product has been damaged by accident in shipment, unreasonable use, misuse, neglect, improper service, commercial use, repairs by unauthorized personnel, normal wear and tear, improper assembly, installation or maintenance abuse or other causes not arising out of defects in materials or workmanship. This warranty is effective only if the product is purchased and operated in the USA, and does not extend to any units which have been used in violation of written instructions furnished with the product or to units which have been altered or modified or to damage to products or parts thereof which have had the serial number removed, altered, defaced or rendered illegible. Wear and tear for Bread Pans and Paddles is not considered a manufacturer's defect.

**Implied Warranties:** ANY IMPLIED WARRANTIES WHICH THE PURCHASER MAY HAVE ARE LIMITED IN DURATION TO ONE (1) YEAR FROM THE DATE OF PURCHASE. Some states do not allow limitations on how long an implied warranty lasts, so the above limitation may not apply to you.

**Warranty Performance:** During the above one-year warranty period, a product with a defect will be either repaired or replaced with a reconditioned comparable model (at our option) when the product is returned to the Repair Center, or the purchase price refunded. The repaired or replacement product will be in warranty for the balance of the one-year warranty period and an additional one-month period. No charge will be made for such repair or replacement.

**Service and Repair:** Should the appliance malfunction, you should first call toll-free 1 (800) 233-9054 between the hours of 9:00 am and 5:00 pm Central Standard Time and ask for CONSUMER SERVICE stating that you are a consumer with a problem. Please refer to model number TR555LC when you call.

**In-Warranty Service (USA):** For an appliance covered under the warranty period, no charge is made for service or postage. Call for return authorization 1 (800) 233-9054.

**Out-of-Warranty Service:** A flat rate charge by model is made for out-of-warranty service. Include \$15.00 (U.S.) for return shipping and handling. We will notify you by mail of the amount of the charge for service and require you to pay in advance for the repair or replacement.

**For Products Purchased in the USA, but Used in Canada:** You may return the product insured, packaged with sufficient protection, and postage and insurance prepaid to the USA address listed below. Please note that all customs duty / brokerage fees, if any, must be paid by you and we will require you to pay the cost of customs duty / brokerage fees to us in advance of our performing any service.

**Risk During Shipment:** We cannot assume responsibility for loss or damage during incoming shipment. For your protection, carefully package the product for shipment and insure it with the carrier. Be sure to enclose the following items with your appliance: any accessories related to your problem, your full return address and daytime phone number, a note describing the problem you experienced, a copy of your sales receipt or other proof of purchase to determine warranty status. C.O.D. shipments cannot be accepted.

<b>To return the appliance, ship to:</b>	<b>To contact us, please write to, call, or email:</b>
ATTN: Repair Center	Salton, Inc.
Salton, Inc.	P.O. Box 7366
708 South Missouri Street	Columbia, MO 65205-7366
Macon, MO 63552	1 (800) 233-9054
	E-mail: Salton@Saltonusa.com

**Limitation of Remedies:** No representative or person is authorized to assume for Salton, Inc. any other liability in connection with the sale of our products. There shall be no claims for defects or failure of performance or product failure under any theory of tort, contract or commercial law including, but not limited to negligence, gross negligence, strict liability, breach of warranty and breach of contract. Repair, replacement or refund shall be the sole remedy of the purchaser under this warranty, and in no event shall Salton be liable for any incidental or consequential damages, losses or expenses. Some states do not allow the exclusion or limitation of incidental or consequential damages, so the above limitation or exclusion may not apply to you.

**Legal Rights:** This warranty gives you specific legal rights, and you may also have other rights which vary from state to state.

For more information on Salton products: visit our website: [www.breadman.com](http://www.breadman.com), or email us at: [breadman@saltonusa.com](mailto:breadman@saltonusa.com) or [esalton.com](mailto:esalton.com)

©2002 Salton, Inc. All rights reserved.  
Printed in China

P/N 61089#1  
12/02



## TROUBLE SHOOTING (CONTINUED)

Symptom	Possible Solutions
The bread didn't rise at all	Make sure yeast is not left out. Also check the date code on the yeast and that it is always the last ingredient put into the Pan. Make sure the yeast doesn't come into contact with salt or any liquid ingredients.
The dough looks like batter, or the dough ball is still sticky, not smooth and round	During the Kneading process, add 1 tablespoon of flour at a time, letting it mix in well. For most breads, your dough ball should become round, smooth, not sticky to the touch, and should bounce back when you press it with your finger.
The dough ball is lumpy or too dry	During the Kneading process, add 1 tablespoon of water at a time, letting it mix in well.
The bread caved in	Make sure liquids are measured correctly. Next time, reduce your liquids by 2 tablespoons. If you're using fruits or vegetables, make sure they are well drained.
:END: displays	The Baking Cycle is completed.



## IMPORTANT SAFEGUARDS

WHEN USING THE BREADMAN® COOL TOUCH AUTOMATIC BREAD BAKER, BASIC SAFETY PRECAUTIONS SHOULD ALWAYS BE FOLLOWED, PARTICULARLY THE FOLLOWING:

1. **READ ALL INSTRUCTIONS BEFORE USE.**
2. Do not touch hot surfaces. Use handles or knobs. Always use oven mitts when handling hot materials and allow metal parts to cool before cleaning.
3. Unplug this product from wall outlet when not in use and before cleaning. Allow to cool thoroughly before putting on or taking off parts.
4. Do not immerse appliance in water or any other liquid.
5. Close supervision is always necessary when this or any appliance is used by or near children.
6. Do not allow anything to rest on the power cord. Do not plug in cord where persons may walk or trip on it.
7. Do not operate this or any appliance with a frayed or damaged cord, or after the appliance malfunctions, or has been damaged in any manner. Return the appliance to Salton, Inc. for examination and repair.
8. Avoid contact with any moving parts.
9. Do not use attachments not recommended by Breadman® Products; they may damage the appliance or cause injury.
10. This appliance is intended for household use only. Do not use outdoors or for commercial purposes.
11. Do not let the cord hang over the edge of a table or counter, or touch hot surfaces. Do not place on an unsteady or cloth-covered surface.
12. Do not place the appliance near a hot gas or electric burner, in a heated oven.
13. Keep the unit at least 2 inches away from walls or any other objects when using it.
14. To disconnect, grip the plug and pull the plug from the wall outlet. Never pull on the cord.

### SAVE THESE INSTRUCTIONS

**NOTE:**

- A. A short power-supply cord is provided to reduce the risk of becoming entangled in or tripping over a longer cord.
- B. Extension cords are available and may be used, but special care must be exercised in use.
- C. If an extension cord is used:
  - (1) the marked electrical rating of the extension cord should be at least as great as the electrical rating of the appliance, and
  - (2) the cord should be arranged so that it will not drape over the counter top or tabletop where it can be pulled on by children or tripped over unintentionally.

**CAUTION:** During use, the internal parts of the Breadman® Ultimate™ and the area around the Steam Vent are **HOT**. **Keep out of reach of children to avoid possible injury.**





## ADDITIONAL IMPORTANT SAFEGUARDS

**WARNING:** This appliance generates heat and escaping steam during use. Use proper precautions to prevent risk of burns, fires, or other injury to persons or damage to property.

1. Always use oven mitts when handling hot materials and allow metal parts to cool before cleaning.
2. Do not place the appliance on an unsteady or cloth-covered surface.
3. Keep the appliance at least 2 inches away from walls or any other objects when using it.

**CAUTION:** During use, the internal parts of the Breadman® and the area around the Steam Vent and Viewing Window are **HOT. Keep out of reach of children to avoid possible injury.**

### POLARIZED PLUG

This appliance has a polarized plug (one blade is wider than the other). To reduce the risk of electric shock, this plug is intended to fit into a polarized outlet only one way. If the plug does not fit fully in the outlet, reverse the plug. If it still does not fit, contact a qualified electrician. Do not attempt to modify the plug in any way.

### ELECTRIC POWER

If the electrical circuit is overloaded with other appliances, your appliance may not operate properly. It should be operated on a separate electrical circuit from other appliances.



## TROUBLE SHOOTING (CONTINUED)

Symptom	Possible Solutions
The Bread Machine does not bake the bread	The Dough program was selected. To bake the bread, choose the appropriate program for baking bread.
Bread has an offensive odor	Check to be sure you added the correct amount of yeast. Measure carefully — too much yeast will cause an unpleasant odor and may cause the loaf to rise too high. Be sure to use only fresh ingredients.
Baked bread is soggy or the bread's surface is sticky	Remove the bread from the Bread Pan as soon as it is done baking. Leaving it in the Pan allows condensation to collect on the sides touching the Pan. Also be sure to cool the loaf on a wire rack; cooling it on a countertop causes the side next to the counter to become soggy.
The Kneading Paddle was stuck in the bread	Make sure the Kneading Paddle is mounted properly before adding ingredients to the Bread Pan and baking. Sometimes denser or crustier loaves of bread may pull the Kneading Paddle out with them when you remove the loaves after baking. When this happens, use a non-metal utensil and gently remove the blade from the bottom of the loaf.
The bread rose too high	Make sure not to add too much yeast, water or flour. Too much of any of these may cause the loaf to rise more than it should.
The bread didn't rise enough	Did you add enough yeast, water or sweetener? Make sure to add ingredients in the proper order: liquids, dry ingredients, yeast. Make sure yeast doesn't get wet until the Breadman® mixes the ingredients together. <b>NOTE: Typically, bread made with whole grain flours will not rise as high as bread made with refined flours. Make sure you are using bread flour.</b>





## TROUBLE SHOOTING

Symptom	Possible Solutions
Display Window shows nothing	Make sure the machine is plugged in. If nothing appears in the Display Window, unplug and plug in again.
START Button doesn't start the machine	Make sure the machine is plugged in. If nothing appears in the Display Window, press <b>SELECT</b> to choose your Baking Cycle. (You must select a Baking Cycle before pressing <b>START</b> .) If the baking area is too hot, the Breadman® will not start because of an automatic safety feature. Remove the Bread Pan with your ingredients, and wait until the Breadman® cools down — about 20 minutes — before starting a new loaf.
Can't set the Timer	If you selected either the Rapid Bake or Dough Cycle, you should not use the Timer. This is because the ingredients should be processed immediately for these cycles.
After starting, the Display Window flashes "--H"	If the Bread Machine is too hot, it will not start because of an automatic safety feature. Remove the Pan and let the Bread Machine cool down until "--H" disappears and the selection reappears. You may then start the cycle.
The Bread Machine doesn't mix the ingredients	On preheating the colon (:) in the Time Display flashes and the Kneading Paddle will not move. There is a 4 - 5 min. rest period on some of the cycles in which there will be no movement in the Pan for 4 - 5 min. If the Kneading Paddle does not operate after this period of time, check to see if the Kneading Paddle is engaged in the machine correctly.
The Breadman® stops	This happens if you press the <b>STOP</b> Button, if you unplug the machine, or if there is a power outage. In each case, the Breadman® can't be restarted for this Cycle. Discard the contents of the Bread Pan and start again with new ingredients.



## YOUR BREADMAN®

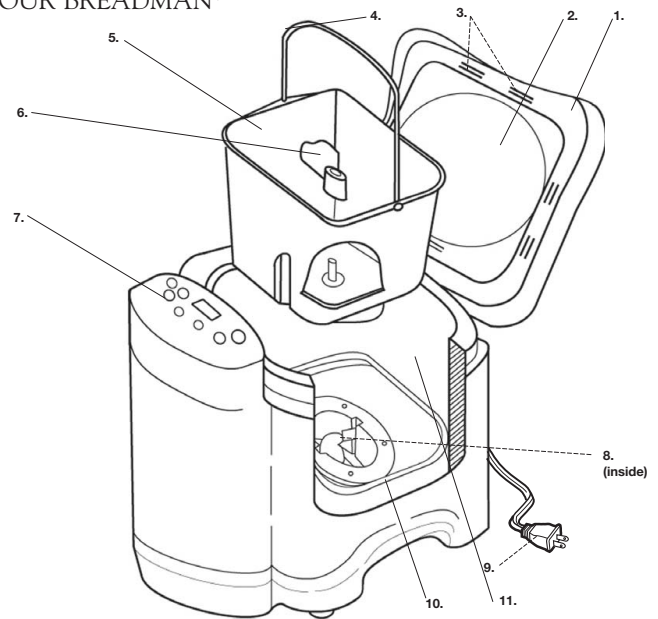

- |                                |                         |
|--------------------------------|-------------------------|
| 1. Removable Lid (P/N 21789)   | 8. Drive Shaft (inside) |
| 2. Viewing Window              | 9. Power Supply Cord    |
| 3. Steam Vents                 | 10. Heating Element     |
| 4. Bread Pan Handle            | 11. Oven Chamber        |
| 5. Bread Pan (P/N 20101)       |                         |
| 6. Kneading Paddle (P/N 20102) |                         |
| 7. Control Panel               |                         |



## CONTROL PANEL

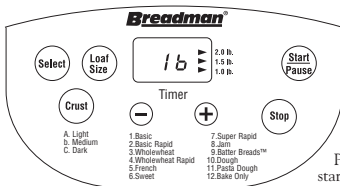

### A. Display Window

Shows your selection and Timer setting.

### B. Standard Options

Select from these bread choices:

1. Basic
2. Basic Rapid
3. Wholewheat
4. Wholewheat Rapid
5. French
6. Sweet
7. Super Rapid
8. Jam
9. Batter Breads™
10. Dough
11. Pasta Dough
12. Bake Only

### C. Select

Press the **SELECT** Button to select the Baking Cycle you want. Each time the **SELECT** Button is pressed, a new selection will appear in the Display Window. (The selections will be displayed in the order listed above.)

### D. Loaf Size

Press **LOAF SIZE** Button to select a 1.0 lb, 1.5 lb. or 2.0 lb. loaf size.

The LCD Display will show:

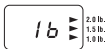

### E. Crust

Choose from Light, Medium or Dark crust.

### F. Start/Pause

Press the **START/PAUSE** Button to start the Baking Cycle.

The **PAUSE** function can be activated only after the machine has started a baking program. Press again and hold this Button for about 1 second, the Baking Cycle will be paused and the time in LCD will be flashing. Press this Button again, the Baking Cycle will resume.

**NOTE:** After 10 minutes, the Baking Cycle will resume automatically.

### G. Delay Bake Timer

Use **(+)** or **(-)** **TIMER** Buttons to add or subtract time displayed in the Display Window, from 10 minutes to 13 hours.

**(+)** Each time you press this arrow, the Timer advances 10 minutes.

**(-)** Each time you press this arrow, the Timer is set back 10 minutes.

**NOTE:** Holding the arrow down in place will either fast forward **(+)**, or fast reverse **(-)** the time.

### H. Stop

Press this Button for a full second to turn OFF the power, to reset the Baking Cycle or Timer setting, or to STOP Baking.

**NOTE:** When the **(+)** or **(-)** **TIMER**, **SELECT**, **CRUST**, **LOAF SIZE**, **START/PAUSE** or **STOP** Buttons are pressed, you will hear a beep. This lets you know that your selection was made.

4

## BASIC RAPID BREAD RECIPE

### IMPORTANT

Weather conditions such as temperature, altitude or accuracy in measuring can effect the outcome of a loaf.

We recommend that you use warm water (115°F - 120°F / 45°C - 50°C) for best results on the Deluxe Rapid Cycle. We also recommend using a Quick Rise or Rapid Rise Yeast. This yeast will speed the rising action.

### Basic White

	1.5 lb.	2 lb.
Warm Water	1 cup + 2 tablespoons	1-1/4 cup + 2 tablespoons
Oil	4 teaspoons	2 tablespoons
Sugar	1 tablespoon	1-1/2 tablespoons
Salt	1-1/2 teaspoons	1-1/2 teaspoons
Dry Milk	1 tablespoon + 2 teaspoons	2 tablespoons
Bread Flour	3 cups	4 cups
Rapid Rise Yeast	1 tablespoon + 1 teaspoon	2 tablespoons + 1 teaspoon
<b>PROGRAM</b>	<b>2</b>	<b>2</b>

25



## BASIC BREAD RECIPE

### Rich Country Buttermilk Bread

	1 lb.	1.5 lb.	2 lb.
Non Fat Buttermilk	3/4 cup	1 cup + 2 tablespoons	1-1/2 cups
Unbleached Bread Flour	2-1/2 cups	3-1/4 cups	4-1/4 cups
Sea Salt	1 teaspoon	1-1/2 teaspoons	2 teaspoons
Butter or Canola Oil	2 tablespoons	3 tablespoons	1/4 cup
Honey	2 tablespoons	3 tablespoons	1/4 cup
Baking Soda	1/4 teaspoons	1/4 teaspoons	1/2 teaspoons
Active Dry Yeast	1-1/4 teaspoons	1-1/2 teaspoons	1-3/4 teaspoons
<b>PROGRAM</b>	<b>1</b>	<b>1</b>	<b>1</b>

#### To prepare Rich Country Buttermilk Bread:

- Always use fresh ingredients.
- Always put liquids in the Bread Pan first, yeast last.
- Always allow the bread to cool thoroughly prior to slicing.

Beginning with the buttermilk, add the ingredients to the Pan in the order listed. Following the operating instructions in this book, then select the size of loaf and press **START**.

#### Rapid Version:

- Substitute Active Dry Yeast with Rapid Rise or Quick Rise Yeast and use the following measurements:

	1 lb.	1.5 lb.	2 lb.
Rapid Rise Yeast	2-1/2 teaspoons	1 tablespoon	3-1/2 teaspoons
<b>PROGRAM</b>	<b>2</b>	<b>2</b>	<b>2</b>

## USING THE BREADMAN®



Before using the Breadman® for the first time, carefully read all of the instructions included in this manual.

With your new Breadman® Cool Touch Bread Baker:

- You can use commonly available pre-packaged bread mixes. Follow the instructions on the package.
- You can bake a loaf of bread from scratch. See the *Recipe & Menu Planner* included with your Breadman® Cool Touch Bread Baker for lots of tasty options.
- There are also many bread machine cookbooks available at bookstores nationwide.
- You can make dough for rolls or shaped loaves you'll bake in your own oven.
- Use the Dough Cycle to do the mixing and kneading for you, then shape, proof, and bake it in the Breadman® Cool Touch Oven, or in a conventional oven.
- You can make Batter Breads™ jam, and pasta dough too!
- You can activate **PAUSE**, remove the dough for shaping, filling, braiding and more.
- You can activate **PAUSE** to score the top of your loaf for a rustic style bread or make a decorative crust with rolled oats, poppy seeds, etc.

#### Inserting and Removing the Bread Pan

- Insert the Bread Pan into the Oven Chamber. Press down until it locks into place.
- Remember to attach your Kneading Paddle **FIRST**, then add the ingredients **BEFORE** inserting the Bread Pan into the Oven Chamber.
- When you remove the Bread Pan after baking, **BE SURE TO WEAR OVEN MITTS** to prevent burning. Hold the Handle and lift the Bread Pan up and out of the Bread Baker.
- Remove the loaf by turning the Bread Pan upside down and shaking gently, then check to see that the Kneading Paddle is removed from the loaf. If it is stuck in your bread, use a non-metal utensil to gently remove it, taking care not to scratch the Kneading Paddle.



## USING THE BREADMAN® (CONTINUED)

### Operating Tips

- Use oven mitts when working with bread or any part of the Breadman® that is hot from baking.
- Wipe off crumbs and clean the Breadman®, as needed, after baking.
- Unplug the Breadman® Cool Touch Baker when you are not using it.
- **It is normal for the Viewing Window to collect moisture during the Rise Cycle.** As your food bakes, the moisture soon will evaporate so you can watch your bread's baking progress.

### Caution

- Do not touch the Viewing Window during use. The Viewing Window gets very hot.
- **Don't open the Lid during Baking.** This causes baked products to bake improperly.
- **Don't unplug the Breadman® during Kneading or Baking.** This will stop the operation.
- You have Instant Recall™ Power Failure Back-Up. If the electricity in your home goes out, the Breadman® Cool Touch Baker's memory stores the active program for up to 15 minutes.

### Power Failure Back-Up

**NOTE: Power Failure Back-Up does not cover surges.**

*If you experience frequent surges, please use a surge protector.*

- If your power is out for longer than 60 minutes, and if you are using any dairy products, perishables or meats in your bread, for health, sanitary and other considerations, you should discard the contents of the recipe and start again with new fresh ingredients.



## CLEANING INSTRUCTIONS

The Bread Pan and Kneading Paddle have non-stick surfaces that make cleaning easy.

1. After baking each loaf of bread, unplug the Breadman® and discard any crumbs.
2. Before cleaning, make sure the Breadman® is completely cooled. Remove the Bread Pan from the Oven and the Kneading Paddle from the Bread Pan. Then, as needed, wash the Bread Pan and Kneading Paddle inside and out with warm, soapy water. Avoid scratching the non-stick surfaces. **DO NOT PUT THE BREAD PAN IN A DISHWASHER.**

If the Kneading Paddle is stuck to the Drive Shaft, pour warm water in the Pan to loosen it.  
**DO NOT USE EXCESSIVE FORCE.**

3. Wipe the inside of the Lid and Oven with a damp cloth or sponge. If any residue has scorched on the Heating Plate or elsewhere, wipe with a non-abrasive scrubbing pad and wipe clean.
4. Do not use vinegar, bleach, or harsh chemicals to clean the Breadman®.
5. Do not soak the Bread Pan for a long period of time — this could interfere with the free working of the Drive Shaft.
6. Be sure the machine is completely cooled before storing.
7. The inner casing contains the heating element and drive base. Therefore, when cleaning, NEVER pour water, solvents or cleaning solutions into this area.

### Caution

To avoid electric shock, unplug the Breadman® before cleaning!





## DOUGH CYCLE INSTRUCTIONS

- The Dough Cycle (10) is used to make a variety of bread types (with the exception of Pasta).
- After the end of the first rise, remove the dough, shape the dough and bake it in a conventional oven.
- Dough Cycle takes 1 hour 20 minutes.
- The Breadman® will signal 5 minutes before it is finished Kneading, indicating when any additional ingredients such as dried fruits, nuts or herbs should be added.

### Pasta Dough

- The Pasta Dough Cycle (11) simplifies Pasta Dough preparation. When completed, roll out with a rolling pin and prepare your favorite pastas to your liking.
- The Pasta Dough Cycle takes 14 minutes.

## BAKE ONLY CYCLE INSTRUCTIONS

Use the Bake Only Cycle (12) if you have frozen or stored bread dough, Batter Breads™ batter or a bread batter and would now like to bake it.

- Always thaw frozen dough completely before baking.
- This Cycle will bake the ingredients only for the time that you specify, from 5 minutes to 2 hours.
- **You do not need to insert the Kneading Paddle for this Cycle. It bakes only.**

**NOTE:** The Baking Cycle can be programmed in 1 minute increments.



## USING THE BREADMAN® (CONTINUED)

### CAUTION

- To protect young children, keep the Breadman® out of their reach when you're not there to supervise — especially during the Kneading and Baking Cycles.
- Use the Breadman® on a flat, hard surface. Don't place it near a flame or heat, or on a soft surface (such as a carpet). Avoid placing it where it may tip over during use. Dropping the Breadman® could cause it to malfunction.
- To avoid burns, stay clear of the Steam Vent during Kneading and Baking. Also, do not touch the Viewing Window — it gets very hot.
- **ALWAYS HANDLE THE HOT BREAD PAN OR BAKING RACK WITH A POT HOLDER OR OVEN MITT.** After baking, wait for the Breadman® to cool down before touching or cleaning the Bread Pan, Baking Rack, or internals of the Breadman® without oven mitts.
- Never use metal utensils with the Breadman®. These can scratch the non-stick surface of the Bread Pan.
- Avoid electric shock by unplugging the machine before using a damp cloth or sponge to wipe the interior of the Oven.
- Never use the Bread Pan on a gas or electric cooktop, on an open flame, or in a microwave oven.
- Avoid covering the Steam Vent during Kneading and Baking Cycles. This could cause the Breadman® to warp or discolor.
- Always make sure the Kneading Paddle is removed from the bread prior to slicing.





## KNEADING AND BAKING CYCLES

- The Crust Control feature lets you choose Light, Medium or Dark crusts for most bread varieties, including Basic, French, Sweet, and Wholewheat.
- The French Cycle is for breads with crisper crusts, especially those that are lowest in fats, such as French and Italian breads.
- Make delicious non-yeast Batter Breads™
- 59 Minute Start-to-Finish Super Rapid Bread.
- The Basic Rapid and the Wholewheat Rapid Cycles are faster than the Basic Cycles and produce a more developed flavor than the Super Rapid Cycle.
- The Jam Cycle makes your favorite jams.
- 2 Dough-Only Cycles: Dough and Pasta Dough.
- Bake Only is used to bake filled, rolled or specialty loaves from previously frozen dough.
- 13 Hour Delay Bake Timer.
- The Fruit & Nut Add-In Beeper will sound at the end of the second Kneading Cycle in the Basic: Light, Medium and Dark, Sweet Cycles, as well as the Wholewheat and French Cycles.
- If bread is not removed immediately after baking and the STOP Button is not pressed, a controlled 60 minute Keep Warm function will begin for each selection (except Dough). This will help reduce condensation between loaf and Bread Pan, it is best to remove bread as soon as possible after completion of the baking phase.

Fruit & Nut  
Add-In Beeper

60 Minute  
Keep Warm



## USING THE BATTER BREADS™ CYCLE

The Breadman® Batter Breads™ Cycle (9) is for non-yeast breads, such as banana bread, pumpkin bread or Batter Breads™. Batter Breads usually call for quick-acting leavening agents such as baking powder or baking soda.

The Breadman® will mix all of the ingredients and bake a cake-like bread in 1 hour 40 minutes.

**NOTE: These breads tend not to rise as high as yeast breads.**

### For Best Results

Basic Batter Bread™ recipes can be used as well as pre-packaged cake mixes.

When baking Batter Breads™ from scratch, please note the following:

- Baking cakes such as pound cake or angel food cake or any cake that requires long beating of eggs or egg whites or other ingredients are not recommended in the Breadman®.
- If a recipe calls for a 9" x 5" cake pan, it will not have any problem fitting into the Baking Pan. On the same note, if a recipe is written to form two layers, the recipe can be cut in half to fit into the Baking Pan.
- **Batter Breads™ in which all ingredients can be mixed together at one time are prime recipes for the Breadman®.**

### Operating Instructions

- Measure ingredients in the recipe and add to the Baking Pan. (Make sure the Kneading Paddle is in position.)
- Insert Baking Pan into the Breadman® and close the Lid.
- Press **SELECT** to select the Batter Breads™ Cycle.
- Press **START/STOP** Button to begin Cycle.
- The baking process will finish in 1 hour 40 minutes.

### CAUTION:

- **BE SURE TO WEAR OVEN MITTS AS THE UNIT WILL BE VERY HOT!**
- Turn onto a baking rack and let the Batter Bread™ cool completely before slicing or decorating.

### PLEASE NOTE:

*The Delay Bake Timer can not be used for the Batter Breads™ Cycle.*





## JAM CYCLE INSTRUCTIONS

The Jam Cycle (8) is very similar to the Batter Breads™ Cycle. Just add your ingredients and the Breadman® will do the rest.

### For Best Results

- Do not reduce sugar or use sugar substitutes. The exact amounts of sugar, fruit, and pectin are necessary for a good set.
- Use only ripe fruit (not overripe or underripe) for best flavor.
- Do not puree fruit. Crush with a potato masher or food processor. Jam should have bits of fruit in it.
- Recipes should not exceed 3-1/2 cups.
- Be sure to measure fruit after it has been crushed, *not before*.
- Remove stems, seeds, or pits from fruit before crushing.

### Operating Instructions

- With Kneading Paddle in position, add the ingredients called for in your recipe.
- Insert Baking Pan into the Breadman.®
- Close Lid.
- Press **SELECT** Button to select the Jam Cycle.
- Press **START/STOP** Button to begin.
- **The Breadman® will pre-heat for 20 minutes before anything begins to mix.** After this time, the ingredients will be mixed and heated for 90 minutes. The entire Cycle takes 1 hour and 10 minutes to complete.
- The Breadman® will beep when the Cycle is complete.
- Press **START/STOP** and remove the Baking Pan from the machine. **MAKE SURE TO WEAR OVEN MITTS AS THE PAN WILL BE EXTREMELY HOT!**
- Pour the hot jam into a refrigerator/freezer-safe container, leaving at least 1/2" of space at the top. Cover tightly.
- Jam will thicken upon cooling and storage.

### PLEASE NOTE:

*The Delay Bake Timer can not be used for the Jam Cycle.*



## MAKING DOUGH AND BAKING BREAD

Always use the freshest ingredients available. By carefully following the simple recipes that come with the Breadman®, you will be able to bake delicious bread every time.

### STEP 1

Open the Lid and remove the Bread Pan.

Lift the Bread Pan straight up and out of the machine.

### STEP 2

Position the Kneading Paddle on the Drive Shaft.

Match the flat side of the Drive Shaft to the flat part of the hole in the Kneading Paddle. Make sure the Paddle is secure.

### STEP 3

Place the ingredients into the Bread Pan.

For best results, add all liquid ingredients first. Then, add all dry ingredients EXCEPT yeast.

**ALWAYS ADD YEAST LAST.**

**NOTE:** *If your recipe contains salt, please add salt with liquid ingredients, keeping it away from the yeast. Salt may activate the yeast prematurely.*

**\*For Batter Breads™ Jam and Dough Cycles, the order of ingredients is not important.**

### STEP 4

Make a small indentation on top of the dry ingredients (not so deep it reaches the wet layer) and add the yeast to the indentation.

This order of adding ingredients is important, especially when using the Delay Bake Timer, because it keeps the yeast away from the wet ingredients until the kneading process begins. (Liquid ingredients will prematurely activate the yeast.)

### STEP 5

Insert the Bread Pan into the Oven Chamber. Press down until it snaps into place.

Close the Lid and plug in the Breadman®. "0:00" will appear in the Display Window.





**STEP 6**

Press the **SELECT** Button to choose the Cycle you want.  
Each time the **SELECT** Button is pressed, it will beep and the number next to the Cycle on the Control Panel will correspond to the number in the Display Window.

For instance, to choose the Basic Rapid Cycle, press the **SELECT** Button twice. The Display Window will read "2b" — the number of the Cycle chosen.

Remember, the Super Rapid Cycle (7) produces a loaf of bread in 59 minutes — and, the Basic Rapid Cycles (2 and 4) are faster than the Basic Cycles (1, 3, 5, 6).

1. Basic
2. Basic Rapid
3. Wholewheat
4. Wholewheat Rapid
5. French
6. Sweet
7. Super Rapid
8. Jam
9. Batter Breads™
10. Dough
11. Pasta Dough
12. Bake Only

**NOTE:** The Basic or Rapid setting is available only for Basic, French, Sweet or Wholewheat settings.

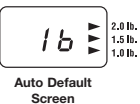

**IMPORTANT:** If the **SELECT** Button is not pressed, and **START** is activated, the Breadman® Auto Default Screen will appear and the unit will reset to auto default programming of:

1 (Basic) b (medium crust) 2 lb. loaf

**STEP 7**

Press the **CRUST CONTROL** Button to select what color you would like your crust to be when the loaf is finished baking. "A," (Light) "b," (Medium) or "C" (Dark) will appear in the Display Window

**NOTE:** CRUST CONTROL cannot be activated for the following Cycles:

7. Super Rapid
8. Jam
9. Batter Breads™
10. Dough
11. Pasta Dough
12. Bake Only

**STEP 8**

Press **LOAF SIZE** Button for the size you prefer. Each time this Button is pressed, the Indicator Light will appear next to either the 2.0 lb., 1.5 lb. or 1.0 lb., at the right side of the Display Window to verify which size is selected. If this Button is not pressed, the Bread Baker will automatically choose 2.0 lb. loaf size.

**NOTE:** When using the Dough, Batter Breads™ or Jam Cycles, steps 7 and 8 are not needed.



**SUPER RAPID BREAD RECIPES (CONTINUED)**

**Honey Granola Bread**

	2 lb.
Water (100°-115°F/43°-46°C)	1-1/2 cups + 1 tablespoon
Oil	6 tablespoons
Honey	2-1/2 tablespoons
Salt	2 teaspoons
Dry Milk	3 tablespoons
Bread Flour	4-1/4 cups
Granola Cereal	1 cup
Super Rapid Type Yeast	6-3/4 teaspoons
<b>PROGRAM</b>	<b>7</b>

**Cinnamon Raisin Bread**

	1 lb.	2 lb.
Water (100°-115°F/43°-46°C)	1 cup + 1 tablespoon	1-1/4 cups + 1 tablespoon
Oil	1 tablespoon	7 teaspoons
Brown Sugar	2-1/2 tablespoons	3-1/2 tablespoons
Salt	1 teaspoon	1-1/2 teaspoons
Dry Milk	1 tablespoon	1-1/2 tablespoons
Bread Flour	2-1/4 cups	3-1/2 cups
Cinnamon	3/4 teaspoons	1 teaspoon
Raisins	1/3 cup	1/2 cup
Walnuts	1/3 cup	1/2 cup
Super Rapid Type Yeast	4-1/2 teaspoons	6-3/4 teaspoons
<b>PROGRAM</b>	<b>7</b>	<b>7</b>





SUPER RAPID BREAD RECIPES (CONTINUED)

**White Wheat Bread**

	1 lb.	2 lb.
Water (100°-115°F/43°-46°C)	3/4 cup + 3 tablespoons	1-1/2 cups + 3 tablespoons
Oil	1 tablespoon	3 tablespoons
Sugar	3 tablespoons	1/4 cup
Salt	1 teaspoon	2 teaspoons
Dry Milk	1 tablespoon	2 tablespoons
Bread Flour	1-3/4 cups	3-1/2 cups
Wholewheat Flour	1/2 cup	1/2 cup
Super Rapid Type Yeast	4-1/2 teaspoons	6 teaspoons
<b>PROGRAM</b>	<b>7</b>	<b>7</b>

**French Bread**

	1 lb.	2 lb.
Water (100°-115°F/43°-46°C)	3/4 cup + 3 tablespoons	1-1/2 cups + 2 tablespoons
Oil	1 teaspoon	1-1/2 teaspoons
Sugar	2-1/2 teaspoons	1-1/2 tablespoons
Salt	3/4 teaspoon	1-1/2 teaspoons
Bread Flour	2-1/4 cups	4-1/3 cups
Super Rapid Type Yeast	3-1/2 teaspoons	6 teaspoons
<b>PROGRAM</b>	<b>7</b>	<b>7</b>

**Italian Bread**

	1 lb.	2 lb.
Water (100°-115°F/43°-46°C)	1 cup + 1 tablespoon	1-1/2 cups + 1 tablespoon
Oil	4 teaspoons	2 tablespoons
Sugar	2 tablespoons	1/4 cup
Salt	1 teaspoon	2 teaspoons
Dry Milk	1 tablespoon	2 tablespoons
Dried Italian Seasoning	1-1/2 teaspoons	1 tablespoon
Bread Flour	2-1/4 cup	4 cups
Super Rapid Type Yeast	4-1/2 teaspoons	6-3/4 teaspoons
<b>PROGRAM</b>	<b>7</b>	<b>7</b>

**STEP 9**

Press **START/PAUSE** Button to begin the Kneading Cycle.

The time remaining will begin to count down in the Display Window. The Breadman® will begin mixing the ingredients for a minute. Then, it will begin the kneading process. During this process, the yeast will activate and normally the Viewing Window may begin to fog. (This will clear eventually so you can view the loaf's progress).

For the Basic, French, Sweet and Wholewheat Cycles, the Breadman® will beep 3 times, before the end of the Kneading Cycle, at which time you may add any fruits or nuts, herbs, meat, garlic, etc.

**NOTE: The Add-In Beeper will not sound during the Super Rapid, Jam, Batter Breads™ or Bake Only Cycles.**

**STEP 10**

When your bread is finished baking the Breadman® will beep 3 times and "0:00" will appear in the Display Window. Press the **STOP** Button and open the Lid.

Put on oven mitts and remove the Bread Pan very carefully as it will be very hot.

Remember that the Bread Pan and your loaf are both very hot! Be careful not to place either on a tablecloth, plastic surface, or other heat-sensitive surface which may scorch or melt.

If the bread is not removed immediately after baking and if the **STOP** Button is not pressed, the Keep Warm controlled temperature reduction will begin and then the machine will automatically shut off after 60 minutes. While this will help prevent the bread from becoming soggy, **for best results**, remove bread immediately after the baking cycle is complete. By pressing the **STOP** Button, the screen will go back to the Select mode.

**NOTE:** Keep Warm does not apply to the following Cycles:

- 8. Jam
- 9. Batter Breads™
- 10. Dough
- 11. Pasta Dough
- 12. Bake Only



### STEP 11

Wearing oven mitts, remove the loaf from the Bread Pan onto an aerated cooling rack.

Invert the Bread Pan a few inches above the countertop and cooling rack, and gently shake. Your loaf should slide easily out of the non-stick Bread Pan onto the rack. The cooling rack will prevent the loaf from retaining too much moisture.

If necessary, remove the Kneading Paddle from the loaf.

Sometimes the Kneading Paddle will stick in a loaf of bread. If it does, use a plastic or non-metal utensil to gently remove it, taking care not to scratch the Kneading Paddle. This is a common procedure with bread makers.

The bread should cool for 30 minutes before it is sliced.

When you are done using the Breadman® Cool Touch Bread Baker, be sure to unplug it.

#### Crust Control

- The **CRUST CONTROL** Button is used to select the baking temperature from the following options:
  - Light:** Use to bake Batter Breads™ or the like at a relatively low temperature. The baking time is changeable with the **(+)** or **(-)** **TIMER** Buttons within the range of 10 minutes to 4 hours.
  - Medium:** This mode should be selected when baking a bread made with a Basic, Sweet or Wholewheat dough. The baking time is changeable with the **(+)** or **(-)** **TIMER** Buttons within the range of 10 minutes to 4 hours.
  - Dark:** This mode should be selected when baking a bread made with the French setting. The baking time is changeable with the **(+)** or **(-)** **TIMER** Buttons within the range of 10 minutes to 4 hours.

12



## SUPER RAPID BREAD RECIPES (CONTINUED)

#### Method

- Remove the Bread Pan from the Bread Maker. Attach the Kneading Paddle onto the Shaft. Have all ingredients ready. Make sure all ingredients, except water, are at room temperature.
- Use a liquid measuring cup to measure the water 100°-115°F / 43°-46°C and pour into the Bread Pan.
- Use a measuring spoon to measure the oil and add to the Bread Pan.
- Use a measuring spoon to measure the sugar, salt and dry milk; level off with the straight edge of a knife and add to the Bread Pan.
- Lightly spoon bread flour into a dry measuring cup, level off with the straight edge of a knife and add to the Bread Pan.
- Carefully measure **Quick-Rise™** or **RapidRise™** yeast with a measuring spoon; level off with the straight edge of a knife and add to the Bread Pan.
- Place the Bread Pan into the Bread Maker. Close the Lid and plug in the Breadman®.
- Press the **SELECT** Button until the Display Window reads "7". Press **START**.
- When the Beeper sounds, the bread has finished baking.
- Use oven mitts to carefully remove the Bread Pan.

**CAUTION: The Oven Cavity, Bread Pan, Kneading Paddle and bread will be very hot. Use oven mitts.**

- Turn Bread Pan upside down and shake several times to release the bread. Do not use metal utensils inside the Bread Pan or Bread Maker. Remove the Kneading Paddle and allow loaf to cool standing upright on wire rack approximately 20 minutes before cutting.
- When the bread has completely cooled, approximately 2 hours, store in an air-tight container.
- Unplug unit before cleaning. Do not immerse the Bread Pan in water. See Cleaning Instructions.

17





## SUPER RAPID BREAD RECIPES

We suggest starting your Super Rapid bread baking with this White Bread Recipe. To successfully bake loaf of bread using the Super Rapid Cycle:

- Refer to Super Rapid Cycle Hints for measuring information.
- Follow each step carefully.
- Water temperature must be 100°-115°F / 43°-46°C.
- Quick-Rise™ or RapidRise™ Bread Machine yeast must be used.

### White Bread

	1 lb.	1-1.5 lb.	2 lb.
Water	1 cup	1-1/4 cups	1-1/2 cups + 3 tablespoons
Temperature: (100°-115°F / 43°-46°C)			
Oil	4 teaspoons	2-1/2 tablespoons	1/4 cup
Sugar	4 teaspoons	2 tablespoons	3 tablespoons
Salt	1 teaspoon	1-1/2 teaspoons	2 teaspoons
Dry Milk	1 tablespoon	1-1/2 tablespoons	2 tablespoons
Bread Flour	2-1/4 cups	3 cups	4 cups
Super Rapid Type Yeast	3-1/2 teaspoons	5-1/2 teaspoons	6-3/4 teaspoons
<b>PROGRAM</b>	<b>7</b>	<b>7</b>	<b>7</b>



## USING THE DELAY BAKE TIMER

### 13 Hour Delay Bake Timer

#### Caution

You can preset your Breadman® to delay baking from 10 minutes to 13 hours in advance.

**NOTE: Do not use the Delay Bake Timer if your recipe includes eggs, fresh milk or other perishable ingredients that may spoil.**

To preset your Breadman®, follow these steps:

1. Add the ingredients as usual, taking care not to let the yeast and liquid ingredients contact one another.
2. Close the Breadman® Lid and plug it in.
3. Select the Baking Cycle you want. The time needed for the selected Baking Cycle appears in the Display Window.
4. Press the **TIMER (+)** Button once for each 10 minutes you want to add to the clock. Press the **TIMER (-)** Button to decrease the time in 10 minute intervals. The amount of time set is shown in the Display Window.

**NOTE: To fast forward time, continually press down the (+) or (-) TIMER Buttons.**

- Simply count the number of hours between start and finish. For example, if it is now 6 :00 PM and you want a loaf of bread ready at 7:00 AM breakfast, press the **(+) TIMER** Button until the display reads 13:00. (This is the number of hours between 6:00PM (present time) and 7:00AM (finished time).
5. Press **START** Button to begin the Timer. The colon (:) in the Display Window begins to flash, letting you know the Timer is started. The remaining amount of time left to finish is shown as the Timer counts down to completion. When the Display Window indicates 0:00, baking is completed.

6. If you make an error after you have activated the Timer and want to start over, press and hold the **STOP** Button. The unit will reset to auto default programming of :

1 (Basic) b (medium crust) 2 lb. loaf  
and if you wish, you may begin again.

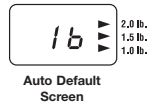

Auto Default Screen





## USING THE DELAY BAKE TIMER (CONTINUED)

### For Best Results

- Take care to measure ingredients accurately, using a good set of measuring cups and spoons, or a good scale. Make sure to level all dry ingredients as you measure them. Inaccurate measuring could cause unexpected results in your loaf of bread.
- In particular, be precise in measuring the water.
- Use fresh ingredients.
  - Since moisture is an enemy to flour, be sure to store your flour in an airtight container.
  - To keep your yeast active, store it in an airtight container in your refrigerator.
- **Speaking of fresh** — when using the Timer, we recommend setting it for as short a time as possible. Because ingredients are partially combined in the Bread Pan, the dough may tend to deteriorate if left too many hours, especially on a warm or humid day.
- Keep the Lid closed during the Baking Cycle. Opening it causes uneven baking.
- After your bread has cooled completely, store it in a brown paper bag.



## SUPER RAPID BREADS, AS EASY AS 1-2-3!

The Super Rapid Cycle (7), with shorter Rise and Bake Cycles, is convenient for baking a hot, fresh loaf of bread in 59 minutes! The longer bread programs, with slower rise and bake times, will bake a taller, more developed loaf of bread.

1. Add ingredients to the Bread Pan in the order listed. Refer to Super Rapid Cycle Hints below for measuring information. Place the Bread Pan into the Bread Maker.
2. Close the Lid. Press the **SELECT** Button until the Display Window reads "7" indicating that Super Rapid Cycle has been chosen. Press **START**.
3. When finished baking, remove Bread Pan from the Bread Maker. **BE SURE TO WEAR OVEN MITTS** to prevent burning. Invert and gently shake to remove the loaf. Allow the loaf to cool standing upright on a wire rack before slicing.
4. Always use Bread or Bread Machine flour.

### Super Rapid Cycle Hints

- Water temperatures must be 100°-115°F / 43°-46°C.
- Larger amounts of **Quick-Rise™** or **RapidRise™** Bread Machine\* yeast must be used.
- The dough ball for the Super Rapid Cycle should be a very soft, sticky to the touch, loose ball with a smooth texture. Do not add extra flour.
- Check the dough ball, and if necessary, use a rubber spatula to push any flour or dough from the sides of the Bread Pan down into the dough ball.
- As a result of the increased temperatures during the rise and bake process, the loaf of bread produced from this program may have a dark, crisp crust with a split in the top of the loaf.

\*These are special yeasts widely available in major grocery stores specifically for super rapid bread.

