



P/N 506023-08 Rev. D 10/2012

This manual is one of a set of two supporting this product. Refer to P/N 506025-01 for Care and Operation Instructions.

Ce manuel est disponible en français, simplement en faire la demande. Numéro de la pièce 506023-08CF.

## INSTALLATION INSTRUCTIONS

### Direct Vent Symmetry™ Series

DAVE LENNOX  
*signature*  
COLLECTION

#### MODELS

SYM-35N  
SYM-35P

SYM-40N  
SYM-40P

SYM-45N  
SYM-45P

Tested &  
Listed By  Portland  
Oregon USA  
OMNI-Test Laboratories, Inc.

OTL Report No. 116-F-51-5

**INSTALLER:** Leave this manual with the appliance.  
**CONSUMER:** Retain this manual for future reference.  
**INSTALLATEUR :** Laissez cette notice avec l'appareil.  
**CONSOMMATEUR :** Conservez cette notice pour consultation ultérieure.

This appliance may be installed in an aftermarket permanently located, manufactured home (USA only) or mobile home, where not prohibited by local codes. This appliance is only for use with the type of gas indicated on the rating plate. This appliance is not convertible for use with other gases unless a certified kit is used.

## WARNING / AVERTISSEMENT / AVISO

- HOT GLASS WILL CAUSE BURNS.
- DO NOT TOUCH GLASS UNTIL COOLED.
- NEVER ALLOW CHILDREN TO TOUCH GLASS.



- UNE SURFACE VITRÉE CHAUDE PEUT CAUSER DES BRÛLURES.
- LAISSER REFROIDIR LA SURFACE VITRÉE AVANT D'Y TOUCHER.
- NE PERMETTEZ JAMAIS À UN ENFANT DE TOUCHER LA SURFACE VITRÉE.

- EL VIDRIO CALIENTE CAUSARÁ QUEMADURAS.
- USTED DEBE NUNCA TOCAR EL VIDRIO CALIENTE.
- LOS NIÑOS DEBEN NUNCA TOCAR EL VIDRIO.

**WARNING:** If the information in these instructions is not followed exactly, a fire or explosion may result, causing property damage, personal injury, or death.

- Do not store or use gasoline or other flammable vapors and liquids in the vicinity of this or any other appliance.
- **WHAT TO DO IF YOU SMELL GAS:**
  - Do not try to light any appliance.
  - Do not touch any electrical switch; do not use any phone in your building.
  - Immediately call your gas supplier from a neighbor's phone. Follow the gas supplier's instructions.
  - If you cannot reach your gas supplier, call the fire department.
- Installation and service must be performed by a qualified installer, service agency or the gas supplier.

**AVERTISSEMENT :** Assurez-vous de bien suivre les instructions données dans cette notice pour réduire au minimum le risque d'incendie ou d'explosion ou pour éviter tout dommage matériel, toute blessure ou la mort.

- Ne pas entreposer ni utiliser d'essence ni d'autres vapeurs ou liquides inflammables dans le voisinage de cet appareil ou de tout autre appareil.
- **QUE FAIRE SI VOUS SENTEZ UNE ODEUR DE GAZ :**
  - Ne pas tenter d'allumer d'appareil.
  - Ne touchez à aucun interrupteur. Ne pas vous servir des téléphones se trouvant dans le bâtiment où vous trouvez.
  - Appelez immédiatement votre fournisseur de gaz depuis un voisin. Suivez les instructions du fournisseur.
  - Si vous ne pouvez rejoindre le fournisseur de gaz, appelez le service des incendies.
- L'installation et l'entretien doivent être assurés par un installateur ou un service d'entretien qualifié ou par le fournisseur de gaz.

## TABLE OF CONTENTS

Packaging .....	Page 2
Introduction .....	Page 2
General Information .....	Page 2
Requirements for the	
Commonwealth of Massachusetts .....	Page 4
New York City Approval.....	Page 4
Cold Climate Insulation .....	Page 5
Manufactured Home Requirements ..	Page 5
Location .....	Page 5
Vent Termination Clearances .....	Page 6
Appliance and Vent Clearances .....	Page 8
Detailed Installation Steps.....	Page 9
Typical Installation Sequence .....	Page 9
Step 1. Framing.....	Page 9
Fireplace and Framing Specifications	Page 10
Step 2. Routing Gas Line .....	Page 11
Step 3. Install the Venting System .....	Page 12
Vertical Termination Systems.....	Page 13
Vent Section Length Chart .....	Page 13
Vertical Vent Tables and Figures.....	Page 16
Horizontal Termination System .....	Page 17
Horizontal Vent Tables and Figures ...	Page 20
Venting Using Flexible Vent Pipe.....	Page 23
Step 4. Field Wiring.....	Page 24
Remote Control System .....	Page 25
Step 5. Connecting Gas Line.....	Page 26
Step 6. Verifying Appliance Operation	Page 27
Step 7. Installing Logs .....	Page 27
Step 8. Remove/Install Glass Door .	Page 32
Step 9. Burner Adjustments.....	Page 32
Step 10. Hood Installation.....	Page 34
Finishing Requirements .....	Page 34
Step 11. Attaching Safety-in-	
Operation Warnings .....	Page 35
Installation Accessories .....	Page 36
Gas Conversion Kits.....	Page 38

**Please read and understand these instructions before beginning your installation.**



We recommend that our gas hearth products be installed and serviced by professionals who are certified in the U.S. by the National Fireplace Institute® (NFI) as NFI Gas Specialists.

## PACKAGING

The assembled vented gas fireplace heater is packaged with the following:

- 1 - The logs are packaged in foam located within the firebox.
- 2 - One plastic bag of glowing embers, vermiculite, volcanic stones are located on top of the log package.
- 3 - One plastic bag containing the literature package, which consists of the care and operations manual, installation instructions, warning labels and warranty. The bag is located within the firebox, above the log package.
- 4 - One vent restrictor, to be used as detailed on page 12.
- 5 - One hood (strapped to the top of the unit) and one control compartment cover, installed in the unit.
- 6 - One plastic bag with the remote control and receiver kit, located inside the firebox.

## INTRODUCTION

These appliances are designed to operate on natural or propane gas. An electronic intermittent pilot ignition system provides safe, efficient operation. External electrical power (110 vac) is recommended to operate these units. If the system operates on line voltage with 6V fan control module, four (4) "AA" batteries can be used as a backup in case of a power outage. The electronic appliance can be operated without a fan, solely with four (4) "AA" batteries.

These vented gas fireplace heaters are sealed combustion, air-circulating gas fireplaces designed for residential applications.

**Approved Vent Components** - These fireplaces are designed, tested and listed for operation and installation with, the following vent components only:

- **Secure Vent™** Direct-Vent System Components manufactured by Security Chimneys International,
- **Secure Flex™** Flexible Vent Components manufactured by Security Chimneys International and
- **Z-FLEX™** Model GA Venting Systems listed to UL1777 and ULCS635 manufactured by Flexmaster Canada Limited.

Use only the correct size venting (4-1/2" inner and 7-1/2" outer).

These approved vent system components are labeled for identification. DO NOT use any other manufacturer's vent components with these appliances.

## GENERAL INFORMATION

### **WARNING**

**Young children should be carefully supervised when they are in the same room as the appliance. Toddlers, young children and others may be susceptible to accidental contact burns. A physical barrier is recommended if there are at risk individuals in the house. To restrict access to a fireplace or stove, install an adjustable safety gate to keep toddlers, young children and other at risk individuals out of the room and away from hot surfaces.**

### **AVERTISSEMENT**

**Les jeunes enfants devraient être surveillés étroitement lorsqu'ils se trouvent dans la même pièce que l'appareil. Les tout petits, les jeunes enfants ou les adultes peuvent subir des brûlures s'ils viennent en contact avec la surface chaude. Il est recommandé d'installer une barrière physique si des personnes à risques habitent la maison. Pour empêcher l'accès à un foyer ou à un poêle, installez une barrière de sécurité; cette mesure empêchera les tout petits, les jeunes enfants et toute autre personne à risque d'avoir accès à la pièce et aux surfaces chaudes.**

*Children and adults should be alerted to the hazards of high surface temperature and should stay away to avoid burns or clothing ignition.*

*Les enfants et les adultes devraient être informés des dangers que posent les températures de surface élevées et se tenir à distance afin d'éviter des brûlures ou que leurs vêtements ne s'enflamment.*

**DO NOT ATTEMPT TO ALTER OR MODIFY THE CONSTRUCTION OF THE APPLIANCE OR ITS COMPONENTS. ANY MODIFICATION OR ALTERATION MAY VOID THE WARRANTY, CERTIFICATION AND LISTINGS OF THIS UNIT.**

**! WARNING**

Improper installation, adjustment, alteration, service or maintenance can cause injury or property damage. Refer to this manual. For assistance or additional information consult a qualified installer, service agency or the gas supplier.

**! WARNING**

Failure to comply with these installation instructions will result in an improperly installed and operating appliance, voiding its warranty. Any change to this appliance and/or its operating controls is dangerous.

**! WARNING**

Clothing or other flammable material should not be placed on or near the appliance.

**! AVERTISSEMENT**

On ne devrait pas placer de vêtements ni d'autres matières inflammables sur l'appareil ni à proximité.

**! WARNING**

Any safety screen or guard removed for servicing the appliance must be replaced prior to operating the appliance.

**! AVERTISSEMENT**

Tout écran ou protecteur retiré pour permettre l'entretien de l'appareil doit être remis en place avant de mettre l'appareil en marche.

*Note: Installation and repair should be done by a qualified service person. The appliance should be inspected before use and at least annually by a professional service person. More frequent cleaning may be required due to excessive lint from carpeting, bedding material, etcetera. It is imperative that control compartments, burners and circulating air passageways of the appliance be kept clean.*

*Remarque : L'installation et la réparation devrait être confiées à un technicien qualifié. L'appareil devrait faire l'objet d'une inspection par un technicien professionnel avant d'être utilisé et au moins une fois l'an par la suite. Des nettoyages plus fréquents peuvent être nécessaires si les tapis, la literie, et cetera produisent une quantité importante de poussière. Il est essentiel que les compartiments abritant les commandes, les brûleurs et les conduits de circulation d'air de l'appareil soient tenus propres.*

Do not use these appliances if any part has been under water. Immediately call a qualified, professional service technician to inspect the appliance and to replace any parts of the control system and any gas control which have been under water.

Ne pas utiliser cet appareil s'il a été plongé, même partiellement, dans l'eau. Appeler un technicien qualifié pour inspecter l'appareil et remplacer toute partie du système de commande et toute commande qui a été plongée dans l'eau.

**! WARNING**

Improper installation or use of this appliance can cause serious injury or death from fire, burns, explosions or carbon monoxide poisoning.

*Only trim kit(s) supplied by the manufacturer shall be used in the installation of this appliance.*

*Seules les trousse de garniture fournies par le fabricant doivent être utilisées pour l'installation de cet appareil.*

These appliances comply with National Safety Standards and are tested and listed by OMNI-Test Laboratories, Inc. (Report No. 116-F-51-5) to ANSI Z21.88 (in Canada, CSA-2.33), and CAN/CGA-2.17-M91 in both USA and Canada, as vented gas fireplace heaters.

Both millivolt and electronic versions of these appliances are listed by OMNI-Test Laboratories for installation in bedrooms and Manufactured Homes.

**Misc. Codes / Standards -**

The Installation must conform to local codes or, in the absence of local codes, with the *National Fuel Gas Code, ANSI Z223.1/NFPA 54 - latest edition* (In Canada, the current CAN/CSA-B149.1 installation code).

The appliance, when installed, must be electrically grounded and wired in accordance with local codes or, in the absence of local codes, with the *National Electrical Code, ANSI/NFPA 70 - latest edition*, or the *Canadian Electrical Code, CSA C22.1 - latest edition*.

Provide adequate clearances around air openings and adequate accessibility clearance for service and proper operation. Never obstruct the front or back openings of the appliance.

**These appliances are designed to operate on natural or propane gas only. The use of other fuels or combination of fuels will degrade the performance of this system and may be dangerous.**

These fireplaces are designed as supplemental heaters. Therefore, it is advisable to have an alternate primary heat source when installed in a dwelling. Refer to **Table 1** for efficiencies.

Models	Efficiencies %					
	Natural Gas			Propane		
	P4*	Steady State	AFUE **	P4*	Steady State	AFUE **
SYM-35	61.7	70.6	64.8	62.4	71.3	65.2
SYM-40	60.7	70.7	64.3	61.2	72.1	64.6
SYM-45	63.9	72.4	66.2	64.2	73.1	66.3

**Table 1**

\*Canadian Energuide Rating

\*\*Annual Fuel Utilization Efficiency (AFUE) is the recognized U.S. rating system for the total efficiency of heating products.

These electronic models come standard with a modulating gas valve; flame appearance and heat output can be controlled with the remote. The BTU Input for these appliances is shown in **Table 2**.

Models	Input (BTU/HR) (all models)	
	Input Rate (BTU / HR)	
	Natural Gas	Propane Gas
SYM-35	33,000 high 21,500 low	27,500 high 21,000 low
SYM-40	37,000 high 23,500 low	32,000 high 24,500 low
SYM-45	39,000 high 26,000 low	33,500 high 26,000 low

**Table 2**

## Gas Pressure - All Models

Tables 3 and 4 show the appliances' inlet and manifold gas pressure requirements:

Inlet Gas Supply Pressure (all models)		
Fuel #	Minimum	Maximum
Natural Gas	4.5" WC (1.12 kPa)	10.5" WC (2.61 kPa)
Propane	11.0" WC (2.74 kPa)	13.0" WC (3.23 kPa)

**Table 3**

Manifold Gas Supply Pressure (all models)		
Fuel #	Low	High
Natural Gas	(Lo) 1.6" WC (0.40 kPa)	(Hi) 3.5" WC (0.87 kPa)
Propane	(Lo) 6.3" WC (1.57 kPa)	(Hi) 10.0" WC (2.49 kPa)

**Table 4**

Test gauge connections are provided on the front of the gas control valve (identified IN for the inlet and OUT for the manifold side). The control valves have a 3/8" (10mm) NPT thread inlet and outlet side of the valve (see **Figure 1**).

Propane tanks are at pressures that will cause damage to valve components. Verify that the tanks have step down regulators to reduce the pressure to safe levels.

These appliances must be isolated from the gas supply piping system (by closing their individual manual shut-off valve) during any pressure testing of the gas supply piping system at test pressures equal to or **less than** 1/2 psig (3.5 kPa).

These appliances and their individual shut-off valves must be disconnected from the gas supply piping system during any pressure testing of that system at pressures **greater than** 1/2 psig (3.5 kPa).

These appliances must not be connected to a chimney or flue serving a separate solid fuel burning appliance.

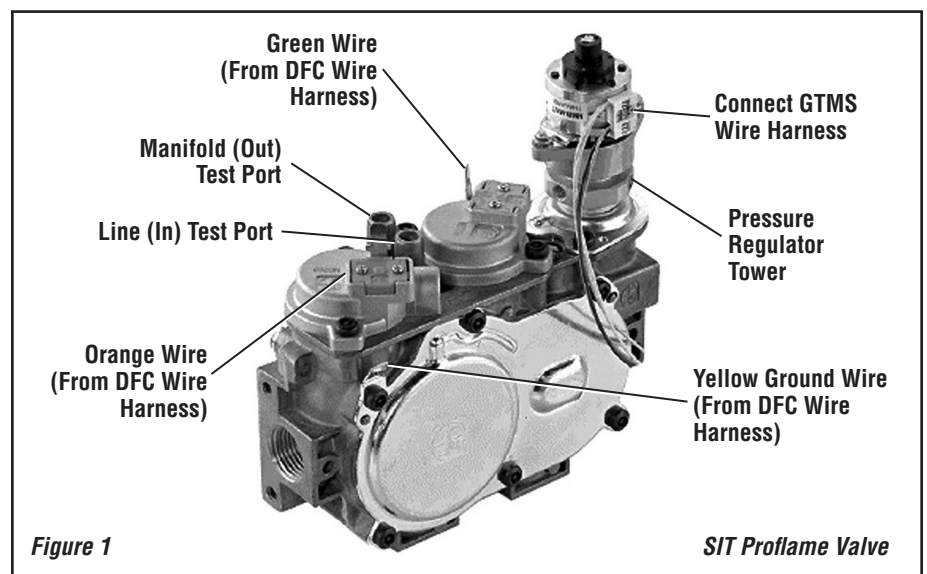

## Gas Valve

Refer to **Figure 1** for key gas valve features.

## Orifice Sizes - Sea Level to High Altitude (All Models)

These appliances are tested and approved for installation at elevations of 0-4500 feet (0-1372 meters) above sea level using the standard burner orifice sizes (marked with an "\*" in **Table 5**).

For elevations above 4500 feet, contact your gas supplier or qualified service technician.

**Deration** - At higher elevations, the amount of BTU fuel value delivered must be reduced by either:

- Using gas that has been derated by the gas company.
- By changing the burner orifice to a smaller size as regulated by the local authorities having jurisdiction and by the (USA) National Fuel Gas Code NFPA 54/ANSI Z223.1 - latest edition or, in Canada, the CAN/CSA-B149.1 codes - latest edition.

Install the appliance according to the regulations of the local authorities having jurisdiction and, in the USA, the National Fuel Gas Code NFPA 54 / ANSI Z223.1 - latest edition or, in Canada, the CAN/CSA-B149.1 - latest edition.

Flame breadth, height and width will diminish 4% for every 1,000 feet of altitude.

Burner Orifice Sizes Elevation 0-4500 feet ( 0-1372 meters)		
Model Series	Nat. Gas drill size (inches)	Propane drill size (inches)
SYM-35	#35 (0.110")* 21L80•	(0.062")* 21L01•
SYM-40	#32 (0.116")* 37L82•	(0.065")* 74L88•
SYM-45	(0.119")* 39L09•	(0.068")* H7875•

**Table 5** \* Standard size installed at factory  
• Part/Cat. Number

## REQUIREMENTS FOR THE COMMONWEALTH OF MASSACHUSETTS

These fireplaces are approved for installation in the US state of Massachusetts if the following additional requirements are met:

- Install this appliance in accordance with Massachusetts Rules and Regulations 248 C.M.R.
- Installation and repair must be done by a plumber or gas fitter licensed in the Commonwealth of Massachusetts.
- The flexible gas line connector used shall not exceed 36 inches (92 centimeters) in length.
- The individual manual shut-off must be a T-handle type valve.

## Massachusetts Horizontal Vent Requirements

In the Commonwealth of Massachusetts, horizontal terminations installed less than seven (7) feet above the finished grade must comply with the following additional requirements:



- A hard wired carbon monoxide detector with an alarm and battery back-up must be installed on the floor level where the gas fireplace is installed. The carbon monoxide detector must comply with NFPA 720, be ANSI/UL 2034 listed and be ISA certified.
- A metal or plastic identification plate must be permanently mounted to the exterior of the building at a minimum height of eight (8) feet above grade and be directly in line with the horizontal termination. The sign must read, in print size no less than one-half (1/2) inch in size, GAS VENT DIRECTLY BELOW. KEEP CLEAR OF ALL OBSTRUCTIONS.

## NEW YORK CITY, NEW YORK (MEA)

Installation of these fireplaces are approved for installation in New York City in the US state of New York.

## COLD CLIMATE INSULATION

For cold climate installations, seal all cracks around your appliance with noncombustible material and wherever cold air could enter the room. It is especially important to insulate outside chase cavity between studs and under floor on which appliance rests, if floor is above ground level. Gas line holes and other openings should be caulked or stuffed with unfaced fiberglass insulation.

If the fireplace is being installed on a cement slab in cold climates, a sheet of plywood or other raised platform can be placed underneath to prevent conduction of cold transferring to the fireplace and into the room. It also helps to sheetrock inside surfaces and tape for maximum air tightness and caulk firestops.

## MANUFACTURED HOME REQUIREMENTS

This appliance may be installed in an aftermarket permanently located, manufactured home and must be installed in accordance with the manufacturer's instructions and the Manufactured Home Construction and Safety Standard, Title 24 CFR, Part 3280, in the United States, or the Standard for Installation in Mobile Homes, CAN/CSA Z240 MH Series, in Canada.

Cet appareil peut être installé comme du matériel d'origine dans une maison préfabriquée (É.U. seulement) ou mobile et doit être installé selon les instructions du fabricant et conformément à la norme Manufactured Home Constructions and Safety, Title 24 CFR, Part 3200 aux Unis ou à la norme Can/CSA-Z240 Série MM, Maisons mobiles au Canada.

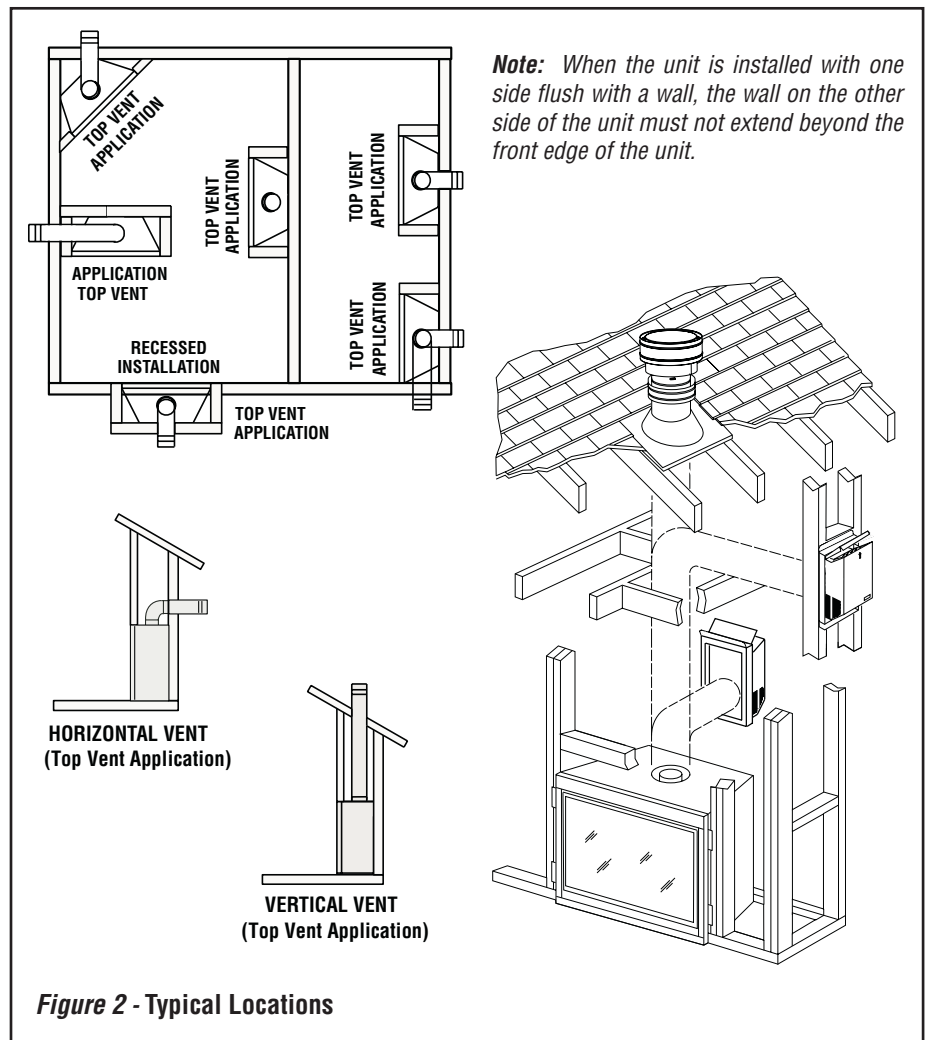

This appliance is only for use with the type of gas indicated on the rating plate. This appliance is not convertible for use with other gases, unless a certified kit is used.

Cet appareil doit être utilisé uniquement avec le type de gaz indiqué sur la plaque signalétique. Cet appareil ne peut être converti à d'autres gaz, sauf si une trousse de conversion est utilisée.

**CAUTION: Ensure that the cross members are not cut or weakened during installation. The structural integrity of the manufactured home floor, wall, and ceiling / roof must be maintained.**

**CAUTION: This appliance must be grounded to the chassis of the manufactured home in accordance with local codes or in the absence of local codes, with the National Electrical Code ANSI / NFPA 70 - latest edition or the Canadian Electrical Code CSA C22.1 - latest edition.**

## LOCATION

In selecting the location, the aesthetic and functional use of the appliance are primary concerns. However, vent system routing to the exterior and access to the fuel supply are also important.

**Due to high temperatures, the appliance should be located out of traffic and away from furniture and draperies (Figure 2).**

**En raison des températures élevées, l'appareil devrait être installé dans un endroit où il y a peu de circulation et loin du mobilier et des tentures (Figure 2).**

The location should also be free of electrical, plumbing or other heating/air conditioning ducting.

These direct-vent appliances are uniquely suited for installations requiring a utility shelf positioned directly above the fireplace. Utility shelves like these are commonly used for locating television sets and decorative plants.

**Be aware that this is a heat producing appliance. Objects placed above the unit are exposed to elevated temperatures.**

**Do not insulate the space between the appliance and the area above it (see Figure 7).**

The minimum height from the base of the appliance to the underside of combustible materials used to construct a utility shelf in this fashion is shown in **Figure 7**.

The appliance should be mounted on a fully supported base extending the full width and depth of the unit. The appliance may be located on or near conventional construction materials. However, if installed on combustible materials, such as carpeting, vinyl tile, etc., a metal or wood barrier covering the entire bottom surface must be used.

### VENT TERMINATION CLEARANCES

These instructions should be used as a guideline and do not supersede local codes in any way. Install venting according to local codes, these instructions, the current National Fuel Gas Code (ANSI-Z223.1) in the USA or the current standards of CAN/CSA-B149.1 in Canada.

#### Vertical Vent Termination Clearances

Terminate multiple vent terminations according to the installation codes listed above. Also see **Figure 3**.

Terminate single vent caps relative to building components according to **Figure 4**.

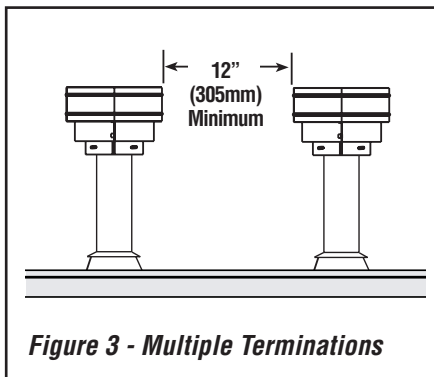

### Vertical Vent Termination Clearances

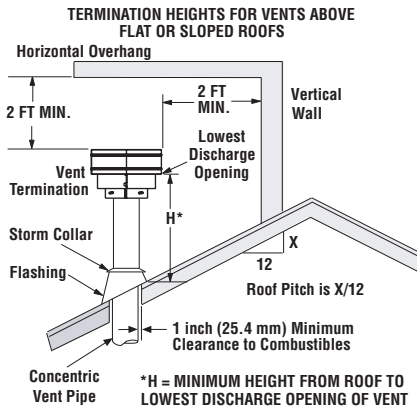

The vent / air intake termination clearances above the high side of an angled roof is as shown in the following chart:

**Figure 4**

Termination Heights For Vents Above Flat Or Sloped Roofs Ref. NFPA 54 / ANSI Z223.1		
Roof Pitch	* Feet	* Meters
Flat to 6/12	1.0	0.3
6/12 to 7/12	1.25	0.38
7/12 to 8/12	1.5	0.46
8/12 to 9/12	2.0	0.61
9/12 to 10/12	2.5	0.76
10/12 to 11/12	3.25	0.99
11/12 to 12/12	4.0	1.22
12/12 to 14/12	5.0	1.52
14/12 to 16/12	6.0	1.83
16/12 to 18/12	7.0	2.13
18/12 to 20/12	7.5	2.29
20/12 to 21/12	8.0	2.44

### Horizontal Vent Termination Clearances

The horizontal vent termination must have a minimum of 6" (152 mm) clearance to any overhead combustible projection of 2-1/2" (64 mm) or less (see **Figure 5**). For projections exceeding 2-1/2" (64 mm), see **Figure 5**. For additional vent location restrictions refer to **Figure 6** on **Page 7**.

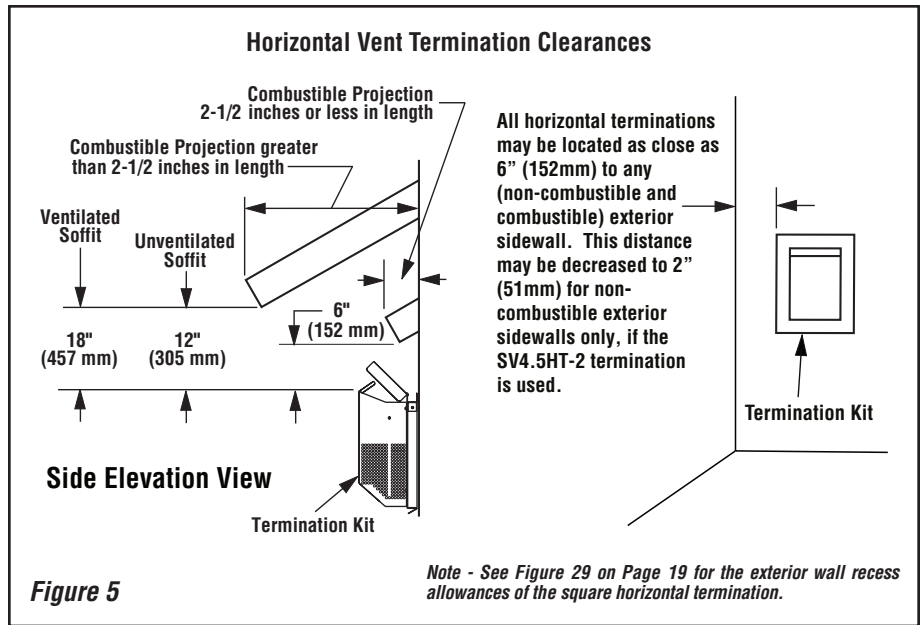

*Note - See Figure 29 on Page 19 for the exterior wall recess allowances of the square horizontal termination.*

# EXTERIOR HORIZONTAL VENT TERMINATION CLEARANCE REQUIREMENTS

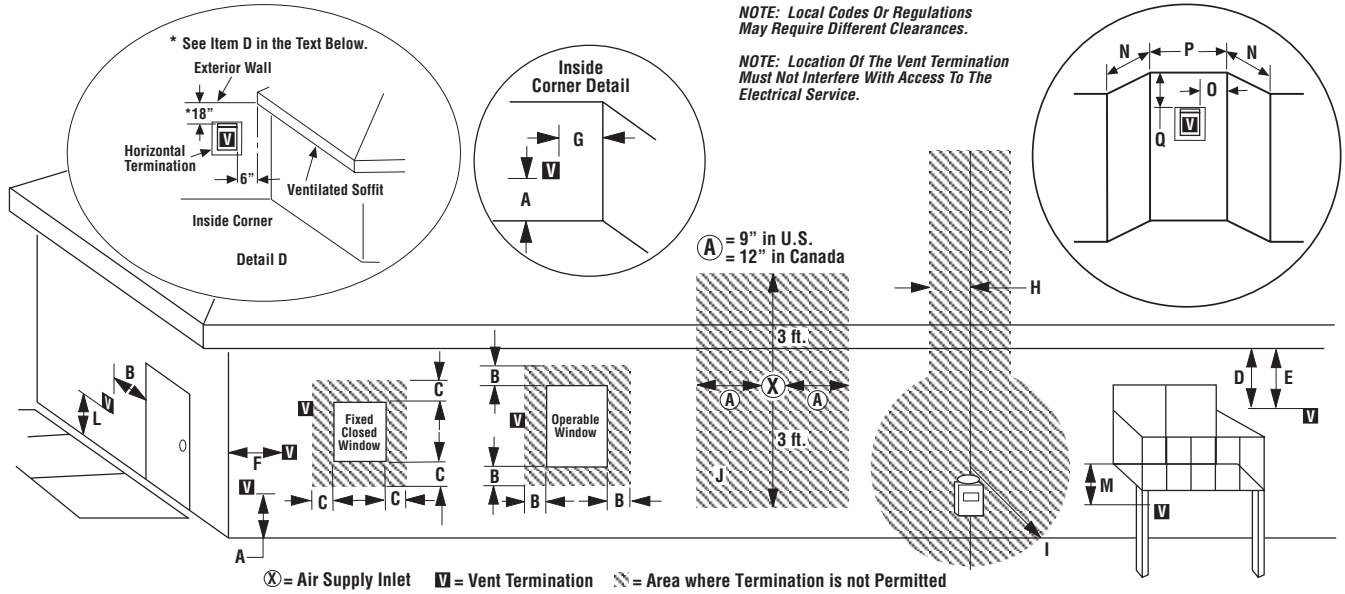

	Canadian Installation*	US Installation**
A = Clearance above grade, veranda, porch, deck, or balcony.	12 inches (30cm)*	12 inches (30cm)**
B = Clearance to window or door that may be opened.	6 inches (15cm) for appliances < 10,000 Btuh (3kW), 12 inches (30cm) for appliances > 10,000 Btuh (3kW)	6 inches (15cm) for appliances < 10,000 Btuh (3kW), 9 inches (23cm) for appliances > 10,000 Btuh (3kW) and < 50,000 Btuh (15kW), 12 inches (30cm) for appliances > 50,000 Btuh (15kW)**
C = Clearance to permanently closed window	12 inches (305mm) recommended to prevent window condensation	9 inches (229mm) recommended to prevent window condensation
D = Vertical clearance to ventilated soffit located above the termination within a horizontal distance of 18 inches (458mm) from the center line of the termination	18 inches (458mm)	18 inches (458mm)
E = Clearance to unventilated soffit***	12 inches (305mm)	12 inches (305mm)
F = Clearance to outside corner	5 inches (12.7cm) minimum	5 inches (12.7cm) minimum
G = Clearance to inside corner	2 inches (5.08cm) minimum - SV4.5HT-2	2 inches (5.08cm) minimum - SV4.5HT-2
H = Clearance to each inside of center line extended above meter/regulator assembly	3 feet (91cm) within a height of 15 feet above the meter/regulator assembly*	3 feet (91cm) within a height of 15 feet above the meter/regulator assembly**
I = Clearance to service regulator vent outlet	3 feet (91cm)*	3 feet (91cm)**
J = Clearance to nonmechanical air supply inlet to building or the combustion air inlet to any other appliance	6 inches (15cm) for appliances < 10,000 Btuh (3kW), 12 inches (30cm) for appliances > 10,000 Btuh (3kW)	6 inches (15cm) for appliances < 10,000 Btuh (3kW), 9 inches (23cm) for appliances > 10,000 Btuh (3kW) and < 50,000 Btuh (15kW), 12 inches (30cm) for appliances > 50,000 Btuh (15kW)**
K = Clearance to a mechanical air supply inlet	6 feet (1.83m)*	3 feet (91cm) above if within 10 feet (3m) horizontally**
L = Clearance above paved sidewalk or paved driveway located on public property	7 feet (2.13m)‡	7 feet (2.13m)‡
M = Clearance under veranda, porch, deck or balcony	12 inches (30cm)*‡	12 inches (30cm)‡
N = Depth of Alcove (Maximum)	6 feet (1.83m)*	6 feet (1.83m)**
O = Clearance to Termination (Alcove)	6 inches (15.2mm)*	6 inches (15.2mm)**
P = Width of Alcove (Minimum)	3 feet (91cm)*	3 feet (91cm)*
Q = Clearance to Combustible Above (Alcove)	18 inches (457mm)*	18 inches (457mm)**

\* In accordance with the current CSA-B149.1 National Gas And Propane Installation Code.

\*\* In accordance with the current ANSI S2223.1/NFPA 54 National Fuel Gas Codes.

\*\*\* Clearance required to vinyl soffit material - 30 inches (76cm) minimum.

‡ A vent shall not terminate directly above a sidewalk or paved driveway which is located between two single family dwellings and serves both dwellings.

\*‡ Only permitted if veranda, porch, deck or balcony is fully open on a minimum 2 sides beneath the floor.

Figure 6

NOTE: DIAGRAMS & ILLUSTRATIONS ARE NOT TO SCALE.





## ! WARNING

Failure to position the parts in accordance with these diagrams or failure to use only parts specifically approved with this appliance may result in property damage or personal injury.

## ! AVERTISSEMENT

Risque de dommages ou de blessures si les pièces ne sont pas installées conformément à ces schémas et ou si des pièces autres que celles spécifiquement approuvées avec cet appareil sont utilisées.

### DETAILED INSTALLATION STEPS

The appliance is shipped with all gas controls and components installed and pre-wired.

1. Remove the shipping carton. Remove the shipping pad, exposing the front glass door.
2. Open the two latches (located under the firebox floor) securing the glass door. Remove the door by tilting it outward at the bottom and lifting it up. Set the door aside protecting it from inadvertent damage. See *Removing and Installing Glass Doors* on **Page 32**.
3. Remove the top louvered panel and locate the pressure relief plates (see **Figure 10**).
4. Lift the pressure relief plates and remove the cardboard from beneath each plate (be careful not to damage the white gasket).

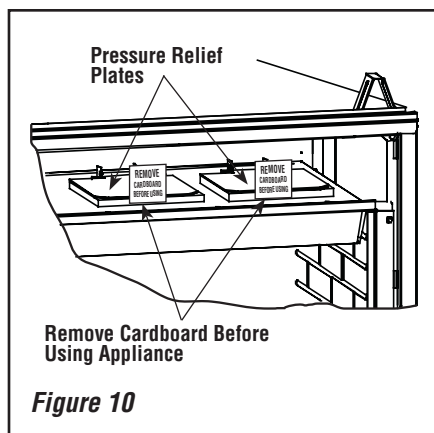

### TYPICAL INSTALLATION SEQUENCE

The typical sequence of installation is outlined below. However, each installation is unique and may result in variations to the steps described.

See the page numbers references in the following steps for detailed procedures.

- Step 1. (Page 9)** Construct the appliance framing. Position the appliance within the framing and secure with nailing brackets. Bend out the appropriate nailing flanges for the drywall/finish material to be used. Nailing flanges are provided for flush framing, 1/2 inch and 5/8 inch framing depths (see **Figure 11**).
- Step 2. (Page 11)** Route gas supply line to appliance location.
- Step 3. (Page 12)** Install the vent system and exterior termination.
- Step 4. (Page 24)** Field Wiring.
- Step 5. (Page 26)** Make connection to gas supply.
- Step 6. (Page 27)** Verifying appliance operation.
- Step 7. (Page 27)** Install the logs, decorative volcanic stone and glowing embers.
- Step 8. (Page 32)** Removing and Installing glass door assembly.
- Step 9. (Page 32)** Adjust burner to ensure proper flame appearance.
- Step 10. (Page 34)** Install the hoods.
- Step 11. (Page 35)** Attach Safety in Operation Warnings.

### Step 1. FRAMING

Frame these appliances as illustrated in **Figures 12** and **13** on **Pages 10** and **11** (**Figure 13** applies to corner framing installations only). All framing details must allow for a minimum clearance to combustible framing members as shown in **Table 6 on Page 8**.

If the appliance is to be elevated above floor level, a solid continuous platform must be constructed below the appliance.

Headers may be in direct contact with the appliance top spacers when they are bent up vertically maintaining the 3" clearance to the fireplace top, but must not be supported by them or notched to fit around them. All construction above the appliance must be self-supporting. **DO NOT** use the appliance for structural support.

The fireplace should be secured to the side framing members using the unit's nailing flanges - one top and bottom on each side of the fireplace front. See **Figure 11**. Use 8d nails or their equivalent.

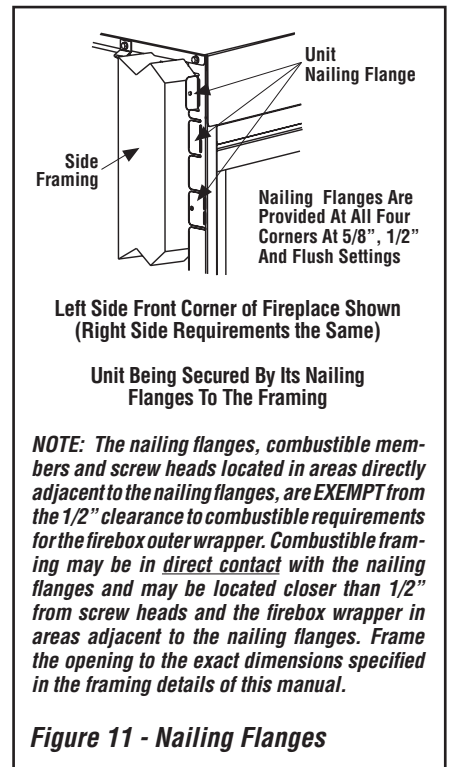

# FIREPLACE AND FRAMING SPECIFICATIONS

## Framing

Framing Dimensions					
Model No.		A	B	C	D
SYM-35	in.	35-9/16	40-5/16	21-7/16	56-1/2
	mm	903	1024	545	1435
SYM-40	in.	40-9/16	40-5/16	21-7/16	56-1/2
	mm	1030	1024	545	1435
SYM-45	in.	45-9/16	40-5/16	21-7/16	56-1/2
	mm	1157	1024	545	1435

Efficiencies %						
Models	Natural Gas			Propane		
	P4*	Steady State	AFUE **	P4*	Steady State	AFUE **
SYM-35	61.7	70.6	64.8	62.4	71.3	65.2
SYM-40	60.7	70.7	64.3	61.2	72.1	64.6
SYM-45	63.9	72.4	66.2	64.2	73.1	66.3

Vent Size	
Co-axial DV Vent Size	4-1/2" Inner 7-1/2" Outer

Input (BTU/HR) - MV & Electronic	
Natural & Propane Gas	
Models	Input Rate (BTU / HR)
SYM-35N	33,000
SYM-35P	27,500
SYM-40N	37,000
SYM-40P	32,000
SYM-45N	39,000
SYM-45P	33,500

Canadax  
**ENERGUIDE**  
Look for the **ENERGUIDE** Gas Fireplace Energy Efficiency Rating in this brochure  
Based on CSA P.4.1-02

**Notes**  
Diagrams, illustrations and photographs are not to scale - consult installation instructions. Product designs, materials, dimensions, specifications, colors and prices are subject to change or discontinuance without notice.

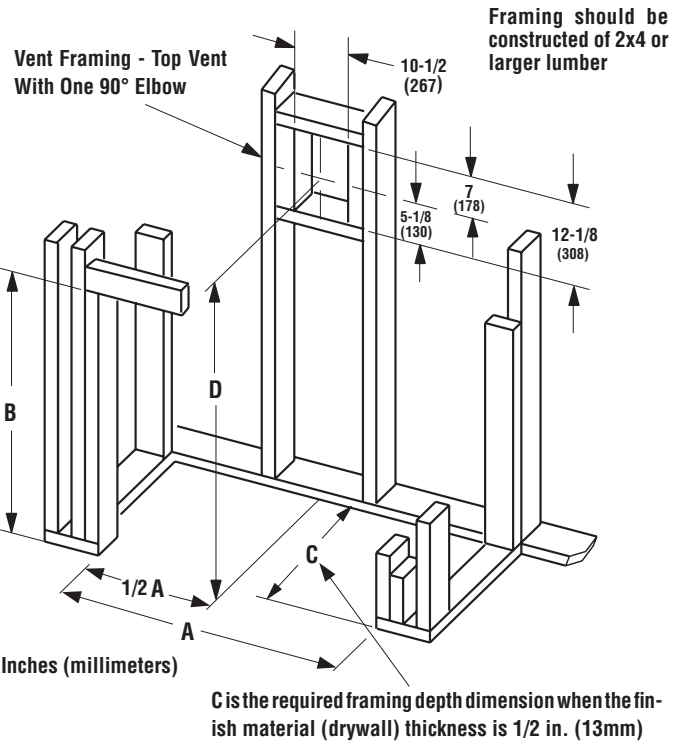

### Vertical Venting Through the Ceiling:

**Frame ceiling opening** - Use a plumb line from the ceiling above the appliance to locate center of the vertical run. Cut and/or frame an opening, 10-1/2" x 10-1/2" (267 mm x 267 mm) inside dimensions, about this center mark (**see Figure 17**).

NOTE: - The gas is to be stubbed in from the left side ONLY.

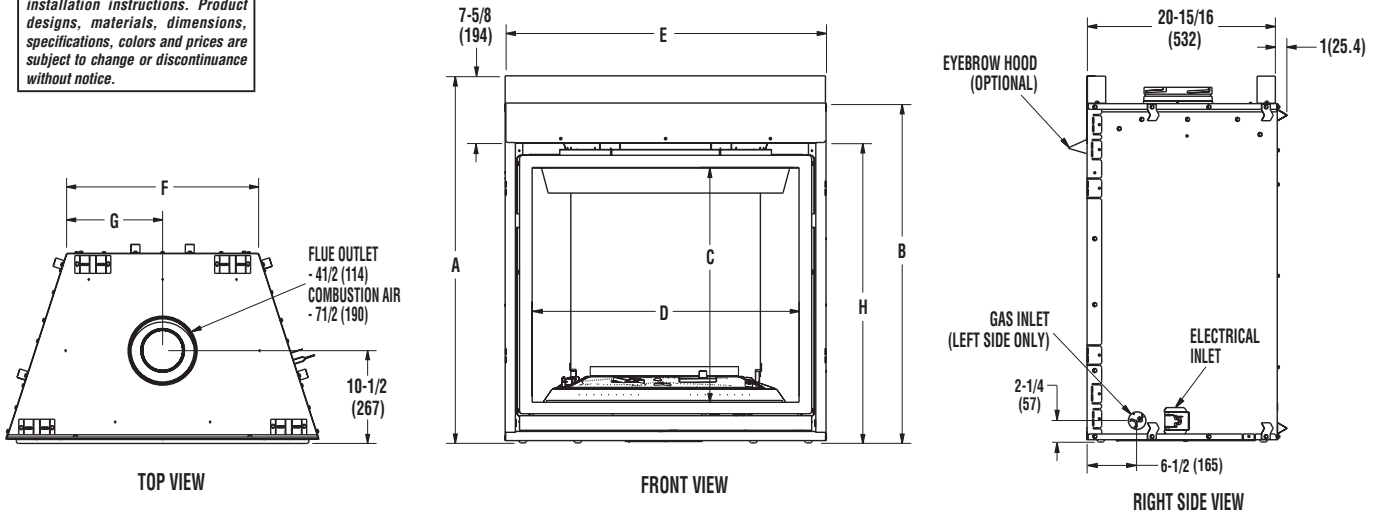

Model No.		A	B	C	D	E	F	G	H
SYM-35	in.	40 1/8	37 1/8	25 5/8	29 1/8	35 1/8	21 1/2	10 3/4	32 1/2
	mm	1091	943	651	740	892	546	273	825
SYM-40	in.	40 1/8	37 1/8	25 5/8	34 1/8	40 1/8	26 1/2	13 3/4	32 1/2
	mm	1091	943	651	867	1019	675	337	825
SYM-45	in.	40 1/8	37 1/8	25 5/8	39 1/8	45 1/8	31 1/2	15 3/4	32 1/2
	mm	1091	943	651	994	1146	802	401	825

Viewable Glass Size	
35" Model	29-1/4" Wide 20-1/4" High
40" Model	34-1/4" Wide 25-1/4" High
45" Model	39-1/4" Wide 25-1/4" High

Figure 12

NOTE: DIAGRAMS & ILLUSTRATIONS ARE NOT TO SCALE.

# FIREPLACE FRAMING SPECIFICATIONS

Model No.		A	B	C	D	E
SYM-35	in.	35 3/16	63 5/8	45	15 7/16	31 13/16
	mm	892	1143	1143	392	708
SYM-40	in.	40 3/16	68 5/8	48 1/2	17 1/4	34 3/8
	mm	1021	1743	1232	438	873
SYM-45	in.	45 3/16	73 5/8	52	19	36 3/4
	mm	1148	1870	1321	483	933

Note-  
Venting requirements for corner installations - the horizontal vent length "a" to "b," must not exceed 28 inches (711 mm).

\*These dimensions occur when one 45 degree elbow is connected directly to the appliance collar.

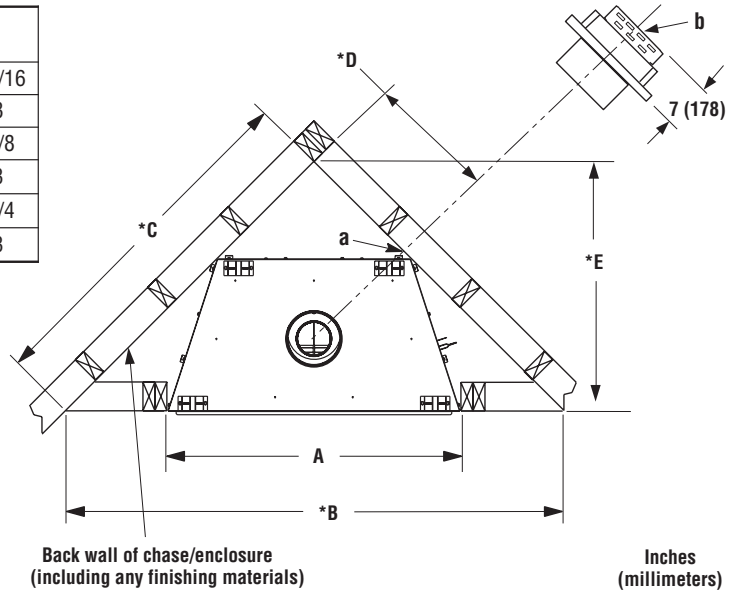
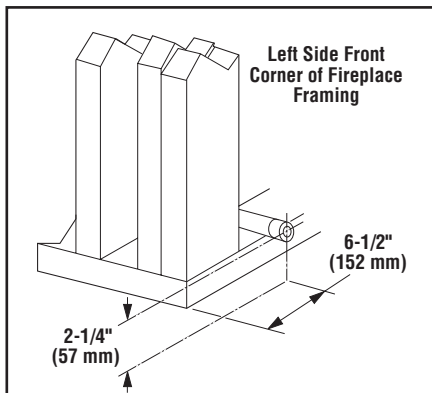

Figure 13 - Corner Framing with Horizontal Termination

## Step 2. ROUTING GAS LINE

Route a 1/2" (13 mm) gas line to the left side of the appliance as shown in **Figure 14**. Gas lines must be routed, constructed and made of materials that are in strict accordance with local codes and regulations. All appliances are factory-equipped with a flexible gas line connector and 1/2 inch shutoff valve. (See **Step 5 on Page 26**).



Also see Figure 12.

Figure 14 - Route Gas Line

## Proper Sizing of Gas Line

Properly size and route the gas supply line from the supply regulator to the area where the appliance is to be installed per requirements outlined in the National Fuel Gas Code, NFPA 54 - latest edition (USA) or CAN/CSA-B149.1 - latest edition (Canada).

Never use galvanized or plastic pipe. Refer to **Table 7** for proper sizing of the gas supply line, if black iron pipe is being used. Gas lines must be routed, constructed and made of materials that are in strict accordance with local codes and regulations.

We recommend that a qualified individual such as a plumber or gas fitter be hired to correctly size and route the gas supply line to the appliance. Installing a gas supply line from the fuel supply to the appliance involves numerous considerations of materials, protection, sizing, locations, controls, pressure, sediment, and more. Certainly no one unfamiliar and unqualified should attempt sizing or installing gas piping.

Schedule 40 Black Iron Pipe Inside Diameter (Inches)		
Schedule 40 Pipe Length (feet)	Natural Gas	Propane Gas
0-10	1/2	3/8
10-40	1/2	1/2
40-100	1/2	1/2
100-150	3/4	1/2
150-200	3/4	1/2

Table 7

## Notes:

- All appliances are factory-equipped with a flexible gas line connector and 1/2 inch shutoff valve (see **Figure 36 on Page 26**).
- See **Massachusetts Requirements on Page 4** for additional requirements for installations in the state of Massachusetts in the USA.
- The gas supply line should Not be connected to the appliance until **Step 5 (Page 26)**.
- A pipe joint compound rated for gas should be used on the threaded joints. **Ensure propane resistant compounds are used in propane applications.** Be very careful that the pipe compound does not get inside the pipe.
- It is recommended to install a sediment trap in the supply line as close as possible to the appliance. Appliances using Propane should have a sediment trap at the base of the tank.
- Check with local building official for local code requirements (i.e. are below grade penetrations of the gas line allowed?, etc).

**IMPORTANT: If propane is used, be aware that if tank size is too small (i.e. under 100-lbs, if this is the only gas appliance in the dwelling. Ref. NPFA 58), there may be loss of pressure, resulting in insufficient fuel delivery (which can result in sooting, severe delayed ignition or other malfunctions). Any damage resulting from an improper installation, such as this, is not covered under the limited warranty.**

### Step 3. INSTALL THE VENT SYSTEM

#### General Information

These instructions should be used as a guideline and do not supersede local codes in any way. Install venting according to local codes, these instructions, the current National Fuel Gas Code (ANSI-Z223.1) in the USA or the current standards of CAN/CSA-B149.1 in Canada.

Ensure clearances are in accordance with local installation codes and the requirements of the gas supplier.

Dégagement conforme aux codes d'installation locaux et aux exigences du fournisseur de gaz.

Use only approved venting components. See *Approved Vent Components* on Page 2.

These fireplaces must be vented directly to the outside.

The vent system may not service multiple appliances, and must never be connected to a flue serving a solid fuel burning appliance. The vent pipe is tested to be run inside an enclosed wall (such as a chase). There is no requirement for inspection openings in the enclosing wall at any of the joints in the vent pipe.

#### Installation of Vent Restrictor

A vent restrictor may be needed with this appliance. The restrictor is installed in the appliance top flue outlet as shown in **Figure 15**, either before adding vent, from above, or after installation of vent from below, within the firebox. The restrictor is self securing through a positive friction fit.

Determine the venting for the appliance. **If the vent run will include at least 8 feet of vertical rise, then install the restrictor in the appliance collar before connecting any vent (Refer to Figure 15).** Place the second restrictor inside the fixed restrictor.

**Note:** *The restrictor is included within the firebox.*

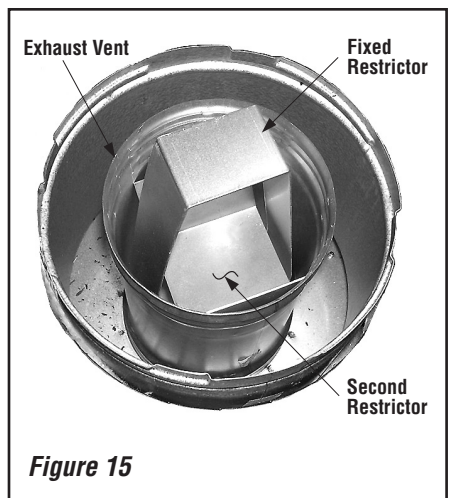

**Figure 15**

#### Select Venting System - Horizontal or Vertical

With the appliance secured in framing, determine vent routing and identify the exterior termination location. The following sections describe vertical (roof) and horizontal (exterior wall) vent applications. Refer to the section relating to your installation. **A list of approved venting components are shown on Pages 36 and 37.**



**VERTICAL TERMINATION SYSTEMS (ROOF)**

See **Figure 16** and **Figures 24 through 26** on **Pages 16 and 17** and their associated Vertical Vent Tables which illustrate the various vertical venting configurations that are possible for use with these appliances. **Secure Vent™** pipe applications are shown in these Figures; **Secure Flex™** pipe may also be used. A Vertical Vent Table summarizes each system's minimum and maximum vertical and horizontal length values that can be used to design and install the vent components in a variety of applications.

Both these vertical vent systems terminate through the roof. The minimum vent height above the roof and/or adjacent walls is specified in ANSI Z223.1-(latest edition) (In Canada, the current CAN/CSA-B149.1 installation code) by major building codes. Always consult your local codes for specific requirements. A general guide to follow is the Gas Vent Rule (refer to **Figure 4 on Page 6**).

**Vertical (Straight) Installation (Figure 16)**

Determine the number of straight vent sections required. 4-1/2" (114 mm), 10-1/2" (267 mm), 22-1/2" (572 mm), 34-1/2" (876 mm) and 46-1/2" (1181 mm) net section lengths are available (see **Tables on this page** and **Page 36 - Vent Sections**). Plan the vent lengths so that a joint does not occur at the intersection of ceiling or roof joists. Refer to the Vent Section Length Chart.

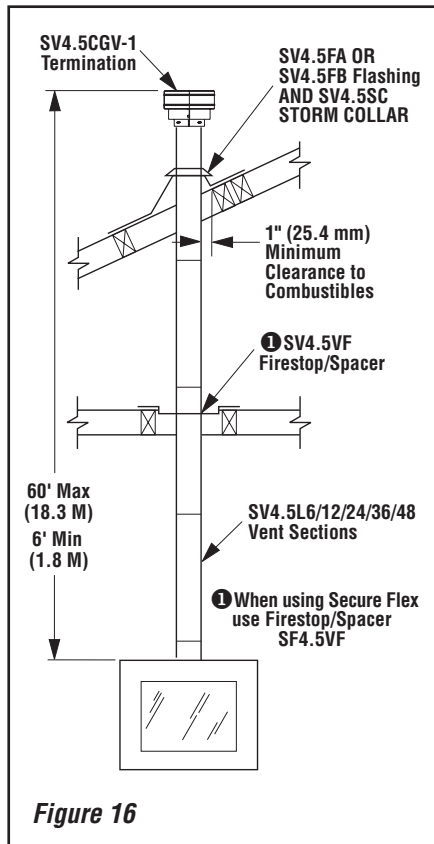

**Figure 16**

VENT SECTION LENGTH CHART						
Nominal Section Length (inches)	6	12	24	36	48	TOTAL
Net Section Length (inches)	4-1/2	10-1/2	22-1/2	34-1/2	46-1/2	
Height of Vent	Number of Vent Sections					
inches	ft					QTY
4.5	0.375	1	0	0	0	1
9	0.75	2	0	0	0	2
10.5	0.875	0	1	0	0	1
15	1.25	1	1	0	0	2
22.5	1.875	0	0	1	0	1
31.5	2.625	0	3	0	0	3
34.5	2.875	0	0	0	1	1
37.5	3.125	1	1	1	0	3
43.5	3.625	0	2	1	0	3
45	3.75	0	0	2	0	2
46.5	3.875	0	0	0	0	1
51	4.25	1	0	0	0	1
55.5	4.625	0	1	2	0	3
57	4.75	0	0	1	1	2
67.5	5.625	0	0	3	0	3
69	5.75	0	0	0	2	2
73.5	6.125	1	0	0	2	3
79.5	6.625	0	1	0	2	3
81	6.75	0	0	0	1	1
91.5	7.625	0	0	2	0	1
93	7.75	0	0	0	0	2
97.5	8.125	1	0	0	0	2
103.5	8.625	0	0	0	3	3
108	9	1	0	0	3	4
117	9.75	1	0	5	0	6
118.5	9.875	1	1	0	3	5
126	10.5	0	0	1	3	4
130.5	10.875	1	0	1	3	5
135	11.25	0	0	6	0	6
139.5	11.625	0	0	0	0	3
142.5	11.875	1	0	0	4	5
144	12	1	0	0	0	3
154.5	12.875	1	1	0	0	3
160.5	13.375	0	2	0	0	3
172.5	14.375	0	0	0	5	5
177	14.75	1	0	0	5	6
186	15.5	0	0	0	0	4
196.5	16.375	0	1	0	0	4
207	17.25	0	0	0	6	6
211.5	17.625	1	0	0	6	7
217.5	18.125	0	1	0	6	7
229.5	19.125	0	0	1	6	7
232.5	19.375	0	0	0	0	5
241.5	20.125	0	0	0	7	7
246	20.5	1	0	0	7	8
252	21	0	1	0	7	8

**Note:** Convert inches into metric equivalent measurement, as follows:

- Millimeters (mm) = Inches x 25.4
- Centimeters (cm) = Inches x 2.54
- Meters (M) = Inches x .0254

VENT SECTION LENGTH CHART						
Nominal Section Length (inches)	6	12	24	36	48	TOTAL
Net Section Length (inches)	4-1/2	10-1/2	22-1/2	34-1/2	46-1/2	
Height of Vent	Number of Vent Sections					
inches	ft					QTY
276	23	0	0	0	8	8
279	23.25	0	0	0	0	6
280.5	23.375	1	0	0	8	9
289.5	24.125	0	1	0	0	6
301.5	25.125	0	0	1	0	6
310.5	25.875	0	0	0	9	9
325.5	27.125	0	0	0	0	7
330	27.5	1	0	0	0	7
345	28.75	0	0	0	10	10
349.5	29.125	1	0	0	10	11
372	31	0	0	0	0	8
379.5	31.625	0	0	0	11	11
418.5	34.875	0	0	0	0	9
465	38.75	0	0	0	0	10
475.5	39.625	0	1	0	0	10
480	40	1	1	0	0	10
492	41	1	0	1	0	10
499.5	41.625	0	0	0	1	10
504	42	1	0	0	1	10
511.5	42.625	0	0	0	0	11
520.5	43.375	0	2	0	1	11
531	44.25	0	2	2	0	11
538.5	44.875	1	0	0	2	11
549	45.75	1	0	2	1	11
558	46.5	0	0	0	0	12
562.5	46.875	1	0	0	0	12
568.5	47.375	0	1	0	0	12
573	47.75	1	1	0	0	12
580.5	48.375	0	0	1	0	12
589.5	49.125	0	1	2	2	10
595.5	49.625	1	1	1	0	12
604.5	50.375	0	0	0	0	13
615	51.25	0	1	0	0	13
625.5	52.125	0	2	0	0	13
631.5	52.625	1	0	1	0	13
637.5	53.125	0	1	1	0	13
651	54.25	0	0	0	0	14
655.5	54.625	1	0	0	0	14
672	56	0	2	0	0	14
678	56.5	1	0	1	0	14
688.5	57.375	1	1	1	0	14
697.5	58.125	0	0	0	0	15
702	58.5	1	0	0	0	15
712.5	59.375	1	1	0	0	15
720	60	0	0	1	0	15

Effective Vent Length	
Model	Effective Length
SV4.5L6	4-1/2"
SV4.5L12	10-1/2"
SV4.5L24	22-1/2"
SV4.5L36	34-1/2"
SV4.5L48	46-1/2"

**Table 8**

NOTE: DIAGRAMS & ILLUSTRATIONS ARE NOT TO SCALE.

## Vertical (Offset) Installation

Analyze the vent routing and determine the quantities of vent sections and number of elbows required. Refer to **Vertical Vent Figures and Tables on Pages 16 and 17** to select the type of vertical installation desired. Vent sections are available in net lengths of 4-1/2" (114 mm), 10-1/2" (267 mm), 22-1/2" (572 mm), 34-1/2" (876 mm) and 46-1/2" (1181 mm). Refer to the **Vent Section Length Charts on Page 13** for an aid in selecting length combinations. Elbows are available in 90° and 45° configurations. Refer to **Figure 20 on Page 15** for the SV4.5E45 and SV4.5E90 elbow dimensional specifications.

Where required, a **telescopic vent section (SV4.5LA)** may be used to provide the installer with an option in installing in tight and confined spaces or where the vent run made up of fixed length pieces develops a joint in a undesirable location, or will not build up to the required length. The SV4.5LA Telescopic Vent Section has an effective length of from 1-1/2" (38 mm) to 7-1/2" (191 mm). The SV4.5LA is fitted with a locking inclined channel end (identical to a normal vent section component) and a plain end with 3 pilot holes. Slip the plain end over the locking channel end of a standard SV4.5 vent component the required distance and secure with three screws.

**Maintain a minimum 1" (25 mm) clearance to combustible materials for all vertical elements. Clearances for all horizontal elements are 3" (76 mm) on top, 1" (25 mm) on sides and 1" (25 mm) on the bottom.**

**A. Frame ceiling opening** - Use a plumb line from the ceiling above the appliance to locate center of the vertical run. Cut and/or frame an opening, 10-1/2" x 10-1/2" (267mm x 267mm) inside dimensions, about this center mark (**Figure 17**).

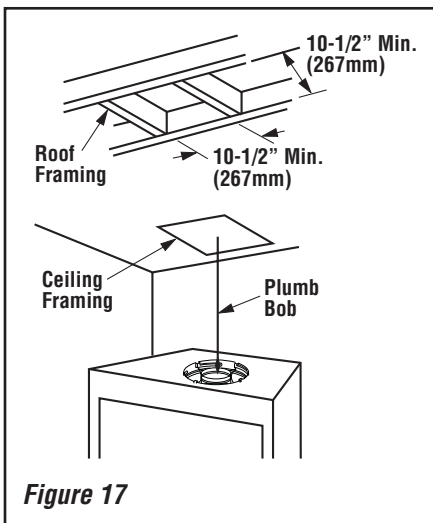

Figure 17

**B. Attach vent components to appliance - Secure Vent** SV4.5 direct-vent system components are unitized concentric pipe components featuring positive twist lock connections (see **Figure 18**).

All of the appliances covered in this document are fitted with collars having locking inclined channels. The dimpled end of the vent components fit over the appliance collar to create the positive twist lock connection.

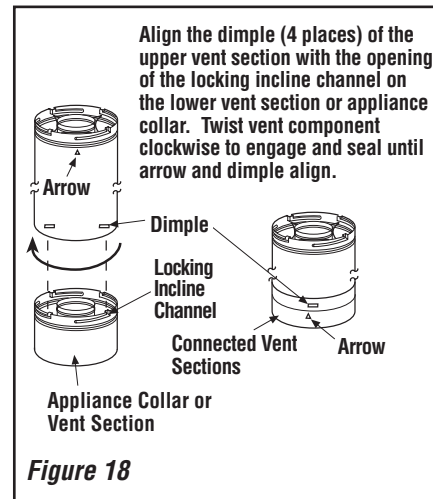

Figure 18

To attach a vent component to the appliance collar, align the dimpled end over the collar, adjusting the radial alignment until the four locking dimples are aligned with the inlet of the four inclined channels on the collar (refer to **Figure 18**). Push the vent component against the collar until it fully engages, then twist the component clockwise, running the dimples down and along the incline channels until they seat at the end of the channels. The unitized design of the **Secure Vent™** components will engage and seal both the inner and outer pipe without the need for sealant or screws. If desired, a #6 x 1/2" screw may be used at the joint, but is not required as the pipe will securely lock when twisted.

**Note: An elbow may not be directly attached to the appliance collar.**

**C. Attach vent components to each other** - Other vent sections may be added to the previously installed section in accordance with the requirements of the vertical vent Figures and Tables. To add another vent component to a length of vent run, align the dimpled end over the inclined channel end of the previously installed section, adjusting the radial alignment until the four locking dimples are aligned with the inlets of the four incline channels of the previous section.

Push the vent component against the previous section until it fully engages, then twist the component clockwise running the dimples down and along the incline channels until they seat at the end of the channels. **This seating position is indicated by the alignment of the arrow and dimple as shown in Figure 18.**

**D. Install firestop/spacer at ceiling** - When using Secure Vent™, use SV4.5VF firestop/spacer at ceiling joists; when using Secure Flex™, use SF4.5VF firestop/spacer. If there is living space above the ceiling level, the firestop/spacer must be installed on the bottom side of the ceiling. If attic space is above the ceiling, the firestop/spacer must be installed on the top side of the joist.

Route the vent sections through the framed opening and secure the firestop/spacer with 8d nails or other appropriate fasteners at each corner. **Remember to maintain 1" (25 mm) clearance to combustibles, framing members, and attic or ceiling insulation when running vertical chimney sections. Attic insulation shield (H3907) may be used to obtain the required clearances indicated here. See installation accessories Pages 36 and 37.** The gap between the vent pipe and a vertical firestop can be sealed with non-combustible caulking.

**E. Support the vertical vent run sections** -

**Note** - Proper venting support is very important. The weight of the vent must not be supported by the fireplace in any degree.

Support the vertical portion of the venting system every 8 feet (2.4m) above the fireplace vent outlet (see **Figure 19**).

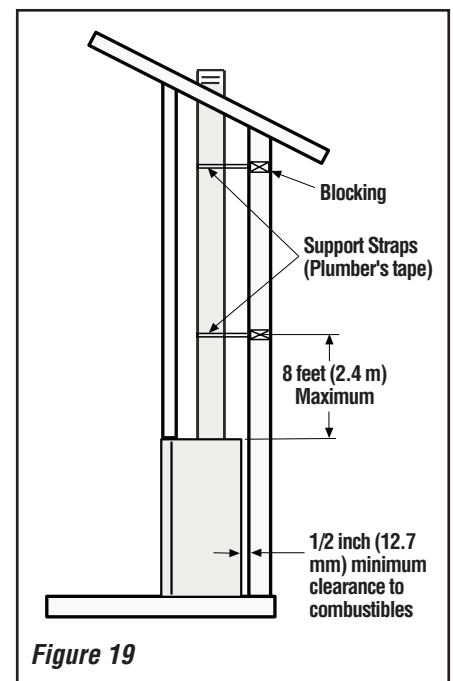
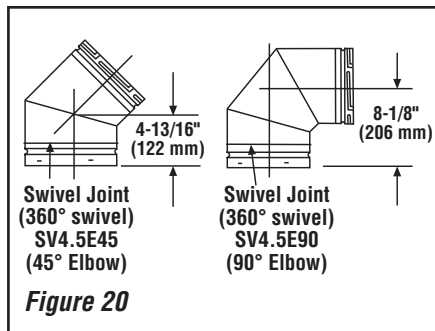

Figure 19

One method of support is by utilizing field provided support straps (conventional plumber's tape). Secure the plumber's tape to the framing members with nails or screws. Loop the tape around the vent, securing the ends of the tape to the framing. If desired, sheet metal screws #6 x 1/2" length may be used to secure the support straps to the vent pipe. Refer to **Figure 19**.

**F. Change vent direction to horizontal/inclined run** - At transition from or to a horizontal/inclined run, install the SV4.5E45 and SV4.5E90 elbows in the same manner as the straight vent sections. The elbows feature a twist section to allow them to be routed about the center axis of their initial collar section to align with the required direction of the next vent run element. **Twist elbow sections in a clockwise direction only so as to avoid the possibility of unlocking any of the previously connected vent sections (see Figure 20).**



**G. Continue installation of horizontal/inclined sections** - Continue with the installation of the straight vent sections in horizontal/inclined run as described in **Step C**. Install support straps every 5 ft. (1.52 m) along horizontal/inclined vent runs using conventional plumber's tape. **See Page 18, Figure 27. It is very important that the horizontal/inclined run be maintained in a straight (no dips) and recommended to be in a slightly elevated plane, in a direction away from the fireplace of 1/4" rise per foot (20 mm per meter) which is ideal,** though rise per foot run ratios that are smaller are acceptable all the way down to at or near level. Use a carpenter's level to measure from a constant surface and adjust the support straps as necessary.

**It is important to maintain the required clearances to combustibles: 1" (25 mm) at all sides for all vertical runs; and 3" (76 mm) at the top, 1" (25 mm) at sides, and 1" (25 mm) at the bottom for all horizontal/inclined runs.**

**H. Frame roof opening** - Identify location for vent at the roof. Cut and/or frame opening per Roof Framing Chart (**Figure 21**).

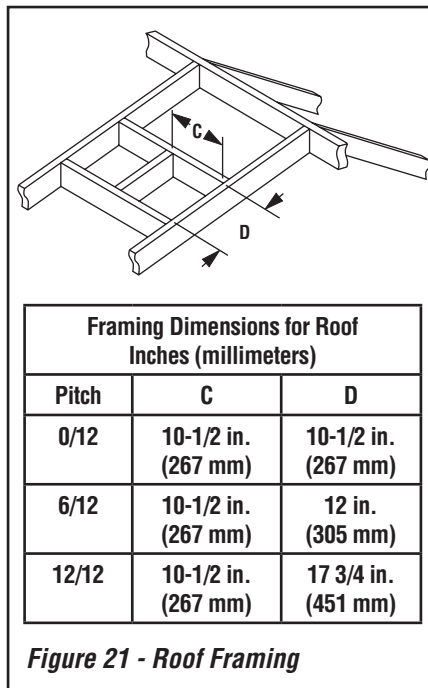

**Figure 21 - Roof Framing**

**I. Install the roof flashing** - Extend the vent sections through the roof structure. Install the roof flashing over the vent section and position such that the vent column rises vertically (use carpenter's level) (**Figure 22**). Nail along perimeter to secure flashing or adjust roofing to overlap the flashing edges at top and sides only and trim where necessary. Seal the top and both sides of the flashing with waterproof caulking.

**J. Install the storm collar** - Install the storm collar, supplied with the flashing, over the vent/flashing joint (see **Figure 22**). Loosen the storm collar screw. Slide collar down until it meets the top of the flashing. Tighten the adjusting screw. Apply non-combustible caulking or mastic around the circumference of the joint to provide a water tight seal.

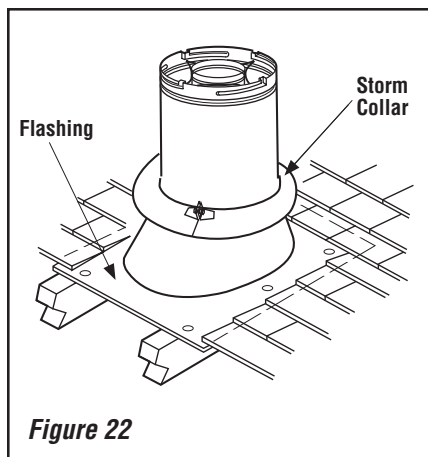

**Figure 22**

**K. Install the vertical termination** - The final step involves installation of the SV4.5CGV-1 Vertical Termination. Extend the vent sections to the height as shown in the "Vertical vent termination section" in **Figure 4 on Page 6**. The SV4.5CGV-1 Vertical Termination (**Figure 23**) can be installed in the exact same fashion as any other **Secure Vent™** section. Align the termination over the end of the previously installed section, adjusting the radial alignment until the four locking dimples of the termination are aligned with the inlets of the four incline channels of the last vent section. Push the termination down until it fully engages, then twist the termination clockwise running the dimples down and along the incline channels until they are seated at the end of the channels.

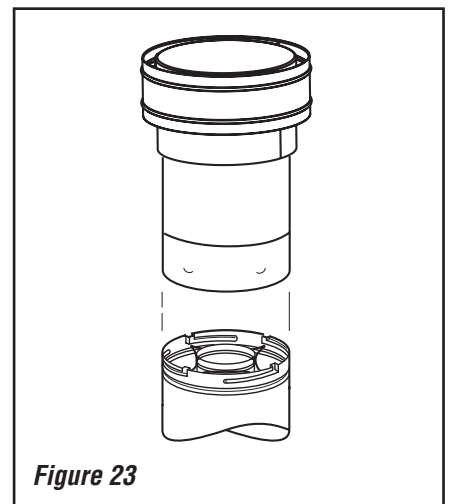

**Figure 23**

If the vent system extends more than 5 feet (1.5m) above the roof flashing, stabilizers may be necessary. Additional screws may be used at section joints for added stability. Guide wires may be attached to the joint for additional support on multiple joint configurations.

## VERTICAL VENT FIGURES/TABLES

### Notes:

- *Secure Vent™ (rigid vent pipe) is shown in the Figures; Secure Flex™ (flexible vent pipe) may also be used.*
- *It is very important that the horizontal/inclined run be maintained in a straight (no dips) and recommended to be in a slightly elevated plane, in a direction away from the fireplace of 1/4" rise per foot (20 mm per meter) which is ideal, though rise per foot run ratios that are smaller are acceptable all the way down to at or near level.*
- *SV4.5VF (Secure Vent), SF4.5VF (Secure Flex) firestop/spacer must be used anytime vent pipe passes through a combustible floor or ceiling. SV4.5HF (Secure Vent), SF4.5HF (Secure Flex) firestop/spacer must be used anytime vent pipe passes through a combustible wall.*
- *Two 45 degree elbows may be used in place of one 90 degree elbow. The same rise to run ratios, as shown in the venting Figures for 90 elbows, must be followed if 45 degree elbows are used.*
- **AN ELBOW IS ACCEPTABLE AS 1 FOOT OF VERTICAL RISE.**



## WARNING

**Under no circumstances, may separate sections of concentric flexible vent pipe be joined together.**

*Note: Install a second restrictor in any run having more than 8 ft. of vertical rise.*

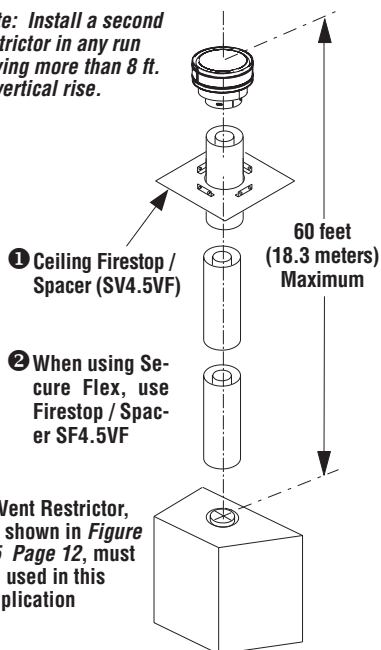

**Figure 24 - Top Vent - STRAIGHT**

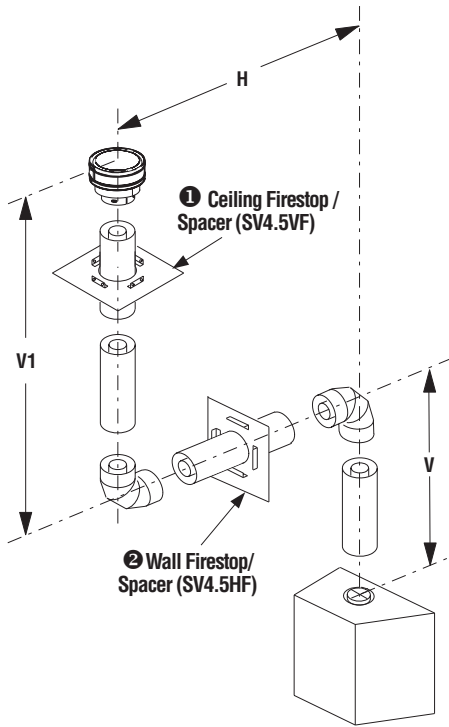

- 1 When using Secure Flex, use Firestop / Spacer SF4.5VF.
- 2 When using Secure Flex, use Firestop / Spacer SF4.5HF.

**Figure 25 - Top Vent - TWO 90 DEGREE ELBOWS**

V Minimum		H Maximum	
feet	(meters)	feet	(meters)
2	(0.601)	5	(1.524)
3	(0.914)	10	(3.1)
4	(1.22)	15	(4.65)
5	(1.524)	20	(6.2)
V + V <sub>1</sub> + H = 60 feet (18.3 m) Max.			
H = 20 feet (6.1 meters) Max.			

**Example:** If 20 feet of (H) horizontal vent run is needed, then 4 feet minimum of (V) vertical vent will be required.

This table shows a 1(V) to 5(H) ratio. For every 1 foot of (V) vertical, you are allowed 5 feet of (H) horizontal run, up to a maximum horizontal run of 20 feet.

An elbow is acceptable as 1 foot of vertical rise.

**Note:** Install a second restrictor in any run having more than 8 ft. of vertical rise.



**VERTICAL VENT FIGURES/TABLES (CONTINUED)**

Table B			
H + H <sub>1</sub> Maximum		V Minimum	
feet	(meters)	feet	(meters)
5	(1.524)	2	(0.601)
10	(3.1)	3	(0.914)
15	(4.65)	4	(1.22)
20	(6.2)	5	(1.524)
H + H <sub>1</sub> = 20 feet (6.096 m) Max. V + V <sub>1</sub> + H + H <sub>1</sub> = 60 ft. (18.3 m) Max.			

**Example:** If 20 feet total (H+H<sub>1</sub>) horizontal vent run is needed, then 4 feet minimum of (V) vertical will be required.

This table shows a 1(V) to 5(H) ratio. For every 1 foot of (V) vertical, you are allowed 5 feet of (H+H<sub>1</sub>) horizontal run up to a maximum total horizontal run of 20 feet.

An elbow is acceptable as 1 foot of vertical rise.

**Note:** Install a second restrictor in any run having more than 8 ft. of vertical rise.

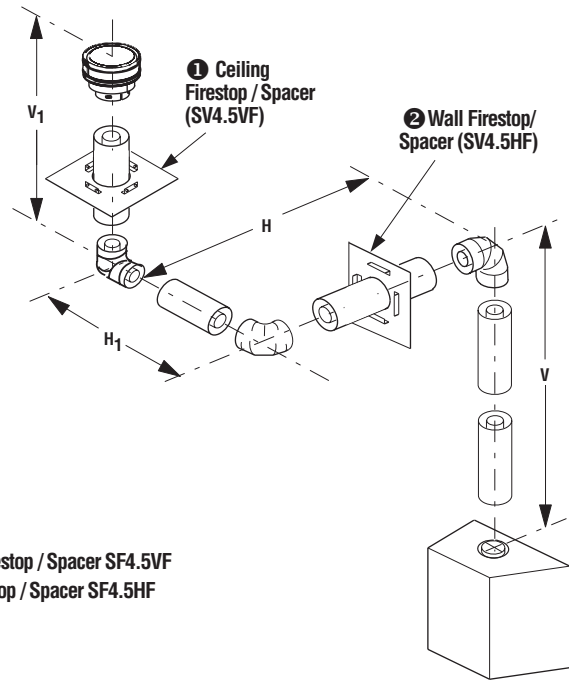

- ① When using Secure Flex™, use Firestop / Spacer SF4.5VF
- ② When using Secure Flex, use Firestop / Spacer SF4.5HF

**Figure 26 - Top Vent - THREE ELBOWS**

**HORIZONTAL (OUTSIDE WALL) TERMINATION SYSTEM**

See **Figure 27** on **Page 18**, and **Figures 30 through 32** on **Pages 20 through 22** and their associated Horizontal Vent Tables which illustrate the various horizontal venting configurations that are possible for use with these appliances. **Secure Vent™** pipe applications are shown in these Figures; **Secure Flex** pipe may also be used. A Horizontal Vent Table summarizes each system's minimum and maximum vertical and horizontal length values that can be used to design and install the vent components in a variety of applications.

Both of these horizontal vent systems terminate through an outside wall. Building Codes limit or prohibit terminating in specific areas. Refer to **Figure 6** on **Page 7** for location guidelines.

**Secure Vent** SV4.5 direct-vent system components are unitized concentric pipe components featuring positive twist lock connection, (refer to **Figure 18** on **Page 14**). All of the appliances covered in this document are fitted with collars having locking inclined channels. The dimpled end of the vent components fit over the appliance collar to create the positive twist lock connection.

**A. Plan the vent run -**

Analyze the vent routing and determine the types and quantities of sections required 4-1/2" (114 mm), 10-1/2" (267 mm), 22-1/2" (572 mm), 34-1/2" (876 mm) and 46-1/2" (1181 mm) net section lengths are available. It is recommended that you plan the vent lengths so that a joint does not occur at the intersection of ceiling or roof joists. Make allowances for elbows as indicated in **Figure 20**.

**Maintain a minimum 1" (25 mm) clearance to combustibles on the vertical sections. Clearances for the horizontal runs are; 3" (76 mm) on top, 1" (25 mm) on sides, and 1" (25 mm) at the bottom.**

**B. Frame exterior wall opening -**

Locate the center of the vent outlet on the exterior wall according to the dimensions shown in **Figure 12** on **Page 10**. Cut and/or frame an opening, 10-1/2" x 12 1/8" (267 mm x 308mm) inside dimensions, about this center.

**C. Frame ceiling opening -**

If the vertical route is to penetrate a ceiling, use plumb line to locate the center above the appliance. Cut and/or frame an opening, 10-1/2" x 10-1/2" (267 mm x 267 mm) inside dimensions, about this center (refer to **Figure 17** on **Page 14**).

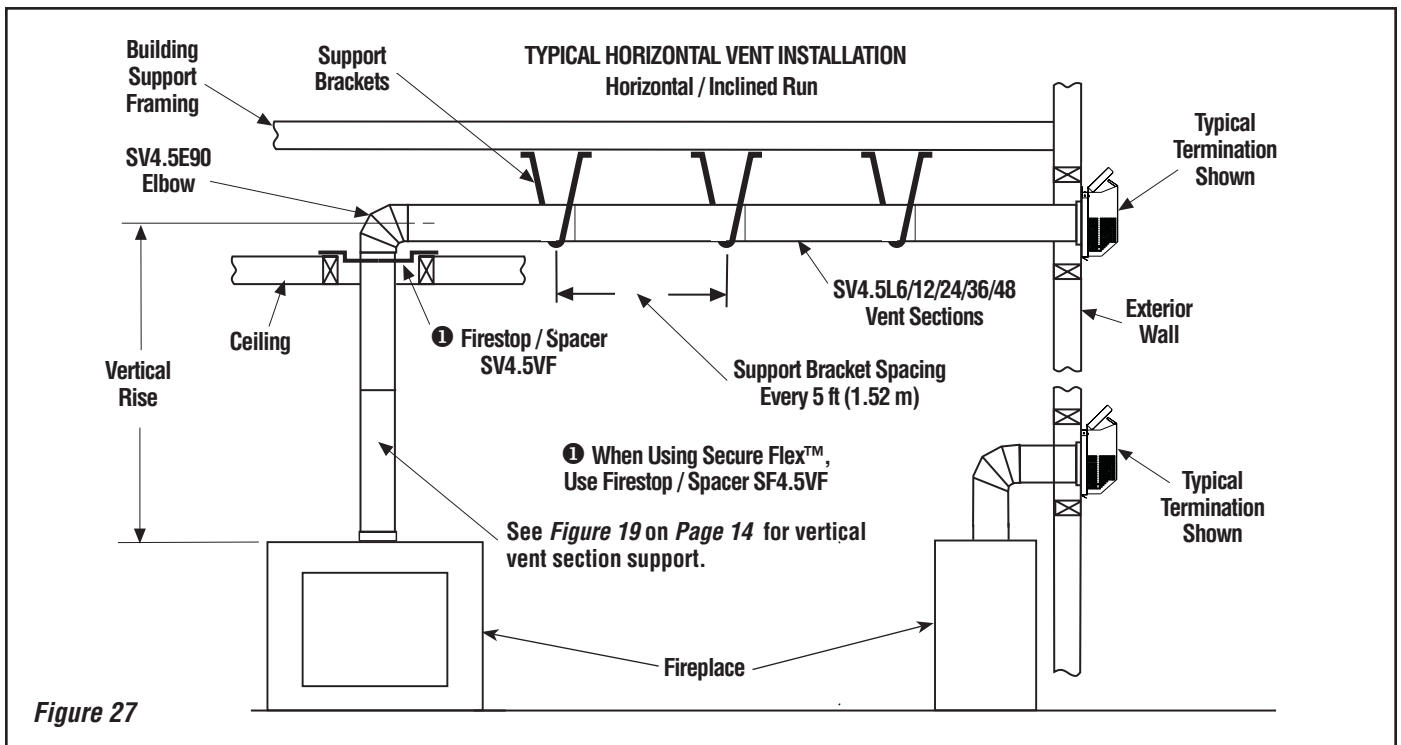

Figure 27

**D. Attach vent components to appliance** - To attach a vent component to the appliance collar, align the dimpled end over the collar, adjusting the radial alignment until the four locking dimples are aligned with the inlets of the four incline channels on the collar (see Figure 18 on Page 14).

Push the vent component against the collar until it fully engages, then twist the component clockwise, running the dimples down and along the incline channels until they seat at the end of the channels. The unitized design of the **Secure Vent™** components will engage and seal both the inner and outer pipe elements with the same procedure. Sealant and securing screws are not required.

**Note:** An elbow may not be directly attached to the appliance collar.

**E. Attach vent components to each other** - Other vent sections may be added to the previously installed section in accordance with the requirements of the vent tables. To add another vent component to a length of vent run, align the dimpled end of the component over the inclined channel end of the previously installed section, adjusting the radial alignment until the four locking dimples are aligned with the inlets of the four incline channels of the previous section.

Push the vent component against the previous section until it fully engages, then twist the component clockwise running the dimples down and along the incline channels until they seat at the end of the channels. **This seating position is indicated by the alignment of the arrow and dimple as shown in Figure 18 on Page 14.**

**F. Install firestop/spacer at ceiling** - When using **Secure Vent**, use SV4.5VF firestop/spacer at ceiling joists; when using **Secure Flex**, use SF4.5VF firestop/spacer. If there is living space above the ceiling level, the firestop/spacer must be installed on the bottom side of the ceiling. If attic space is above the ceiling, the firestop/spacer must be installed on the top side of the joist. Route the vent sections through the framed opening and secure the firestop/spacer with 8d nails or other appropriate fasteners at each corner.

**Remember to maintain 1" (25 mm) clearance to combustibles, framing members, and attic or ceiling insulation when running vertical chimney sections.**

**G. Support the vertical run sections** - See **Section E** on Page 14.

**H. Change vent direction** - At transition from or to a horizontal/inclined run, install the SV4.5E45 and SV4.5E90 elbows in the same manner as the straight vent sections.

The elbows feature a twist section to allow them to be routed about the center axis of their initial collar section to align with the required direction of the next vent run element. **Twist elbow sections in a clockwise direction only so as to avoid the possibility of unlocking any of the previously connected vent sections (see Figure 18 on Page 14).**

**I. Continue installation of horizontal/inclined sections** - Continue with the installation of the straight vent sections in horizontal/inclined run as described in **Step E**. Install support straps every 5 ft. (1.52 m) along horizontal/inclined vent runs using conventional plumber's tape.

See **Figure 27**. **It is very important that the horizontal/inclined run be maintained in a straight (no dips) and recommended to be in a slightly elevated plane, in a direction away from the fireplace of 1/4" rise per foot (20 mm per meter) which is ideal**, though rise per foot run ratios that are smaller are acceptable all the way down to at or near level.

**It is important to maintain the required clearances to combustibles: 1" (25 mm) at all sides for all vertical runs; and 3" (76 mm) at the top, 1" (25 mm) at sides, and 1" (25 mm) at the bottom for all horizontal/inclined runs.**

Use a carpenter's level to measure from a constant surface and adjust the support straps as necessary.

**J. Assemble vent run to exterior wall** - If not previously measured, locate the center of the vent at the exterior wall. Prepare an opening as described in **Step B and Figure 28**. Assemble the vent system to point where the terminus of the last section is located relative to the exterior surface to which the termination is to be attached as shown in **Figure 29 and Table 9**.

If the terminus of the last section is not within this distance, use the **telescopic vent section SV4.5LA**, as the last vent section. For wall thicknesses greater than that shown in **Figure 29**, refer to **Table 9 on Page 20**. This Table lists the additional venting components needed (in addition to the termination and adaptor) for a particular range of wall thicknesses.

**K. Attach termination adaptor** - Attach the adaptor (SV4.5RCH - provided with the termination) to the vent section or telescoping vent section), elbow or appliance collar as shown in **Figure 28** in the same manner as any SV4.5 vent component (refer to **Step E**).

**L. Install Firestop/Spacer at exterior wall** - When using the termination, install SV4.5HF (**Secure Vent™**), SF4.5HF (**Secure Flex™**) Firestop/Spacer over the opening at the exterior side of the framing, long side up, with the 3 inch spacer clearance at the top as shown in **Figure 28**, and nail into place.

(The Firestop/Spacer may also be installed over the opening at the interior side of framing).

**M. Install the Termination (SV4.5HT-2)**

For the last step, from outside the exterior wall, slide the collars of the termination onto the adaptor (the outer inside the outer and the inner outside the inner) until the termination seats against the exterior wall surface to which it will be attached. Orient the housing of the termination with the arrow pointed upwards. Secure the termination to the exterior wall. **The horizontal termination must not be recessed into the exterior wall or siding by more than the 1-1/4" (32 mm) as shown in Figure 29.**

**IMPORTANT: The vent termination is hot while in operation and for a period of time following the use of the fireplace. To prevent contact with hot surfaces, we recommend the use of a Termination Guard. See Page 37. This can be purchased at your local dealer.**

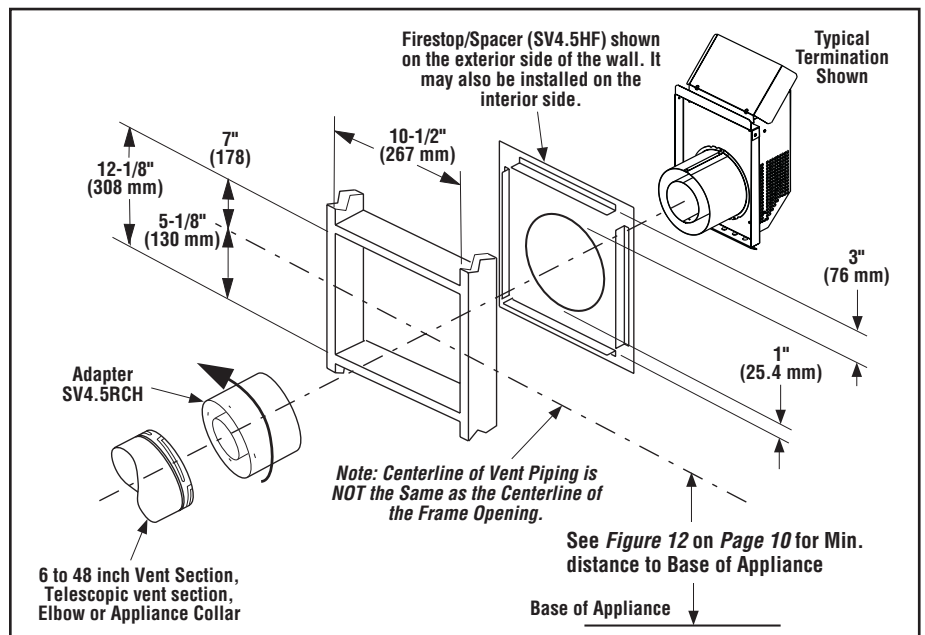

**Figure 28 - INSTALLING HORIZONTAL TERMINATION**

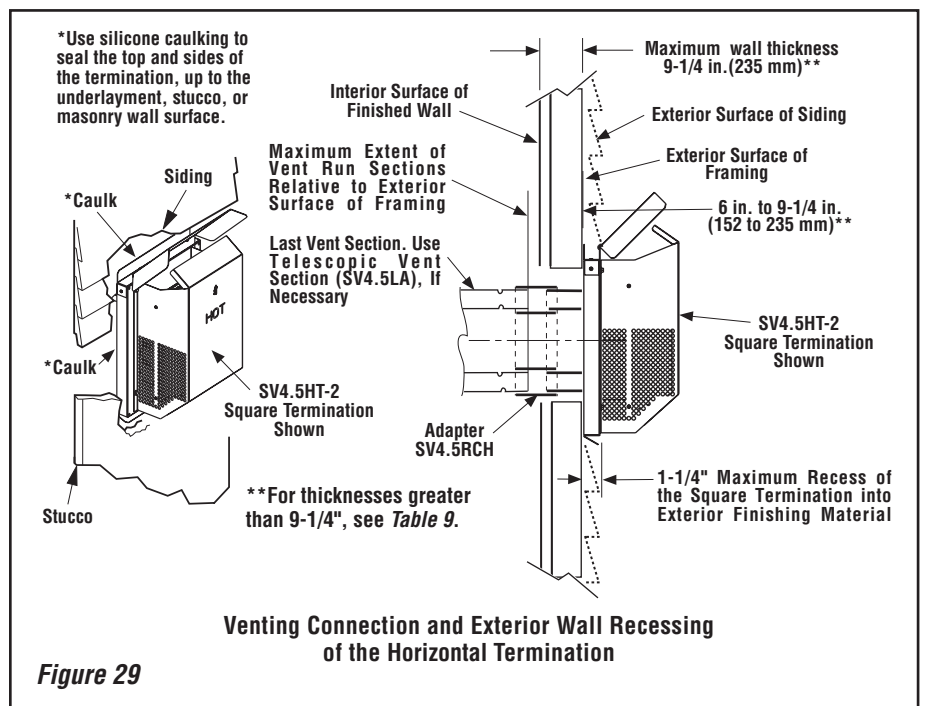

**Figure 29**

Horizontal terminations have been designed to perform in a wide range of weather conditions. Our terminations meet or exceed industry standards.

When selecting the locations of your horizontal terminations, do not place the termination where water from eaves and adjoining rooflines may create a heavy flow of cascading water onto the termination cap. If the cap must be placed where the possibility of cascading water exists, it is the responsibility of the builder to direct the water away from the termination cap by using gutters or other means.

Take care to carefully follow the installation instructions for the termination, including the use of silicone caulking where required.

NOTE: DIAGRAMS & ILLUSTRATIONS ARE NOT TO SCALE.

Use Table 9 as an aid in venting component selection for a particular range of exterior wall thicknesses.

Venting Components Required for Various Exterior Wall Thicknesses, when using Typical Termination Kits	
Vent Components Required	Exterior Wall Thickness - inches (mm)
Termination Kit Only	6 to 9-1/4 (152 to 235)
Termination Kit and 6 In. Vent Section (SV4.5L6)	10-3/4 to 14 (273 to 356)
Termination Kit and 12 in. Vent Section (SV4.5L12)	16-3/4 to 20 (426 to 508)
Termination Kit and Telescopic Section (SV4.5L12)	11-3/4 to 20 (299 to 508)

**Table 9**

Note: See Figure 29 showing wall thickness range when using SV4.5HT-2 termination kit.

### HORIZONTAL VENT FIGURES/TABLES

#### Notes:

- **Secure Vent™** components (rigid vent pipe and terminal) are shown in the Figures; **Secure Flex™** components (flexible vent pipe and terminal) may also be used.
- Two 45 degree elbows may be used in place of one 90 degree elbow. The same rise to run ratios, as shown in the venting Figures for 90 elbows, must be followed if 45 degree elbows are used.
- SV4.5VF (**Secure Vent**), SF4.5VF (**Secure Flex**) firestop/spacer must be used anytime vent pipe passes through a combustible floor or ceiling. SV4.5HF (**Secure Vent**), SF4.5HF (**Secure Flex**) firestop/spacer must be used anytime vent pipe passes through a combustible wall.
- It is very important that the horizontal/inclined run be maintained in a straight (no dips) and recommended to be in a slightly elevated plane, in a direction away from the fireplace of 1/4" rise per foot (20 mm per meter) which is ideal, though rise per foot run ratios that are smaller are acceptable all the way down to at or near level.
- The tables show a 1(V) to 5(H) ratio up to a maximum horizontal run of 20 feet.
- AN ELBOW IS ACCEPTABLE AS 1 FOOT OF VERTICAL RISE.

## WARNING

Under no circumstances, may separate sections of concentric flexible vent pipe be joined together.

Table C			
H Maximum		V Minimum	
feet	(meters)	feet	(meters)
3-1/4	(0.991)	*	(0.061)
7	(2.134)	3	(0.914)
10-1/2	(3.2)	4	(1.22)
14	(4.267)	5	(1.524)
17-1/2	(5.33)	6	(1.729)
20	(6.2)	7	(2.134)
V + V <sub>1</sub> + H = 60 feet (18.3 m) Max. H = 20 feet (6.1 meters) Max.			

Example: If 20 feet of (H) horizontal vent run is needed, then 4 feet minimum of (V) vertical vent will be required.

This table shows a 1(V) to 5(H) ratio. For every 1 foot of vertical, you are allowed 5 feet of (H) horizontal run up to a maximum (H) horizontal run of 20 feet.

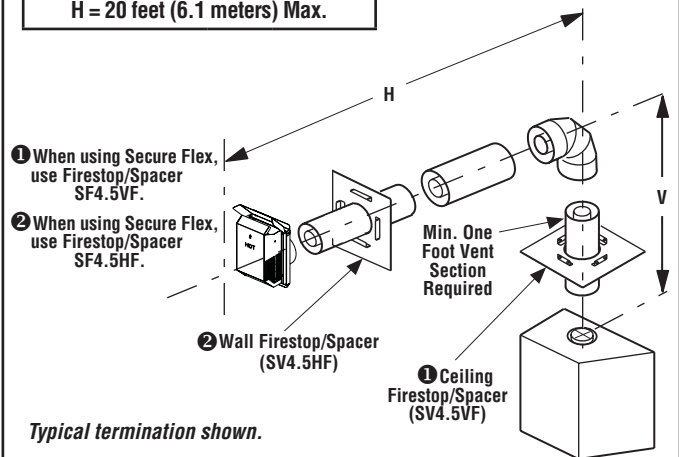

See Table 9 as an aid in venting component selection for a particular range of exterior wall thicknesses.

**Figure 30 - Top Vent - ONE 90 DEGREE ELBOW - ELBOW CONNECTION NOT DIRECTLY AT APPLIANCE**

HORIZONTAL VENT FIGURES / TABLES (CONTINUED)

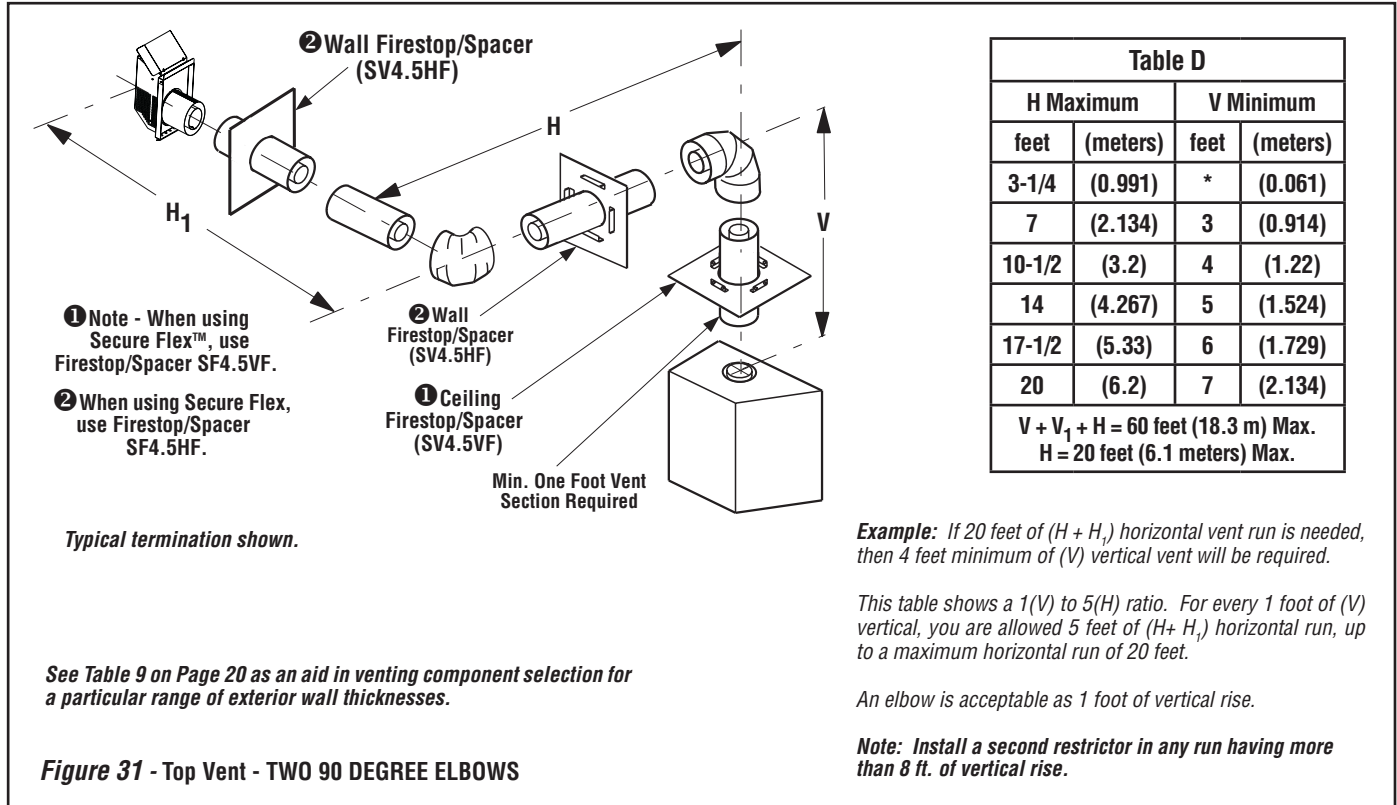



**HORIZONTAL VENT FIGURES / TABLES (CONTINUED)**

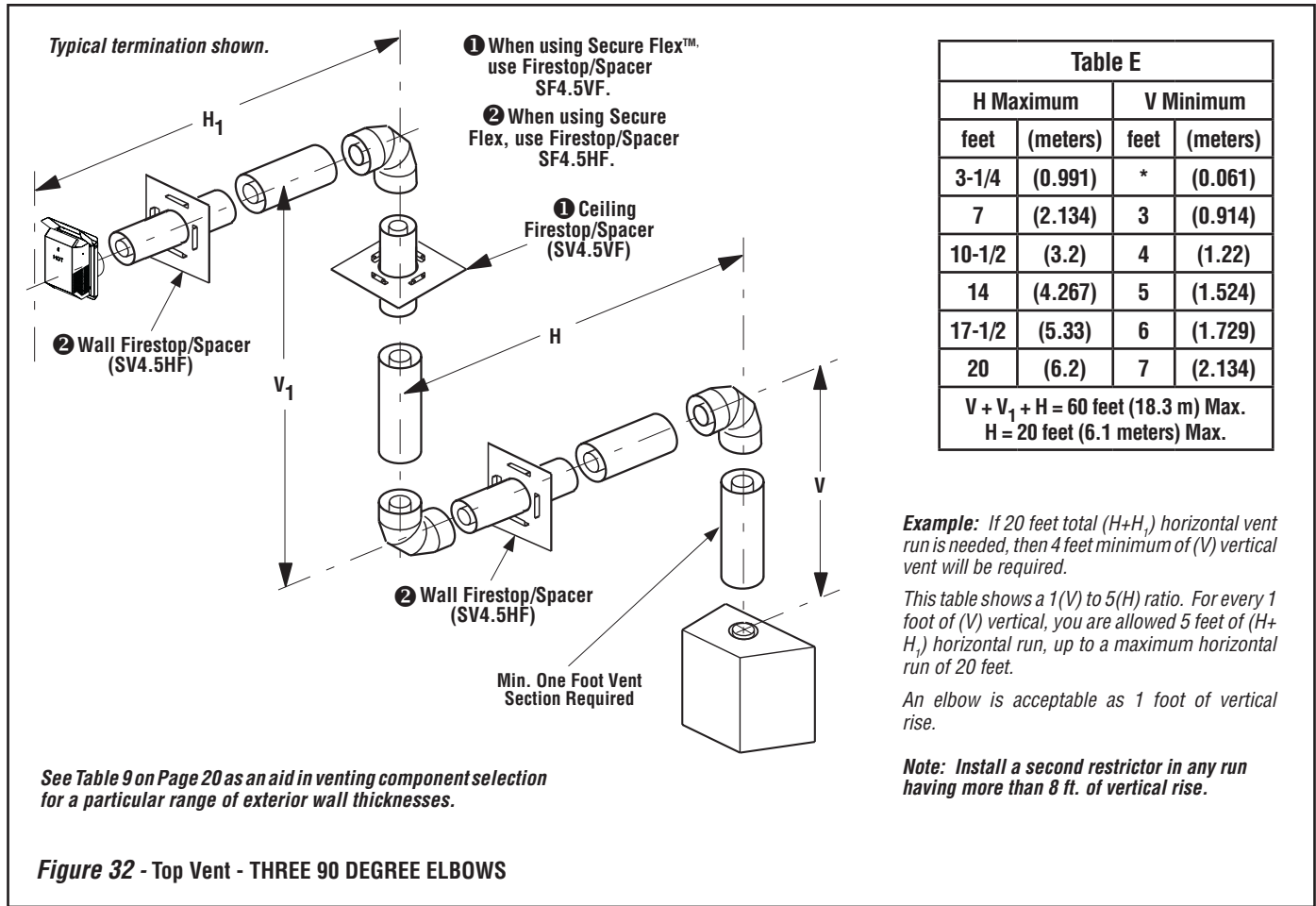

## VERTICAL OR HORIZONTAL VENTING USING **SECURE FLEX™** KITS AND COMPONENTS

**Secure Flex™** venting kits and components may be used in any venting application in place of rigid **Secure Vent™** (SV4.5) direct-vent components. All restrictions, clearances and allowances that pertain to the rigid piping apply to the flexible venting. **Secure Flexkits may not be modified; also, under no circumstances may separate sections of flex pipe be joined together.**

Using adaptor (SV4.5RF), **Secure Flex** kits may be added to the end of a vent run made up of rigid **Secure Vent** (SV4.5) vent sections provided that doing so does not violate any of the venting length, height, routing, horizontal to vertical ratio requirements or clearance considerations detailed in this manual.

**Secure Flex** kits come with an adaptor that can be fitted to the inclined channel end of the last **Secure Vent** (SV4.5) vent section in a rigid system in the exact same fashion as any other **Secure Vent** section. Align the dimpled end of the adaptor over the previously installed section or appliance collar, adjusting the radial alignment until the four locking dimples of the adaptor are aligned with the inlets of the four incline channels of the last vent section or collar. Push on the adaptor until it fully engages, then twist the adaptor clockwise running the dimples down and along the incline channels until they seat at the end of the channels.

**Attach the flexible vent to the adaptor as follows** (see also **Figure 33**):

### A. Install the Inner Flex Pipe -

1. Install the small gear clamp loosely around the inner flexible vent pipe, push it back out of the way.
2. Apply a bead of **Mill-Pac Black (700° F) high temperature sealant - Catalog No. 10K81** to the inner adaptor collar, approximately 1/2 inch from the end.
3. Pull and extend the inner flexible vent pipe.
4. Slide the inner flex pipe over the adaptor collar. Ensure the flexible vent pipe completely engages the adaptor collar to a distance of 1 3/4 inches from the end, and that it is free from damage or tears.
5. Slide the gear clamp down and tighten it fully to secure the flexible vent to the adaptor inner collar approximately 3/4 inch from the end of the flex.
6. Install **three screws, 120 degrees apart**, through the flexible vent pipe and into the adaptor collar just below the gear clamp to provide additional security to the connection.

**Note: Outer Pipe Is Pulled Away To Show The Detail of The Inner Pipe**

**APPLY ONLY MIL-PAC BLACK HIGH TEMPERATURE SEALANT (Cat. No. 10K81) to the outside surface of both collars of the adaptor (be especially careful to fill the grooves of the outer collar to be covered by the flexible pipe) and slide flexible pipe over inner and outer adaptor collars.**

1 3/4 inch (44 mm) Flexible Pipe and Adaptor Outer Collar Overlap

Adaptor (SV4.5RF)

**Figure 33**

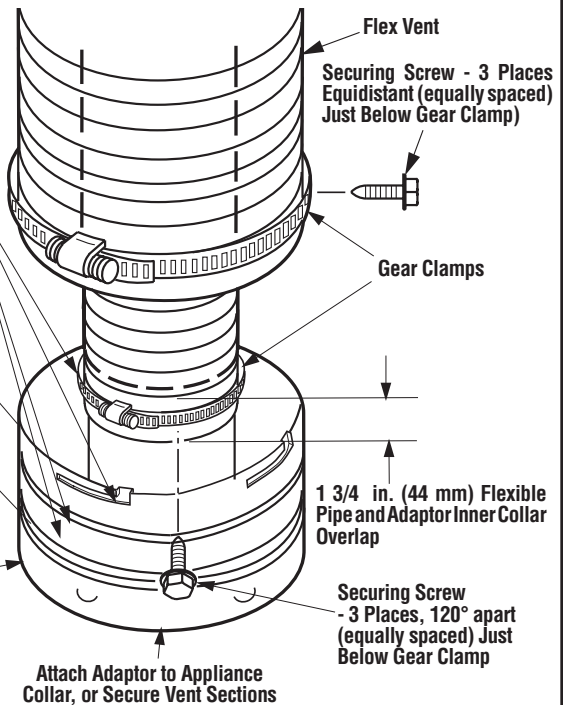

Attach Adaptor to Appliance Collar, or Secure Vent Sections

### B. Install the Outer Flex Pipe -

1. Install the large gear clamp loosely around the outer flexible vent pipe, push it back out of the way.
2. Apply a bead of **Mill-Pac Black (700° F) high temperature sealant - Catalog No. 10K81** to the outer adaptor collar; to the grooves of the collar which extend approximately 1 inch from the end and to the flat surface, approximately 1-3/8 inches from the end.
3. Pull and extend outer flexible vent pipe.
4. Slide the outer flex pipe over the adaptor collar. Ensure the flexible vent pipe completely engages the adaptor collar to a distance of 1-3/8 inches from the end, and that it is free from damage or tears.
5. Slide the gear clamp down and tighten it fully to secure the flexible vent to the adaptor outer collar approximately 3/4 inch from the end of the flex.
6. Install **three screws, 120 degrees apart**, through the flexible vent pipe and into the adaptor collar just below the gear clamp to provide additional security to the connection.

### C. Route Flex Vent -

Ensure that the flex vent is properly routed to provide the required clearance. **Do not** allow the flexible vent to bend in a radius tighter than 5" (127 mm). Refer to **Figure 34**. Space out the internal flex vent spacers evenly - approximately every 6 inches - and avoid kinking of inner pipe. Support horizontal sections of flex with metal straps at 2 foot (0.61 m) intervals.

### D. Install Firestop / Spacers at ceilings and walls

- When **Secure Flex** penetrates a wall or ceiling, a firestop / spacer is required: use the SF4.5 VF firestop / spacer for ceilings and the SF4.5 HF firestop / spacer for walls. See the appropriate sections and Figures shown throughout the venting section for their installation requirements.

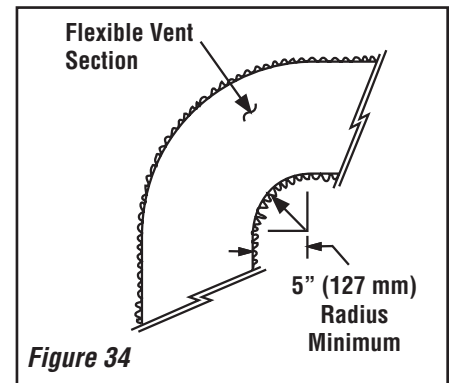

**Figure 34**

### E. Attach Flex Vent to Termination -

**Secure Flex** components can be purchased separately and attached to bulk lengths of **Secure Flex** flexible tubing cut to size at the job site. Secure the flexible vent to the **Secure Flex** terminations in the same manner (see **Figure 33**) as it was attached to the adaptor.

**Note: Secure Flex vent must be attached to Secure Flex terminations only. DO NOT substitute Secure Vent terminations or the Secure Vent adaptor for Secure Flex components. The collars of Secure Flex terminations and adaptors have a different diameter than that used with the Secure Vent pipe. Additionally, Secure Flex components have an extended length center tube for use in attaching the flexible vent.**

## Step 4. FIELD WIRING

### CAUTION

Ground supply lead must be connected to the wire attached to the green ground screw located on the outlet box. Failure to do so will result in a potential safety hazard. The appliance must be electrically grounded in accordance with local codes or, in the absence of local codes, the National Electrical Code, ANSI/NFPA 70-latest edition. (In Canada, the current CSA C22-1 Canadian Electrical Code).

**CAUTION:** Label all wires prior to disconnection when servicing controls. Wiring errors can cause improper and dangerous operation.

**ATTENTION:** Au moment de l'entretien des commandes, étiquetez tous les fils avant de les débrancher. Des erreurs de câblage peuvent entraîner un fonctionnement inadéquat et dangereux.

## Verify proper operation after servicing.

S'assurer que l'appareil fonctionne adéquatement une fois l'entretien terminé.

1. Route a 3-wire 120Vac 60Hz 1ph power supply to the appliance junction box.
2. Remove the electrical inlet cover plate from the side of the unit by removing the plate's securing screws. *See Figure 12 on page 10.*
3. Remove the cover plate's knockout and then feed the power supply wire through the knockout opening and into the unit junction box.
4. Connect the black power supply wire to the **lower outlet's** red and black pigtail leads and the white power supply wire to the **common** terminal of the outlet as shown in *Figure 35.*
5. Connect the ground supply wire to the **pigtail lead attached to outlet's green ground screw.**
6. After the wiring is complete, replace the cover plate.

**IMPORTANT:** Ground supply lead must be connected to the wire attached to the green ground screw located on the outlet box. See *Figure 35.* Failure to do so will result in a potential safety hazard. The appliance must be electrically grounded in accordance with local codes or, in the absence of local codes, the National Electrical Code, ANSI/NFPA 70-(latest edition). (In Canada, the current CSA C22-1 Canadian Electrical Code.)

7. Acquire and locate a standard junction box on the wall adjacent to the Symmetry appliance within the reach of the remote system umbilical cord wiring harness. Position the 14 pin terminal within the junction box in preparation for its attachment to the remote receiver.
8. When wall finish is complete install the receiver in the previously located junction box and connect the 14 pin terminal to the 14 pin connector on the back of the receiver.
9. Install the receiver cover plate, taking care to ensure the receiver switch is properly indexed with the switch cover when aligning the components for attachments.

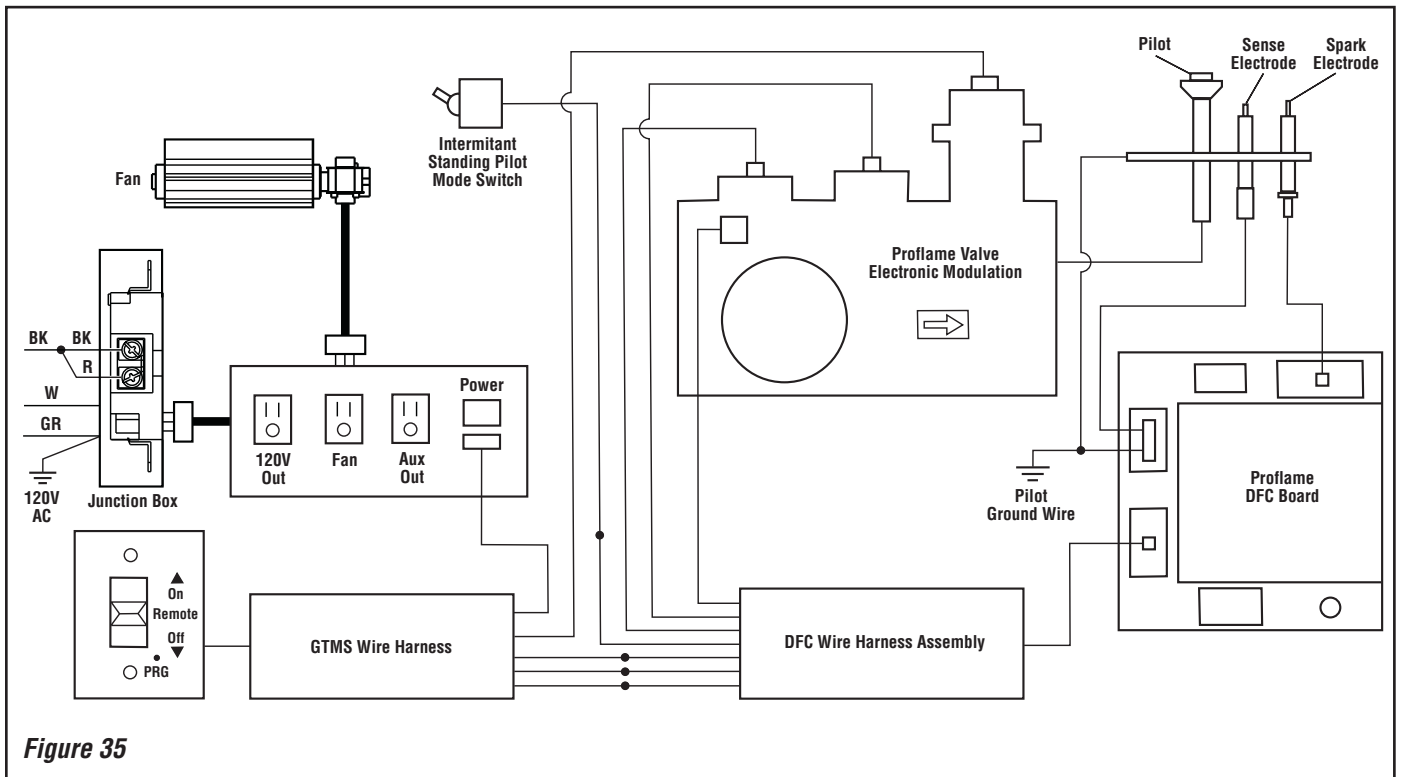

Figure 35

## Remote Control System

The Remote and Receiver allows you to command the functions of your fireplace from the comfort of your chair and is configured to control the On/Off primary burner operation, its flame levels (through six levels) and provides On/Off and Smart thermostatic control of the Symmetry appliance

The system controls fan speed through six (6) levels and has a constantly powered 120V/60Hz power outlet.

The Receiver connects directly to the gas valve, stepper motor and the Fan Control Module with an umbilical cord wiring harness.

The Receiver is powered by 4 AA type batteries, located within.

The Receiver accepts commands via radio frequency from the Transmitter and does not require line-of-sight operation.

The Receiver three position slider switch can be set to one of three positions: ON (Manual Override), REMOTE (Remote Control) or OFF.

### Initializing The System For The First Time

Install the 4 AA batteries into the receiver battery bay (behind the wall switch plate).

**Note:** The polarity of the battery and insert into the battery bay as indicated on the Battery cover (+/-).

Place the 3 position slider switch in the "Remote" position (*see Figure 35*). Using the end of a paper clip, or other similar object, insert the end of the paper clip into the hole marked "PRG" on the Receiver front cover. The Receiver will "beep" three (3) times to indicate that it is ready to synchronize with a Transmitter.

Install the 3 AAA type batteries in the Transmitter battery bay, located on the base of the Transmitter. With the batteries already installed in the Transmitter, push the ON button. The Receiver will "beep" four times to indicate the Transmitter's command is accepted and sets to the particular code of that Transmitter. The system is now initialized.

### Low Battery Power Detection

The life span of the Receiver batteries depends on various factors: quality of the batteries used, the number of ignitions of the appliance, the number of changes to the room thermostat set point, etc.

When the Receiver batteries are low, two "beeps" will be emitted from the Receiver when it receives an ON/OFF command from the Transmitter. This is an alert for a low battery condition for the Receiver. When the batteries are replaced the "beep" will be emitted from the Receiver when the ON/OFF key is pressed (See Initializing The System)

## WARNING

**Fire hazard. Can cause severe injury or death. The receiver causes ignition of the appliance. The appliance can turn on suddenly. Keep away from the appliance burner when operating the remote system or activating manual bypass of the remote system.**

## CAUTION

**Property damage hazard. Excessive heat can cause property damage. The appliance can stay lit for many hours. Turn off the appliance if it is not going to be attended for any length of time. Always place the Transmitter where children can not reach it.**

Refer to the Appliance Care & Operations manual (P/N 506025-01) for detailed remote system operation instructions.

## Step 5. CONNECTING GAS LINE

All codes require a shut-off valve mounted in the supply line. The orientation of the shut-off valve should face the front. **Figure 36** illustrates two methods for connecting the gas supply. A sediment trap is recommended in the gas piping within the home to prevent moisture and debris in the line from damaging the valve.

The flex-line method is acceptable in the U.S.A. where local codes permit, however, Canadian requirements vary depending on locality. Installation must be in compliance with local codes. These appliances are equipped with a gas flex line for use in connecting the unit to the gas line. See **Figure 36** for flex line description. The flex line is rated for both natural and propane gas. A manual shut off valve is also provided with the flex line.

The gas control valve is located in the lower control compartment.

Access the valve compartment by removing the lower control compartment panel (see **Figure 37**) by lifting and pulling the panel forward. The panel is mounted on supporting tabs at the extreme right and left hand sides. Engage the tabs into the reliefs in the panel.

The millivolt and electronic control valve has a 3/8" (10 mm) NPT thread inlet port.

**Secure all joints tightly using appropriate tools and sealing compounds (ensure propane resistant compounds are used in propane applications). It is recommended to seal around the gas line to prevent cold air leakage.**

These appliances come from the factory with the gas line access plate installed. As designed, the glass door needs to be opened to access the open gas access area. Route a hard pipe from the left to a spot directly below the access plate opening.

To access the gas line, remove the lower control compartment panel, remove the front glass enclosure panel, remove the burner and, remove the sub-floor.

Acquire the shut-off valve and gas flex line and pull the assembly forward, out of the compartment. Separate the shut-off valve from the gas flex line. Determine the length of pipe needed to route the gas line from the last fitting to a point directly below the access plate opening.

### GAS CONNECTION

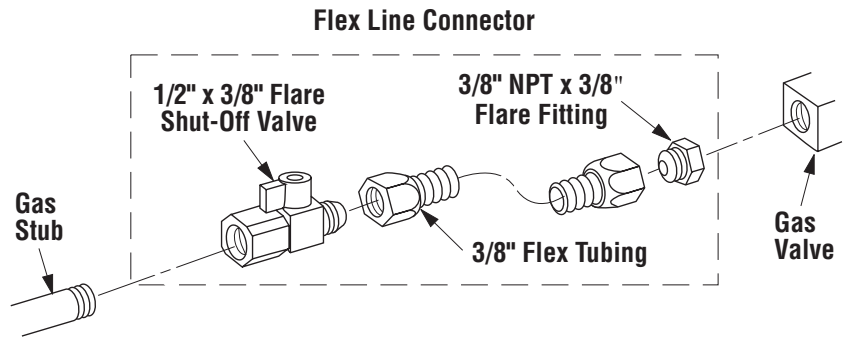

**Figure 36**

*Note: The gas supply line must be installed in accordance with building codes by a qualified installer approved and/or licensed as required by the locality. In the Commonwealth of Massachusetts, installation must be performed by a licensed plumber or gas fitter.*

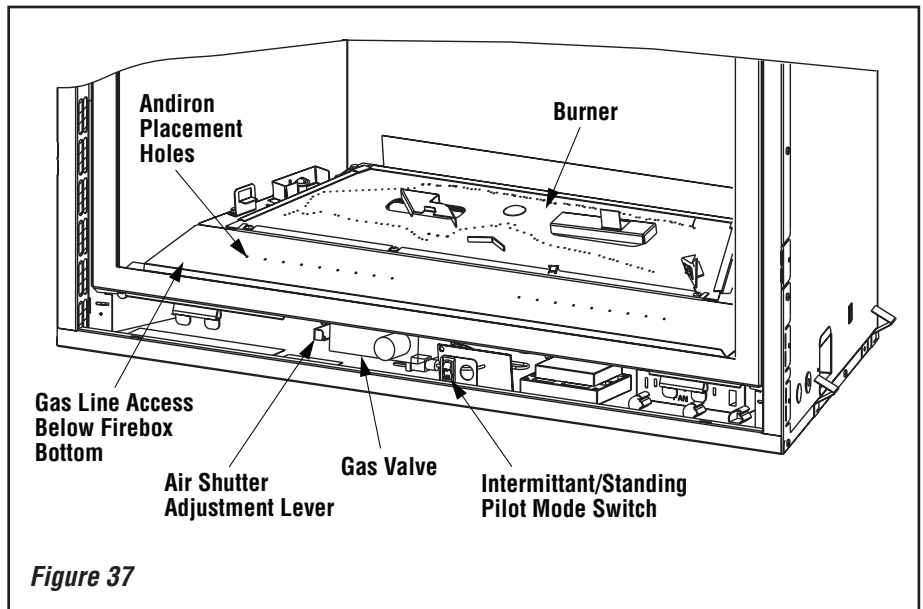

**Figure 37**

Using pipe-dressing materials appropriate for the gas type, securely affix the shut-off valve to this determined pipe length at a convenient location **outside** of the appliance lower control compartment.

Refer to **Figure 38** and insert the last length of gas pipe with its attached shut-off valve into the lower control compartment, and pass it through the gas line access hole on the left side of the appliance outer wrapper.

Using appropriate materials for the gas type, thread the last length of pipe into the end of the gas vent run and tighten in place using a pipe wrench *external* to the appliance *between* the appliance outer wrapper and the framing.

**Important: Turn the last piece of gas pipe in the last fitting until the shut-off valve is positioned in a way that allows the shut-off valve handle to be accessed in the lower control compartment, easily operated throughout its full range of motion.**

Bring the flex line to the shutoff valve by hand and align the flare fittings. Tighten the fittings by hand, and then use wrench to tighten completely, 1/4 turn at a time.



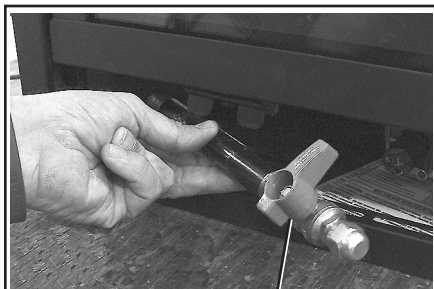

Length Of Pipe With Attached Shut-Off Valve

Figure 38

**TEST ALL CONNECTIONS FOR GAS LEAKS (FACTORY AND FIELD):**

**! WARNING**

**Never use an open flame to check for leaks.**

Turn on gas supply and test for gas leaks, using a gas leak test solution (also referred to as bubble leak solution).

*Note: Using a soapy water solution is an effective leak test solution but it is not recommended, because the soap residue that is left on the pipes/fittings can result in corrosion over time.*

- A. Light the appliance (refer to the lighting instructions label in the control compartment or in the Care and Operation Instructions manual).
- B. Brush all joints and connections with the gas leak test solution to check for leaks. If bubbles are formed, or gas odor is detected, turn the gas control knob (off/pilot/on) to the "OFF" position. Either tighten or refasten the leaking connection, then retest as described above.
- C. When the gas lines are tested and leak free, be sure to rinse off the leak testing solution.

**Step 6. VERIFYING APPLIANCE OPERATION**

With gas line installed run initial system checkout before closing up the front of the unit. Follow the pilot lighting instructions provided in the Care and Operation Instructions manual.

*Note: Lighting Instructions are also found on the literature tag tied to the gas piping next to the gas valve. To access the tag, open the lower control compartment door (Figure 45 on Page 32) by pulling the panel forward.*

When first lighting the appliance, it will take a few minutes for the line to purge itself of air. Once purging is complete, the pilot and burner will light and operate as indicated in the instruction manual. Subsequent lighting of the appliance will not require such purging. Inspect the pilot flame (remove logs, if necessary, handling carefully).

**Appliance Checkout**

To light the burner, turn 'ON' the receiver switch or the optional remote control. Ensure the ignitor lights the pilot. The pilot flame should engulf the flame rod as shown in Figure 39.

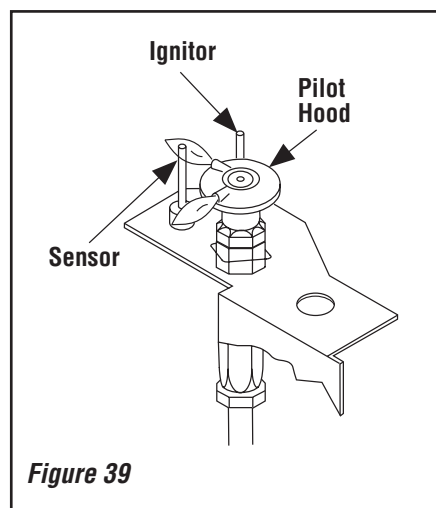

Figure 39

**Step 7. INSTALL VOLCANIC STONE, GLOWING EMBERS AND LOGS**

*NOTE: Turn off all electricity to the appliance before you install volcanic stone, embers and logs.*

*Note: The log set and fire are artistically arranged to provide a random asymmetric look to the fire. The fire intentionally does not burn in the left rear quarter of the log set.*

Carefully position the ceramic fiber logs and twigs over the burner as shown in Figures 42 (SYM-35), 43 (SYM-40) or 44 (SYM-45).

These fires are designed to provide a rich orange/red glow on the logs. If the logs are being installed for the first time, the following paragraphs apply:

DO NOT attempt to install the logs until the appliance installation has been completed, the gas line connected and tested for leaks and the initial burner operation has been checked out.

**Step 1. Remove the front glass enclosure panel** (see Removing and Installing Glass Enclosure Panels on Page 32).

**Step 2.** Cut and remove the nylon strapping securing the log set inside the fireplace.

**Step 3.** Remove the logs from their packaging. **Handle logs carefully to prevent breakage.**

Place the required ceramic fiber panels in the interior of the firebox. Follow the instructions accompanying the panels.

## LOG AND GLOWING EMBER PLACEMENT

**Step 1.** Follow the log placement instructions exactly. Refer to **Figures 42, 43 and 44** for detailed log placement instructions.

**Step 2.** Separate the Glowing Ember (Rockwool) into pieces about the size of a nickel (see **Figure 40**). Keep the pieces fluffed up with torn edges and not matted. Distribute these pieces over the burner as shown in **Figure 41**. Do not use more than necessary. When properly positioned, the Glowing Embers may cover the entire burner in front of the front ports. Do not place embers on main ports in front of the rear log.

**Note:** Position andirons and secure to the sub-floor before placing volcanic stone and vermiculite.

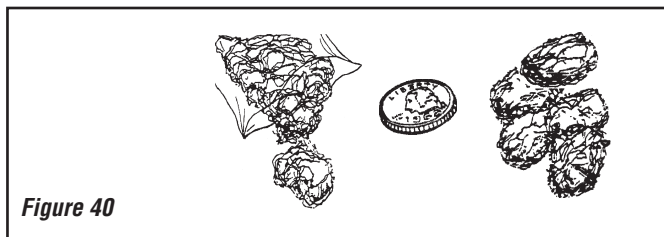

Figure 40

Rear Log (Sym-45 shown) Resting On Two Rear Log Tabs



Front Left  
Log Tab

Spread Glowing  
Embers (Rockwool)  
On Burner As Shown

Front Right  
Log Tab

Figure 41

**Step 3.** Place a mixture of volcanic stone and vermiculite generously in front of the burner on the ramped sub-floor. In an artistic manner, blend the vermiculite/volcanic stone mixture into the glowing embers in front of the log set, to simulate a diminishing ember bed.

**Note:** Excessive use of embers may result in sooting or poor flame. This appliance is provided with enough Glowing Embers for several applications, do not feel compelled to use all that is in a new bag. For best glowing effect, replace the ember material annually. Replacement Glowing Embers are available (Catalog Number 88L53).

## REFERENCE Firebox Accessories / Parts

Catalog Number	Model Number	Description
88L53	FGE	Bag of Glowing Embers
80L42	FDVS	Bag of Decorative Volcanic Stone

## ⚠ WARNING

- **DO NOT** attempt to install the logs until the appliance installation has been completed, the gas line connected and tested for leaks and the initial burner operation has been checked out.
- The size and position of the log set was engineered to give the appliance a safe, reliable and attractive flame pattern. Any attempt to use a different log set in the fireplace will void the warranty and will result in incomplete combustion, sooting, and poor flame quality.
- Logs get very hot and will remain hot up to one hour after gas supply is turned off. Handle only when logs are cool. Turn off all electricity to the appliance before you install grate, volcanic stone, vermiculite, embers and logs.
- This appliance is not designed to burn wood. Any attempt to do so could cause irreparable damage to the appliance and prove hazardous to your safety.
- If logs are not installed according to the log installation instructions, flame impingement and improper combustion could occur and result in soot and/or excessive production of carbon monoxide (CO), a colorless, odorless, toxic gas.

## SYM-35 LOG PLACEMENT

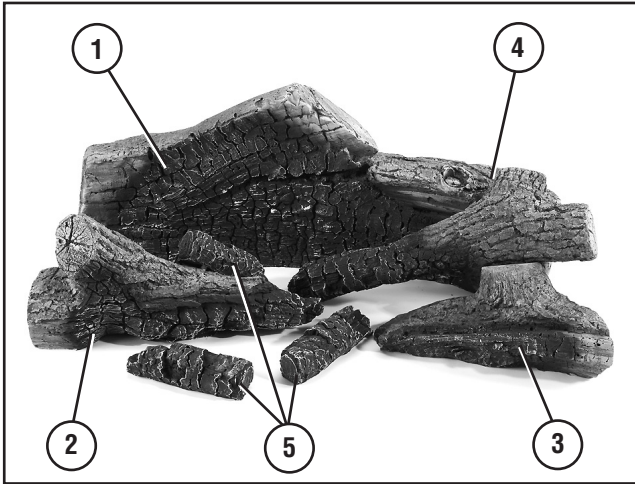

Log Number	Description
1	Rear Log
2	Bottom Left Log
3	Bottom Right Log
4	Top Right Log
5	Front Log (3)

**Catalog Number for the entire log set: H6953**

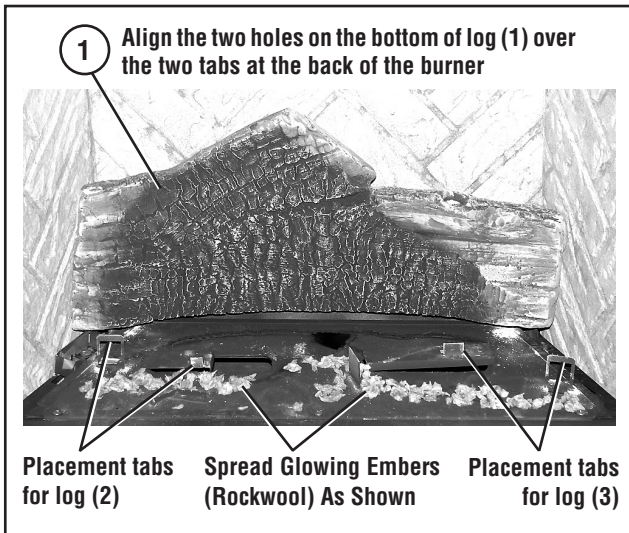

**Step 1**

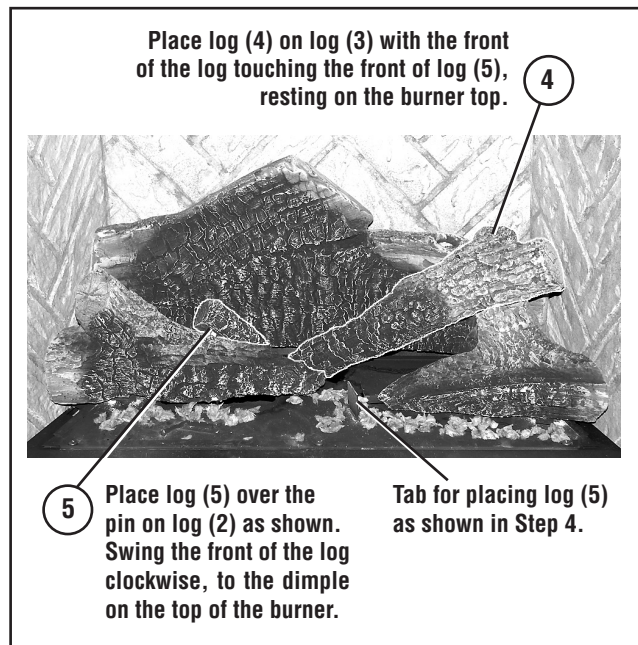

**Step 3**

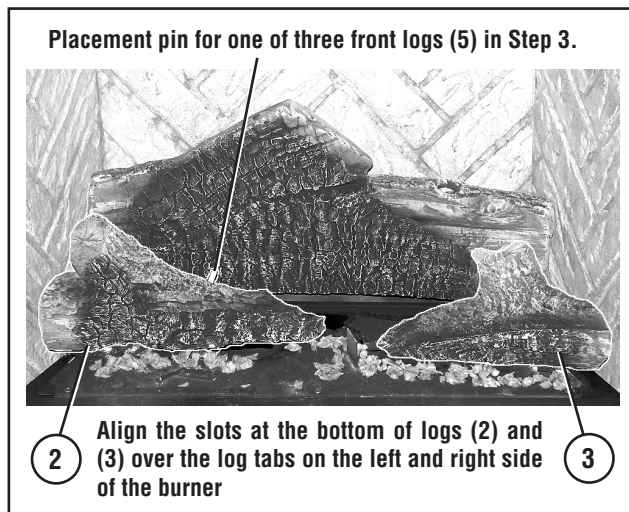

**Step 2**

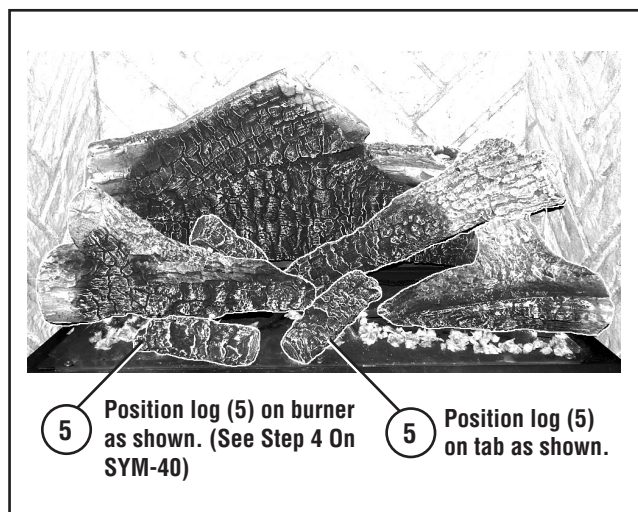

**Step 4**

**Figure 42**



## SYM-40 LOG PLACEMENT

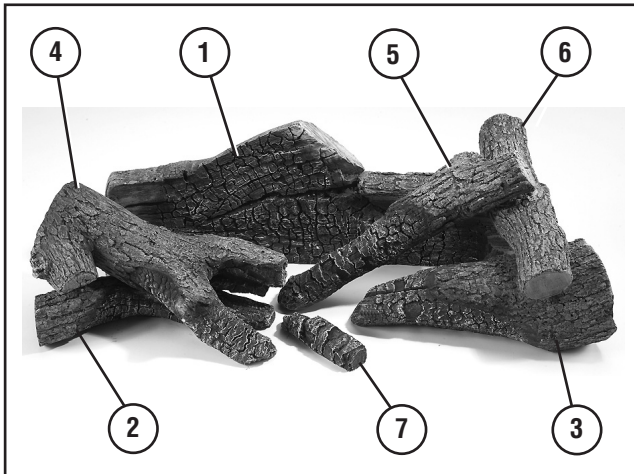

Log Number	Description
1	Rear Log
2	Bottom Left Log
3	Bottom Right Log
4	Top Left Log
5	Top Right Log
6	Top Right Cross Log
7	Front Log

**Catalog Number for the entire log set: H6956**

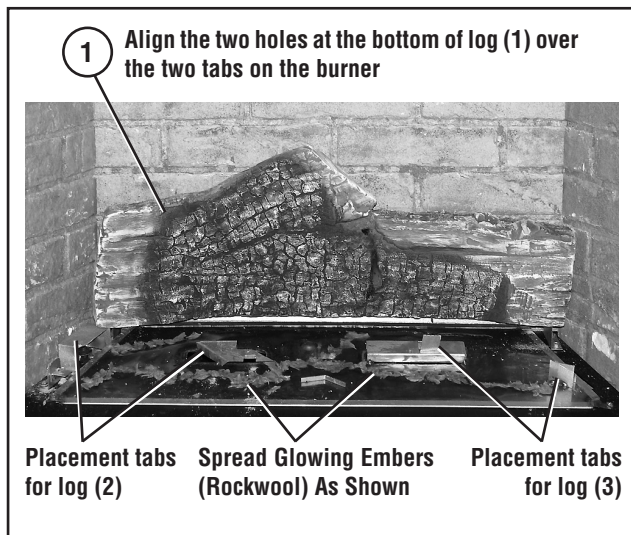

**Step 1**

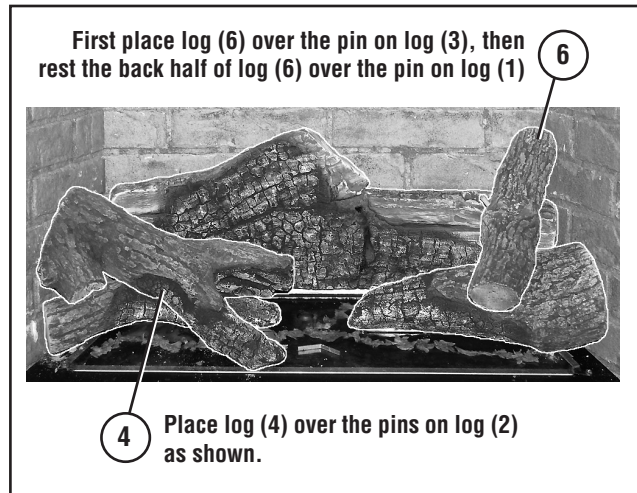

**Step 3**

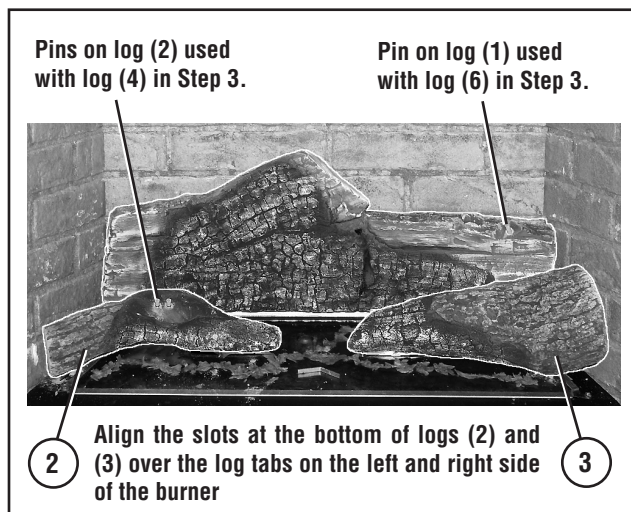

**Step 2**

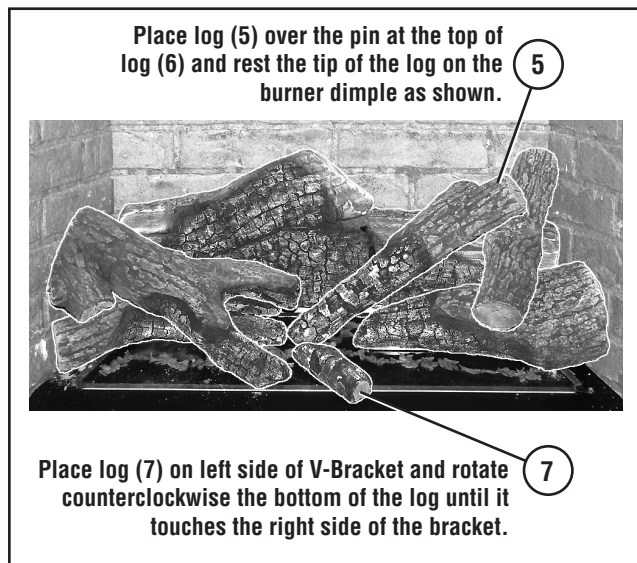

**Step 4**

**Figure 43**

## SYM-45 LOG PLACEMENT

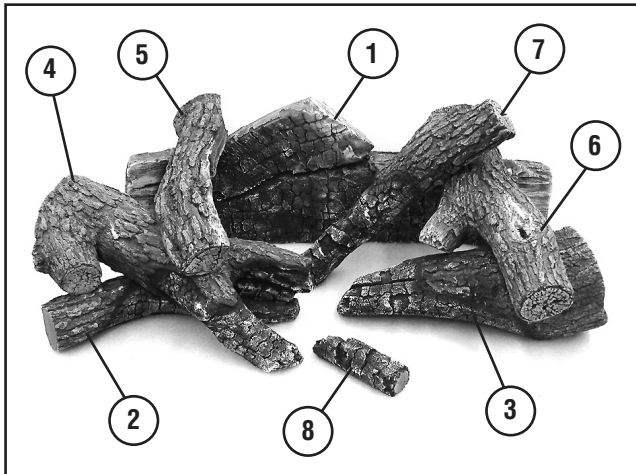

Log Number	Description
1	Rear Log
2	Bottom Left Log
3	Bottom Right Log
4	Top Left Log
5	Top Left Cross Log
6	Top Right Cross Log
7	Top Right Log
8	Front Log

**Catalog Number for the entire log set: H6959**

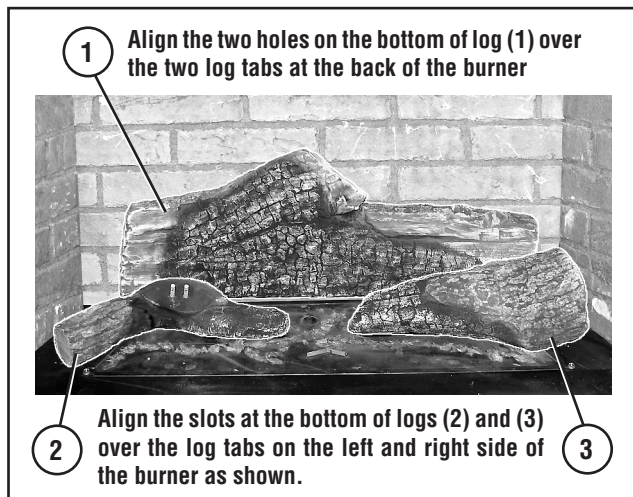

Step 1

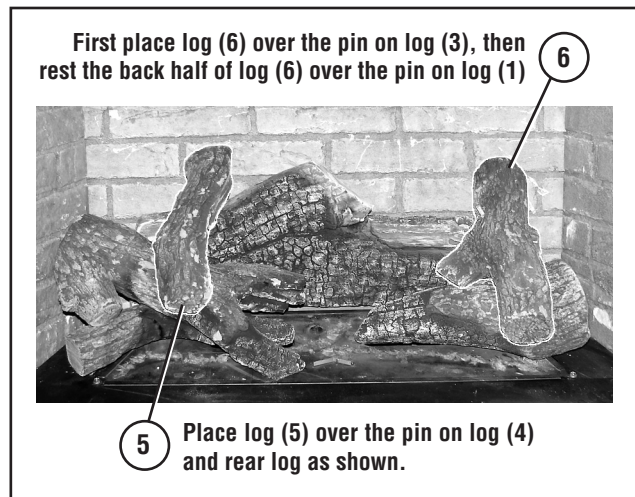

Step 3

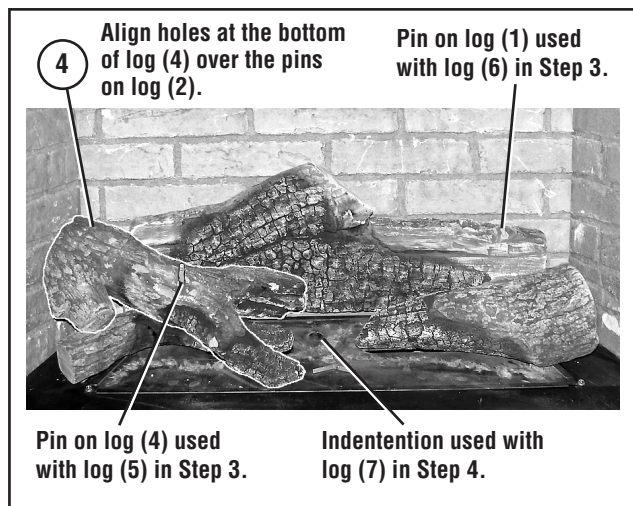

Step 2

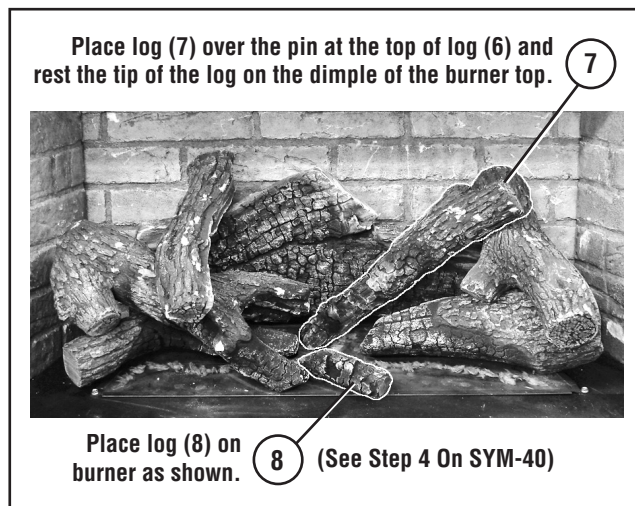

Step 4

Figure 44



## Step 8. REMOVING AND INSTALLING THE GLASS DOOR

### **! WARNING**

- Do not attempt to substitute the materials used on these doors, or replace cracked or broken glass.
- Handle this glass with extreme care! Glass is susceptible to damage – Do not scratch or handle roughly while reinstalling the glass door frame.
- The glass door(s) of this appliance must only be replaced as a complete unit as provided by the manufacturer. Do not attempt to replace broken, cracked or chipped glass separately.
- Do not attempt to touch the front enclosure glass with your hands while the fireplace is in use.

### **! WARNING**

Do not operate appliance with the glass front removed, cracked or broken.

### **! AVERTISSEMENT**

Ne pas utiliser l'appareil si le panneau frontal en verre n'est pas en place, est craqué ou brisé.

Only doors certified with the appliance shall be used.

Seules des portes certifiées pour cet appareil doivent être utilisées.

**CAUTION: DO NOT** abuse glass door by striking or slamming shut.

1. To access the glass door securing latches, first open the lower control compartment door (*Figure 45*) by lifting and pulling the bottom panel forward.

2. Pull the latches forward and down to release them from the door channel.
3. Pull the bottom of the door out a few inches and grasp it on the right and left. Gently lift to release the door from its channel above the door. Pull the door forward.
4. Retrieve the glass door. Visually inspect the gasket on the backside of the frame. Gasket surface must be clean, free of irregularities and seated firmly.
5. Inspect the gasket for defects. Insure it is properly located. Make sure the bead is not rolled up into the channel at the top of the door, but remains flat against the top of the glass (see *Figure 45*).
6. Position the door in front of the firebox opening with the bottom of the door held away from the fireplace (*Figure 45*). Hook the top flange of the door frame over the top of the firebox frame.
7. Let the bottom of the door frame swing gently in towards the fireplace ensuring that the gasket seats evenly as the door frame draws shut. Fasten the two latches located underneath the firebox floor to the door's vee-flange. Close both the latches securely.
8. Install the hood. Note the location of the three clips inside the top air channel above the door. The clips are equally spaced on the top surface of the air channel opening. Use a screwdriver to open the clips slightly if needed. Engage the back edge of the eyebrow into the clips to secure.

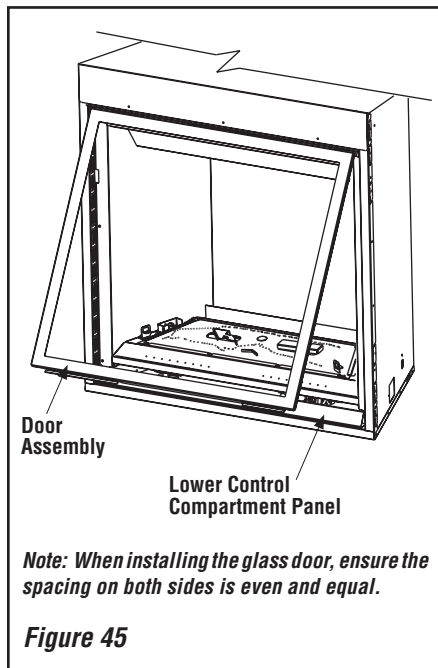

**Figure 45**

NOTE: DIAGRAMS & ILLUSTRATIONS ARE NOT TO SCALE.

## Step 9. BURNER ADJUSTMENTS

### Flame Appearance and sooting

Proper flame appearance is a flame which is blue at the base and becomes yellowish-orange in the body of the flame.

When the appliance is first lit, the entire flame may be blue and will gradually turn yellowish-orange during the first 15 minutes of operation. If the flame remains blue, or if the flame is orange with evidence of sooting (black tip), the air shutter opening may need to be adjusted.

If the air shutter opening (*Figure 49* on page 34) is closed too far, sooting may develop. Sooting is indicated by black puffs developing at the tips of very long orange flames. Sooting results in black deposits forming on the logs, appliance inside surfaces and on exterior surfaces adjacent to the vent termination.

Sooting is caused by incomplete combustion in the flames and lack of combustion air entering the air shutter opening. To achieve a warm yellowish-orange flame with an orange body that does not soot, the shutter opening must be adjusted between these two extremes.

### Air Shutter Adjustment Guidelines

- If there is smoke or soot present, first check the log set positioning to ensure that the flames are not impinging on any of the logs. If the log set is properly positioned and a sooting condition still exists, then the air shutter opening should be increased.
- The more offsets in the vent system, the larger the air shutter opening will need to be.
- An appliance operated with the air shutter opened too far, may have flames that appear blue and transparent. These weak, blue and transparent flames are termed anemic.
- Propane models may exhibit flames which candle or appear stringy. If this is present and persists, adjust the air shutter to a more closed position, then operate the appliance for a few more minutes to ensure that the flame normalizes and the flames do not appear sooty.

The following chart is provided to aid you in achieving the correct air shutter adjustment for your installation.

Air Shutter Adjustment Guidelines:		
Amount of Primary Air	Flame Color	Air Shutter Adjustment
If air shutter is closed too far →	Flame will be orange →	Air shutter gap should be increased
If air shutter is open too far →	Flame will be blue →	Air shutter gap should be decreased

## Burner Air Shutter Adjustment Procedure

### WARNINGS

- Air shutter adjustment should only be performed by a qualified professional service technician.
- Ensure front glass panel are in place and sealed during adjustment.

### CAUTIONS

- Soot will be produced if the air shutter is closed too much. Any damage due to sooting resulting from improperly setting the air shutter is not covered under the warranty.
- The air shutter door and nearby appliance surfaces are hot. Exercise caution to avoid injury while adjusting flame appearance.

1. Locate adjustment lever and adjust air shutter to the standard setting as shown in **Figure 37** (adjustment lever is located in the lower control compartment).

**Note:** Move the adjustment rod down to decrease air and up to increase.

2. Light appliance (follow lighting procedure on lighting label in control compartment or see the Care and Operation Manual).
3. Allow the burner to operate for at least 15 minutes while observing the flame continuously to ensure that the proper flame appearance has been achieved (see **Figures 46** through **48**). If the following conditions are present, adjust accordingly.
  - If flame appears weak or sooty, adjust the air shutter, incrementally, to a more open position until the proper flame appearance is achieved.
  - If flame remains blue, adjust the air shutter, incrementally, to a more closed position until the proper flame appearance is achieved.
4. When satisfied that the burner flame appearance is normal, re-install the lower control compartment door then proceed to finish the installation.



Figure 46

SYM-35



Figure 47

SYM-40



Figure 48

SYM-45

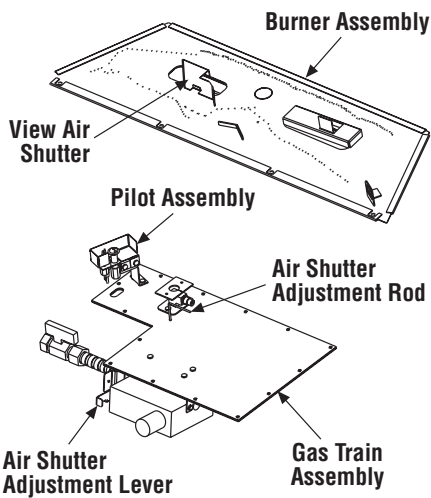

**Figure 49**

MAIN BURNER FACTORY SHUTTER OPENING SETTING		
Models	Natural Gas Inches (mm)	Propane Gas Inches (mm)
SYM-35	3/16 (4.8)	7/16 (11.1)
SYM-40	3/16 (4.8)	3/8 (9.5)
SYM-45	3/16 (4.8)	3/8 (9.5)

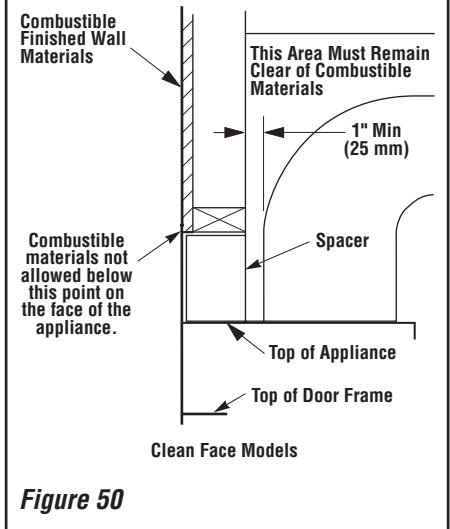

**Figure 50**

### Step 10. HOOD INSTALLATION

The hood is optional for these products. In "Shadow Box" installations, the hood may not be desired. If the opening above the door is objectionable (as is the case in certain "Flush-Mounted" installations) the hood may be used.

If desired, install the optional hood. Note the location of the three clips inside the top air channel above the door. The clips are equally spaced on the top surface of the air channel opening. Use a screwdriver to open the clips slightly if needed. Engage the back edge of the hood into the clips to secure.

### FINISHING REQUIREMENTS - Wall Details

Complete finished interior wall. To install the appliance facing flush with the finished wall, position framework to accommodate the thickness of the finished wall (**Figure 50**).

**See Page 5 for Cold Climate Insulation  
and Page 8 for Clearances**

## STEP 11. ATTACHING SAFETY-IN-OPERATION WARNINGS

It is the installers responsibility to ensure these warnings are properly affixed during installation. These warning labels are a critical step in informing consumers of safe operation of this appliance.

### ATTACHING SAFETY-IN-OPERATION WARNINGS

Your fireplace has been furnished with safety instruction labels that are to be affixed to the operation and control points of the fireplace. A safety instruction label should be affixed to the receiver wall switch plate where the fireplace is turned on and off (*See Figure A*) and the remote control handheld transmitter (*Figure B*). The warnings should already have been put in place when the fireplace initial set-up was completed. If they are not affixed at these spots, locate the multi-lingual adhesive labels provided with these instructions and proceed as follows:

1. Locate the wall receiver that controls the fireplace (verify the switch operates the fireplace by turning it on and off). Clean the wall receiver plate thoroughly to remove any dust and oils. Affix the label to the surface of the plate of the wall receiver that controls the fireplace (*Figure A*). Choose the language primarily spoken in the home.
2. Locate the remote control transmitter and clean it thoroughly to remove any dust and oils. Affix the label to the surface of handheld transmitter (*Figure B*). Choose the language primarily spoken in the home.
3. If you are unable to locate the labels, please call Lennox Hearth Products or your nearest Lennox Hearth Products dealer to receive additional safety instruction labels free of charge.

Cat. No. H8024 Replacement Label Kit

**LENNOX HEARTH PRODUCTS**  
1-800-9-LENNOX

*Note: English is red text on clear label. French and Spanish are white text on black label.*

### SAFETY LABEL DIAGRAMS



*Figure A*

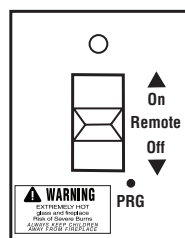

### APPOSITION DES MISES EN GARDE RELATIVES À LA SÉCURITÉ D'UTILISATION

Votre foyer a été livré avec des étiquettes de sécurité qui doivent être collées à côté des dispositifs de contrôle du foyer. Une étiquette de sécurité devrait être collée sur la plaque du récepteur mural contrôlant l'allumage du foyer (*voir Figure A*) et sur le boîtier de la télécommande (*Figure B*). Les mises en garde auraient dû être collées au moment de l'installation initiale du foyer. Si ce n'est pas le cas, prenez les étiquettes adhésives multilingues fournies avec ces instructions et procédez comme suit:

1. Repérez le récepteur mural qui contrôle le foyer (vérifiez que l'interrupteur contrôle le fonctionnement du foyer en le faisant basculer de Marche à Arrêt, et vice-versa). Nettoyez soigneusement la plaque du récepteur mural pour éliminer la poussière et les traces de graisse ou d'huile. Collez l'étiquette sur la surface de la plaque du récepteur mural qui contrôle le foyer (*Figure A*). Choisissez la langue qui est principalement parlée dans la résidence du propriétaire.
2. Repérez la télécommande et nettoyez-la soigneusement pour éliminer la poussière et les traces de graisse ou d'huile. Collez l'étiquette sur le boîtier de la télécommande (*Figure B*). Choisissez la langue qui est principalement parlée dans la résidence du propriétaire.
3. Si vous ne trouvez pas les étiquettes, veuillez appeler Lennox Hearth Products ou votre distributeur Lennox Hearth Products local pour recevoir gratuitement des étiquettes supplémentaires.

Étiquettes de remplacement, n° cat. H8024

**LENNOX HEARTH PRODUCTS**  
1-800-9-LENNOX

*Remarque : Le texte anglais est rouge sur un support transparent. Le texte français et espagnol est blanc sur un support noir.*

### DIAGRAMMES DES ÉTIQUETTES DE SÉCURITÉ



*Figure B*



### COLOCACIÓN DE ADVERTENCIAS DE SEGURIDAD EN OPERACIÓN

Su chimenea incluye etiquetas de instrucciones de seguridad que deben colocarse en los puntos de operación y control de la chimenea. Se debe colocar una etiqueta de instrucciones de seguridad en la placa del interruptor de pared del receptor desde el cual se enciende y se apaga la chimenea (*ver la Figura A*) y en el transmisor de control remoto (*Figura B*). Las advertencias ya deben haberse colocado cuando se completó la instalación inicial de la chimenea. Si no están colocadas en estos lugares, encuentre las etiquetas adhesivas multilingües proporcionadas con estas instrucciones y prosiga de la siguiente manera:

1. Identifique el receptor de pared que controla la chimenea (verifique que el interruptor opera la chimenea encendiéndola y apagándola). Limpie bien la placa del receptor de pared para quitar el polvo y aceite. Pegue la etiqueta en la superficie de la placa del receptor de pared que controla la chimenea (*Figura A*). Seleccione el idioma que más se habla en la casa.
2. Identifique el transmisor de control remoto y límpielo bien para quitar el polvo y aceite. Pegue la etiqueta en la superficie del transmisor (*Figura B*). Seleccione el idioma que más se habla en la casa.
3. Si no puede encontrar las etiquetas, sírvase llamar a Lennox Hearth Products o al distribuidor de Lennox Hearth Products más cercano para recibir etiquetas de instrucciones de seguridad adicionales gratuitas.

Juego de etiquetas de repuesto - N° de cat. H8024

**LENNOX HEARTH PRODUCTS**  
1-800-9-LENNOX

*Nota: La etiqueta en inglés es transparente con texto rojo. Las etiquetas en francés y español son negras con texto blanco.*





### DIAGRAMAS DE ETIQUETAS DE SEGURIDAD



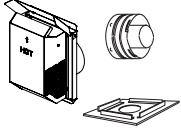

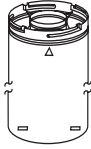
## INSTALLATION ACCESSORIES

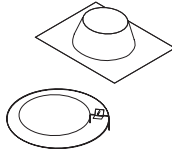
Listed Secure Vent™ Components			
	Cat. No.	Model	Description
	H1968	SV4.5HT-2	Horizontal Square Termination With Firestop / spacer (H2246) & Adaptor (74L61)

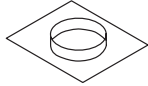
	Cat. No.	Model	Description
Vent Sections (Rigid) 	77L70	SV4.5L6	6 Inch (152 mm)
	77L71	SV4.5L12	12 Inch (305 mm)
	77L72	SV4.5L24	24 Inch (610 mm)
	77L73	SV4.5L36	36 Inch (914 mm)
	77L74	SV4.5L48	48 Inch (1219 mm)
	77L75	SV4.5LA	Telescopic Length Slip Section (2" to 7-1/2" rigid)
	77L76	SV4.5E45	45 Degree Elbow
	77L77	SV4.5E90	90 Degree Elbow
The following flashings come packaged with a storm collar:			
	77L78	SV4.5F	Flat Roof Flashing
	77L79	SV4.5FA	1/12 to 7/12 Adjustable Flashing
	77L80	SV4.5FB	7/12 to 12/12 Adjustable Flashing
	77L81	SV4.5SC6	Storm Collar (6 per box)
	H6183	SV4.5HF5	Firestop Spacer, 5", <b>rigid</b>
	H6184	SF4.5HF5	Firestop Spacer, 5", <b>flex</b>
	H2246	SV4.5HF-10	Firestop / Spacer-Horizontal, <b>rigid</b> (3-1-1 spacing), 10 Pack
	H2247	SV4.5VF-10	Firestop / Spacer-Vertical, <b>rigid</b> (1-1-1 spacing), 10 Pack
	96K92	SV4.5SP	Support Plate



**INSTALLATION ACCESSORIES CONTINUED**

Listed Secure Vent™ Components			
	Cat. #	Model	Description
	17M52	SV4.5HGS-1	Termination Guard, Square (1 pack) <i>Ref. instructions #750,109M</i>
	17M53	SV4.5HGS-12	Termination Guard, Horizontal Square (12 pack) <i>Ref. instr. #750,109M</i>
	87L02	SV4.5HGS	Termination Guard for Horizontal Square Termination (Deluxe) (1 pack) <i>Ref. instr. #750,055M</i>
	H5820	SV4.5HTSK	Termination Shroud (Guard) for Horizontal Square Termination (1 pack) ( <i>ref. instr. #750246M</i> )
	H5816	SV4.5-TWSK10	Through Wall Shield Kit (used to shield the direct-vent pipe from blown insulation) <i>Ref. instr. #750,247M</i>
	H3907	SV4.5ARSA	Attic Insulation Shield w/ adjustable height, 12"-22"
	96K93	SV4.5SU	Support Strap
	10K81	SFMP	Mill-Pac, Black, High Temperature Sealant
	89L40	SFMP-12	Mill-Pac, Black, High Temperature Sealant - Bulk 12 pack
	99L02	SV4.5HRK14	Horizontal Riser Kit, 14", <i>Ref. instr. #750,146M</i>
	99L03	SV4.5HRK36	Horizontal Riser Kit, 36", <i>Ref. instr. #750,146M</i>
	H1988	CTSA-33	Chase Top Shroud Kit, Arch Top 3 X 3 Ft., <i>Ref. instr. #750,194M</i>
	H1985	CTSO-33	Chase Top Shroud Kit, Open Top 3 X 3 Ft., <i>Ref. instr. #750,193M</i>
	H1987	CTSO-44	Chase Top Shroud Kit, Open Top 4 X 4 Ft., <i>Ref. instr. #750,193M</i>
	H1986	CTSO-46	Chase Top Shroud Kit, Open Top 4 X 6 Ft., <i>Ref. instr. #750,193M</i>

**Listed Secure Flex™ Components**

These termination kits include firestop/spacer, gear clamps and flex adaptor.

	60L10	SF-18	18 feet (5.49 m) * compressed <b>flex</b> , <i>Ref. instr. #750,053M</i>
	98K03	SF-12	12 feet (3.66 m) * compressed <b>flex</b> , <i>Ref. instr. #750,052M</i>
	H2248	SF4.5HF-10	Firestop / Spacer - Horizontal, <b>flex</b> (3-1-1 spacing), 10 Pack
	H2249	SF4.5VF-10	Firestop/Spacer-Vertical, <b>flex</b> (1-1-1 spacing), 10 Pk

	Cat. #	Model	Description
	H1969	SF4.5HT-2	Horizontal Square Termination for <b>flex</b> (without flex)
	77L87	SFKIT12S	Square Term. for <b>flex</b> (with 12 inch [305 mm] * compressed flex)
	77L88	SFKIT18S	Square Term. for <b>flex</b> (with 18 inch [457 mm] * compressed flex)
	77L89	SFKIT24S	Square Term. for <b>flex</b> (with 24 inch [610 mm] * compressed flex)
	77L90	SFKIT36S	Square Term. for <b>flex</b> (with 36 inch [914 mm] * compressed flex)
	77L91	SFKIT48S	Square Term. for <b>flex</b> (with 48 inch [1219 mm] * compressed flex)
	56L74	SFVT30	Vertical Termination for <b>flex</b> (flat to 6/12) with flex adaptor, section of rigid vent, roof support collar assembly, roof flashing and storm collar. <i>Ref. instr. #750,052M</i>
	56L75	SFVT45	Vertical Termination for <b>flex</b> (6/12 to 12/12) with flex adaptor, section of rigid vent, roof support collar assembly, roof flashing and storm collar. <i>Ref. instr. #750,052M</i>
	91L66	SFGC4-6	Gear Clamp 4.5 in. (114 mm) for <b>flex</b> (6 pack)
	91L67	SFGC7-6	Gear Clamp 7.5 in. (190.5 mm) for <b>flex</b> (6 pack)
	H7748	H7748	36" <b>Flex</b> Connector Kit. 36" of flex with two adapters for mating two rigid sections of vent together.

\* All compressed flex vents can be expanded up to two times.

## GAS CONVERSION KITS

### **WARNING**

This conversion kit shall be installed by a qualified service agency in accordance with the manufacturer's instructions and all applicable codes and requirements of the authority having jurisdiction. If the information in these instructions is not followed exactly, a fire, explosion or production of carbon monoxide may result causing property damage, personal injury or loss of life. The qualified service agency is responsible for the proper installation of this kit. The installation is not proper and complete until the operation of the converted appliance is checked as specified in the manufacturer's instructions supplied with the kit. The qualified service agency performing this installation assumes responsibility for this conversion.

### **AVERTISSEMENT**

Cette trousse de conversion doit être installée par un technicien agréé, selon les instructions du fabricant et selon toutes les exigences et tous les codes pertinents de l'autorité compétente. Assurez-vous de bien suivre les instructions dans cette notice pour réduire au minimum le risque d'incendie, d'explosion ou la production de monoxyde de carbone pouvant causer des dommages matériels, des blessures ou la mort. Le technicien agréé est responsable de l'installation de cette trousse. L'installation n'est pas adéquate ni complète tant que le bon fonctionnement de l'appareil converti n'a pas été vérifié selon les instructions du fabricant fournies avec la trousse. Le fournisseur de service qualifié ayant réalisé l'installation assume les responsabilités liées à la conversion.

#### In Canada:

**THE CONVERSION SHALL BE CARRIED OUT IN ACCORDANCE WITH THE REQUIREMENTS OF THE PROVINCIAL AUTHORITIES HAVING JURISDICTION AND IN ACCORDANCE WITH THE REQUIREMENTS OF THE CAN/CSA-B149.1 INSTALLATION CODE.**

**LA CONVERSION DEVRA ÊTRE EFFECTUÉE CONFORMÉMENT AUX RECOMMANDATIONS DES AUTORITÉS PROVINCIALES AYANT JURISDICTION ET CONFORMÉMENT AUX EXIGENCES DU CODE D'INSTALLATION CAN/CSA-B149.1.**

Gas conversion kits are available to adapt your appliance from the use of one type of gas to the use of another. These kits contain all the necessary components needed to complete the task including labeling that must be affixed to ensure safe operation.

Kit part numbers are listed here and the following steps detail the conversion procedure. Refer to the instructions provided with the conversion kit when performing any gas conversion.

Natural To Propane Gas Conversion Kits	
Models	Catalog No.
SYM-35	H7749
SYM-40	H7750
SYM-45	H7751

Propane To Natural Gas Conversion Kit	
Models	Catalog No.
SYM-35	H7752
SYM-40	H7753
SYM-45	H7754

## INSTALLATION INSTRUCTIONS

**Step 1. TURN OFF THE GAS SUPPLY TO THE APPLIANCE** and disconnect power supply at the circuit breaker. Ensure appliance is cold.

**CAUTION: THE GAS SUPPLY SHALL BE SHUT OFF PRIOR TO DISCONNECTING THE ELECTRICAL POWER, BEFORE PROCEEDING WITH THE CONVERSION.**

**ATTENTION: AVANT D'EFFECTUER LA CONVERSION, COUPEZ D'ABORD L'ALIMENTATION EN GAZ, ENSUITE, COUPEZ L'ALIMENTATION ÉLECTRIQUE.**

**Step 2.** Remove the front glass door/frame (see *Figure 45*).

**Step 3.** Carefully remove the logs. **Exercise care so as not to break the logs.**

**Step 4.** Refer to *Figure 51*.

Remove the burner assembly with attached venturi tube.

### Electronic Appliances

**Step 5. SIT Systems** - Refer to *Figure 44* on **page 28** and the instructions provided with the kit. **Discard all removed components.**

**Step 6.** See *Figure 52*. Using a Torx T20, or slotted screwdriver, remove and discard the two (2) pressure regulator mounting screws, pressure regulator tower, the diaphragm assembly (A) (if applicable) and the spring (B).

**Step 7.** Ensure the rubber gasket (C), which is pre-fitted as part of the assembly, is properly positioned (see *Figure 52*).

**Step 8.** Install the new Stepper Motor pressure regulator assembly using the supplied screws as shown in **Figure 52**. Tighten screws securely (reference torque = 25 lb. in.).

**Step 9.** Install the enclosed identification label to the valve body where it can be easily seen.

**Step 10.** Make Stepper Motor and valve electrical connections.

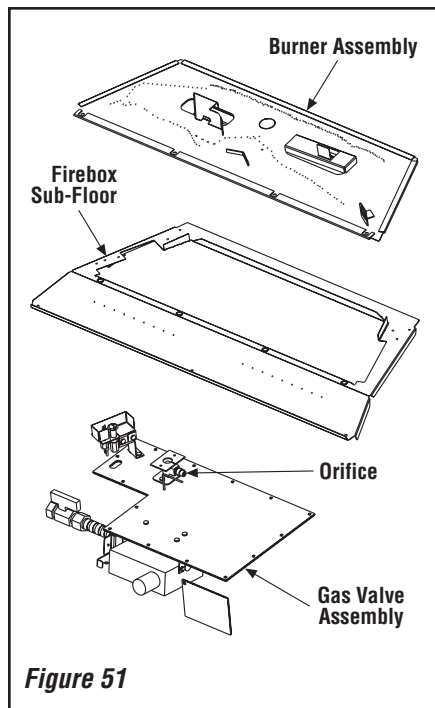
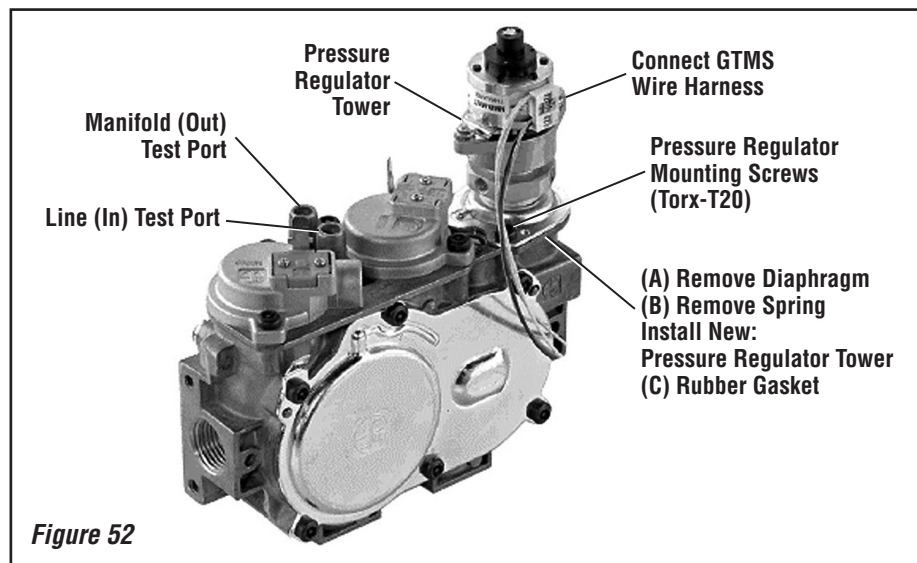

**Figure 51**

**Step 11.** Attach manometer to the manifold side pressure test fitting and verify manifold pressure reads 3.5 inches water column (0.87 kPa) for natural gas, and 10.0 inches water column (2.49 kPa) for propane gas (see **Figure 52**).

**Step 12.** See **Figure 53** and replace the pilot orifice as follows: Remove the pilot hood assembly to access the hexed pilot orifice. Remove and replace the orifice with the one provided with the kit. **Exercise extreme care to prevent damage to or breakage of the ignitor assembly.**

**Step 13.** (Refer to **Figure 51**) Remove the orifice from the manifold and replace it with the one provided in the kit. See the following table for orifice sizes for natural and propane models. **Figure 54** illustrates the orifice. Always check and verify orifice size.



**Figure 52**

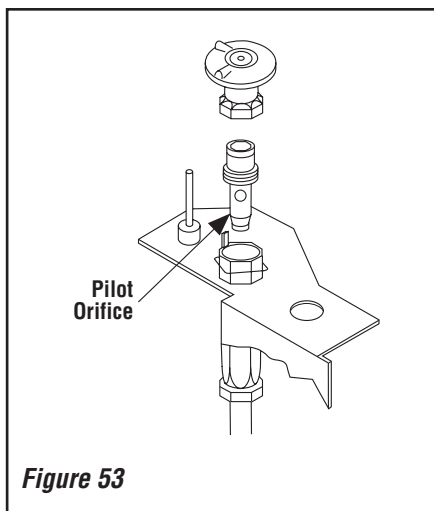

**Figure 53**

**Note:** Use pipe joint compound or Teflon tape on all pipe fittings before installing (ensure propane resistant compounds are used in propane applications, do not use pipe joint compounds on flare fittings).

**Step 14.** Reassemble the remaining components by reversing the procedures outlined in the preceding steps.

Retrieve the burner and slide the venturi tube over the orifice. Set the shutter adjusting opening as shown in **Figure 49**, page 34.

**Step 15.** Attach the conversion label provided in the conversion kit to the rating plate on the appliance.

Burner Orifice Sizes Elevation 0-4500 feet ( 0-1372 meters)		
Model Series	Nat. Gas drill size (inches)	Propane drill size (inches)
SYM-35	#35 (0.110")* 21L80•	(0.062")* 21L01•
SYM-40	#32 (0.116")* 37L82•	(0.065")* 74L88•
SYM-45	(0.119")* 39L09•	(0.068")* H7875•

**Table 10** \* Standard size installed at factory  
• Part /Cat. Number

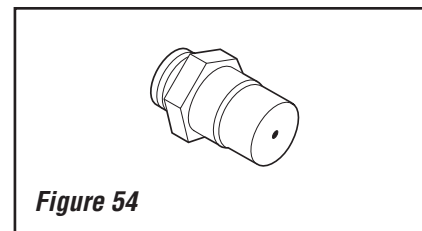

**Figure 54**

**Step 16.** Apply gas to the system and relight appliance. With the main burner "ON", test the new pressure regulator assembly for leaks using a leak test solution.

**Step 17.** Relight the main burner and verify proper burner ignition and operation.

**Always test pressure with the valve regulator control at the highest setting.**

---

Lennox Hearth Products reserves the right to make changes at any time, without notice, in design, materials, specifications, prices and also to discontinue colors, styles, and products. Consult your local distributor for fireplace code information.

LENNOX®, the LENNOX design, DAVE LENNOX, the image of DAVE LENNOX and other related LENNOX marks are registered or common law trademarks of Lennox Industries Inc. and are used with permission.

Printed in U.S.A. © 2012 Lennox Hearth Products

**P/N 506023-08 Rev. D 10/2012**



1508 Elm Hill Pike, Suite 108, Nashville, TN 37210