



INSTALLATION AND OPERATION MANUAL

Direct-Vent Gas Fireplace Heater Inserts

DAVE LENNOX
signature
COLLECTION

The Shoreline™ fireplace insert is factory equipped for 40,000 BTU input and can be converted to 33,000 using the smaller orifice provided.

Retain These Instructions For Future Reference

P/N 850,050M Rev. C, 01/2008

A French manual is available upon request. Order P/N 850,050CF. Ce manuel d'installation est disponible en français, simplement en faire la demande. Numéro de la pièce 850,050CF.

In the Commonwealth of Massachusetts:

- Installation must be performed by a licensed plumber or gas fitter
- See Table of Contents for location of additional Commonwealth of Massachusetts requirements

Tested &
Listed By
O-TL
Beaverton
Oregon USA
OMNI-Test Laboratories, Inc.
Report No. 050-F-22-5



Shoreline™ 33/40 DV INS



! WARNINGS



- **Hot! Do not touch!** The glass and surfaces of this appliance will be hot during operation and will retain heat for a while after shutting off the appliance. Severe burns may result.
- Carefully supervise children in the same room as appliance.
- If small children are present in the home, it is recommended that this appliance be fitted with a screen door or screen panel kit. See *Page 33* for ordering information.
- Suitable for installation into masonry or factory built fireplaces. These appliances may be installed in an after-market permanently located, manufactured (mobile) home (USA only), where not prohibited by local codes. This appliance is only for use with the type of gas indicated on the rating plate.
- This appliance is not convertible for use with other gases unless a certified kit is used.
- Lennox™ gas-burning appliances are designed for use as a supplemental heater. They are not intended for continuous use as a primary heat source.

WARNING: If the information in this manual is not followed exactly, a fire or explosion may result causing property damage, personal injury or loss of life.

Do not store or use gasoline or other flammable vapors or liquids in the vicinity of this or any other appliance.

WHAT TO DO IF YOU SMELL GAS:

- Do not light any appliance.
- Do not touch any electrical switch; do not use any phone in your building.
- Immediately call your gas supplier from a neighbor's phone. Follow your gas supplier's instructions.
- If your gas supplier cannot be reached, call the fire department.

Installation and service must be performed by a qualified installer, service agency or the gas supplier.

AVERTISSEMENT: Assurez-vous de bien suivre les instructions donné dans cette notice pour réduire au minimum le risque d'incendie ou pour éviter tout dommage matériel, toute blessure ou la mort.

POUR VOTRE SÉCURITÉ: Ne pas entreposer ni utiliser d'essence ni d'autre vapeurs ou liquides inflammables dans le voisinage de cet appareil ou de tout autre appareil.

POUR VOTRE SÉCURITÉ: Que faire si vous sentez une odeur de gaz:

- Ne pas tenter d'allumer d'appareil.
- Ne touchez à aucun interrupteur. Ne pas vous servir des téléphones se trouvant dans le bâtiment où vous vous trouvez.
- Evacuez la pièce, le bâtiment ou la zone.
- Appelez immédiatement votre fournisseur de gaz depuis un voisin. Suivez les instructions du fournisseur.
- Si vous ne pouvez rejoindre le fournisseur de gaz, appelez le service des incendies.

L'installation et service doit être exécuté par un qualifié installateur, agence de service ou le fournisseur de gaz.

IMPORTANT SAFETY AND WARNING INFORMATION

READ THIS MANUAL IN ITS ENTIRETY AND UNDERSTAND THESE RULES TO FOLLOW FOR SAFETY.

WARNING

Improper installation, adjustment, alteration, service or maintenance can cause injury or property damage. Refer to this manual. For assistance or additional information consult a qualified installer, service agency or the gas supplier.

WARNING

Do not attempt to alter or modify the construction of the appliance or its components. Any modification or alteration may void the warranty, certification and listings of this unit.

WARNING

Failure to comply with the installation and operating instructions provided in this document will result in an improperly installed and operating appliance, voiding its warranty. Any change to this appliance and/or its operating controls is dangerous. Improper installation or use of this appliance can cause serious injury or death from fire, burns, explosion or carbon monoxide poisoning.

1. **FOR YOUR SAFETY** do not install or operate your fireplace insert without first reading and understanding this manual. Any installation or operation of the appliance deviating from that which is stated in this manual **WILL** void the warranty and may be hazardous.
2. **INSTALLATION AND REPAIR SHOULD ONLY BE DONE BY A QUALIFIED SERVICE TECHNICIAN. DO NOT ATTEMPT TO SERVICE THE APPLIANCE YOURSELF.**
3. The insert should be inspected and cleaned before use and at least annually by a qualified service technician. More frequent cleaning may be required due to excessive lint from bedding material, carpeting, etc.
4. It is imperative that control compartments, burners, and circulating air passageways of the room heater be kept clean. S'assurer que le brûleur et le compartiment des commandes sont propres. Voir les instructions d'installation et d'utilisation qui accompagnent l'appareil.
5. Adequate clearances around the combustion chamber and accessibility clearances for servicing and proper operation must be maintained.
6. Turn off the gas before servicing this appliance. It is recommended that a qualified service technician perform an appliance check-up at the beginning of each heating season.
7. All installations must conform with all local, state, and national codes. In the absence of local codes, the installation must conform with National Fuel Gas Code ANSI Z223.1-latest edition, also known as NFPA 54 (In Canada, the current CAN/CSA B149.1 installation code).

Refer to the National Fuel Gas Code and local zoning and code authorities for details on installation requirements. Your fireplace insert must be vented to the outside in accordance with the latest edition of the National Fuel Gas Code.

8. This gas insert **MUST** be vented directly to the outside and **MUST NEVER** be attached to a chimney serving a separate solid fuel burning appliance. Each gas appliance **MUST USE** a separate vent system. Common vent systems are **PROHIBITED**.
9. Manufactured (mobile) home installations must conform with the Manufactured Home Construction and Safety Standard, Title 24 CFR, Part 3280 (in Canada CAN/CSA Z240 MH) (in Canada CAN/CSA Z240 MH), or, when such a standard is not applicable, the Standard for Manufactured Home Installations, ANSI A225.1.
10. The appliance, when installed, must be electrically grounded in accordance with local codes or in the absence of local codes, with the National Electrical Code, ANSI/NFPA 70 - latest edition. In Canada, the current CSA C22-1 Canadian Electrical Code - latest edition.
11. Your Shoreline™ gas insert must be equipped for the proper fuel type and altitude at which it will be operated. Any operation outside the parameters outlined in this manual may result in a hazardous condition and will void the warranty. Please carefully read the sections pertaining to these subjects and/or be sure your appliance is properly equipped.
12. Do not use this insert if any part has been under water. Immediately call a qualified service technician to inspect the appliance and to replace any part of the control system and any gas control which has been under water.
Ne pas se servir de cet appareil s'il a été plongé dans l'eau, complètement ou en partie. Appeler un technicien qualifié pour inspecter l'appareil et remplacer toute partie du système de contrôle et toute commande qui ont été plongés dans l'eau.
13. Due to high temperatures, the fireplace insert should be located out of traffic areas and away from furniture and draperies. The recommended clearance zone from the front of the appliance to combustibles is 36 inches (914 mm).
14. Children and adults should be alerted to the hazards of high surface temperature and should stay away to avoid burns or clothing ignition. Young children should be carefully supervised when they are in the same room as the gas insert. Clothing or any other flammable material should not be placed on or near the appliance.
Surveiller les enfants. Garder les vêtements, les meubles, l'essence ou autres liquides à vapeur inflammables loin de l'appareil.
15. Never use solid fuels such as wood, paper, cardboard, coal, or any flammable liquids, etc., in this appliance.
16. Any grill, panel, or glass removed for service **MUST** be replaced prior to operating the fireplace insert. Do not operate appliance with the glass front removed, cracked or broken. Replacement of the glass should be done by a qualified service technician.
17. **DO NOT USE** abrasive cleaner on the glass door assembly. **DO NOT ATTEMPT** to clean the glass door when it is hot.
18. Gold and nickel plated surfaces must be cleaned with glass cleaner and a clean soft cloth before firing the first time or fingerprints will remain permanently. **NEVER** use brass polish to clean gold or nickel, this will remove the plating!!!
19. When opening the access door (right side surround panel) be very careful because the door is hot during operation.
20. Lennox Hearth Products, its employees, or any of its representatives assume no responsibility for any damages caused by an inoperable, inadequate, or unsafe condition as a result of any improper operation, service or installation procedures, whether direct or indirect.

CONGRATULATIONS ON THE PURCHASE OF YOUR NEW GAS APPLIANCE MANUFACTURED BY LENNOX HEARTH PRODUCTS.

When you purchased your new gas-fired heater, you joined the ranks of thousands of individuals whose answer to their home heating needs reflects their concern for efficiency and our environment. We extend our continued support to help you achieve the maximum benefit and enjoyment available from your new gas-fired heater. It is our goal at Lennox Hearth Products to provide you, our valued customer, with an appliance that will ensure years of trouble-free warmth and pleasure.

Thank you for selecting a Lennox Hearth Products gas-fired heater as the answer to your home heating needs.

Sincerely, All of us at Lennox Hearth Products

TABLE OF CONTENTS

Important Safety and Warning Information	Page 2
Packaging List.....	Page 3
Introduction	Page 3
General Information	Page 4
Codes and Approvals	Page 4
New York City MEA Approval	Page 6
Requirements for the	
Commonwealth of Massachusetts	Page 6
Specifications - Insert Dimensions	Page 7
Clearances to Combustibles.....	Page 8
Installation	Page 9
Fireplace Requirements.....	Page 9
Venting Requirements.....	Page 10-11
Insert Leveling	Page 11
Door Assembly Installation	
or Removal Instructions.....	Page 12
Refractory Brick Panel Installation Instructions	Page 13
Log Set Installation Instructions	Page 14-15
Surround Installation Instructions	Page 16
Gas Line Installation.....	Page 18
Gas Pressure Requirements.....	Page 18
LP and Natural Gas Supplies.....	Page 18
Operating Instructions	Page 18-22
Pre-Lighting Checklist.....	Page 18
Lighting Instructions.....	Page 19
To Turn Gas Off to Appliance.....	Page 19
Shutdown Procedure	Page 19
Flame Appearance and Sooting.....	Page 20
Air Shutter Adjustment	Page 20
Burn-In Period	Page 21
Quiet Operation	Page 21
Blower Operation and Wiring Diagram.....	Page 21
Shoreline™ Main Burner Operation	Page 22
Millivolt Control System and Wiring Diagram	Page 22
Maintenance and Servicing	Page 23-25
Maintenance Checklist	Page 23
Glass Maintenance	Page 23-24
Door Removal.....	Page 24
Blower Removal.....	Page 24
Paint Touch-Up	Page 24
Inspecting Wiring.....	Page 24
Fuel Conversion Kits	Page 24
Maintenance Schedule	Page 25
Troubleshooting	Page 26
Replacement Parts List	Page 27
Part Identification.....	Page 28-32
Optional Accessories.....	Page 33-35
Safety / Listing Label.....	Page 36
Lighting Instructions Label	Page 37
Warranty and Product Reference Information.....	Page 38

This installation manual will help you obtain a safe, efficient, dependable installation for your appliance and vent system.

PLEASE READ AND UNDERSTAND THESE INSTRUCTIONS BEFORE BEGINNING YOUR INSTALLATION

PACKAGING LIST

To install a Shoreline insert, an insert body, refractory brick panel set and surround kit are required (each sold separately. See **Page 34** for ordering information).

Fireplace Insert Body Packaging List

Model: Shoreline 33/40 DV INS

- | | |
|--------------------------------------|-----------------------------------|
| 1) Fireplace Insert Body | 1) 150 cfm Blower |
| with Burner Cassette | 1) 5-Piece Log Set |
| 1) Gas pipe (3/8" x 8") | 1) Optional Shoreline #33 orifice |
| 1) Installation and Operation Manual | 1) Bag of Decorative Lava Rock |
| 1) Bag of Glowing Ember Material | 1) Fireplace Warning Label |
| 1) Front Leveling Leg Kit | |

Refractory Brick Panel Sets - 6 pieces:

Standard
Red
Architectural Stone

Surround Kits:

Small 3-sided - 36-5/8" Wide x 25-7/8" High (930 mm x 657 mm)
Large 3-sided - 41" Wide x 28" High (1041 mm x 711 mm)
Small 4-sided - 36-5/8" Wide x 29-3/16" High (930 mm x 741 mm)
Large 4-sided - 41" Wide x 33-1/2" High (1041 mm x 851 mm)

INTRODUCTION

The Insert models covered in this manual are direct-vent sealed combustion gas heaters designed for residential application for installation into an existing masonry or factory built solid fuel burning fireplace. The required liners for the air intake and exhaust are as follows:

- **Air Intake: Use 3" diameter UL 181 or UL 1777 listed liner only.**
- **Exhaust: Use 3" diameter UL 1777 listed gas vent liner only. DO NOT USE UL 181 LISTED LINER.**

These vent systems must be routed through the existing fireplace flue system to the vent termination.

Installation Options

- Residential
- Bedrooms
- Manufactured (mobile) home
- Commercial

Your direct vent Insert is designed to be vented vertically with a minimum height of 10 feet and maximum of 35 feet from top of the flue collar using natural gas or propane gas (LP).

This appliance is only for use with the type of gas indicated on the rating plate. This appliance is not convertible for use with other gases, unless a certified kit is used.

Cet appareil doit être utilisé uniquement avec les types de gaz indiqués sur la plaque signalétique. Ne pas l'utiliser avec d'autres gaz sauf si un kit de conversion certifié est installé.

These appliances comply with National Safety Standards and are tested and listed by OMNI-Test Laboratories Inc.; Beaverton, Oregon (Report No. 050-F-22-5) to ANSI Z21.88-2005/CSA 2.33-2005, and CGA 2.17-M91 in both USA and Canada, as Vented Gas Fireplace Heaters and are approved for installation in bedrooms and manufactured (mobile) homes.

GENERAL INFORMATION

Table 1 shows the BTU input for each model:

Millivolt Models with Manually-Modulated Gas Valves		
	Natural Gas	Propane (LP) Gas
Model	Input Rate (BTU/HR)	Input Rate (BTU/HR)
SHR33	19,500 to 33,000	19,500 to 33,000
SHR40	24,000-40,000	21,500 to 37,500

Table 1

Table 2 shows efficiencies for the Shoreline™.

Efficiencies %						
Models	Natural Gas			Propane		
	P4**	Steady State*	AFUE	P4**	Steady State*	AFUE
SHR33	60.91	83	60	64.35	83	65
SHR40	62.70	83	63	65.98	83	67

* The Steady State Efficiency numbers based on maximum vent configuration.
 ** Tested to CSA P.4.1-02 "Testing Method for Measuring Annual Fireplace Efficiency."

Table 2

These appliances may be installed in an aftermarket permanently located, manufactured home (USA only) or mobile home, where not prohibited by local codes.

Cet appareil peut être installé dans un maison préfabriquée (É.-U. seulement) ou mobile déjà installée à demeure si les règlements locaux le permettent.

Note: These appliances are designed as supplemental heaters. Therefore, it is advisable to have an alternate heat source when installed in a dwelling.

Millivolt Valve & Electrical

These appliances use a millivolt type control system consisting of a gas control valve with regulator (control to adjust for flame appearance and heat output), a standing pilot burner assembly, a thermopile, thermocouple, a piezo igniter, and ON/OFF switch. **THE GAS BURNER SYSTEM ON THESE APPLIANCES DO NOT REQUIRE 120 VOLT POWER TO OPERATE.** Because this fireplace insert is operated with a millivolt valve it will burn even during a power outage.

The Shoreline features a spark igniter (piezo) that allows the appliance's pilot gas to be lit without the use of matches or batteries. However, the heat circulation blower motor requires 120 Volts AC (the appliance can be safely used with the blower turned off). The blower operation is controlled by a variable speed rheostat.

Fuel

This insert comes from the factory equipped to burn natural gas from 0 to 2,000 feet (610 M) of elevation in the USA and 0 - 4,500 feet (1372 M) in Canada. The insert can be converted to burn LP (liquid propane) by installing a conversion kit. Only Lennox Hearth Products conversion kits can be used to convert from NG to LP or LP to NG. Contact your Lennox Hearth Products dealer for details. An orifice is also supplied to change the unit from 40,000 BTU's (NG) or 37,500 BTU's (LP) to 33,000 BTU's. This must be done by a qualified service technician if you decide to change orifices.

The use of other fuels or combination of fuels will degrade the performance of this system and may be dangerous.

Orifice Size/Altitude Adjustment

These appliances are tested and approved for installations at elevations of 0 to 2,000 feet (610 M) in the USA and 0 to 4,500 feet (0-1372 M) in Canada using the factory installed orifice shown in Table 3. At higher elevations the BTU input must be de-rated by 4% for every 1,000 feet (305 M) to maintain the proper ratio of gas to air. Contact your local gas supplier for deration requirements for your area.

Deration - At higher elevations, the amount of BTU fuel value delivered must be reduced by either using gas that has been derated by the gas company or by changing the burner orifice to a smaller size as regulated by the local authorities having jurisdiction and by the (USA) National Fuel Gas Code NFPA 54 / ANSI Z223.1 - latest edition or, in Canada, the CAN/CSA B149.1 - latest edition. If it is determined that a smaller burner orifice is needed, contact your Lennox Hearth Products dealer to purchase the orifice.

Burner Orifice Sizes USA - Elevation 0-2000 feet (0-610 meters) Canada - Elevation 0-4500 feet (0-1372 meters)		
Model	Natural Gas drill size (inches) *	Propane drill size (inches) *
SHR33	#36 (0.1065")	#51 (0.067")
SHR40	1/8" (0.125")	#49 (.073")

Table 3 * Standard size installed at factory

CODES AND APPROVALS

Listing and Safety Standards - Gas appliances must be tested and certified by a nationally recognized testing and certification laboratory to ANSI (American National Standard Institute) gas appliance safety standards. This insert has been tested and certified by OMNI -Test Laboratories to ANSI Z21.88-2005/CSA 2.33-2005 "Vented Gas Fireplace Heaters and CGA 2.17-M91 "Gas-Fired Appliances for Use at High Altitudes" and UL 307B Gas Burning Heating Appliances for Manufactured (Mobile) Homes in both USA and Canada. These appliances have been certified for use with either natural gas or propane and are approved for installation in sitting rooms and/or bedrooms. **This appliance is only for use with the type of gas indicated on the rating plate (and is not for use with solid fuels). This appliance is not convertible for use with other gases, unless a certified kit is used.**

Cet appareil doit être utilisé uniquement avec les types de gaz indiqués sur la plaque signalétique. Ne pas l'utiliser avec d'autres gaz sauf si un kit de conversion certifié est installé.

Manufactured Home Installations - These appliances must conform to the Manufactured Home Construction and Safety Standard, Title 24 CFR, Part 3280 (in Canada CAN/CSA Z240 MH) (in Canada CAN/CSA Z240 MH), or when such a standard is not applicable, the Standard for Manufactured Home Installations, ANSI A225.1 - latest edition for manufactured (mobile) home installations and the current Standard for Fire Safety Criteria for Manufactured Home Installations, Sites and Communities, ANSI/NFPA 501A.

Local, State and National Codes - These appliances must conform with all local, state, and national installation codes. In the absence of local and state codes, installation must comply with the current National Fuel Gas Code, ANSI Z223.1, also known as NFPA 54 (In Canada, the current CAN/CSA B149.1 installation code). Electrical wiring must comply with the National Electrical Code ANSI/NFPA 70 - latest edition. In Canada, the current CSA C22-1 Canadian Electrical Code - latest edition. Refer to the National Fuel Gas Code and local zoning and code authorities for details on installation requirements. These appliances must be vented directly to the outside in accordance with the current edition of the National Fuel Gas Code (NFPA 54 in U.S.A and CAN/CSA B149.1 in Canada) and must never be attached to a chimney serving a separate solid fuel burning appliance.

Fireplace Standards - These heaters are designed to be installed into an existing masonry fireplace (built to UBC 37 or ULC S628 standards) or factory built solid fuel, wood, burning fireplace (listed to UL 127 or ULC S610) only. All exhaust gases must be vented outside the structure. Combustion air is drawn from outside the structure.

Questions To Ask Local Building Official

These appliances must be installed per manufacturers' instructions. Installations must conform to appropriate local codes and applicable state and federal requirements. Familiarity with these requirements before installation is essential. Some important considerations to discuss with local building officials include:

1. Applicable codes (i.e. Uniform Mechanical Code, State or Regional Gas Codes, National Fuel Gas Code).
2. Local amendments
3. Recognized testing lab: OMNI-Test Laboratories Inc.; Beaverton, Oregon
4. Is a permit required - cost?
5. In some states or municipalities, a licensed gas fitter or plumber may be required to install these appliances. Check with your local building official for requirements in your area (i.e. Is a license required for installation of gas supply line)?
6. Maximum amount of gas pipe without a pressure test - type of test required?
7. Are below grade penetrations of the gas line allowed?
8. Is concealed gas piping allowed?
9. Specific requirements of concealed fittings?
10. Is rigid pipe to appliance required?
11. Allowed piping materials?
12. Shut-off valve required within 4 feet of the firebox?
13. May the shut-off valve be concealed?
14. Rooms where the installation is not allowed?

NEW YORK CITY, NEW YORK (MEA)

Installation of these fireplaces are approved for installation in New York City in the US state of New York (MEA#: 138-07-E).

COMMONWEALTH OF MASSACHUSETTS REQUIREMENTS

Note: The following requirements reference various Massachusetts and national codes not contained in this document.

For all side wall horizontally vented gas fueled equipment installed in every dwelling, building or structure used in whole or in part for residential purposes, including those owned or operated by the Commonwealth and where the side wall exhaust vent termination is less than seven (7) feet above finished grade in the area of the venting, including but not limited to decks and porches, the following requirements shall be satisfied:

Installation Of Carbon Monoxide Detectors

At the time of installation of the side wall horizontal vented gas fueled equipment, the installing plumber or gas-fitter shall observe that a hard wired carbon monoxide detector with an alarm and battery back-up is installed on the floor level where the gas equipment is to be installed. In addition, the installing plumber or gas-fitter shall observe that a battery operated or hard wired carbon monoxide detector with an alarm is installed on each additional level of the dwelling, building or structure served by the side wall horizontal vented gas fueled equipment. It shall be the responsibility of the property owner to secure the services of qualified licensed professionals for the installation of hard wired carbon monoxide detectors.

In the event that the side wall horizontally vented gas fueled equipment is installed in a crawl space or an attic, the hard wired carbon monoxide detector with alarm and battery back-up may be installed on the next adjacent floor level.

In the event that the requirements of this subdivision can not be met at the time of completion of installation, the owner shall have a period of thirty (30) days to comply with the above requirements; provided, however, that during said thirty (30) day period, a battery operated carbon monoxide detector with an alarm shall be installed.

Approved Carbon Monoxide Detectors

Each carbon monoxide detector as required in accordance with the above provisions shall comply with NFPA 720 and be ANSI/UL 2034 listed and IAS certified.

Signage

A metal or plastic identification plate shall be permanently mounted to the exterior of the building at a minimum height of eight (8) feet above grade directly in line with the exhaust vent terminal for the horizontally vented gas fueled heating appliance or equipment. The sign shall read, in print size no less than one-half (1/2) inch in size, **"GAS VENT DIRECTLY BELOW. KEEP CLEAR OF ALL OBSTRUCTIONS."**

Inspection

The state or local gas inspector of the side wall horizontally vented gas fueled equipment shall not approve the installation unless, upon inspection, the inspector observes carbon monoxide detectors and signage installed in accordance with the provisions of 248 CMR 5.08(2)(a)1 through 4.

Exemptions

The following equipment is exempt from 248 CMR 5.08(2)(a)1 through 4:

- The equipment listed in Chapter 10 entitled "Equipment Not Required To Be Vented" in the most current edition of ANSI Z233.1 / NFPA 54 (In Canada CAN/CSA B149.1 - current edition) as adopted by the Board; and
- Product Approved side wall horizontally vented gas fueled equipment installed in a room or structure separate from the dwelling, building or structure used in whole or in part for residential purposes.

MANUFACTURER REQUIREMENTS

Gas Equipment Venting System Provided

When the manufacturer of Product Approved side wall horizontally vented gas equipment provides a venting system design or venting system components with the equipment, the instructions provided by the manufacturer for installation of the equipment and the venting system shall include:

- Detailed instructions for the installation of the venting system design or the venting system components; and
- A complete parts list for the venting system design or venting system.

Gas Equipment Venting System NOT Provided

When the manufacturer of a Product Approved side wall horizontally vented gas fueled equipment does not provide the parts for venting the flue gases, but identifies "special venting systems", the following requirements shall be satisfied by the manufacturer:

- The referenced "special venting system" instructions shall be included with the appliance or equipment installation instructions; and
- The "special venting systems" shall be Product Approved by the Board, and the instructions for that system shall include a parts list and detailed installation instructions.

A copy of all installation instructions for all Product Approved side wall horizontally vented gas fueled equipment, all venting instructions, all parts lists for venting instructions, and/or all venting design instructions shall remain with the appliance or equipment at the completion of the installation.

- Installation and repair must be done by a plumber or gas fitter licensed in the Commonwealth of Massachusetts.
- The flexible gas line connector used shall not exceed 36 inches (92 centimeters) in length.
- The individual manual shut-off must be a T-handle type valve.

SPECIFICATIONS: Shoreline™

Insert Dimensions		Inches (millimeters)
A	Left front of unit to center line	13-1/8 (333)
B	Right front of unit to center line	17-1/4 (438)
C	Left rear of unit to center line	9 (229)
D	Right Rear Of Unit To Center Line	7-5/8 (194)
E	Center Of Air Intake To Center Line	6-3/4 (172)
F	Center Of Flue To Center Line	2 (51)
G	Insert Depth Into Fireplace	15-3/8 (391)
H	Air Intake Center From Front	12-7/8 (327)
I	Flue Center From Front Of Unit	14 (356)
J	Front Of Unit To Back Of Flue Collar	15-1/8 (384)
K	Unit Height At Front	22-3/8 (568)
L	Base Of Unit To Top Of Flue Collar	21 (533)
M	Base Of Unit To Intake Collar	7-7/8 (200)
N	O.D. Width, Small, 3-pc Flange	36-5/8 (930)
N	O.D. Width, Large, 3-pc Flange	41 (1041)
O	O.D. Height, Small, 3-pc Flange	25-7/8 (657)
O	O.D. Height, Large, 3-pc Flange	28 (711)
P	O.D. Width, Small, 4-pc Flange	36-5/8 (930)
P	O.D. Width, Large, 4-pc Flange	41 (1041)
Q	O.D. Height, Small, 4-pc Flange	29-3/16 (741)
Q	O.D. Height, Large, 4-pc Flange	33-1/2 (851)
R	Glass Viewing Height	16-7/8 (429)
S	Glass Viewing Width	26-5/8 (676)

Rear Insert Dimensions - Inches (millimeters)	
Rear width of unit	16-5/8 (422)
Front Width of unit	30-3/8 (772)
Depth of unit (excluding Surround Kit)	15-3/8 (391)

Note: Due to Lennox' ongoing commitment to quality, all specifications, ratings and dimensions are subject to change without notice.

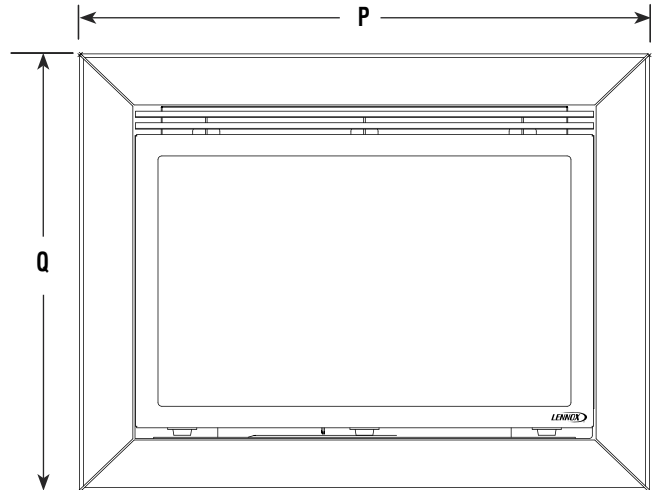

Front View 4-Sided Surround Kit

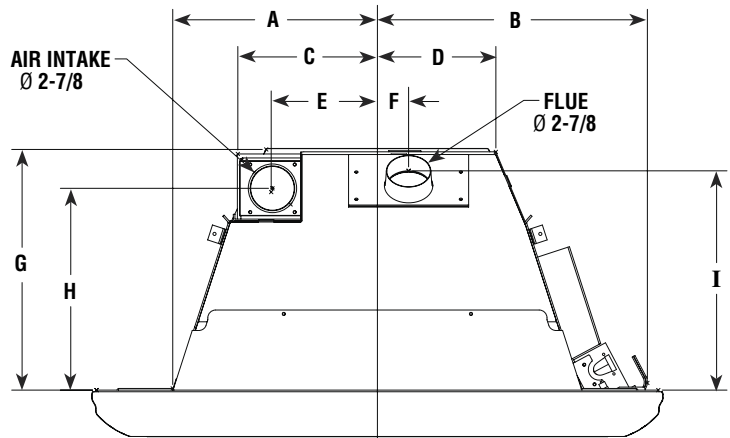

Top View Center

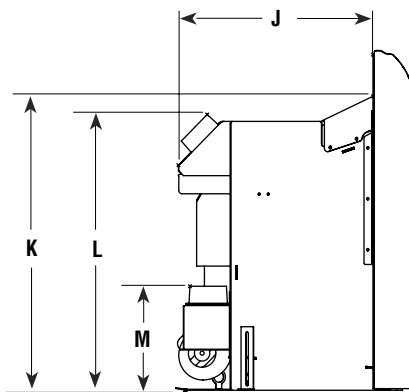

Side View

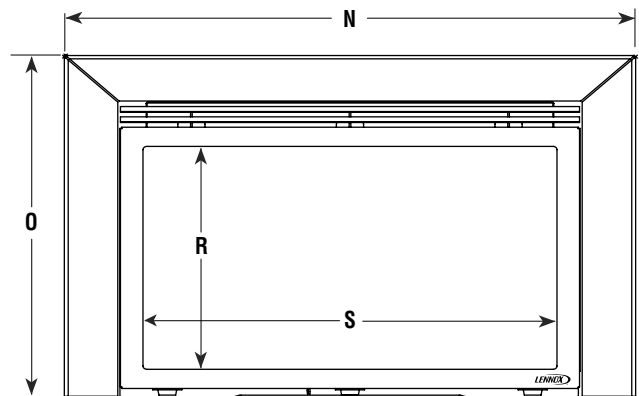

Front View 3-Sided Surround Kit

Figure 1

NOTE: DIAGRAMS AND ILLUSTRATIONS ARE NOT TO SCALE

MINIMUM CLEARANCES TO COMBUSTIBLES

These appliances can be installed in most fireplace configurations. If installed close to an adjacent wall, ensure that the minimum clearances to combustible surfaces are maintained. A local building inspector should review your plans prior to installation.

Refer to **Figures 2 through 4** for clearances to combustibles. Minimum clearances include any projections such as shelves, window sills, mantels, spacers/standoffs or surfaces to combustible construction etc. above the appliance. Paint or lacquer used to finish the mantel must be heat resistant in order to avoid discoloration.

	Minimum Fireplace Dimensions and Minimum Clearances	Inches (millimeters)
A	Minimum front opening required	36 (914)
B	Minimum height required	21-1/2 (546)
C	Minimum rear width required	19-1/2 (495)
D	Minimum fireplace depth required	16 (406)
E	Clearance needed from bottom of insert to combustibles or 8" mantel	35 (889)
F	Clearance required from center of glass to combustible material	30 (762)
G	Minimum inches of hearth protection needed from front of unit	12 (305)
H	Vertical clearance needed under the bottom of the insert for NO hearth protection	8 (203)
I	Clearance needed from bottom of insert to 12" mantel	38 (965)

Table 4 Refer to Figures 2 through 4

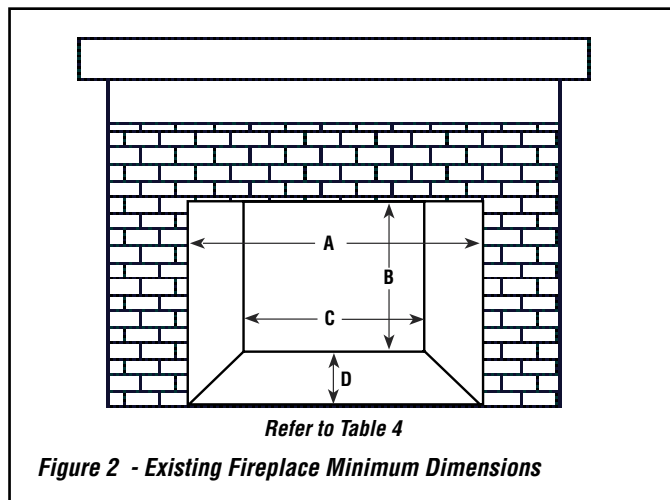

Hearth / Floor Protection Requirements

The hearth and/or floor protection must be a thermally rated hearth/floor protector meeting or exceeding a thermal rating of $k = .84$ (or lower) or $r = 1.19$ (or higher) with a listed thickness of 1" minimum. If an hearth extension is used, check with the manufacturer for the listed thermal rating of the hearth extension to ensure it meets the thermal requirements of $k = .84$, $r = 1.19$, listed thickness 1". If a custom hearth or floor protection is planned, see NFI (National Fireplace Institute) certification manuals showing methods for calculating minimum thicknesses and approved fireplace hearth/floor protection materials.

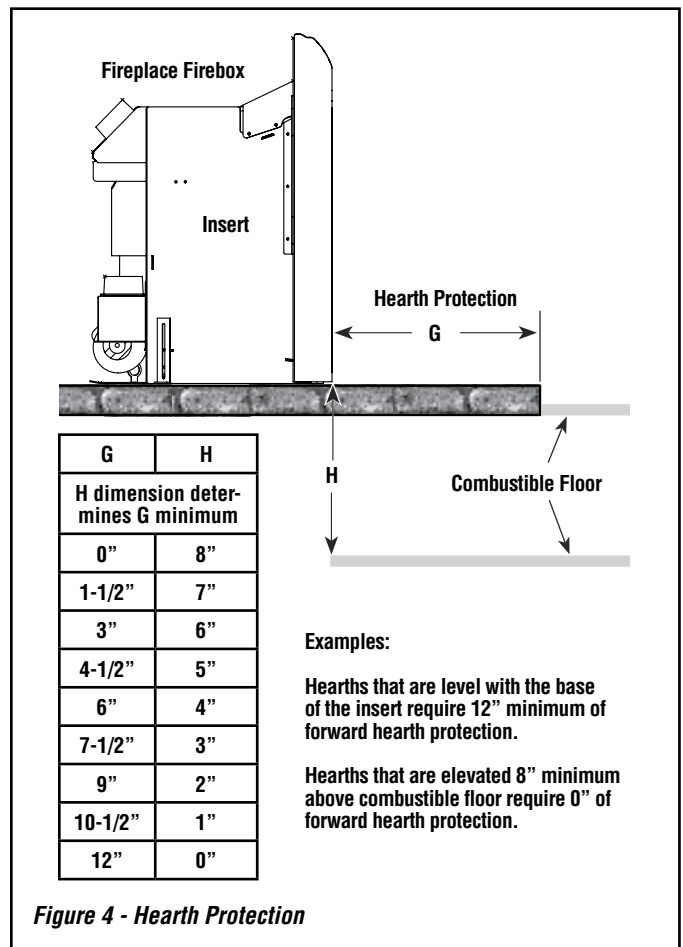
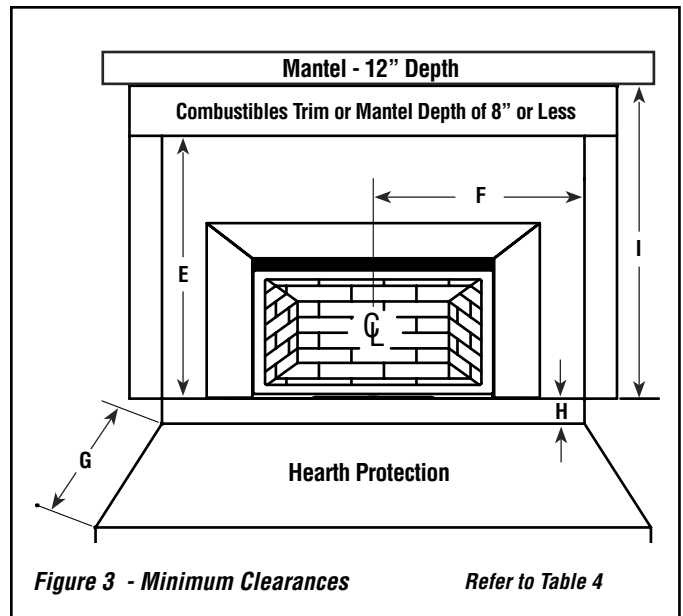

Examples:

Hearths that are level with the base of the insert require 12" minimum of forward hearth protection.

Hearths that are elevated 8" minimum above combustible floor require 0" of forward hearth protection.

INSTALLATION

Fireplace Requirements

These heaters are designed to be installed into an existing masonry fireplace (built to UBC 37 or ULC S628 standards) or factory built solid fuel, wood burning fireplace (listed to UL 127 or ULC S610) only. All exhaust gases must be vented outside the structure. Combustion air is drawn from outside the structure. When installing in a factory built fireplace, the fireplace grate must be removed and the damper must be removed or secured open.

The insert is designed to fit into a fireplace with a minimum firebox height of 21-1/2 inches (546 mm). To facilitate this the hood will need to be removed and discarded (*Note: the screws should be replaced in the insert body*). The air intake on the Shoreline™ is removable for easier installation.

If the factory-built fireplace has no gas access hole(s) provided, an access hole of 1-1/2 inches (38 mm) or less may be drilled through the lower sides or bottom of the firebox in a proper workmanship like manner. This access hole must be plugged with a non-combustible insulation after the gas supply line has been installed. The installer must mechanically attach the marking supplied with the gas fireplace insert to the inside of the firebox of the fireplace into which the gas fireplace insert is installed.

IMPORTANT: When installing these appliances into a factory built fireplace or heat-form, the air flow within and around the fireplace shall not be altered by the installation of the insert (i.e. DO NOT BLOCK louvers or cooling air inlet or outlet ports, circulating air chambers in a steel fireplace liner or metal heat circulator).

WARNING

THIS FIREPLACE HAS BEEN ALTERED TO ACCOMMODATE A FIREPLACE INSERT AND SHOULD BE INSPECTED BY A QUALIFIED PERSON PRIOR TO RE-USE AS A CONVENTIONAL FIREPLACE.

Figure 5 - Fireplace Warning Label

⚠ CAUTIONS

- The fireplace in which this gas insert is to be installed must be thoroughly cleaned if it has been used to burn wood or synthetic logs. Have the chimney and all inside surfaces of the fireplace brushed and vacuumed so that no soot, embers, or loose combustion deposits can be drawn into the heat circulation blower and blown into the living area.
- If any portion of the chimney system shows signs of structural or mechanical weaknesses, such as: cracks, leaky joints, corroded or warped surfaces, the faulty portion must be repaired or replaced prior to installing this appliance.
- The factory built firebox must accept the insert without modification other than removing bolted or screwed together pieces such as baffles / smoke shelf / deflectors, ash lips, glass door, screen or door tracks, log grates, refractory or masonry lining and damper assemblies. Any fireplace component, which is removed, must be retained so they can be reinstalled to restore the fireplace to its original operating condition. The removal of any part must not alter the integrity of the outer shell of the pre-engineered fireplace cabinet in any way. Any parts removed must be replaceable. If any components are removed from (or altered) from the existing fireplace, a Warning Label (see *Figure 5*) must be affixed inside the fireplace firebox, so that it shall be visible upon removal of the fireplace insert. Note: RTV high temperature silicone is an approved adhesive to affix the label.

Venting Requirements

Approved Vent Systems:

Lennox Hearth Products Co-linear Chimney Liner Kit Recommended:

- The Flex Kit, Cat. No. H0909 includes one 35 feet flex liner and four gear clamps.
- The Termination Kit, Cat. No. TKDVI includes the termination cap with two co-linear collars for 3 inches (76 mm) flex attachments and flashing.

Secure Vent™ Co-Linear Chimney Liner Kit Recommended:

- Direct Vent Vertical Termination Kit (includes Vertical Termination Cap gas/Connector, Flashing, Qty 2 of 25 feet (7.6 M) length of 3 inches (76 mm) Aluminum Flex, Clamps and Sealant) #DV3FK25
- Direct Vent Vertical Termination Kit (includes Vertical Termination Cap/Connector, Flashing, Qty 2 of 35 feet length of 3 inches Aluminum Flex, Clamps and Sealant) #DV3FK35

Standard Simpson Dura-vent Co-linear Chimney Liner Kit recommended:

- Direct Vent Vertical Termination Cap #991
- Liner Termination Kit (includes termination connector and flashing) #923GK
- 3" x 35 feet (76 mm x .91 M) Alum Flex #2280

Selkirk/Metalbestos Direct-Temp Co-Linear Chimney Liner Kit recommended

- Direct Vent Vertical Termination Cap #4DT-VC
- Liner Termination Kit (includes termination connector and flashing) #4DT-CTB
- 3" x 35' (76 mm x .91 M) Aluminum Flex #AF3-35L

Amerivent Direct Co-Linear Chimney Liner Kit recommended

- Direct Vent Vertical Termination Cap #4DVC
- Co-Linear Adaptor #4DCAT33
- Flashing #4DF or #5DF
- 3" x 35' Aluminum Flex #3AFL-35

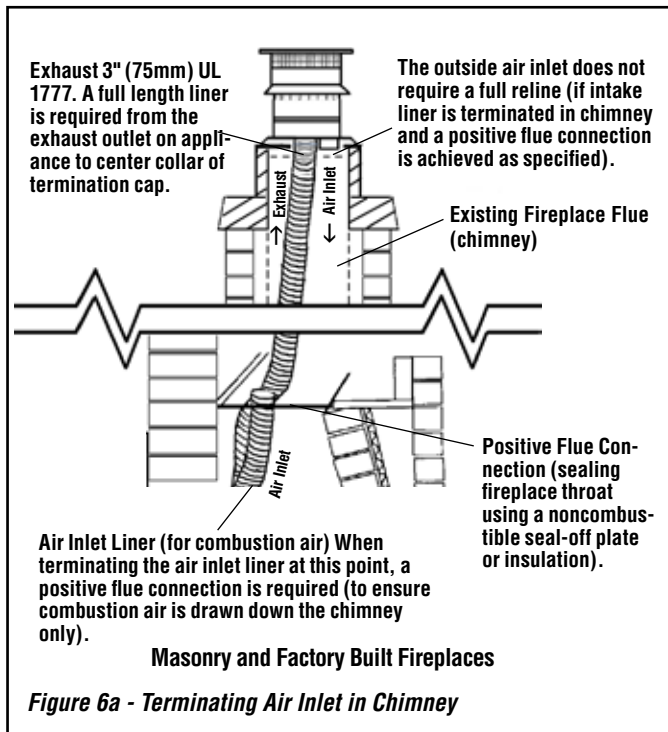

Positive Flue Connection (acceptable methods for sealing chimney throat) Masonry and Factory Built Fireplaces

A qualified installer should evaluate the existing fireplace to determine the best method for achieving a positive flue connection between the vent and intake liners and the chimney. One method is to secure a noncombustible seal-off plate (i.e. 22-gage sheet steel) in the fireplace throat using masonry screws. Other acceptable methods include packing unfaced fiberglass insulation around the liners. Whichever "seal off" method is used must effectively seal the area to prevent room air passage to the chimney of the fireplace.

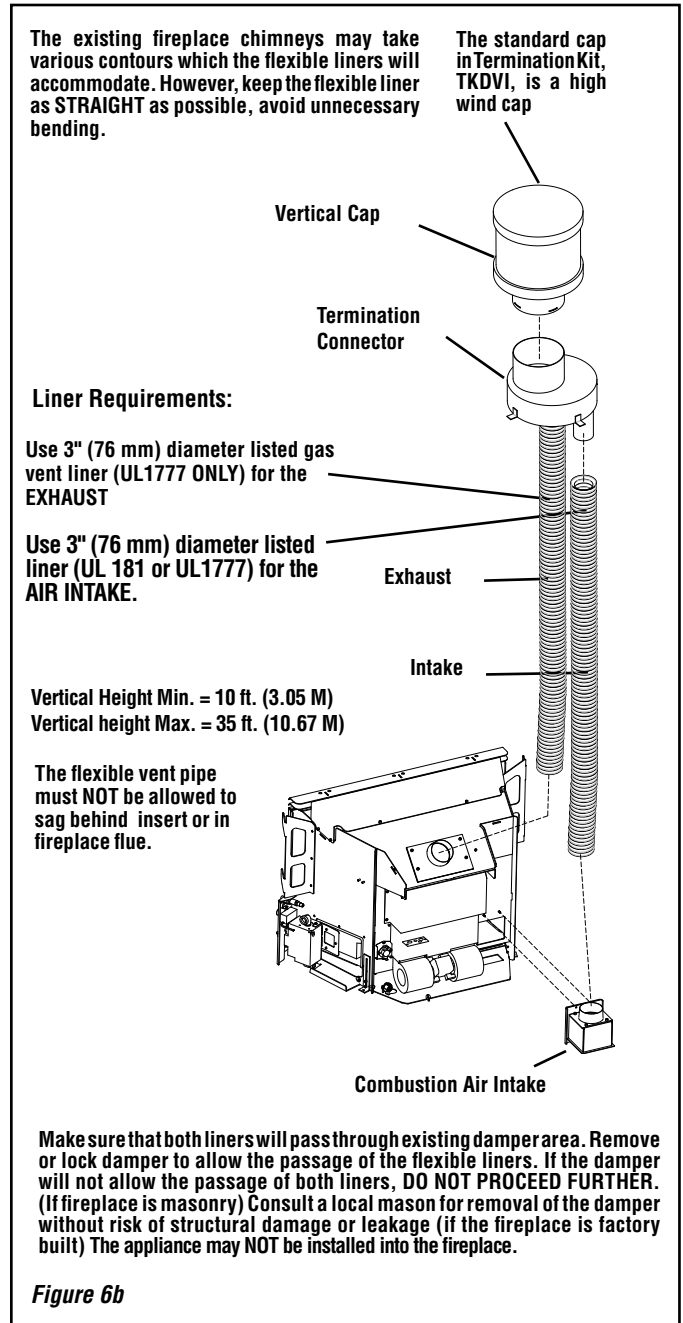

WARNING

Do not substitute the heat-rated flex liner (UL1777) for the exhaust with any other type liner or a fire may result causing property damage, personal injury or loss of life.

Vertical Venting

The vent pipes must be connected to the proper collars on the unit and the exhaust vent pipe must be connected to the termination cap or the unit will not operate. The combustion air vent pipe can be connected to the termination cap (see **Figure 6b**) or it can terminate inside the chimney (see **Figure 6a**). The bottom opening of the chimney must be sealed around the vent pipes if the combustion air vent is not connected to the termination cap. Use unfaced fiberglass insulation to seal around the vent pipes or a positive flue connection using a seal-off plate. The insulation may give off an odor during the first hour of operation.

NOTES:

The minimum vertical rise (exhaust vent) is 10 feet (3.05 M) and the maximum vertical rise is 35 feet (10.67 M). These dimensions are measured from the flue collar of the unit to the end of the vent pipe. The fireplace and fireplace chimney must be clean and in good working order and constructed of non-combustible materials. Inspect chimney clean-outs for proper fit and seal.

See **Table 5** for the minimum vertical termination height requirements.

Vertical Termination Height Minimum (Factory Built and Masonry Fireplaces)

The vent/air intake termination clearances above the high side of an angled roof is as follows:

Feet (meters)	2/12	4/12	6/12	8/12	10/12	12/12	14/12	16/12
8 (2.4)								
7 (2.1)								
6 (1.8)								
5 (1.5)								
4 (1.2)								
3 (0.9)								
2 (0.6)								
1 (0.3)								
0 (0.0)								

Table 5

Insert Leveling

At each front and rear corner of the insert is an adjustable leg provided to level the insert should the hearth of the fireplace be uneven. To adjust the legs in the rear, loosen the two 5/32" allen head screws, move the leg to the desired height, and then tighten the screws. Repeat these steps for each adjusting leg. To adjust the legs in the front use a 9/16" open end wrench. See **Figures 7 and 8**.

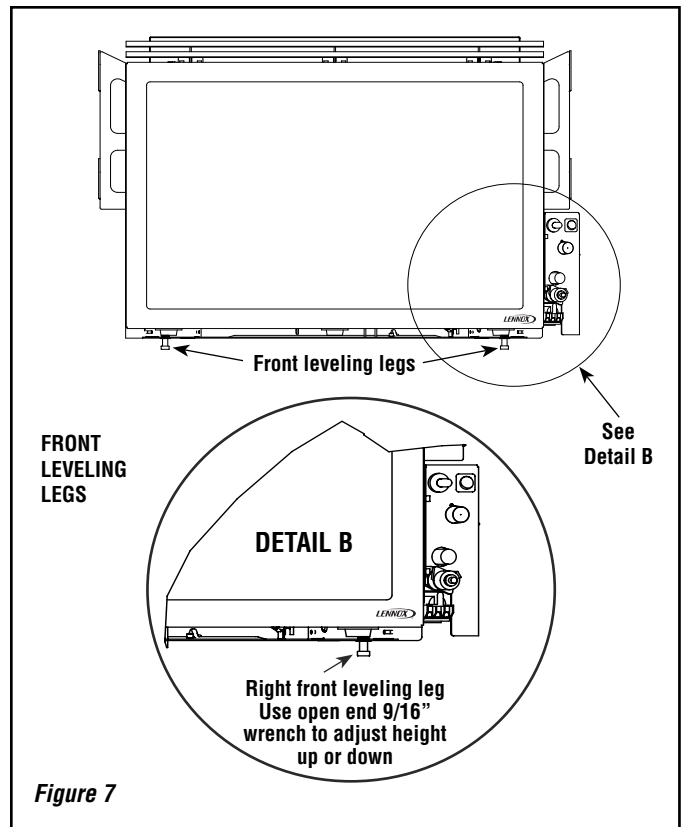

Figure 7

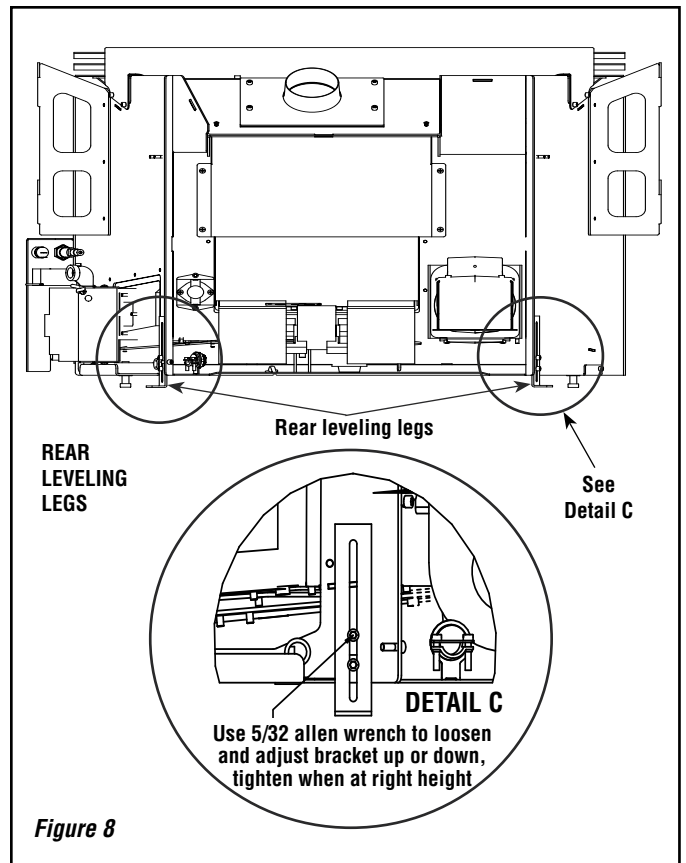

Figure 8

SHORELINE™ DOOR ASSEMBLY INSTALLATION OR REMOVAL INSTRUCTIONS

Tools Needed: No tools are needed

Cat. No. H5746 **Description**
Shoreline Door Assembly (Figure 9)

Shoreline Door Kit - Packaging List	
Models SHR33 & SHR40	
Quantity	Description
1	Shoreline Door Assembly

Table 6 - (refer to Figure 9)

Note: *The Shoreline insert comes with the door already on the unit. Just reverse the steps here to remove the door to access the burner area.*

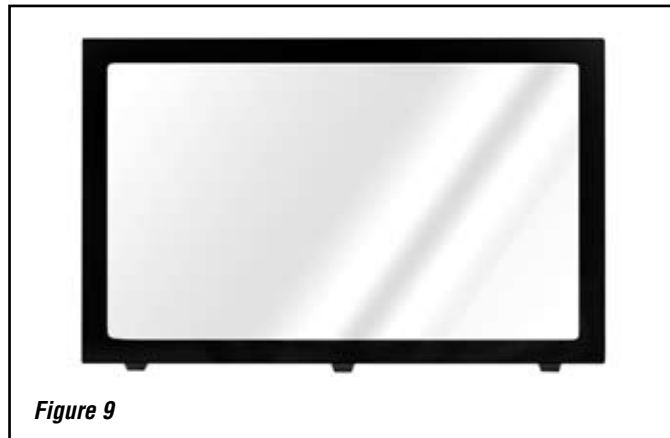

Figure 9

1. Locate three tabs on the bottom of the door. These tabs will go into the tab slots along the bottom of insert. See **Figure 10**.

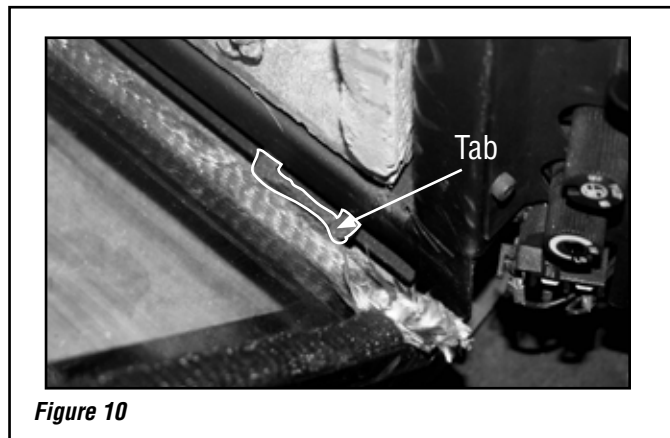

Figure 10

2. Drop the door into the three tab slots on the bottom of the insert as shown in **Figure 11**. The door should be at a 25 degree angle to the front of the insert to be able to place the door correctly.



Figure 11

3. Pull the louvers out to the farthest point and then lift up. Push door against the face of the insert. Drop the louvers down and let the springs pull the three latches into the three slots located on the top of the insert. See **Figure 12**.



Figure 12

4. **Figure 13** shows the insert with the door in place.

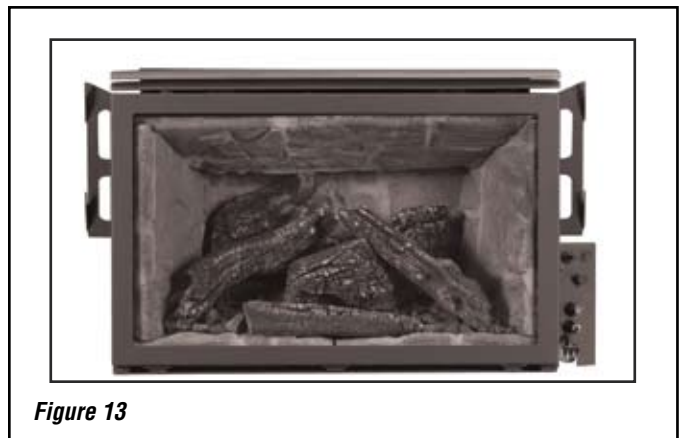

Figure 13

SHORELINE™ REFRACTORY BRICK INSTALLATION INSTRUCTIONS

Tools Needed: No tools are needed

Cat. No.	Model	Description
75383	SHR-BRICK-STD	Brick Panel Set, Standard
75384	SHR-BRICK-RED	Brick Panel Set, Red
75391	SHR-BRICK-ARCHSTONE	Brick Panel Set, Architectural (shown)

Refractory Brick Panel Kits - Packaging List

Models SHR33 & SHR40

Quantity	Description
2	Front Bottom Panels - Left (A), Right (B)
1	Rear Panel (C)
1	Left Side Panel (D)
1	Right Side Panel (E)
1	Top Panel (F)

Table 7 - (refer to Figure 14)

IMPORTANT NOTE: A refractory brick panel kit is required for proper operation (sold separately). Never operate this appliance without all the refractory brick panels properly installed.

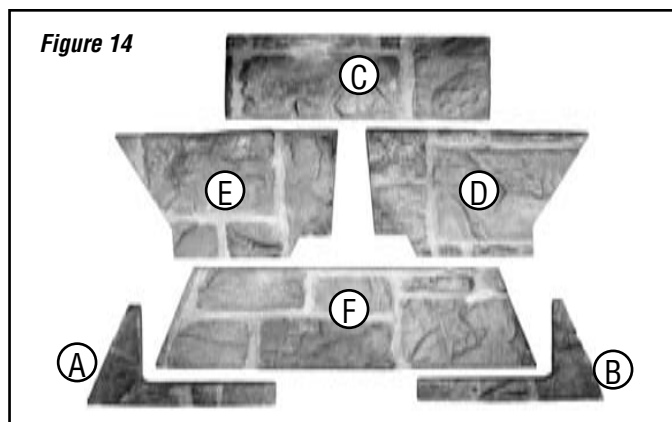

CAUTION

Before you install the refractory brick panels and log set, the insert should be installed in the fireplace, the venting attached, the gas line connected and tested for leaks and the initial burner operation checked.

To Install Panels:

1. Start with the front bottom panels (A and B). Set them in place with detail side up as shown. See *Figure 15*.

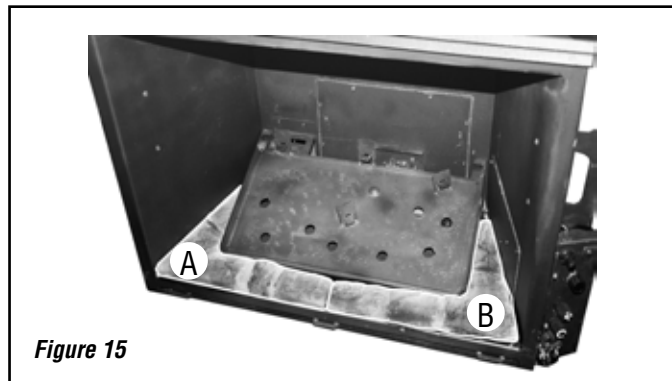

Figure 15

2. Next place the rear panel (C). It will set on the bracket mounted to the blower mounting plate on the back of the firebox. See *Figure 16*.

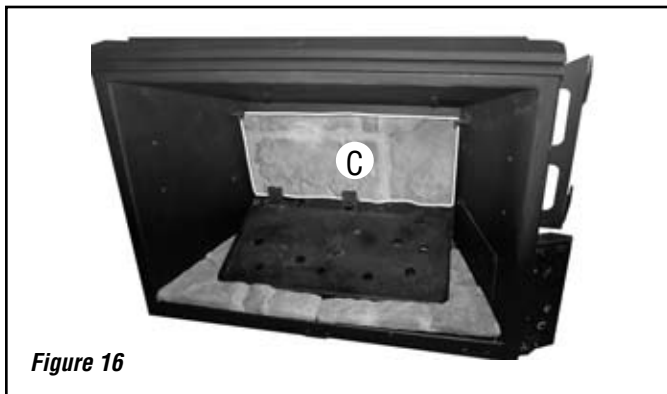

Figure 16

3. Position and slide the side panels against the rear panel. Make sure panels are behind brackets to hold them in at the top. The side panels will hold the rear brick panel against the back of the firebox. See *Figure 17*.

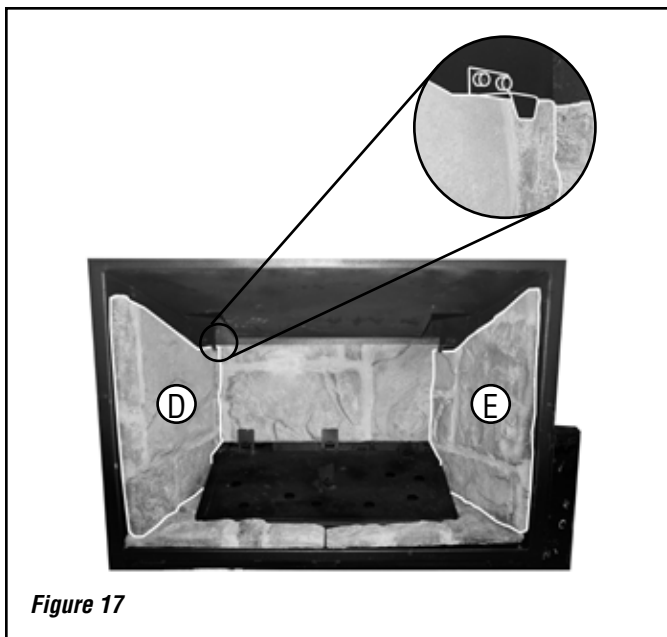

Figure 17

4. Slide the top panel in place with the detailed side down. Make sure panel is positioned all way back and resting on side panels. Top panel should be flush in front with the side panels. See *Figure 18*.

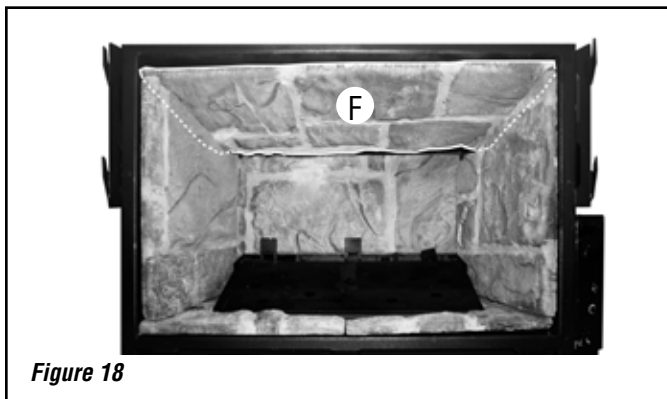

Figure 18

NOTE: DIAGRAMS AND ILLUSTRATIONS ARE NOT TO SCALE

SHORELINE™ LOG SET INSTALLATION INSTRUCTIONS

Tools Needed: No tools are needed

Cat. No. H5747 **Description**
5-Piece Ceramic Log Set

Log Set - Packaging List	
Models SHR33 & SHR40	
Quantity	Description
1	Rear Log (A)
1	Center Log (B)
1	Left Log (C)
1	Right Log (D)
1	Front Log (E)
1	Bag of Glowing Embers (F)
1	Bag of Decorative Lava Rock (G)

Table 8 - (refer to Figure 19)

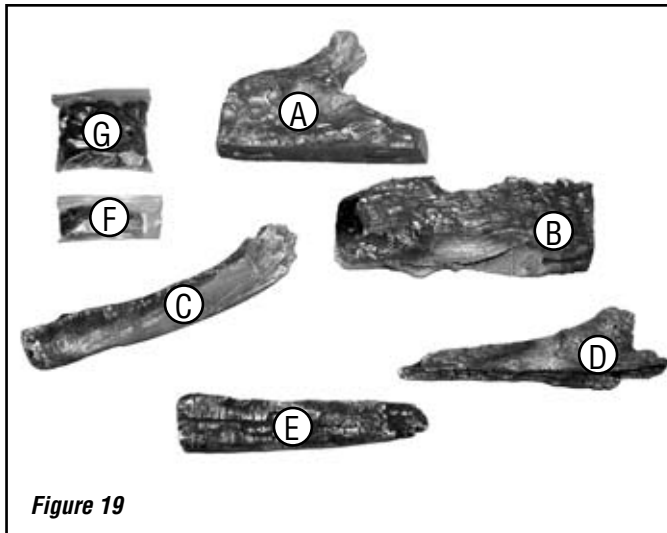

Figure 19

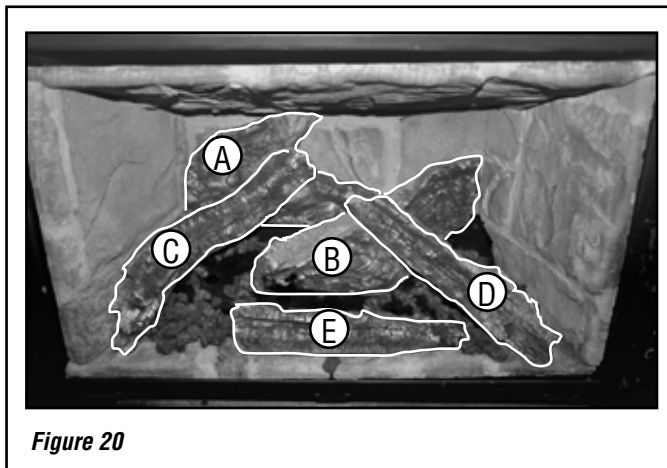

Figure 20

⚠ CAUTIONS

- If logs are not installed according to the log installation instructions, flame impingement and improper combustion could occur and result in soot and/or excessive production of carbon monoxide (CO), a colorless, odorless, toxic gas.
- The size and position of the log set is critical to achieve a safe, reliable and attractive flame pattern. Any attempt to use a different log set in the fireplace will void the warranty and will result in incomplete combustion, sooting, and poor flame quality.

To Install Log Set:

1. Open the box and carefully remove and identify the different items. Start with the rear log (A). Set it down on the log supports located on the left rear of firebox. See *Figure 21*.

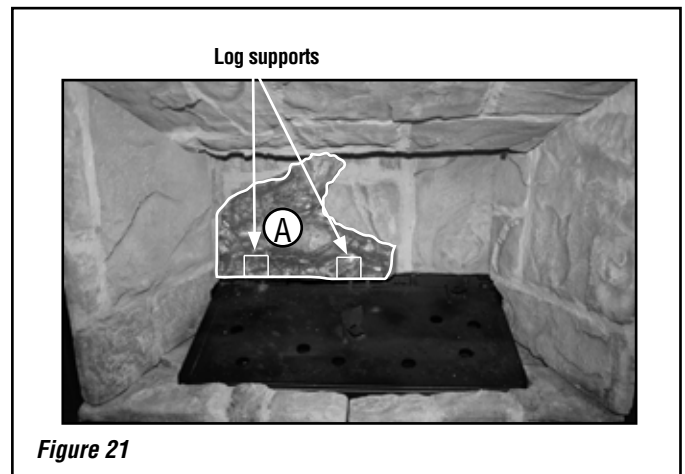
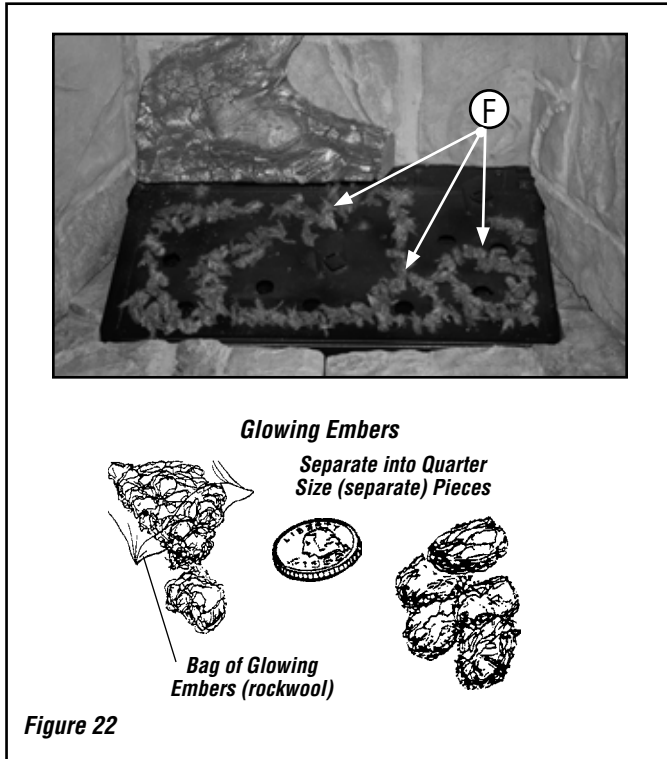
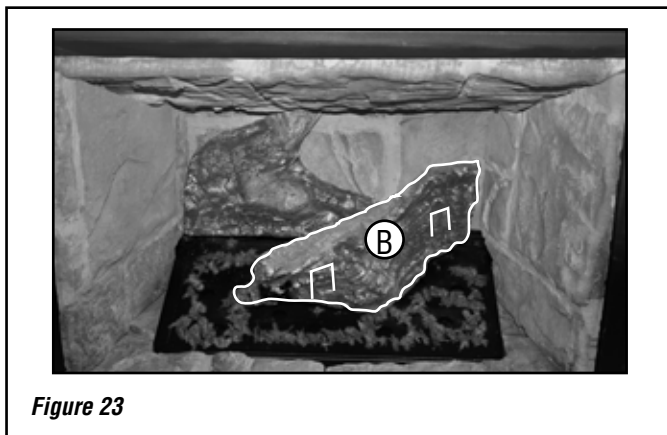

Figure 21

- Separate the glowing embers (F) into quarter size pieces and place along ports on burner pan. DO NOT cover burner secondary holes on burner pan. The pattern for the glowing embers should be similar to what is shown in **Figure 22**.



- Place center log (B) on supports towards bottom left and top right of log (B). See **Figure 23**.



- Place left log (C) on pin in back. Push log against left side of refractory in front. See **Figure 24**.

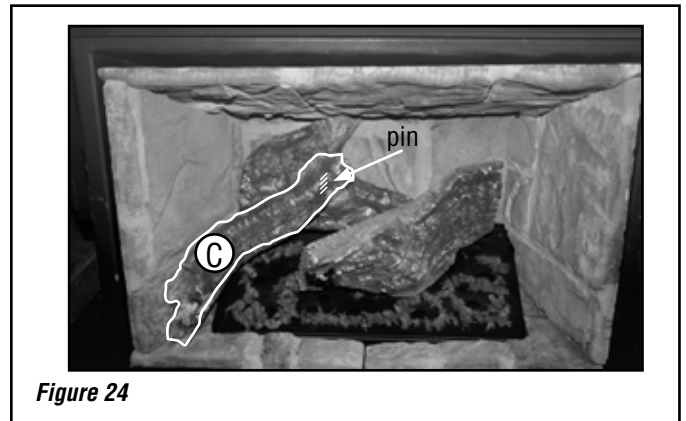

- Locate groove in center log (B), and place the top of the right log (D) in groove with the bottom end of the log resting against the right refractory panel. See **Figure 25**.

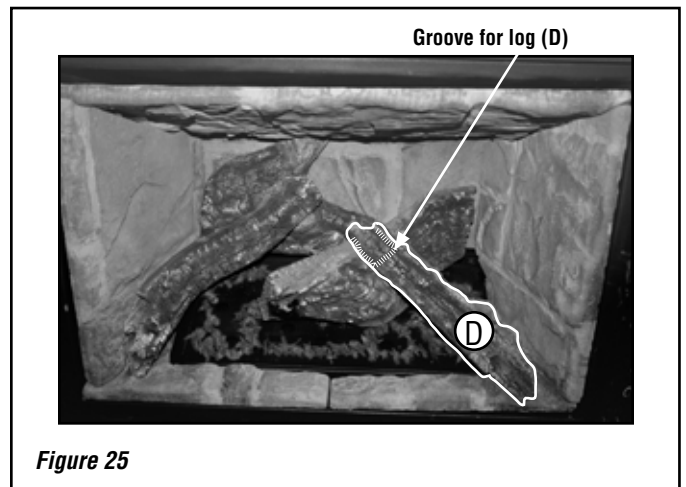

- Place the front log (E) as shown in **Figure 26**, making sure no burner ports are covered. Place the decorative lava rock around logs as desired, again making sure there are no ports or holes covered.

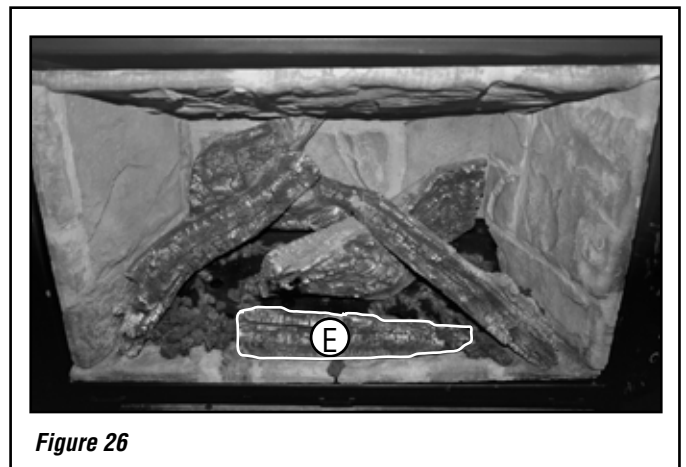

- Figure 26** shows the complete set of ceramic logs in the correct locations.

SHORELINE™ SURROUND ASSEMBLY INSTALLATION

Tools Needed: No tools are needed

One of the following surround kits is required (Purchased separately).

Surround Kits		
Models SHR33 & SHR40		
Part/Cat. #	Description	Dimensions
75387	Small 3-sided Flange	36-5/8"W x 25-7/8"H
75385	Small 4-sided Flange	36-5/8"W x 29-3/16"H
75388	Large 3-sided Flange	41"W x 28"H
75386	Large 4-sided Flange	41"W x 33-1/2"H

Table 9

Note: Install surround with insert positioned in the fireplace, but a few inches in front of its final location.



Figure 27

To Install Surround Panels:

1. Hang the surround on hooks attached to insert (labeled A and B). Make sure the surround is seated firmly on the hooks. See **Figures 28 and 29**.

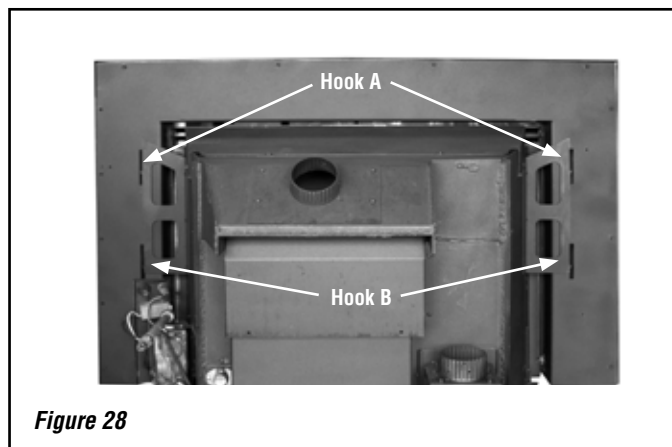

Figure 28

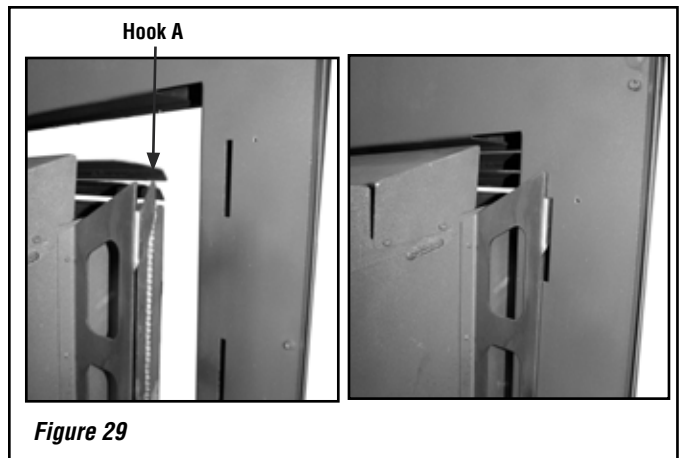

Figure 29

2. Slide the insert into its final location in the fireplace. In case of uneven wall surface open the right surround access door and make any adjustments needed to ensure there is enough clearance to open the access door (see **Page 17**).



Figure 30

Important Note: The trim panels or surrounds must not seal ventilation openings on the appliance.

SURROUND BALL SCREW MOUNT ADJUSTMENT

Tools Needed:

7/16" wrench
Flat End Screwdriver

Adjustment Procedure:

- Step 1** Open the surround access door. Inspect the tension or lack of tension while opening the door to determine if it should open easier or tighter.
- Step 2** With the access door open you will see the ball screw latch as shown in **Picture A and B**. Using a 7/16" wrench, loosen the jam nut on the ball screw assembly as shown in **Picture F**.
- Step 3** Once this jam nut is loose you can then adjust the ball screw for more or less tension using your hand **Picture E** or the flat end of a screwdriver as seen in **Picture D**. Turning the screw counter-clockwise, as you are looking at it, will give you more tension and turning the screw clockwise will give you less tension.
- Step 4** You can then test close the surround access door to ensure it has proper tension. Readjust if needed.
- Step 5** Once proper tension is achieved, hold the ball screw with either your hand or a flat screwdriver, then using a 7/16" wrench tighten the jam, counter-clockwise (**SNUG ONLY, DO NOT OVERTIGHTEN**).

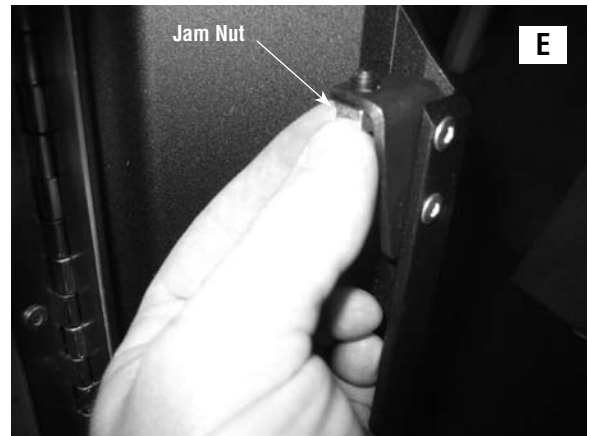
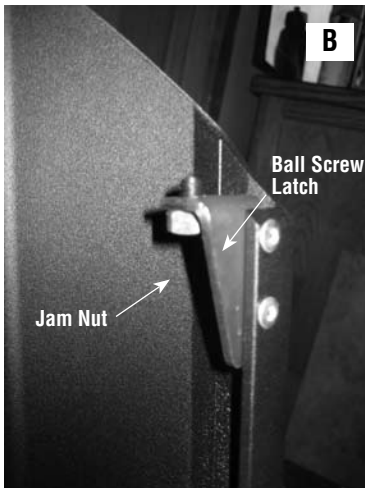
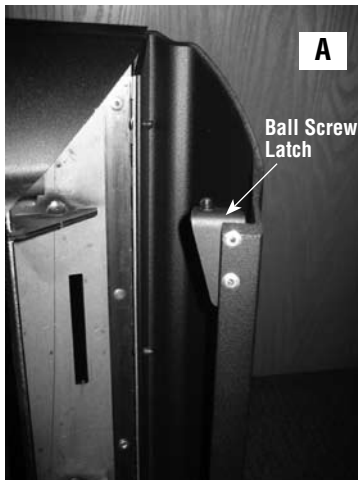

NOTE: DIAGRAMS AND ILLUSTRATIONS ARE NOT TO SCALE

GAS LINE INSTALLATION

We recommend that a qualified individual such as a plumber or gas fitter be used to correctly size and route the gas supply line to the appliance. Installing a gas supply line from the fuel supply to the appliance involves numerous considerations of materials, protection, sizing, locations, controls, pressure, sediment, and more. Certainly no one unfamiliar and unqualified should attempt sizing or installing gas piping. Never use galvanized or plastic pipe.

The gas supply line should be plumbed from the fuel source to the area where the appliance is to be installed per requirements outlined in NFPA 54 - latest edition (USA) or CAN/CSA B149.1 - latest edition (Canada) and per local codes.

The insert comes with an 8 inch (203 mm) nipple attached to the supply side of the gas valve. After connecting the gas line, all joints in the line and connections at the valve should be checked for leaks using a gas leak test solution before final positioning of the unit.

Gas Pressure Requirements

It is important to check the gas pressure during the initial installation of the insert and ensure there are no operating problems. This insert will not function properly unless the required gas pressure is supplied.

Two pressure taps are provided on the insert's valve to check gas pressures (see **Figure 37 on Page 22**). The taps are located to the left of the on/off/pilot knob. The top tap is the inlet (supply) pressure side. To check inlet pressure (with the fireplace insert burning), insert a small regular screwdriver into the tap and turn a half turn counterclockwise. Cover the tap with the line from a manometer and check the pressure. Close the tap gently but securely after completing the check. The manifold (outlet) tap is below the inlet tap. To check manifold pressure (with the insert burning at the high burn setting) insert a small phillips screwdriver into the tap and turn a half turn counterclockwise. Cover the tap with the line from the manometer and check the pressure. Again, close the tap gently but securely after completing the check. Check the taps for gas leaks with a gas leak test solution and retighten if necessary.

If the pressure is too low, make sure the gas supply line is large enough, the supply regulator is properly adjusted, and the total gas load for the residence does not exceed the amount supplied.

IMPORTANT NOTE: If propane is used, be aware that if the tank size is too small (i.e. under 100-lbs, if this is the only gas appliance in the dwelling. Ref. NPFA 58), there may be loss of pressure, resulting in insufficient fuel delivery (which can result in sooting or other malfunctions). Any damage resulting from an improper installation, such as this, is not covered under the limited warranty.

These appliances and their individual shut-off valves *must be disconnected* from the gas supply piping system during any pressure testing of that system at pressures **greater than** 1/2 psig (3.5 kPa).

These appliances must be isolated from the gas supply piping system (*by closing their individual manual shut-off valve*) during any pressure testing of the gas supply piping system at test pressures equal to or **less than** 1/2 psig (3.5 kPa).

Tables 10 and 11 show the units' gas pressure requirements for these appliances.

Inlet Gas Supply Pressure			
Fuel #	Minimum	Maximum	Desired
Natural Gas	5" WC/ps. C.E (1.25 kPa)	10.5" WC/ps. C.E (2.61 kPa)	7" WC/ps. C.E (1.74 kPa)
Propane	10.5" WC/ps. C.E (2.61 kPa)	13.0" WC/ps. C.E (3.23 kPa)	11" WC/ps. C.E (2.74 kPa)

Table 10

Manifold Gas Supply Pressure		
Fuel #	Low	High
Natural Gas	(Lo) 1.3" WC/ps. C.E (.32 kPa)	(Hi) 3.5" WC/ps. C.E (.87 kPa)
Propane	(Lo) 5.4" WC/ps. C.E (1.35 kPa)	(Hi) 10.0" WC/ps. C.E (2.49 kPa)

Table 11

LP and Natural Gas Supplies

Your Shoreline™ can be operated with either natural gas or liquid propane (LP). It is shipped from the factory for use with only natural gas. The fireplace insert must always be operated with the same gas as specified on the label unless converted by a qualified service technician as per this manual.

Also check the orifice size on the label located below the Shoreline insert. It must be the correct size for the fuel and altitude.

OPERATING INSTRUCTIONS

Pre-Lighting Checklist

Be sure to check these items before the initial lighting of the insert:

- The insert gas label corresponds to the gas supply available - that is "natural gas" for natural gas or "LP gas" for LP gas.
- Gas pressure has been checked carefully.
- All gas fittings have been checked for leaks.
- All clearances to combustibles have been met.
- All combustible materials have been removed from the area in front of the insert.
- All vented areas of the insert face are unobstructed.
- House is ventilated to clear initial curing odor.
- All packaging materials have been removed from the fire-box.
- While insert is cool, fingerprints or other marks should be cleaned from any surfaces with a soft cloth. Marks left on these surfaces may become etched into the finish if not removed prior to burning the unit.
- Brick panels and log set have been installed.
- The glass door is in place and is properly sealed.







CAUTION

Your Shoreline™ gas appliance must always be operated with glass door in place.

Lighting Instructions

STOP! Read the safety information on the front cover of the manual before proceeding.

1. Open the right side access door. Ensure the gas supply shut-off cocks are open and ON/OFF Rocker Switch is "OFF". If equipped with a thermostat, set it to the lowest setting.
2. Turn off all electrical power to the appliance.
3. Push in the gas control knob slightly and turn clockwise  to "OFF".
NOTE: The knob cannot be turned from "PILOT" to "OFF" unless the knob is pushed in slightly. Do not force.
4. Wait five (5) minutes to clear out any gas. If you smell gas, STOP! Follow instructions on the front cover of this manual. If you do not smell gas continue.
5. Locate the pilot assembly by looking at the rear center of the burner, behind the large center log. A blue flame will be seen when the pilot is lit.
6. Turn the gas control knob counterclockwise  to the "PILOT" position.
7. Push the knob all the way in and hold in that position. Immediately light the pilot by pressing the igniter button several times until pilot is lit. Continue to hold the knob in for about 30 seconds after the pilot is lit. Release knob and it will pop back out. Pilot should remain lit. If it goes out, repeat steps 4-8 holding knob in an additional 15 seconds after pilot is lit.
- If knob does not pop out when released, stop and immediately call your service technician or gas supplier.
- If the pilot will not stay lit after several tries, turn the gas control knob to "OFF" and call your service technician or your gas supplier.
8. After pilot is lit, turn gas control counterclockwise  to "ON". Knob can only be turned "ON" if the knob has popped out.
9. To turn burner on, turn "ON/OFF" rocker switch to "ON" or set the thermostat to the desired temperature above room temperature.
10. Adjust the flame height (and heat output) by turning the flame height knob clockwise  for reduced flame  and counterclockwise for full flame.
11. Set the blower to the desired air flow after it turns on when the appliance reaches operating temperature.

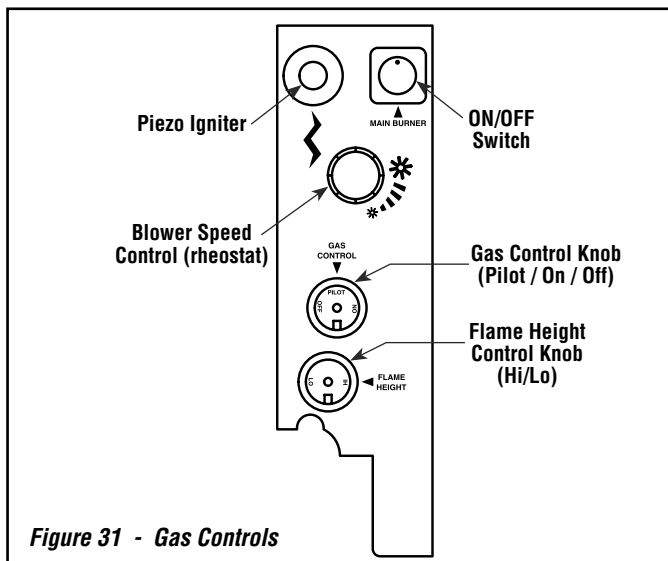

Figure 31 - Gas Controls

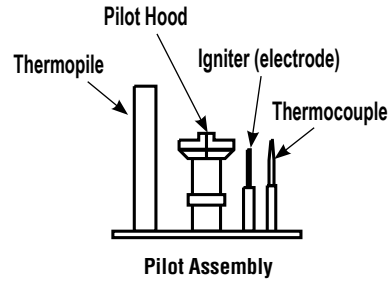



Figure 32 - Pilot Assembly

To Turn Off Gas To Appliance

1. Turn off the "ON/OFF" rocker switch and/or thermostat (if installed).
2. Turn off electric power to the appliance if service is to be performed.
3. Turn gas control knob clockwise  to "OFF". Do not force.

This appliance needs fresh air for safe operation and must be installed so there are provisions for adequate combustion and ventilation air. See Installation and Operation Manual accompanying appliance.

Operation of this appliance when not connected to a properly installed and maintained venting system can result in carbon monoxide (CO) poisoning and possible death.

Shutdown Procedure

1. To turn off the burner, switch the rocker switch to "OFF" or adjust the thermostat to a setting below room temperature (if installed). The pilot will remain lit for future burner ignition.

For complete shutdown: See "To Turn Off Gas To Appliance" above.



WARNINGS

- **Improper installation, adjustment, alteration, service or maintenance can cause injury or property damage. For assistance or additional information, consult a qualified installer, service agency or your gas supplier.**
- **Operation of this appliance when not connected to a properly installed and maintained venting system can result in carbon monoxide (CO) poisoning and possible death.**
- **Carbon monoxide poisoning – early signs of carbon monoxide poisoning resemble the flu with headaches, dizziness, or nausea. If you have these signs, get fresh air at once! Have the heater inspected by a qualified service technician. Some people are more affected by carbon monoxide than others. These include pregnant women, people with heart or lung disease or anemia, those under the influence of alcohol, and those at high altitudes.**

Flame Appearance and Sooting

Your Shoreline™ fireplace insert is designed for maximum heating efficiency. Therefore, upon lighting of the main burner the flames will be semi-transparent or “bluish.” After 10-20 minutes of operation the logs will heat up and the flames will become a yellow/orange color. If after 20 minutes the flame stays lowered blue, or if the flame is orange with evidence of sooting (black tip), the air shutter may require adjustment.

Adjusting the insert to cause the flames to turn orange sooner may result in poor combustion, sooting, and a hazardous situation. See **Figures 33 and 34** showing proper flame appearance.

Sooting is indicated by black puffs developing at the tips of very long orange flames. Sooting results in black deposits forming on the logs, appliance inside surfaces and on exterior surfaces adjacent to the vent termination. Sooting is caused by incomplete combustion in the flames and lack of combustion air entering the air shutter opening. To achieve a warm yellow to orange flame that does not soot, the shutter opening must be adjusted between these two extremes.

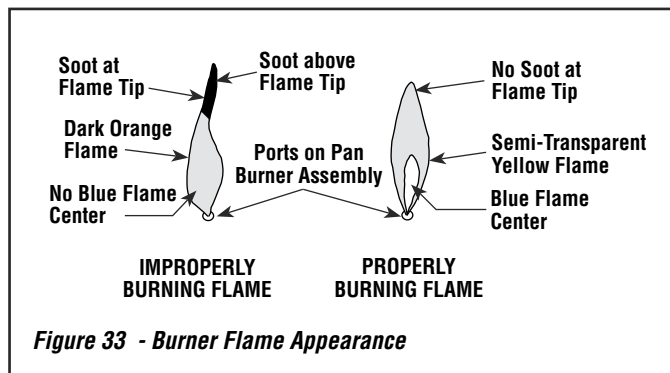

Air Shutter Adjustment

The Shoreline has an air shutter control lever located below the front door, left of the center point of the gas insert. The lever is linked to the primary air shutter on the main burner. The air shutter regulates the amount of primary air the burner receives and therefore how clean the insert burns. The air shutter should only be adjusted by a qualified gas technician. The insert should burn for about 15 minutes with the logs installed before adjusting the air shutter. More air will result in shorter flames and less color, less air will result in bigger flames and more color. To adjust the air shutter, move the slide adjustment from side to side (see **Figure 35**). Moving the air shutter lever to the right opens the air shutter (more air). Moving the air shutter lever to the left closes the air shutter (less primary air).

CAUTIONS

- Carbon will be produced if the air shutter is closed too much. Any damage due to carboning resulting from improperly setting the air shutter is not covered under the warranty.
- The air shutter control arm and nearby appliance surfaces are hot. Exercise caution to avoid injury while adjusting flame appearance.
- The air shutter should never be set so as to make the tips of the flames sooty or create sooting on the viewing glass, logs, or heat exchanger. If soot begins to form after burning, the air shutter should be opened gradually until the sooting condition stops. Gas quality and gas pressure may vary, which can affect the burning characteristics of the insert.

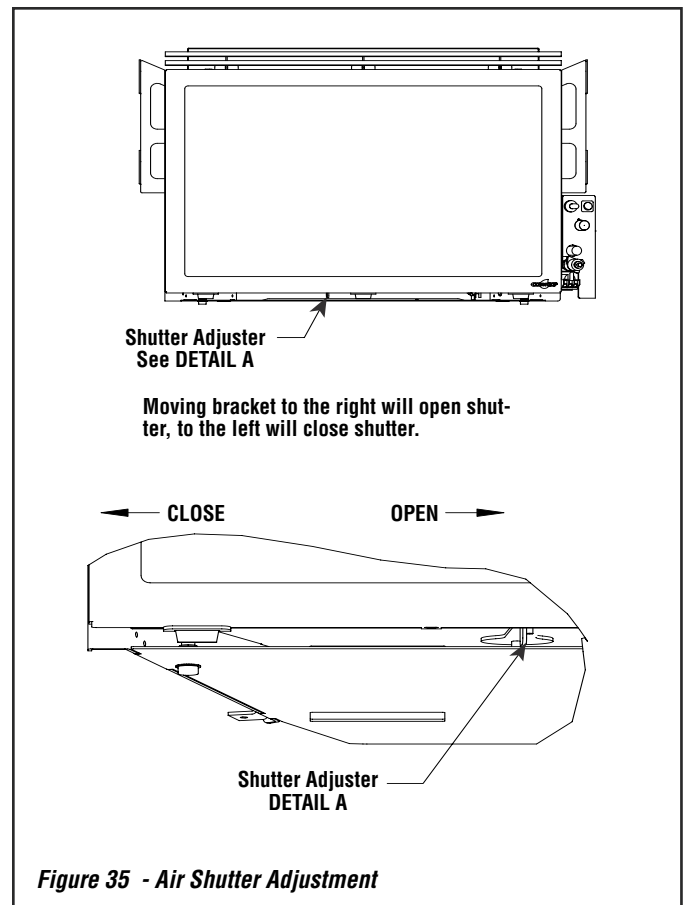

Shoreline™ Main Burner Operation

Your Shoreline fireplace insert comes with an “ON/OFF” rocker switch used to turn the burner on and off while the pilot is on. The rocker switch is located in the control panel above the blower rheostat switch and to the left of the igniter. This is all located behind the right side surround.

A wall-mounted switch, a millivolt wall thermostat, or a remote control, can be used to supplement the rocker switch. The gas valve is powered by millivolts generated by the pilot assembly. This millivolt system is very sensitive to electrical resistance, therefore, make sure all connections are tight, clean, and free from corrosion. Do not splice any millivolt wires. Consult **Table 12** to determine the proper gage of wire for the thermostat or wall switch connections. This chart refers to the total length of the wire (out to the switch and back). The thermostat must be a millivolt type. A 24-volt furnace thermostat will not work. Never hook up household current - 120 Volts - to the millivolt system. It is not recommended to hook up any more than two switches to the fireplace insert (for example a rocker switch and a wall thermostat). Additional switches may affect the system resistance and increase the chance of the burner not igniting. Follow the instructions included with the thermostat or remote control for wiring.

The thermostat, remote control, and rocker switch will turn the burner on and off independently. Be sure to set the rocker switch to the “OFF” position when using the thermostat or remote control and set the thermostat or remote control to the lowest temperature when you wish to use the rocker switch only, otherwise one may override the other. If a remote thermostat is to be used with the insert, do not place the receiver under the firebox.

Care should be taken to ensure any installed wires from thermostat do not come in contact with the hot surfaces of the firebox.

IMPORTANT NOTE: If a wall thermostat is to be installed, install the thermostat per the manufacturers instructions, provided with the thermostat. Failure to follow manufacturers instructions could result in a malfunction. Pay special attention to the thermostat location requirements. If the location requirements are not adhered to the appliance, erratic operation or failure may occur. Do not mount the thermostat where it may be affected by:

- Radiant heat from the stove, fireplaces, sun or other heat sources.
- Drafts or dead spots behind doors or in corners.
- Hot or cold air from ducts.

Thermostat Wire	
Wire Size	Maximum Length
12 Gage	100 Feet
14 Gage	64 Feet
16 Gage	40 Feet
18 Gage	25 Feet
20 Gage	16 Feet

Table 12

Millivolt Control System

This Shoreline fireplace insert operates on a millivolt control system. As such, no additional power supply is needed for the Shoreline insert to heat. The pilot assembly contains a thermocouple, that when heated by the pilot flame, generates electricity (millivolts- mV=1/1000 of a volt) which opens a valve allowing gas to flow to the pilot assembly. The pilot assembly also contains a thermopile, that when heated by the pilot flame, generates electricity that flows to terminal #1 (labeled TH/TP) on the gas valve. When the electricity is conducted from terminal #1 through the on/off switch, thermostat, or receiver of the remote control to terminal #3 (labeled TH) on the gas valve, the main burner will ignite. See **Figures 37 and 38**.

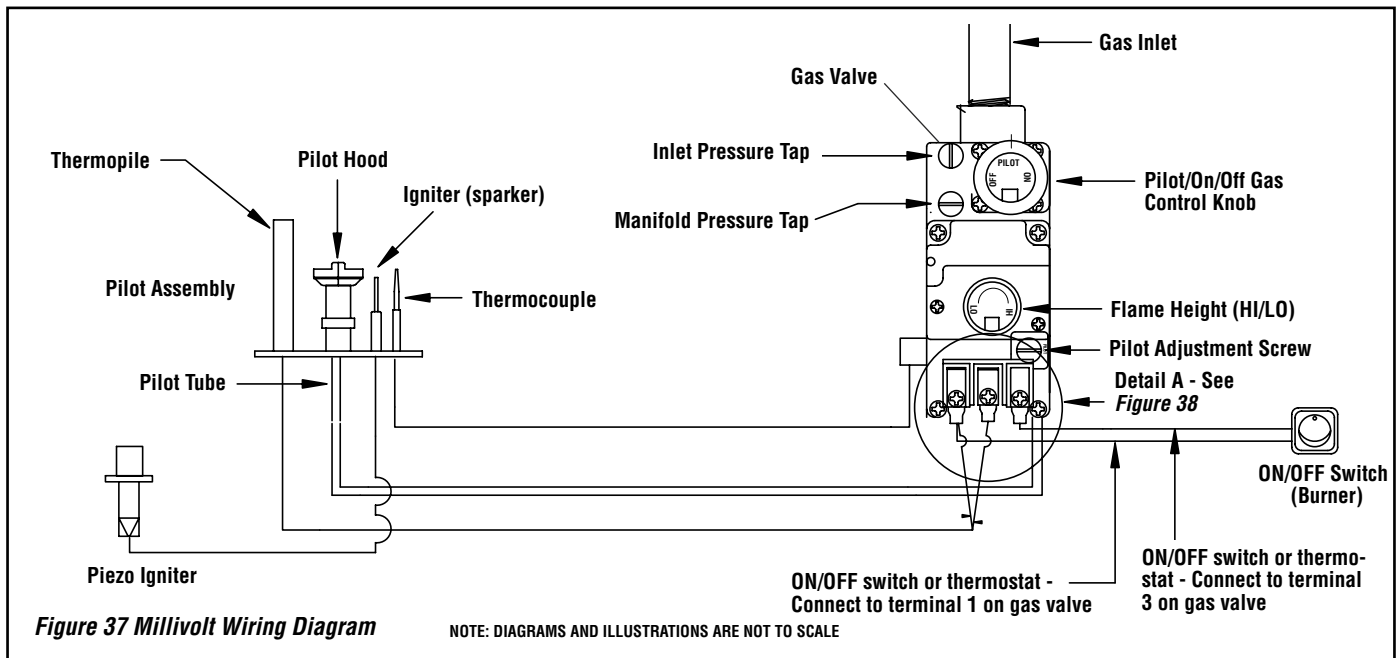
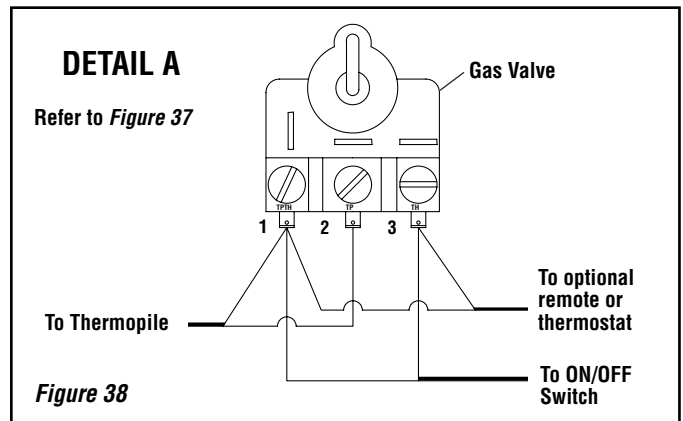

NOTE: DIAGRAMS AND ILLUSTRATIONS ARE NOT TO SCALE

MAINTENANCE AND SERVICING

! WARNINGS

- Turn off gas and electrical power before servicing the appliance.
- Do not attempt to touch the front enclosure glass with your hands while the fireplace is in use.
- Any safety guard or screen removed for servicing the appliance must be replaced prior to operating the appliance.

! CAUTION

Wear gloves and safety glasses for protection while doing required maintenance.

! IMPORTANT

Always verify proper operation after servicing.

Maintenance Checklist

The following should only be performed by a qualified service technician.

1. Annual inspection should be made and the following checks performed:

- ❑ When unit is cool, remove glass and inspect burner for dirt, soot, and lint accumulations, and remove if necessary. If excessive soot accumulation is present on burner, have a qualified service technician adjust the burner for proper combustion.
- ❑ Clean inside of glass with gas fireplace glass cleaner. NEVER attempt to remove or clean the glass when the unit is hot.
- ❑ Check the hot air outlet vents for lint or other accumulations. Never block or restrict vent openings, obstruct flow of ventilation air, or use vents other than Lennox Hearth Products products.
- ❑ Check that the chimney and its outlet are open and free of soot, blockage, or debris.
- ❑ Check gaskets once a year. Gaskets must be tight. Replace if necessary.
- ❑ Inspect the pilot system for proper flame (see *Figure 39*). NEVER ADJUST THE PILOT until after the gas pressure has been checked and the supply lines have been completely bled (this may take an hour or more when bleeding through the pilot). All pilots are checked and burned at the factory prior to shipment. The pilot adjustment screw is located below the ON/OFF/PILOT control knob. Remove the pilot adjusting cover with a flat-bladed screwdriver to access the pilot adjusting screw. Adjust the pilot screw to properly size the flames. The flames should directly contact the thermopile and extend across the main burner ports. Be careful not to back the screw out of its threads. Replace the cover and check for gas leaks using a gas leak test solution.
- ❑ Check that the area around the insert is kept clear and is free of combustible materials, gasoline, and other flammable vapors and liquids.
- ❑ Check the millivolt system as per *Table 13*.

2. The viewing glass should be cleaned periodically (see Glass Maintenance).

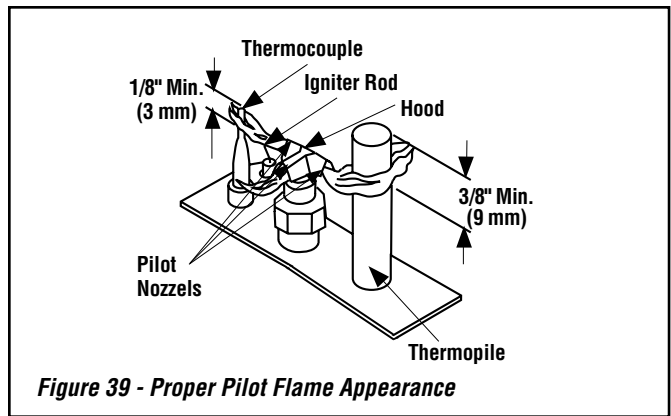

Figure 39 - Proper Pilot Flame Appearance

Check Test	To Test	Connect Meter Leads to Terminals	Thermostat Connects	Meter Reading Should Be
A	Complete System	2 & 3	Closed	100 MV or More
B	Thermopile Output	1 & 2	Open	Greater Than 325 MV
C	System Resistance	2 & 3	Closed	2.5 Ohms

Table 13

Glass Maintenance

! WARNING

- Do not operate appliance with the glass panel removed, cracked, or broken. Do not remove glass door while the insert is hot. Replacement of the glass door should be done by a qualified service technician.
- Handle glass door with extreme care! The glass door assembly is susceptible to damage. Do not scratch while handling or while reinstalling.

! IMPORTANT

Do not use abrasive cleaners on glass. Never clean the glass when it is hot.

Glass Maintenance (continued)

Cleaning: Note: Clean glass after first two weeks of operation (after Burn-In period is over).

The viewing glass should be cleaned periodically to remove any build-ups caused from the following:

- During start-up, it is normal for condensation to form on the inside of the glass (this condensation and fog will usually disappear in a few minutes). This can cause lint, dust and other airborne particles to cling to the glass surface.
- Initial curing of the high temperature paint and burning off of lubricants used in the manufacturing process may result in a film on the glass.
- A white coating may form on the glass as a result of impurities and minerals in the fuel.

It is recommended that the glass be cleaned two or three times during each heating season, depending on the circumstances present.

Use one of the following to clean glass:

- Non-ammonia based household cleaner
- 50%-50% mix of white vinegar and water
- gas stove glass cleaner

Replacement: The glass in the insert door cannot be replaced separately. Should the glass be damaged, the entire glass, gasket, and metal frame assembly must be replaced as a unit. This replacement glass assembly is available from your Lennox Hearth Products dealer. The glass is neo-ceramic and alternative types must not be used.

Door Removal



CAUTION

Do not slam or strike glass door or damage may occur.

Do not remove the glass door while the insert is hot. To remove the glass door, pull forward and up on the top latches. Lift the glass door up and off the lower spring latch. Be careful not to damage or scratch the glass while handling. To reinstall the glass, reverse the removal steps. Do not operate the insert with the glass removed.

Blower Removal

CAUTION: Label all wires prior to disconnection when servicing controls. Wiring errors can cause improper and dangerous operation.

IMPORTANT: Verify proper operation after servicing (see the blower wiring diagram in *Figure 36 on Page 21*).

1. Unplug the power supply cord from the electrical outlet prior to removing the blower. The blower can be accessed through the back wall of the firebox.
2. Remove the insert face, glass door, log set, and brick panels. All of these items are fragile so handle them with care.
3. Next, remove the nine allen head screws around the outside of the panel fastened to the back wall of the firebox.
4. Rotate the top of this panel toward the front, remove the two wires connected to the blower, and then lift the panel with the blower attached out of the firebox.

To reinstall the blower, repeat these steps in the reverse order.

Small Area Paint Touch-up

The finish of the insert body and surround is a high-temperature stove paint. Only use factory supplied high-temperature paint for touch-ups, cat. no. 70K99.

Do not attempt to repaint the insert until the finish is completely cured (see **Burn-In Period** on *Page 21*). If the surface later becomes stained or marred, it may be lightly sanded and touched up with spray paint.

Paint is available at your local authorized Lennox Hearth Products dealer. Never attempt to paint a hot insert.

Inspect Wiring

Inspect and clean all wire connections. Ensure that there is no melting or damage. Inspection should include:

- Terminals at the valve
- On/Off switch
- Wall thermostat, remote control, or wall switch kit (optional parts)

Refer to wiring diagrams on *Pages 21 and 22*.

Fuel and BTU Conversion

Converting your Shoreline™ gas insert between natural gas (40,000-33,000 BTU's) and LP (37,500-33,000 BTU's) can be accomplished by installing a conversion kit (valve regulator just for fuel conversion and burner orifice). Only a qualified service technician should perform the conversion.

Fuel Conversion Kits

Please see instructions provided with conversion kit. See *Page 33* for ordering information.

MAINTENANCE SCHEDULE

ANNUALLY (Before the onset of the Burning Season)

MAINTENANCE TASK	ACCOMPLISHING PERSON	PROCEDURE
Inspecting/Cleaning Burner, Logs and Controls	Qualified Service Technician	Inspect valve and ensure it is properly operating. Check piping for leaks. Vacuum the control compartment, fireplace logs and burner area.
Check Flame Patterns and Flame Height	Qualified Service Technician	Refer to Figures 33 and 34 on Page 20 and verify the flame pattern and height displayed by the appliance conforms to the picture. Flames must not impinge on the logs.
Inspecting/Cleaning Pilot	Qualified Service Technician	Refer to Figure 39 on Page 23 . Remove any surface build-up on pilot assembly. Wipe the pilot nozzles, igniter electrode and hood. Ensure the pilot flame engulfs the thermopile and thermocouple as shown.
Checking Vent System	Qualified Service Technician	Inspect the vent system at the top and at the base (within the firebox) for signs of blockage or obstruction. Look for any signs of dislocation of the vent components.
Appliance Checkout	Qualified Service Technician	Perform the appropriate appliance checkout procedure detailed in this manual.
Replacing Rockwool Ember Materials	Homeowner/Qualified Service Technician	Remove old ember materials and vacuum the ember (rockwool) placement area. Place new rockwool as described on Page 15 .

PERIODICALLY (After the Burning Season)

MAINTENANCE TASK	ACCOMPLISHING PERSON	PROCEDURE
Cleaning Firebox Interior	Homeowner	Carefully remove logs, rockwool and lava rock. Vacuum out interior of the firebox. Clean firebox walls and log grate. Replace logs, rockwool and lava rock as detailed in this manual.
Check Flame Patterns and Flame Height	Homeowner	Refer to Figures 33 and 34 on Page 20 and verify the flame pattern and height displayed by the appliance conforms to the picture. Flames must not impinge on the logs.
Checking Vent System	Homeowner	Inspect the vent system at the top and at the base (within the firebox) for signs of blockage or obstruction. Look for any signs of dislocation of the vent components.
Cleaning Front Door Window	Homeowner	Clean as necessary following the directions provided in this manual. DO NOT TOUCH OR ATTEMPT TO CLEAN GLASS WHILE HOT.

TROUBLESHOOTING

NOTE: When troubleshooting the gas control system, be sure the external gas shut off valve, located at the gas supply inlet is in the “ON” position.
IMPORTANT: Call your gas supplier or plumber for additional help with any gas control problem. Valve system troubleshooting should only be accomplished by a qualified service technician.

SYMPTOM	PROBABLE CAUSE	CORRECTIVE ACTION
Thin black coating (soot) forms on the viewing glass, logs, or firebox	<p>Improper log or ember placement</p> <p>Improper air shutter setting</p> <p>Not enough combustion air</p>	<p>See Brick Panel and Log Set Installation on Pages 13 through 15. If there is soot in one specific location, the rockwool below this location needs to be adjusted. This can be done by pulling embers forward slightly. If the flames have soot tails, the shutter will need to be opened.</p> <p>If sooting continues open air shutter (see Air Shutter Adjustment on Page 20)</p> <p>Check for debris obstructing air flow in valve compartment under insert or in front of lower venting.</p>
Humming or whistling coming from insert.	<p>Normal operating noise</p> <p>Obstructed orifice opening</p>	<p>See Quiet Operation on Page 21. The noise may be reduced by slightly turning down the flame. Turning the flame down will reduce the heat output of the insert.</p> <p>If noise is excessive or is “whistling” have your gas supplier check the regulator and orifices and replace if necessary.</p>
A change in flame appearance or burner operation.	<p>A change in gas pressure</p> <p>Improper ember placement</p>	<p>Have your gas supplier check for correct gas pressure (7" W.C. / po. C.E. [1.74 kPa] natural gas; 11" W.C. / po. C.E. [2.74 kPa] LP gas). NOTE: NEVER BLOCK OR OBSTRUCT AIR INTAKE OR OUTLET VENTS.</p> <p>See Brick Panel and Log Set Installation on Pages 13 through 15.</p>
Spark igniter will not light pilot after repeated tries.	<p>No gas supplied to unit or air in line</p> <p>Defective igniter (no spark at electrode)</p> <p>Defective or misaligned electrode at pilot (spark at electrode)</p>	<p>Check gas supply. To purge, hold in gas cock on valve for 1-2 minutes and try again.</p> <p>Check for spark at electrode and pilot, if no spark and electrode wire is properly connected, replace igniter and igniter wire.</p> <p>Using a match, light pilot. If pilot lights, turn off pilot and trigger the igniter again. If pilot lights, an intermittent gas/air supply may be the problem, if longer purge will not light - check gap between electrode and pilot - should be 1/8 inch (3 mm) to have a strong spark. If OK, replace pilot.</p>
Pilot will not stay lit after carefully following lighting instructions.	<p>Low gas inlet pressure</p> <p>Defective thermopile</p> <p>Defective automatic valve operator</p>	<p>Check inlet pressure and adjust pilot if necessary.</p> <p>Be sure wire connections from thermopile are tight at gas valve terminals and at vent safety snap switch.</p> <p>Either rocker switch or thermostat wires may be grounded. Remove wires from valve terminals. If pilot stays lit, trace switch wiring for a ground. May be grounded to insert or gas supply.</p> <p>Check open circuit millivolt output of thermopile. Reading should be greater than 325mV. Also check thermopile wire for kinks that can cause loss of mV. Replace faulty thermopile if wire is okay and reading is less than 325mV.</p> <p>Turn valve knob to “ON” and thermostat (if installed) to 90°. Millivolt meter should read greater than 100 mV. If reading is OK and burner does not turn on, replace gas valve (qualified service technician only).</p>
Main burner will not burn.	<p>Pilot has gone out</p> <p>Rocker switch, thermostat, or wires defective</p> <p>Thermopile may not be generating sufficient millivolts</p>	<p>See Lighting Instructions.</p> <p>Disconnect rocker switch and thermostat wires at terminals 1 and 3 on valve. Jumper across from 1 to 3 with pilot lit. If burner comes on either rocker switch, thermostat, or wiring is not functioning.</p> <p>Check thermopile with millivolt meter (see Maintenance and Servicing), recheck symptom #2.</p>

NOTE: DIAGRAMS AND ILLUSTRATIONS ARE NOT TO SCALE

SHORELINE™ REPLACEMENT PARTS LIST - MODELS SHR33 & SHR40

Item #	Part/Cat. No.	Description
1	H5722	Firebox Assembly
2	H5723	Air Intake Assembly
3	H5724	Blower Box Assembly w/blower
4	H5725	Flue Collar Assembly
5	H5726	Blower Snap Switch Assembly
6	H5727	Rear Leveling Leg Assembly
7	H5729	Outer Bottom Assembly
8	H3140	Burner Assembly
9	H5731	Pilot Assembly with Shield
10	H5732	Main Orifice - NG33
10	H5733	Main Orifice - NG40
10	H5734	Main Orifice - LP33
10	H5735	Main Orifice - LP40
11	H5736	Bulkhead Assembly
12	H5737	Cassette Plate Assembly
13	H5738	Valve Assembly
14	H5739	Air shutter Assembly
15	H5740	Cassette Assembly
16	H5741	Louver Assembly
17	H5742	Blower Rheostat

18	H5743	Control panel/Valve cover
19	H5744	On/Off Switch
20	H5745	Piezo Igniter w/nut
21	H5746	Door Assembly
22	H5747	Log Set Assembly
23	H5748	Brick Panel Brackets
24	H5749	Surround Hanging Brackets
25	H5750	Upper Air Deflector
26	H5751	Blower Ducting
27	H5752	Wire Grommets
28	H5753	Burner Support
29	H5754	Front Leveling leg Assembly
30	H5755	Gasket kit
31	H5756	Surround Hinge
32	H5757	Ball Screw Mount Assembly
33	H5758	Ball Screw Catch Assembly
34	H5759	Surround Spacer Kit - Small
35	H5760	Surround Spacer Kit - Large
36	H5761	Extrusion Kit - 3 piece - Small
37	H5762	Extrusion Kit - 3 piece - Large
38	H5763	Extrusion Kit - 4 piece - Small
39	H5764	Extrusion Kit - 4 piece - Large

PART IDENTIFICATION

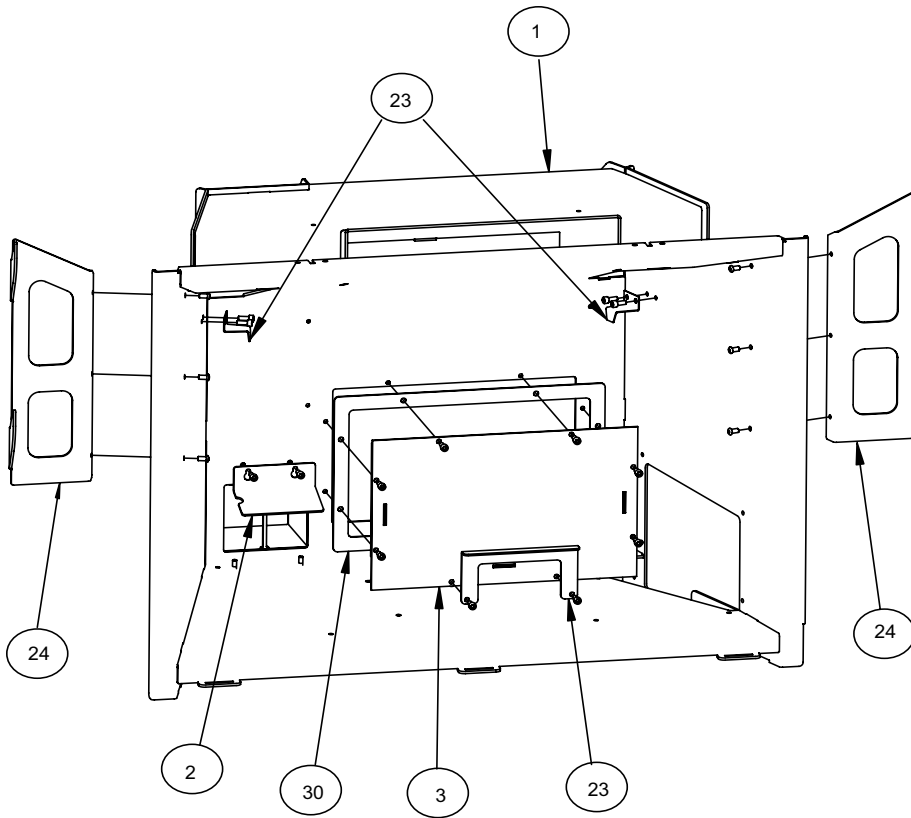

Item #	Description
1	Firebox Assembly
2	Air Intake Assembly
3	Blower Box Assembly
4	Flue Collar Assembly
5	Blower Snap Switch Assembly
23	Brick Panel Brackets
24	Surround Hanging Brackets
25	Upper Air Deflector
26	Fan Ducting
27	Wire Grommets
30	Gasket Kit

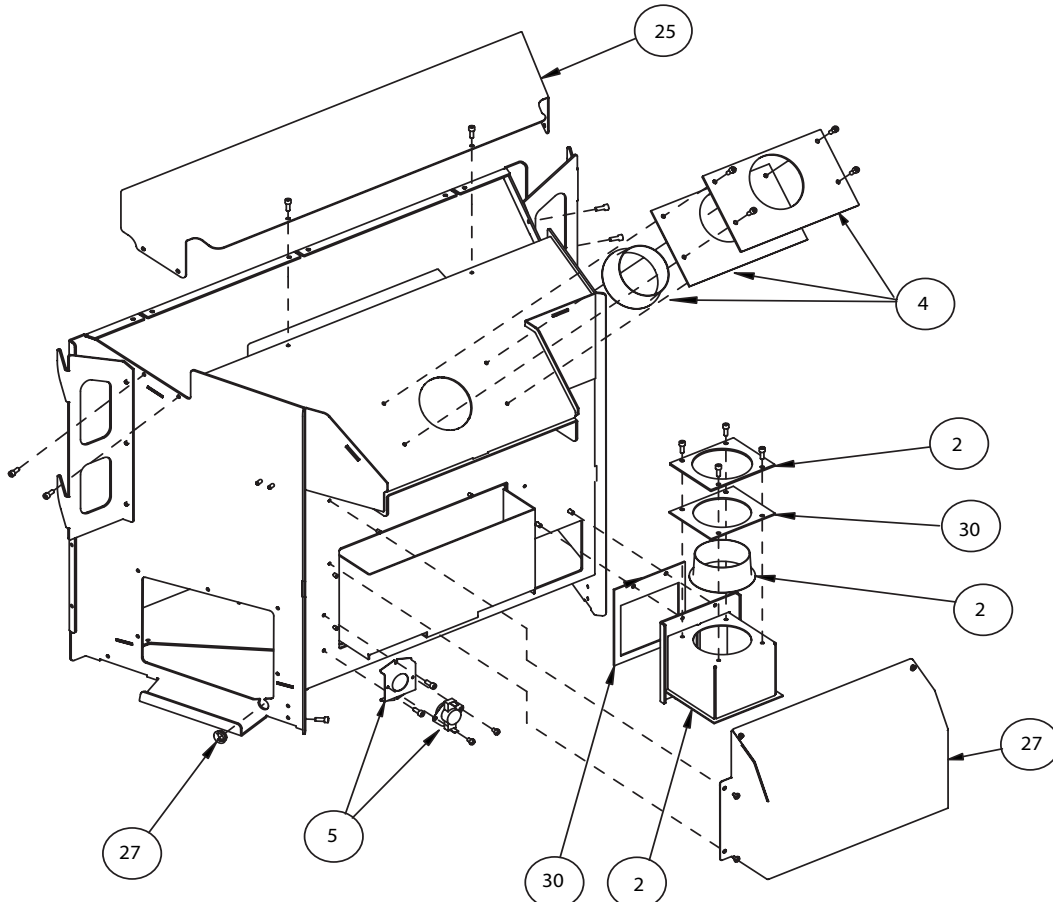

NOTE: DIAGRAMS AND ILLUSTRATIONS ARE NOT TO SCALE

PART IDENTIFICATION

Pilot Cassette Assembly

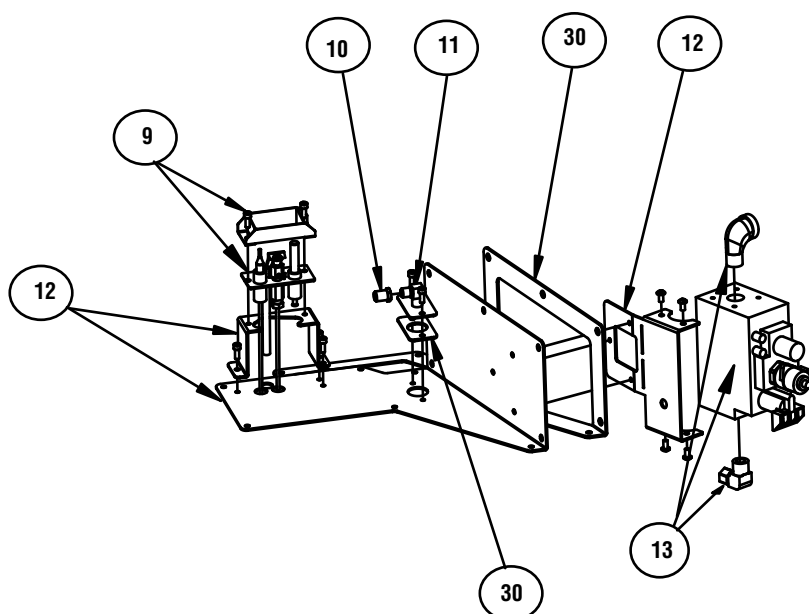

Item #	Description
9	Pilot Assembly w/Shield
10	Main Orifice
11	Bulkhead Assembly
12	Cassette Plate Assembly
13	Valve Assembly
14	Air Shutter Assembly
15	Cassette Assembly
30	Gasketing

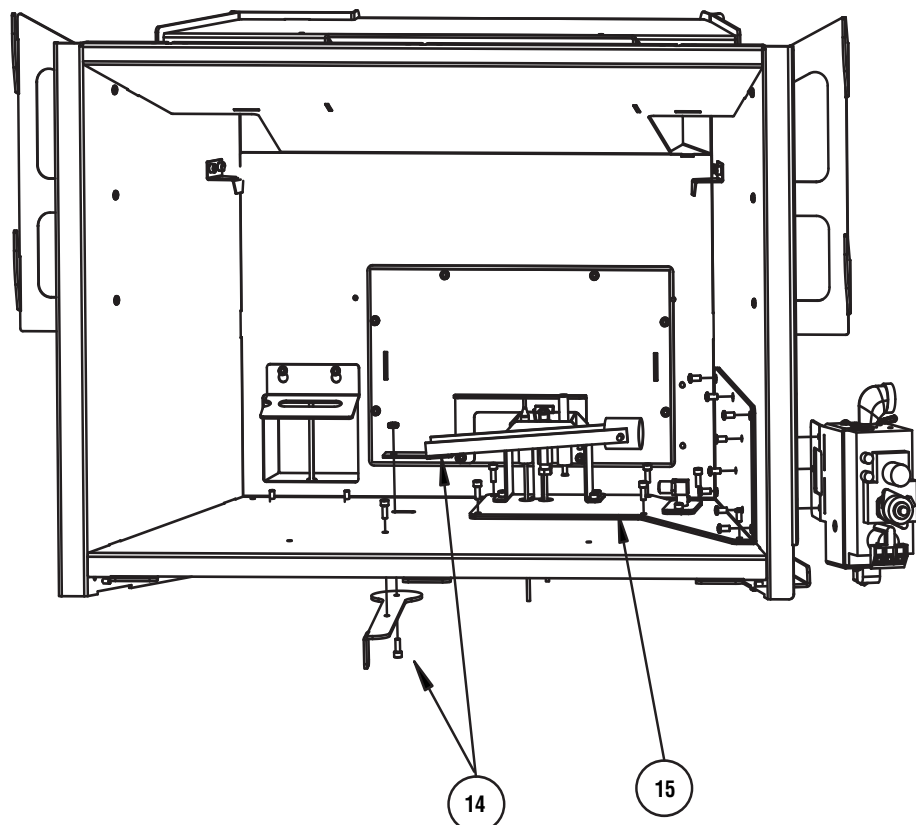

NOTE: DIAGRAMS AND ILLUSTRATIONS ARE NOT TO SCALE

PART IDENTIFICATION

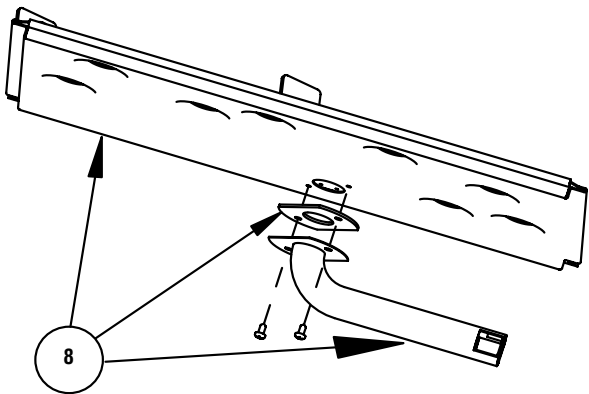
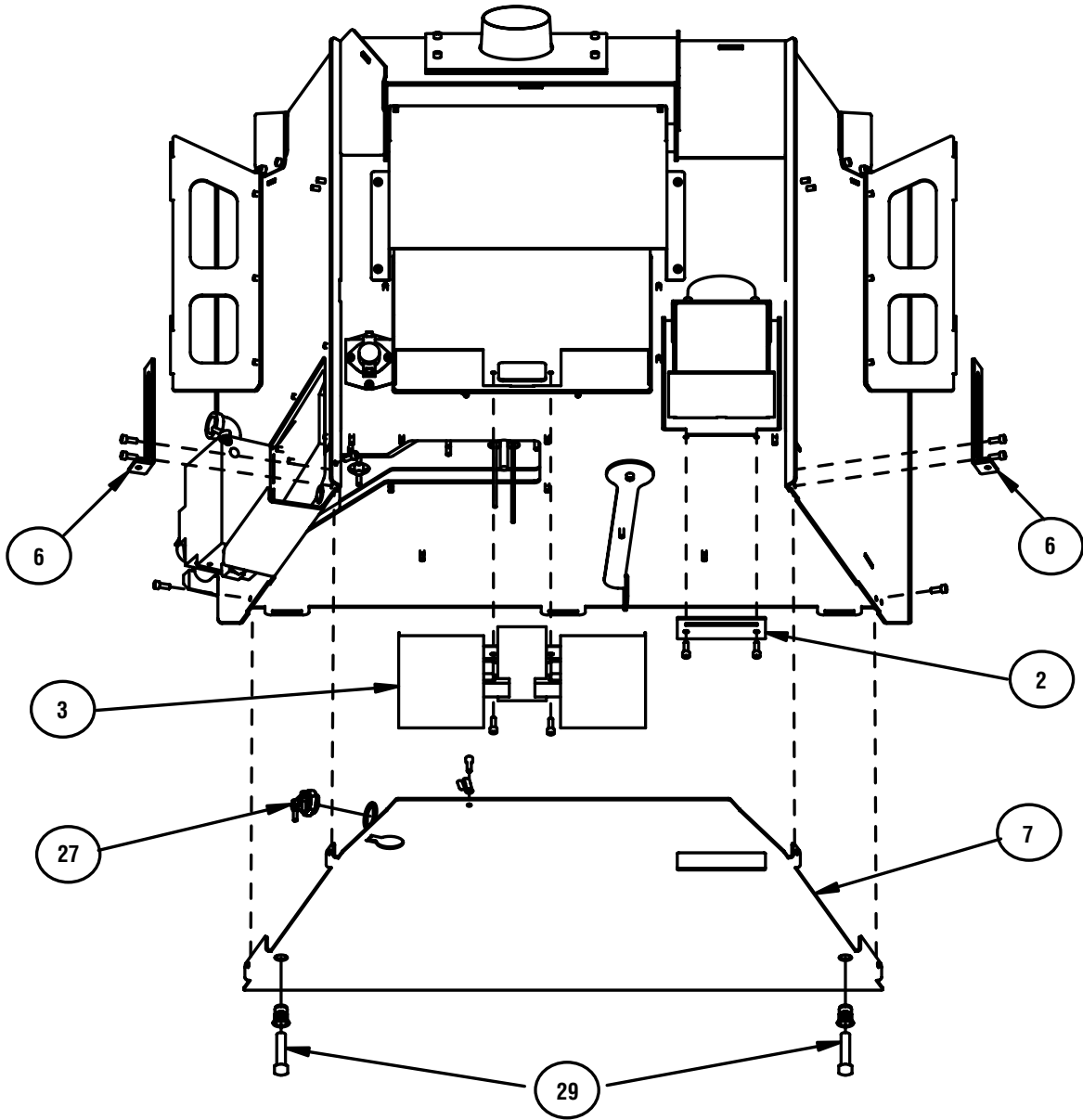

Item #	Description
2	Air Intake Assembly
3	Blower Box Assembly w/Blower
6	Rear Leveling Leg Assembly
7	Outer Bottom Assembly
8	Burner Assembly
27	Wire Grommets
29	Front Leveling Leg Assembly

PART IDENTIFICATION

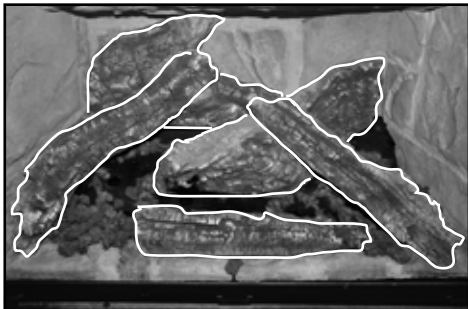
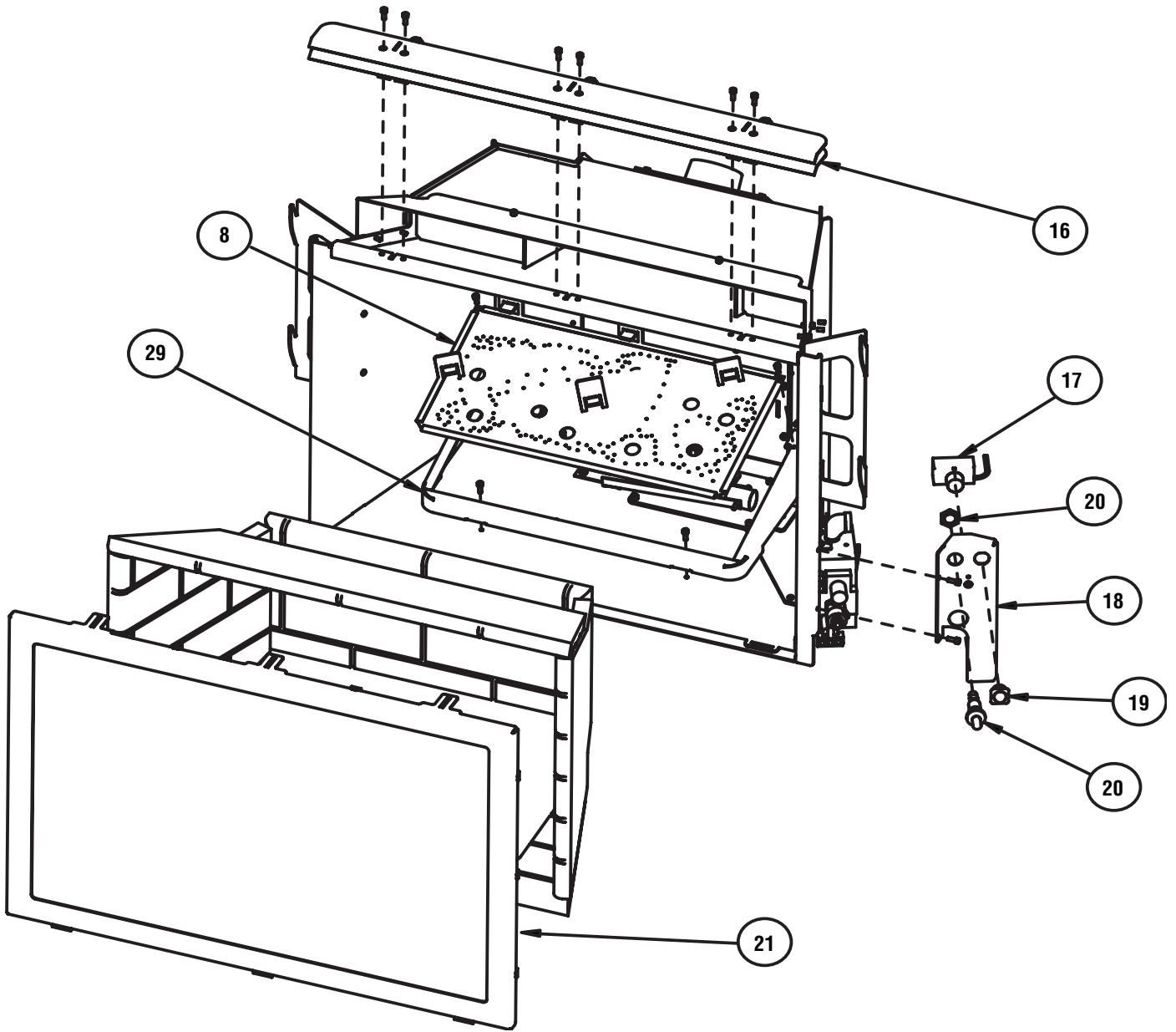

Ceramic Log Set

Item #	Description
8	Burner Assembly
16	Louver Assembly
17	Blower Rheostat
18	Control Panel/Valve Cover

Item #	Description
19	On/Off Switch
20	Igniter w/nut
21	Door Assembly
22	Ceramic Log Set

NOTE: DIAGRAMS AND ILLUSTRATIONS ARE NOT TO SCALE

PART IDENTIFICATION

3-Piece Surround Assembly

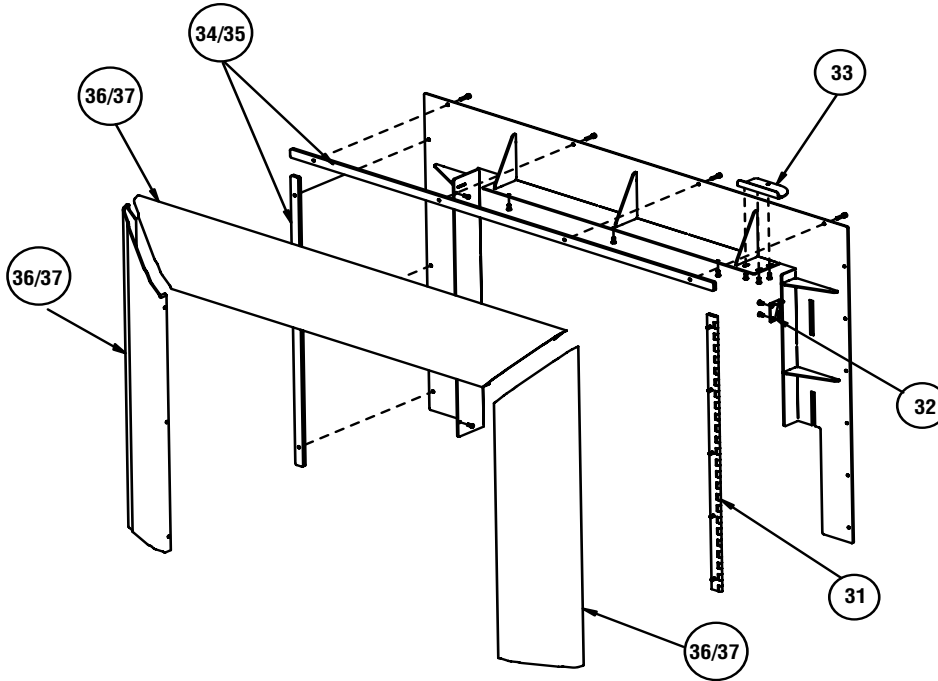

Item #	Description
31	Surround Flange Hinge
32	Ball Screw Mount
33	Ball Screw Catch
34	Surround Spacer Kit - Small
35	Surround Spacer Kit - Large
36	Extrusion Kit, 3-Piece - Small
37	Extrusion Kit, 3-Piece - Large
38	Extrusion Kit, 4-Piece - Small
39	Extrusion Kit, 4-Piece - Large

4-Piece Surround Assembly

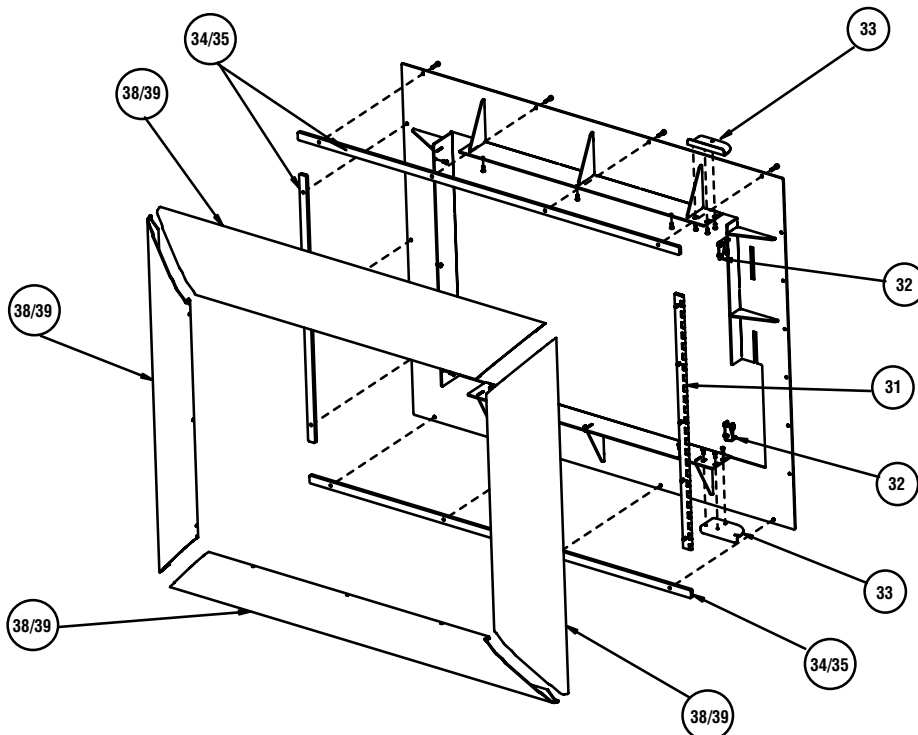

OPTIONAL ACCESSORIES

Deluxe Remote Control System

The Model RCL-T (Deluxe) Remote Control System has all of the features of the standard system along with an added easy to read LCD screen which presents access to many enhancements, including; battery power level indicator, timer, mode of operation, thermostatic display including room temperature in either metric or English units, flame indicator and clock. Fully programmable, the Model RCL-T allows for command over nearly all operational and temperature variables, using the hand held remote control transmitter.



<u>Cat. No.</u>	<u>Model</u>	<u>Description</u>
H0251	RCL-T	Remote Control System (Deluxe)

Standard Remote Control System

The Model RCL (Standard) Remote Control System, features a simple On/Off control function for the insert. This model includes a hand-held transmitter, a remote receiver with wall-mount coverplate and all hardware required to install the unit. The remote receiver can be wall or hearth mounted.



<u>Cat. No.</u>	<u>Model</u>	<u>Description</u>
H0249	RCL	Remote Control System (Standard)

Fuel Conversion Kits

Converting your Shoreline™ gas insert between natural gas (40,000-33,000 BTU's) and LP (37,500-33,000 BTU's) or vice versa can be accomplished by installing a conversion kit (valve regulator for fuel conversion and burner orifice). Only a qualified service technician should perform the conversion.

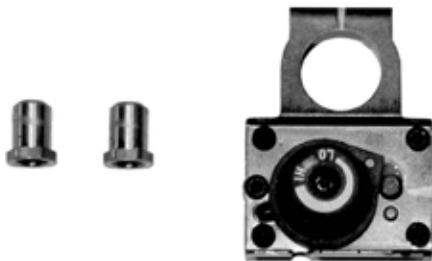

<u>Cat. No.</u>	<u>Model</u>	<u>Description</u>
75390	SHR-CK-NG to LP	Natural Gas to Propane Conversion Kit
75393	SHR-CK-LP to NG	Propane to Natural Gas Conversion Kit

Wall Thermostat

The wall thermostat kit provides temperature control for optimum comfort.



<u>Cat. No.</u>	<u>Model</u>	<u>Description</u>
H4635	DWTK	Wall Thermostat Kit, Digital

Screen Panel Kit

This screen panel kit can be installed over the glass enclosure panel to help protect from making direct contact with the hot glass surface.

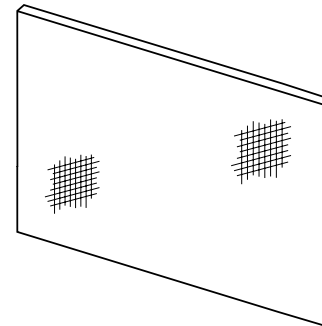

<u>Cat. No.</u>	<u>Model</u>	<u>Description</u>
75392	SHR-GS-BLK	Glass Screen Panel Kit, Black

Touch-Up Paint Kit

Repair of minor scratches and discoloration of the appliance's black painted surfaces may be accomplished with the use of this touch-up paint kit.



<u>Cat. No.</u>	<u>Model</u>	<u>Description</u>
70K99	TPK-B	Touch-Up Paint Kit, Black

OPTIONAL ACCESSORIES

Surround Kits

These surround panels install around the insert body providing an attractive finished look. *Note: See Page 32 for additional information on surround kits*

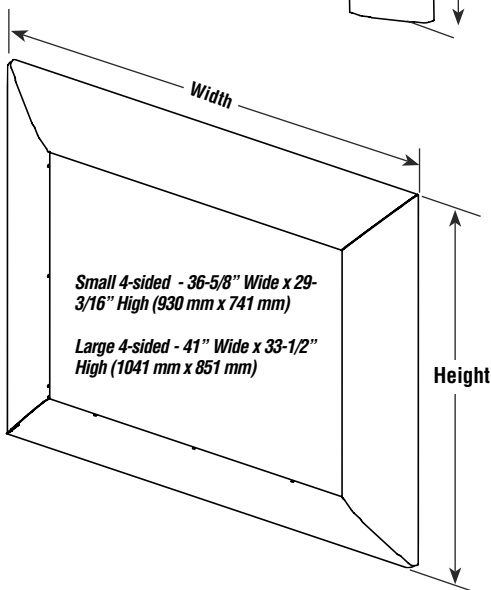
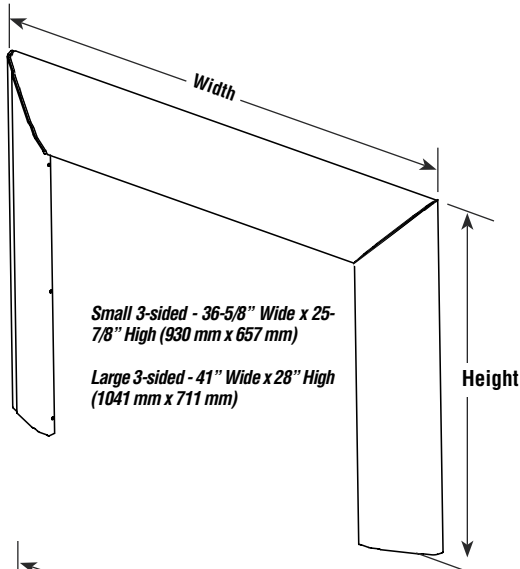

Cat. No.	Model	Description
75385	SHR-SP-4P-SM	Surround Panel Kits, 4 piece, Small
75386	SHR-SP-4P-LG	Surround Panel Kits, 4 piece, Large
75387	SHR-SP-3P-SM	Surround Panel Kits, 3 piece, Small
75388	SHR-SP-3P-LG	Surround Panel Kits, 3 piece, Large

Refractory Brick Panel Set (6 pieces)

These decorative brick panels sets are offered in 3 attractive styles. One set required.

IMPORTANT NOTE: A refractory brick panel kit is required for proper operation (sold separately). Never operate this appliance without all the refractory brick panels properly installed.

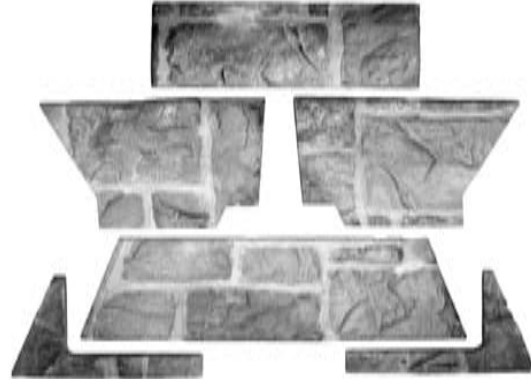

Standard Brick



Red Brick

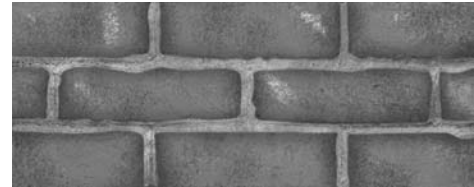

Architectural Stone



Cat. No.	Model	Description
75383	SHR-BRICK-STD	Brick Panel Set, Standard
75384	SHR-BRICK-RED	Brick Panel Set, Red
75391	SHR-BRICK-ARCHSTONE	Brick Panel Set, Archstone

OPTIONAL ACCESSORIES

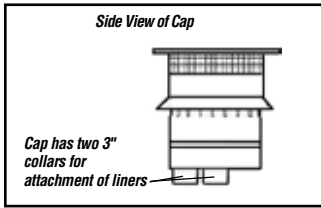
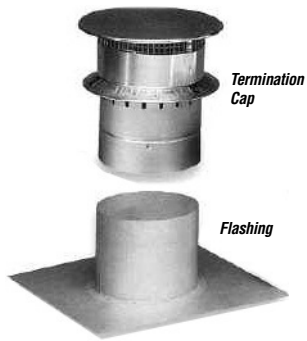

Flex Kit, DVI 3" X 35'		
Cat. No.	Model	Description
H0909	FKDVI	Flex Kit, DVI 3" X 35'

Termination Kit, DVI		
Cat. No.	Model	Description
TKDVI	TKDVI	Termination Kit, DVI

SAFETY / LISTING LABEL

MODEL SHR 40 **SERIAL NO.** SHR
MODÈLE **NO.**

Manufactured by / Fabriqué par:
LENNOX HEARTH PRODUCTS
 PO BOX 987
 AUBURN, WA., USA 98071
HEARTH PRODUCTS

Tested & Listed by: **OMNI-Test Laboratories, Inc.**
 Beaverton Oregon USA
 Report No. / Numéro de Rapport: 050-F-22-5
 FACTORY EQUIPPED FOR NATURAL GAS. IF CONTROL PANEL CONTRADICTS THIS LABEL, UNIT FUEL TYPE HAS BEEN CONVERTED. CET APPAREIL EST MUNI D'ÉQUIPEMENT POUR L'USAGE DU GAZ NATUREL. SI L'ÉTIQUETTE DU PANNEAU DES COMMANDES CONTIENT CETTE ÉTIQUETTE, C'EST QUE LE TYPE DE CARBURANT DE CET APPAREIL A ÉTÉ CONVERTI.

LISTED VENTED GAS FIREPLACE HEATER - FIREPLACE INSERT - NOT FOR USE WITH SOLID FUEL
 TESTED TO ANSI Z21.88-2005/CSA 2.33-2005 "VENTED GAS FIREPLACE HEATERS", UL307b, CSA P.4.1-02, AND CGA 2.17-M91. THIS APPLIANCE MUST BE INSTALLED IN ACCORDANCE WITH LOCAL CODES, IF ANY. IF NOT, FOLLOW ANSI NFPA 70 - Latest Edition (USA), CAN/CGA-B149-Latest Edition (CANADA). THIS APPLIANCE MUST BE INSTALLED IN ACCORDANCE WITH THE MANUFACTURER'S INSTALLATION INSTRUCTION. FOR INSTALLATION IN SOLID FUEL BURNING FIREPLACES ONLY - MASONRY OR FACTORY BUILT. THIS VENTED GAS FIREPLACE HEATER IS NOT FOR USE WITH AIR FILTERS.

THIS APPLIANCE IS ONLY FOR USE WITH THE TYPE OF GAS INDICATED ON THE RATING PLATE AND MAY BE INSTALLED IN AN AFTERMARKET, PERMANENTLY LOCATED, MANUFACTURED (MOBILE) HOME WHERE NOT PROHIBITED BY LOCAL CODES. SEE OWNER'S MANUAL FOR DETAILS. THIS APPLIANCE IS NOT CONVERTIBLE FOR USE WITH OTHER GASES UNLESS A CERTIFIED KIT IS USED.

DANGER: RISK OF ELECTRICAL SHOCK. DISCONNECT POWER BEFORE SERVICING UNIT.
 IF ELECTRICALLY CONNECTED, CONNECTIONS AND GROUNDING MUST BE IN ACCORDANCE WITH LOCAL CODES, IF ANY. IF NOT, FOLLOW THE CURRENT NATIONAL ELECTRICAL CODE ANS/NFPA 70.

RATINGS	Model SHR40		Model SHR33	
	NATURAL GAS	LP GAS	NATURAL GAS	LP GAS
MAXIMUM INPUT BTU/Hr 0-2,000 FT (0-610 M)	40,000 / 24,000	37,500 / 21,500	33,000 / 19,500	33,000 / 19,500
MANIFOLD PRESSURE (IN. WC)	3.5	10.0	3.5	10.0
MIN. INLET PRESSURE (IN. WC)	5.0	10.5	5.0	10.5
ORIFICE (DMS) 0-2,000 FT (0-610 M)	.125	#49	#36	#51

UNIT FACTORY EQUIPPED FOR 0-2000 FT/0-610 M, IN CANADA 0-4500 FT/0-1370 M
 ELECTRICAL RATING: 115 VAC, 60 HZ, LESS THAN 2 AMPS

CHIMNEY - USE 3" DIAMETER SINGLEWALL OR FLEX GAS VENT CHIMNEY OR LINER LISTED TO UL1777.
 THIS APPLIANCE MUST BE PROPERLY CONNECTED TO A VENTING SYSTEM IN ACCORDANCE WITH THE MANUFACTURER'S INSTALLATION INSTRUCTIONS.
 FOR ALTITUDES ABOVE 2,000 FT/610M (IN CANADA 4500 FT/1370M) DE-RATE THE APPLIANCE BY FOUR (4)% FOR EVERY 1,000 FT (405 M).

MINIMUM CLEARANCES TO COMBUSTIBLES

SHR40/SHR33

E = Top Facing to Bottom of Insert 35"
 F = Center of Fireplace to Side Facing or Side Wall 30"
 J = 12" Mantel to Bottom of Insert 38"
 * See owner's manual for additional mantel clearances and options

MINIMUM FIREPLACE SIZES REQUIRED

A = 36.00" Front Opening
 B = 21.50" Height
 C = 19.50" Rear Width
 D = 16.00" Fireplace Depth

HEARTH PROTECTION

G = Minimum Hearth Protection from Front of Insert
 H = Vertical Distance from Insert Bottom to Combustible Material

SHR40/33		
G	12"	0"
H	0"	8"

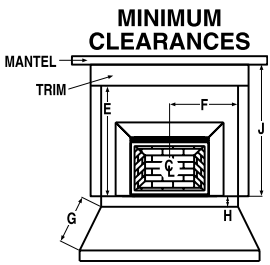

Note: Hearth protection to be min. 1" thick non-combustible or equivalent, with a k factor of .84.

CAUTION: HOT WHILE IN OPERATION. DO NOT TOUCH. SEVERE BURNS MAY RESULT. KEEP CHILDREN, CLOTHING, FURNITURE, GASOLINE AND OTHER LIQUIDS HAVING FLAMMABLE VAPORS AWAY. KEEP BURNER AND CONTROL COMPARTMENT CLEAN. SEE INSTALLATION AND OPERATING INSTRUCTIONS ACCOMPANYING APPLIANCE. FOR USE WITH GLASS DOORS CERTIFIED WITH THIS APPLIANCE ONLY. DO NOT OPERATE THE APPLIANCE WITH GLASS REMOVED, CRACKED OR BROKEN. REPLACEMENT OF THE PANEL(S) SHOULD BE DONE BY A LICENSED OR QUALIFIED PERSON.

WARNING: IMPROPER INSTALLATION, ADJUSTMENT, ALTERATION, SERVICE OR MAINTENANCE CAN CAUSE INJURY OR PROPERTY DAMAGE. REFER TO THE OWNER'S INFORMATION MANUAL PROVIDED WITH THIS APPLIANCE. FOR ASSISTANCE OR ADDITIONAL INFORMATION CONSULT A QUALIFIED INSTALLER, SERVICE AGENCY OR GAS SUPPLIER.

HOMOLOGUÉ FOYER RADIANT PRÉFABRIQUÉ AU GAZ - INSERTION DE FOYER AU GAZ - NE PAS UTILISER AVEC DU COMBUSTIBLE SOLIDE

TESTÉ SELON LA NORME ANSI Z21.88-2005/CSA 2.33-2005 «FOYER RADIANT AU GAZ», UL307b, CSA P.4.1-02, ET CGA 2.17-M91. CET APPAREIL DOIT ÊTRE INSTALLÉ CONFORMÉMENT AUX EXIGENCES DES CODES RÉGIONAUX ET DU CODE D'INSTALLATION ANSI NFPA 70-DERNIÈRE ÉDITION (ÉTATS-UNIS), OU CAN/CGA-B149-DERNIÈRE ÉDITION (CANADA). CET APPAREIL DOIT ÊTRE INSTALLÉ SELON LES DIRECTIVES D'INSTALLATION DU FABRICANT. POUR L'INSTALLATION DANS DES FOYERS À COMBUSTIBLE SOLIDE SEULEMENT - DE MAÇONNERIE OU PRÉFABRIQUÉ EN USINE. CE FOYER RADIANT AU GAZ À ÉVACUATION N'EST PAS CONÇU POUR ÊTRE UTILISÉ AVEC DES FILTRES À AIR.

CET APPAREIL DOIT ÊTRE UTILISÉ AVEC LE TYPE DE GAZ INDICÉ SUR LA PLAQUE SIGNALÉTIQUE ET PEUT ÊTRE INSTALLÉ DANS UNE MAISON PRÉUSINÉE OU DANS UNE MAISON MOBILE FIXE, LÀ OÙ LES CODES RÉGIONAUX LE PERMETTENT. VOIR LE MANUEL D'ENTRETIEN POUR PLUS DE DÉTAILS. CET APPAREIL NE PEUT PAS ÊTRE CONVERTI POUR L'USAGE AVEC D'AUTRES TYPES DE GAZ À MOINS D'UTILISER UNE TROUSSE DE CONVERSION HOMOLOGUÉE.

DANGER: RISQUE DE CHOC ÉLECTRIQUE. DÉBRANCHEZ L'APPAREIL AVANT D'EN FAIRE L'ENTRETIEN.
 SI L'APPAREIL REQUIERT UN BRANCHEMENT ÉLECTRIQUE, LES RACCORDEMENTS ET LA MISE À LA TERRE DOIVENT ÊTRE CONFORMES AUX EXIGENCES DES CODES RÉGIONAUX ET DU CODE D'INSTALLATION ANS/NFPA 70 OU CAN/CGA-B-149.

SPÉCIFICATIONS	Modèle SHR40		Modèle SHR33	
	GAZ NATUREL	GAZ PROPANE	GAZ NATUREL	GAZ PROPANE
ENTRÉE MAX/IN BTU/Hr 0-2,000 pi (0-610 M)	40000 / 24000	37500 / 21500	33000 / 19500	33000 / 19500
PRESSION À LA SORTIE (IN. WC/C.E.)	3.5	10.0	3.5	10.0
PRESSION MINIMUM D'ENTRÉE DU GAZ (IN. WC/C.E.)	5.0	10.5	5.0	10.5
ORIFICE (DMS) 0-2,000 pi (0-610 M)	.125	#49	#36	#51

L'APPAREIL PRÉUSINÉ EST MUNI D'ÉQUIPEMENT POUR 0-2000 PIEDS (0-610M), AU CANADA 0-4500 PIEDS (0-1370M).
 SPÉCIFICATIONS ÉLECTRIQUE: 115 VCA, 60 HZ, MOINS DE 2 AMPÈRES

CHÉMINÉE - UTILISER UN CONDUIT D'ÉVACUATION 3" DE DIAMÈTRE RIDIGÉ OU FLEXIBLE HOMOLOGUÉ UL 1777.
 CET APPAREIL DOIT ÊTRE RELIÉ À UN SYSTÈME D'ÉVACUATION TEL QUE SPÉCIFIÉ DANS LE MANUEL D'INSTALLATION DU FABRICANT.

EN ALTITUDE, AU-DELÀ DE 2000 PI/610 M, (AU CANADA 0-4500 PI/1370M) LA CAPACITÉ ÉNERGÉTIQUE DE L'APPAREIL DIMINUE DE QUATRE (4)% POUR CHAQUE 1000 PI (405 M).

DÉGAGEMENTS AUX COMBUSTIBLES

SHR40/SHR33

E = Dessus du foyer à partir de la base 35"
 F = Mur latéral à partir du centre du foyer 30"
 J = 12" manteau de foyer à partir de la base 38"
 * Voir le manuel d'entretien pour les informations supplémentaires reliées aux distances à respecter pour le manteau de foyer

DIMENSIONS MINIMUMS DE FOYER REQUISES

- A = 36.00" Ouverture avant
- B = 21.50" Hauteur
- C = 19.50" Largeur arrière
- D = 16.00" Profondeur du foyer

PROTECTION DU FOYER

G = Extension d'âtre min. devant le foyer
 H = Distance verticale de la base de l'appareil aux combustibles

SHR40/33		
G	12"	0"
H	0"	8"

Note: Extension d'âtre fabriqué avec 1" minimum de matériaux non-combustible ou équivalent possédant un facteur k de 0.84.

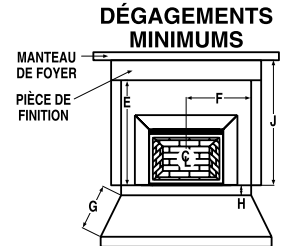

DANGER: CET APPAREIL DÉGAGE DES TEMPÉRATURES ÉLEVÉES ET DEVRAIT ÊTRE INSTALLÉ À L'ÉCART DES ENDROITS TRÈS PASSANTS ET LOIN DES MEUBLES ET RIDEAUX. SURVEILLEZ LES ENFANTS QUI SE TROUVENT DANS LA PIÈCE. GARDEZ LA ZONE AUTOUR DU FOYER EXEMPTÉ DE MATÉRIEAUX COMBUSTIBLES, D'ESSENCE ET AUTRES VAPEURS ET LIQUIDES INFLAMMABLES. MAINTENEZ LE BRÛLEUR ET LE BOITIER DES COMMANDES PROPRE EN TOUT TEMPS. VOIR LES MANUELS D'INSTALLATION ET D'ENTRETIEN QUI ACCOMPAGNENT L'APPAREIL. SEUL LE PANNEAU VITRÉ FOURNI PAR LE MANUFACTURIER PEUT ÊTRE UTILISÉ AVEC CET APPAREIL. EN AUCUN CAS, L'APPAREIL NE PEUT ÊTRE UTILISÉ SANS LA VITRE OU AVEC LA VITRE BRISÉE. LE REMPLACEMENT DE LA VITRE DOIT ÊTRE EFFECTUÉ PAR UN TECHNICIEN DE SERVICE QUALIFIÉ.

AVERTISSEMENT: UNE INSTALLATION INADÉQUATE DE MÊME QU'UN AJUSTEMENT, UNE MODIFICATION, UNE RÉPARATION OU UN ENTRETIEN INCORRECTS PEUVENT CAUSER DES BLESSURES OU DOMMAGES À LA PROPRIÉTÉ. RÉFÉREZ-VOUS AU MANUEL D'ENTRETIEN LIVRÉ AVEC CET APPAREIL. POUR DE L'ASSISTANCE, CONSULTEZ UN INSTALLATEUR QUALIFIÉ, UNE ENTREPRISE DE SERVICE OU UN FOURNISSEUR DE GAZ.

DATE OF MANUFACTURE / DATE DE FABRICATION

2007	2008	2009	2010	JAN	FEB	MAR	APR	MAY	JUN	JUL	AUG	SEP	OCT	NOV	DEC
				JANV.	FEVR.	MARS	AVR.	MAI	JUIN	JUIL.	AOÛT	SEPT.	OCT.	NOV.	DEC.
<input type="checkbox"/>	<input type="checkbox"/>	<input type="checkbox"/>	<input type="checkbox"/>	<input type="checkbox"/>	<input type="checkbox"/>	<input type="checkbox"/>	<input type="checkbox"/>	<input type="checkbox"/>	<input type="checkbox"/>	<input type="checkbox"/>	<input type="checkbox"/>	<input type="checkbox"/>	<input type="checkbox"/>	<input type="checkbox"/>	<input type="checkbox"/>

N'ENLEVEZ PAS OU NE COUVREZ PAS CETTE ÉTIQUETTE

IGN

LIGHTING INSTRUCTIONS LABEL

FOR YOUR SAFETY READ BEFORE OPERATING

WARNING: IF YOU DO NOT FOLLOW THESE INSTRUCTIONS EXACTLY, A FIRE OR EXPLOSION MAY RESULT CAUSING PROPERTY DAMAGE, INJURY OR LOSS OF LIFE.

CAUTION: HOT WHILE IN OPERATION. DO NOT TOUCH. KEEP CHILDREN, FURNITURE, GASOLINE AND OTHER LIQUIDS WITH FLAMMABLE VAPORS AWAY. NEVER OPERATE UNIT WITH GLASS DOOR OFF OR ATTEMPT TO OPEN THE DOOR WHILE HOT.

- A. This appliance is equipped with a piezo ignition device to light the pilot. When lighting the pilot, follow these instructions exactly.
- B. **BEFORE LIGHTING**, smell around the appliance area for gas. Be sure to smell next to the floor because some gas is heavier than air and will settle on the floor.

WHAT TO DO IF YOU SMELL GAS:

- DO NOT try to light the appliance.
 - DO NOT touch any electric switch; do not use any phone in the building.
 - Immediately call your gas supplier from a neighbor's phone. Follow the gas supplier's instructions.
 - If you cannot reach your gas supplier, call the fire department.
- C. Use only your hand to push in or turn the gas control knob. Never use any tool. If the knob will not push in or turn by hand, don't try to repair it, call a qualified service technician. Force or attempted repair may result in a fire or explosion.
- D. DO NOT use this appliance if any part has been under water. Immediately call a qualified service technician to inspect the appliance and to replace any part of the control system and any gas control which has been under water.

OPERATING INSTRUCTIONS

CAUTION: YOUR COUNTRY GAS APPLIANCE MUST ALWAYS BE OPERATED WITH GLASS DOOR IN PLACE.

STOP! Read the safety information above before proceeding.

1. Open the right side access door. Make sure gas supply shut-off cocks are open and ON/OFF Rocker Switch is "OFF". If equipped with a thermostat, set it to the lowest setting.
2. Turn off all electrical power to the appliance.
3. Push in Gas Control Knob slightly and turn clockwise to "OFF".
NOTE: Knob cannot be turned from "PILOT" to "OFF" unless Knob is pushed in slightly. Do not force.
4. Wait five (5) minutes to clear out any gas. If you smell gas, STOP! Follow "B" above. If you don't smell gas continue.
5. Locate the pilot by looking at the rear center of the burner, behind the large center log. Blue flame will be seen when the pilot is lit.
6. Turn the gas control knob counterclockwise to the "PILOT" position.
7. Push the knob all the way in and hold in that position. Immediately light the pilot by pressing the ignitor button several times until pilot is lit. Continue to hold the knob in for about 30 seconds after the pilot is lit. Release knob and it will pop back out. Pilot should remain lit. If it goes out, repeat steps 4-8 holding knob in an additional 15 seconds after pilot is lit.
- If knob does not pop out when released, stop and immediately call your service technician or your gas supplier.
- If the pilot will not stay lit after several tries, turn the gas control knob to "OFF" and call your service technician or your gas supplier.
8. After pilot is lit, turn gas control counterclockwise to "ON". Knob can only be turned "ON" if the knob has popped out.
9. To turn burner on, turn "ON/OFF" rocker switch to "ON" or set the thermostat to the desired temperature above room temperature.
10. Adjust the flame height (and heat output) by turning the flame height knob clockwise for reduced flame and counterclockwise for full flame.
11. Set the blower to the desired air flow after it turns on when the appliance reaches operating temperature.

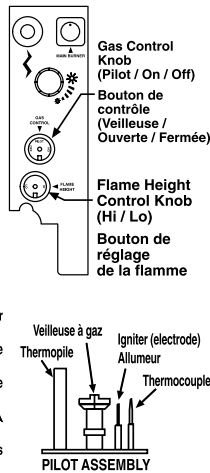

TO TURN OFF GAS TO APPLIANCE

1. Turn off the "ON/OFF" rocker switch and/or thermostat (if installed).
2. Turn off electric power to the appliance if service is to be performed.
3. Turn gas control knob clockwise to "OFF". Do not force.

This appliance needs fresh air for safe operation and must be installed so there are provisions for adequate combustion and ventilation air. See Installation and Operation Manual accompanying appliance.

WARNING: Improper installation, adjustment, alteration, service or maintenance can cause injury or property damage. For assistance or additional information, consult a qualified installer, service agency or your gas supplier.

Operation of this appliance when not connected to a properly installed and maintained venting system can result in carbon monoxide (CO) poisoning and possible death.

SHUTDOWN PROCEDURE

1. To turn off the burner, switch the rocker switch to "OFF" or adjust the thermostat to a setting below room temperature (if installed). The pilot will remain lit for future burner ignition.
- For complete shutdown: See "TO TURN OFF GAS TO APPLIANCE" above.

POUR VOTRE SÉCURITÉ, LIRE AVANT L'ALLUMAGE

AVERTISSEMENT: SI VOUS NE RESPECTEZ PAS RIGOREUSEMENT LES INSTRUCTIONS CI-DESSOUS, VOUS POURRIEZ ENCOURIR UN RISQUE D'INCENDIE ET/OU D'EXPLOSION QUI POURRAIENT CAUSER DES DOMMAGES MATÉRIELS ET CORPORELS POUVANT ENTRAÎNER LA MORT.

DANGER: CET APPAREIL DÉGAGE DES TEMPÉRATURES ÉLEVÉES ET DEVIENDRAIT ÊTRE INSTALLÉ À L'ÉCART DES ENDROITS TRÈS PASSANTS ET LOIN DES MEUBLES ET RIDEAUX. GARDEZ LA ZONE AUTOUR DU FOYER EXEMPTÉ DE MATÉRIELS COMBUSTIBLES, D'ESSENCE ET AUTRES VAPEURS ET LIQUIDES INFLAMMABLES.

- A. Cet appareil utilise un système d'allumage par étincelle (allumeur Piézo-électrique) pour allumer la veilleuse. Assurez-vous de suivre rigoureusement les instructions d'allumage de la veilleuse.
- B. **AVANT D'ALLUMER L'APPAREIL**, assurez-vous qu'il n'y a pas d'odeur de gaz près de l'appareil ni près du sol car certains gaz plus lourds que l'air auraient tendance à s'y accumuler en cas de fuite.

QUE FAIRE SI VOUS SENTEZ UNE ODEUR DE GAZ:

- N'ALLUMEZ aucun appareil.
 - Ne touchez aucune prise électrique; N'utilisez aucun téléphone dans votre édifice.
 - Sortez de la maison. À partir d'un autre endroit, appelez immédiatement votre fournisseur de gaz et suivez les directives.
 - S'il est impossible de joindre le distributeur du gaz, appelez les pompiers.
- C. N'utilisez aucun outil pour tourner ou pousser le dispositif de contrôle du gaz. Si vous ne pouvez le faire manuellement, n'essayez pas de réparer l'appareil. Appelez un technicien de service qualifié. Si vous tentez de forcer ou réparer le dispositif de contrôle du gaz vous pourriez encourir un risque d'incendie et/ou d'explosion.
- D. N'utilisez pas cet appareil si une de ses composantes a été émergée dans l'eau. Appelez immédiatement un technicien de service qualifié et reconnu afin qu'il inspecte et remplace au besoin toutes pièces du système qui auraient été en contact avec l'eau.

ALLUMAGE

DANGER: VOTRE APPAREIL AU GAZ LENNOX DOIT ÊTRE OPÉRÉ AVEC DES PORTES DE VERRE.

ATTENTION! Lisez les consignes de sécurité ci-dessous avant d'opérer votre appareil.

1. Ouvrez la porte d'accès à la droite de l'appareil. Assurez-vous que l'alimentation en gaz est à la position Fermée "OFF". Si l'appareil est équipé d'un thermostat, placez-le à la température la plus basse.
2. Couper le courant électrique qui alimente l'appareil.
3. Enfoncez légèrement le bouton de contrôle du gaz et tournez-le dans le sens des aiguilles d'une montre à la position "OFF".
NOTE: Le bouton de contrôle du gaz ne peut être tourné de la position "PILOT" à "OFF" sans qu'une légère pression ne soit appliquée.
4. Attendez au moins 5 minutes pour que le gaz qui se trouve dans la chambre de combustion puisse s'échapper. Si vous sentez une odeur de gaz ARRÊTEZ-VOUS à la section B ci-dessus. Si vous ne sentez pas d'odeur de gaz, allez à la prochaine étape.
5. Repérez la veilleuse située au centre de la chambre de combustion, sous la bûche céramique arrière. Une flamme bleue est visible lorsque la veilleuse est allumée.
6. Tournez le bouton de contrôle de gaz dans le sens inverse des aiguilles d'une montre pour le placer sur "PILOT".
7. Cet appareil de chauffage est équipé d'un système d'allumage par étincelle (allumeur Piézo-électrique), devant être utilisé pour l'allumage de la veilleuse. Poussez complètement le bouton de contrôle du gaz et le maintenir dans cette position. Appuyez immédiatement sur le bouton (allumeur Piézo-électrique) situé à gauche du robinet de contrôle du gaz. L'étincelle produite par l'allumeur Piézo-électrique doit allumer la veilleuse. Continuez à maintenir le bouton de contrôle dans cette position pendant environ 30 secondes après l'allumage de la veilleuse. Relâchez le bouton de contrôle du gaz qui reviendra à la position initiale. La veilleuse doit rester allumée. Répétez les étapes 4 à 8 pendant 15 secondes supplémentaires si la veilleuse s'éteint.
- Si le bouton de contrôle du gaz ne revient pas à la position initiale une fois relâché, appelez immédiatement un technicien qualifié ou votre distributeur de gaz.
- Si la veilleuse ne reste pas allumée après plusieurs essais, tournez le bouton de contrôle du gaz à la position "OFF" et appelez immédiatement un technicien qualifié ou votre distributeur de gaz.
8. Lorsque la veilleuse est allumée, tournez le bouton de contrôle du gaz dans le sens inverse des aiguilles d'une montre pour le placer à la position "ON". Le bouton de contrôle peut-être tourné à la position "ON" seulement si il n'est plus enfoncé.
9. Pour allumer le brûleur, mettre l'interrupteur à la position "ON" ou ajustez le thermostat à la température souhaitée.
10. Ajustez la flamme et la température souhaitée en tournant le bouton de réglage de la flamme dans le sens des aiguilles d'une montre pour l'abaisser et dans le sens contraire pour l'augmenter.
11. Ajustez le ventilateur au volume désiré lorsque l'appareil aura atteint la température de fonctionnement.

POUR COUPER L'ALIMENTATION EN GAZ DE L'APPAREIL

1. Fermez l'interrupteur et/ou le thermostat «MARCHE/ARRÊT».
2. Coupez l'alimentation électrique de l'appareil si vous prévoyez en faire le service.
3. Tournez le bouton de commande du gaz dans le sens des aiguilles d'une montre à "OFF". Ne le forcez pas.

Cet appareil a besoin d'air frais pour opérer sécuritairement et doit être installé pour qu'il y ait un apport en air suffisant. Référez-vous aux manuels d'entretien et d'installation fournis avec l'appareil.

AVERTISSEMENT: Une installation inadéquate, un mauvais ajustement, une altération ou toutes autres modifications inappropriés pourraient entraîner des blessures physiques et/ou des dommages matériels. Référez-vous au guide d'utilisation fourni avec ce foyer. Pour assistance ou information supplémentaires contactez un installateur qualifié, un agent de service ou un fournisseur de gaz.

Si vous opérez cet appareil sans qu'il ne soit correctement raccordé à un conduit d'évacuation, vous pourriez risquer d'être empoisonné au monoxyde de carbone (CO) ce qui pourrait entraîner des conséquences graves ou la mort.

PROCÉDURE D'ARRÊT

1. Pour arrêter le brûleur, mettre l'interrupteur à la position "OFF" ou ajustez le thermostat à une température en dessous de la température ambiante. La veilleuse restera allumée pour permettre un allumage ultérieur.
- Pour un arrêt complet: Consultez la procédure ci-dessus «POUR COUPER L'ALIMENTATION EN GAZ DE L'APPAREIL».

WARRANTY

Your gas appliance is covered by a limited warranty (see warranty certificate provided with appliance). Please read the warranty to be familiar with its coverage.

Retain this manual. File it with your other documents for future reference.

PRODUCT REFERENCE INFORMATION

We recommend that you record the following important information about your fireplace. Please contact your Lennox dealer for any questions or concerns. For the number of your nearest Lennox dealer, please call 1-800-9-LENNOX.

REPLACEMENT PARTS

See **Page 27** for a complete replacement parts list. Use only parts supplied from the manufacturer.

Normally, all parts should be ordered through your Lennox distributor or dealer. Parts will be shipped at prevailing prices at time of order.

When ordering repair parts, always give the following information:

1. The model number of the appliance.
2. The serial number of the appliance.
3. The part number.
4. The description of the part.
5. The quantity required.
6. The installation date of the appliance.

If you encounter any problems or have any questions concerning the installation or application of this system, please contact your dealer.

LENNOX HEARTH PRODUCTS

1110 West Taft
Orange, CA 92865
visit us at www.Lennox.com

Your Fireplace Insert's Model Number _____
Your Fireplace Insert's Serial Number _____
The Date On Which Your Fireplace Insert Was Installed _____
The Type of Gas Your Fireplace Insert Uses _____
Your Dealer's Name _____
Fuel Type (Check one) Natural Gas Propane Gas (LP)

NATIONAL
FIREPLACE
INSTITUTE



CERTIFIED
www.nficertified.org

We recommend that our gas hearth products be installed and serviced by professionals who are certified in the U.S. by the National Fireplace Institute® (NFI) as NFI Gas Specialists.

NATIONAL
FIREPLACE
INSTITUTE



CERTIFIED
www.nficertified.org

Nous recommandons que nos foyers au gaz soient installés et que l'entretien soit effectué par des professionnels certifiés par le National Fireplace Institute® (NFI). (Etats-Unis seulement)

Lennox reserves the right to make changes at any time, without notice, in design, materials, specifications, prices and also to discontinue colors, styles and products. Consult your local distributor for fireplace code information.

LENNOXTM

HEARTH PRODUCTS

1110 West Taft Avenue • Orange, CA 92865