



HEARTH PRODUCTS

P/N 506023-09 Rev. C 06/2011

This manual is one of a set of two supporting this product. Refer to P/N 506025-02 for Care and Operation Instructions.

Ce manuel est disponible en français, simplement en faire la demande. Numéro de la pièce 506223-29.

INSTALLATION INSTRUCTIONS

Montebello® Power Vent
Direct-Vent Gas Fireplaces



MODELS

ELECTRONIC:

LSM40EN-PV

LSM45EN-PV

Tested & Listed By



Portland Oregon USA

OMNI-Test Laboratories, Inc.

OTL Report No. 116-F-22-5

INSTALLER: Leave this manual with the appliance.
CONSUMER: Retain this manual for future reference.
INSTALLATEUR : Laissez cette notice avec l'appareil.
CONSOMMATEUR : Conservez cette notice pour consultation ultérieure.

This appliance may be installed in an aftermarket permanently located, manufactured home (USA only) or mobile home, where not prohibited by local codes. This appliance is only for use with the type of gas indicated on the rating plate. This appliance is not convertible for use with other gases unless a certified kit is used.

! WARNING / AVERTISSEMENT / AVISO

- HOT GLASS WILL CAUSE BURNS.
- DO NOT TOUCH GLASS UNTIL COOLED.
- NEVER ALLOW CHILDREN TO TOUCH GLASS.



- UNE SURFACE VITRÉE CHAUDE PEUT CAUSER DES BRÛLURES.
- LAISSER REFROIDIR LA SURFACE VITRÉE AVANT D'Y TOUCHER.
- NE PERMETTEZ JAMAIS À UN ENFANT DE TOUCHER LA SURFACE VITRÉE.

- EL VIDRIO CALIENTE CAUSARÁ QUEMADURAS.
- USTED DEBE NUNCA TOCAR EL VIDRIO CALIENTE.
- LOS NIÑOS DEBEN NUNCA TOCAR EL VIDRIO.

WARNING: If the information in these instructions is not followed exactly, a fire or explosion may result, causing property damage, personal injury, or death.

- Do not store or use gasoline or other flammable vapors and liquids in the vicinity of this or any other appliance.
- **WHAT TO DO IF YOU SMELL GAS:**
 - Do not try to light any appliance.
 - Do not touch any electrical switch; do not use any phone in your building.
 - Immediately call your gas supplier from a neighbor's phone. Follow the gas supplier's instructions.
 - If you cannot reach your gas supplier, call the fire department.
- Installation and service must be performed by a qualified installer, service agency or the gas supplier.

AVERTISSEMENT : Assurez-vous de bien suivre les instructions données dans cette notice pour réduire au minimum le risque d'incendie ou d'explosion ou pour éviter tout dommage matériel, toute blessure ou la mort.

- Ne pas entreposer ni utiliser d'essence ni d'autres vapeurs ou liquides inflammables dans le voisinage de cet appareil ou de tout autre appareil.
- **QUE FAIRE SI VOUS SENTEZ UNE ODEUR DE GAZ :**
 - Ne pas tenter d'allumer d'appareil.
 - Ne touchez à aucun interrupteur. Ne pas vous servir des téléphones se trouvant dans le bâtiment où vous trouvez.
 - Appelez immédiatement votre fournisseur de gaz depuis un voisin. Suivez les instructions du fournisseur.
 - Si vous ne pouvez rejoindre le fournisseur de gaz, appelez le service des incendies.
- L'installation et l'entretien doivent être assurés par un installateur ou un service d'entretien qualifié ou par le fournisseur de gaz.

TABLE OF CONTENTS

Packaging	Page 2
Introduction	Page 2
General Information	Page 2
Massachusetts and New York Requirements.....	Page 4
Cold Climate Insulation	Page 5
Manufactured Home Requirements ..	Page 5
Location	Page 5
Vent Termination Clearances	Page 6
Minimum Clearances to Combustibles	Page 8
Detailed Installation Steps.....	Page 9
Typical Installation Sequence	Page 9
Step 1. Framing.....	Page 9
Fireplace and Framing Specifications	Page 10
Step 2. Routing Gas Line	Page 11
Proper Sizing of Gas Line.....	Page 11
Step 3. Install the Vent System	Page 12
General Vent Information	Page 12
Power Vent Components.....	Page 12
Vent Section Length Chart	Page 13
Vertical (Offset) Installation.....	Page 13
Vent Instructions A through G.....	Page 14
Vent Figures	Page 15
Horizontal Termination System	Page 16
Installing Power Vent Termination	Page 16
Step 4. Field Wiring.....	Page 18
Step 5. Removing Glass Door	
Frame Assembly	Page 20
Step 6. Connecting Gas Line	Page 21
Step 7. Install Firebox Liner	Page 21
Step 8. Verifying Appliance	
Operation	Page 21
Step 9. Installing Logs	Page 22
Step 10. Installing Glass Door	Page 24
Step 11. Burner Adjustments	Page 24
Finishing Requirements	Page 26
Step 12. Attaching Safety-in-	
Operation Warnings.....	Page 27
Installation Accessories	Page 28
Gas Conversion Kits	Page 29

Please read and understand these instructions before beginning your installation.



We recommend that our gas hearth products be installed and serviced by professionals who are certified in the U.S. by the National Fireplace Institute® (NFI) as NFI Gas Specialists.

PACKAGING

The assembled vented gas fireplace is packaged with:

BOX 1 - Fireplace:

- Envelope (in firebox) containing *Care and Operation Instructions, Installation Instructions*, safety-in-operation warning labels, and warranty.
- Bag of glowing embers and volcanic stone
- Pull screen
- Door modesty shield
- Adaptor with probe assembly

BOX 2 - Power Vent Components:

- (1) power vent termination
- (1) termination adaptor
- (1) horizontal firestop assembly
- (1) vacuum hose
- (1) 11/32" hose clamp
- (1) strain relief
- (1) bushing
- (4) insulated 1/4" male terminals
- (2) #10 ring terminals

REQUIRED (order separately):

- One of the following brick liner kits:
 - a. Brick Liner Kit, Rustic
 - b. Brick Liner Kit, Herringbone
 - c. Brick Liner Kit, Old Cottage
 - d. Brick Liner Kit, Black.
 - e. Brick Liner Kit, Red Rustic
 - f. Brick Liner Kit, Red Herringbone
- One of the following log sets:
 - a. Birch Log set
 - b. Oak Log set

INTRODUCTION

These **Electronic** appliances are designed to operate on natural gas or propane and have an electronic intermittent pilot ignition system. External 120 Volt AC electrical power is required to operate these units.

These vented gas fireplaces are sealed combustion gas fireplaces designed for residential applications.

Use Only These Approved Vent Components

- These fireplaces are designed, tested and listed for operation and installation with, the following (4-1/2" inner and 7-1/2" outer) vent components only:

- **Secure Vent™** Direct-Vent System Components manufactured by Security Chimneys International.

These approved vent system components are labeled for identification. Do NOT use any other manufacturer's vent components with these appliances.

GENERAL INFORMATION

WARNING

Young children should be carefully supervised when they are in the same room as the appliance. Toddlers, young children and others may be susceptible to accidental contact burns. A physical barrier is recommended if there are at risk individuals in the house. To restrict access to a fireplace or stove, install an adjustable safety gate to keep toddlers, young children and other at risk individuals out of the room and away from hot surfaces.

AVERTISSEMENT

Les jeunes enfants devraient être surveillés étroitement lorsqu'ils se trouvent dans la même pièce que l'appareil. Les tout petits, les jeunes enfants ou les adultes peuvent subir des brûlures s'ils viennent en contact avec la surface chaude. Il est recommandé d'installer une barrière physique si des personnes à risques habitent la maison. Pour empêcher l'accès à un foyer ou à un poêle, installez une barrière de sécurité; cette mesure empêchera les tout petits, les jeunes enfants et toute autre personne à risque d'avoir accès à la pièce et aux surfaces chaudes.

Children and adults should be alerted to the hazards of high surface temperature and should stay away to avoid burns or clothing ignition.

Les enfants et les adultes devraient être informés des dangers que posent les températures de surface élevées et se tenir à distance afin d'éviter des brûlures ou que leurs vêtements ne s'enflamment.

DO NOT ATTEMPT TO ALTER OR MODIFY THE CONSTRUCTION OF THE APPLIANCE OR ITS COMPONENTS. ANY MODIFICATION OR ALTERATION MAY VOID THE WARRANTY, CERTIFICATION AND LISTINGS OF THIS UNIT.

⚠ WARNING

Improper installation, adjustment, alteration, service or maintenance can cause injury or property damage. Refer to this manual. For assistance or additional information consult a qualified installer, service agency or the gas supplier.

⚠ WARNING

Failure to comply with these installation instructions will result in an improperly installed and operating appliance, voiding its warranty. Any change to this appliance and/or its operating controls is dangerous.

⚠ WARNING

Clothing or other flammable material should not be placed on or near the appliance.

⚠ AVERTISSEMENT

On ne devrait pas placer de vêtements ni d'autres matières inflammables sur l'appareil ni à proximité.

⚠ WARNING

Any safety screen or guard removed for servicing the appliance must be replaced prior to operating the appliance.

⚠ AVERTISSEMENT

Tout écran ou protecteur retiré pour permettre l'entretien de l'appareil doit être remis en place avant de mettre l'appareil en marche.

⚠ WARNING

Improper installation or use of this appliance can cause serious injury or death from fire, burns, explosion or carbon monoxide poisoning.

Note: Installation and repair should be done by a qualified service person. The appliance should be inspected before use and at least annually by a professional service person. More frequent cleaning may be required due to excessive lint from carpeting, bedding material, etcetera. It is imperative that control compartments, burners and circulating air passageways of the appliance be kept clean.

Remarque : L'installation et la réparation devrait être confiées à un technicien qualifié. L'appareil devrait faire l'objet d'une inspection par un technicien professionnel avant d'être utilisé et au moins une fois l'an par la suite. Des nettoyages plus fréquents peuvent être nécessaires si les tapis, la literie, et cetera produisent une quantité importante de poussière. Il est essentiel que les compartiments abritant les commandes, les brûleurs et les conduits de circulation d'air de l'appareil soient tenus propres.

Do not use these appliances if any part has been under water. Immediately call a qualified, professional service technician to inspect the appliance and to replace any parts of the control system and any gas control which have been under water.

Ne pas utiliser cet appareil s'il a été plongé, même partiellement, dans l'eau. Appeler un technicien qualifié pour inspecter l'appareil et remplacer toute partie du système de commande et toute commande qui a été plongée dans l'eau.

Only trim kit(s) supplied by the manufacturer shall be used in the installation of this appliance.

Seules les trousse de garniture fournies par le fabricant doivent être utilisées pour l'installation de cet appareil.

These appliances comply with National Safety Standards and are tested and listed by OMNI-Test Laboratories, Inc. (Report No. 116-F-22-5) to ANSI Z21.50b in the USA, as vented gas fireplaces.

These electronic appliances are listed by OMNI-Test Laboratories for installation in bedrooms and mobile homes.

Misc. Codes / Standards -

The Installation must conform to local codes. In the absence of local codes, installation must comply with the current *National Fuel Gas Code, ANSI Z223.1.*

The appliance, when installed, must be electrically grounded in accordance with local codes or, in the absence of local codes, with the *National Electrical Code, ANSI/NFPA 70 - latest edition.*

Provide adequate clearances around air openings and adequate accessibility clearance for service and proper operation. Never obstruct the front openings of the appliance.

These appliances are designed to operate on natural or propane gas only. The use of other fuels or combination of fuels will degrade the performance of this system and may be dangerous.

These electronic appliances are manually controlled and feature an electronic intermittent pilot ignition system. External electrical power is required to operate these units.

These electronic models come standard with a manually-modulated gas valve; flame appearance and heat output can be controlled at the gas valve. The BTU Input for these appliances is shown in **Table 1.**

Input (BTU/HR) - All Models	
Model No.	Input (BTU/Hr)
Natural Gas	
LSM40EN-PV	32,500 to 42,000
LSM45EN-PV	32,500 to 42,000
Propane Gas (if field converted)	
LSM40EN-PV field-converted to propane	30,000 to 40,500
LSM45EN-PV field-converted to propane	30,000 to 40,500

Table 1

Gas Pressure - All Models

Tables 2 and 3 show the appliances' inlet and manifold gas pressure requirements:

Inlet Gas Supply Pressure (all models)		
Fuel #	Minimum	Maximum
Natural Gas	5.5" WC (1.37 kPa)	10.5" WC (2.61 kPa)
Propane	11.0" WC (2.74 kPa)	13.0" WC (3.23 kPa)

Table 2

Manifold Gas Supply Pressure (all models)		
Fuel #	Low	High
Natural Gas	(Lo) 2.2" WC (.55 kPa)	(Hi) 3.5" WC (.87 kPa)
Propane	(Lo) 6.3" WC (1.57 kPa)	(Hi) 10.0" WC (2.49 kPa)

Table 3

Test gauge connections are provided on the front of the gas control valve (identified IN for the inlet and OUT for the manifold side). Refer to **Figure 1**.

Propane tanks are at pressures that will cause damage to valve components. Verify that the tanks have step down regulators to reduce the pressure to safe levels.

These appliances must be isolated from the gas supply piping system (by closing their individual manual shut-off valve) during any pressure testing of the gas supply piping system at test pressures equal to or **less than** 1/2 psig (3.5 kPa).

These appliances and their individual shut-off valves must be disconnected from the gas supply piping system during any pressure testing of that system at pressures **greater than** 1/2 psig (3.5 kPa).

These appliances must not be connected to a chimney or flue serving a separate solid fuel burning appliance.

PURGE CYCLE

This is a power vented fireplace that requires household electrical power to operate. It will not operate during a power failure. When the fireplace is turned off, the exhaust blower will continue to operate for approximately one to two minutes after shutdown to expel the exhaust gases from the venting system.

Orifice Sizes - Sea Level To High Altitude (All Models)

These appliances are tested and approved for installation at elevations of 0-2000 feet (0-610 meters) above sea level, using the standard burner orifice sizes (marked with an "*" in **Table 4**). For elevations above 2000 feet, contact your gas supplier or qualified service technician.

Deration - At higher elevations, the amount of BTU fuel value delivered must be reduced by either:

- Using gas that has been derated by the gas company.
- Changing the burner orifice to a smaller size as regulated by the local authorities having jurisdiction and by the (USA) National Fuel Gas Code NFPA 54/ANSI Z223.1 - latest edition or, in Canada, the CAN/CSA-B149.1 codes - latest edition.

Install the appliance according to the regulations of the local authorities having jurisdiction and, in the USA, the National Fuel Gas Code NFPA 54 / ANSI Z223.1 - latest edition.

NOTE: Flame appearance will diminish 4% per thousand feet.

Burner Orifice Size Elevation 0-2000 ft. (0-610m)		
Model	Natural Gas	Propane Gas
LSM40-PV	.125" (1/8") * H7924 •	.073" (#49) H7936 •
LSM45-PV	.125" (1/8") * H7924 •	.073" (#49) H7936 •

Table 4

* Standard size installed at factory
• Part /Cat. Number

Gas Valve Diagrams

See **Figure 1** for gas valve diagram.

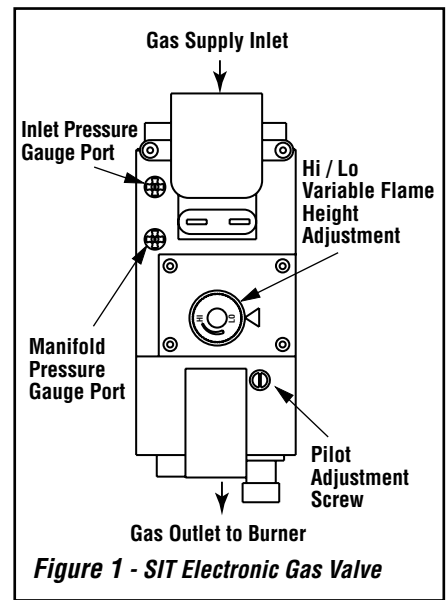

Figure 1 - SIT Electronic Gas Valve

REQUIREMENTS FOR THE COMMONWEALTH OF MASSACHUSETTS

These fireplaces are approved for installation in the US state of Massachusetts if the following additional requirements are met:

- Install this appliance in accordance with Massachusetts Rules and Regulations 248 C.M.R.
- Installation and repair must be done by a plumber or gas fitter licensed in the Commonwealth of Massachusetts.
- The flexible gas line connector used shall not exceed 36 inches (92 centimeters) in length.
- The individual manual shut-off must be a T-handle type valve.

Massachusetts Horizontal Vent Requirements

In the Commonwealth of Massachusetts, horizontal terminations installed less than seven (7) feet above the finished grade must comply with the following additional requirements:

- A hard wired carbon monoxide detector with an alarm and battery back-up must be installed on the floor level where the gas fireplace is installed. The carbon monoxide detector must comply with NFPA 720, be ANSI/UL 2034 listed and be ISA certified.
- A metal or plastic identification plate must be permanently mounted to the exterior of the building at a minimum height of eight (8) feet above grade and be directly in line with the horizontal termination. The sign must read, in print size no less than one-half (1/2) inch in size, GAS VENT DIRECTLY BELOW. KEEP CLEAR OF ALL OBSTRUCTIONS.

NEW YORK CITY, NEW YORK (MEA)

Installation of these fireplaces are approved for installation in New York City in the US state of New York.

COLD CLIMATE INSULATION

For cold climate installations, seal all cracks around your appliance with noncombustible material and wherever cold air could enter the room. It is especially important to insulate outside chase cavity between studs and under floor on which appliance rests, if floor is above ground level. Gas line holes and other openings should be caulked or stuffed with unfaced fiberglass insulation.

If the fireplace is being installed on a cement slab in cold climates, a sheet of plywood or other raised platform can be placed underneath to prevent cold transfer to the fireplace and into the room. It also helps to sheetrock inside surfaces and tape for maximum air tightness and caulk firestops.

MANUFACTURED HOME REQUIREMENTS

This appliance may be installed in an aftermarket permanently located, manufactured home and must be installed in accordance with the manufacturer's instructions and the Manufactured Home Construction and Safety Standard, Title 24 CFR, Part 3280, in the United States.

Cet appareil peut être installé comme du matériel d'origine dans une maison préfabriquée (É.U. seulement) ou mobile et doit être installé selon les instructions du fabricant et conformément à la norme Manufactured Home Constructions and Safety, Title 24 CFR, Part 3200 aux Unis.

This appliance is only for use with the type of gas indicated on the rating plate. This appliance is not convertible for use with other gases, unless a certified kit is used.

Cet appareil doit être utilisé uniquement avec le type de gaz indiqué sur la plaque signalétique. Cet appareil ne peut être converti à d'autres gaz, sauf si une trousse de conversion est utilisée.

CAUTION: Ensure that the cross members are not cut or weakened during installation. The structural integrity of the manufactured home floor, wall, and ceiling / roof must be maintained.

CAUTION: This appliance must be grounded to the chassis of the manufactured home in accordance with local codes or in the absence of local codes, with the National Electrical Code ANSI / NFPA 70 - latest edition.

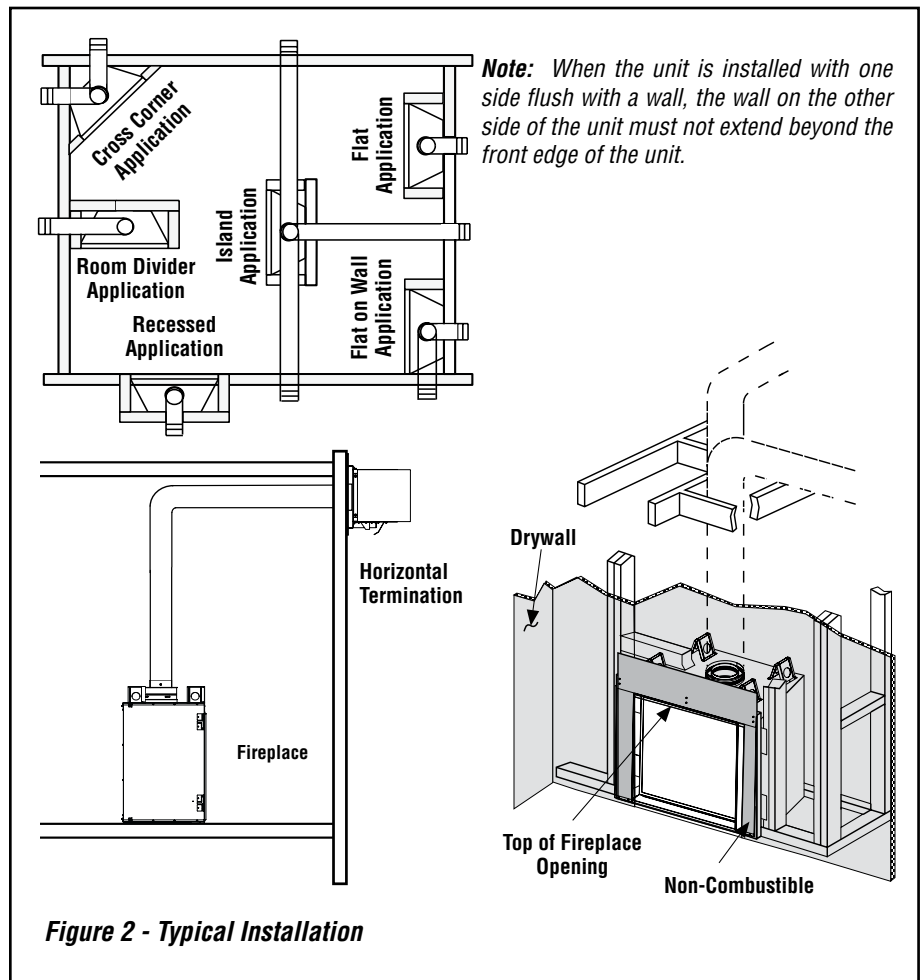

Note: When the unit is installed with one side flush with a wall, the wall on the other side of the unit must not extend beyond the front edge of the unit.

Figure 2 - Typical Installation

LOCATION

In selecting the location, the aesthetic and functional use of the appliance are primary concerns. However, vent system routing to the exterior and access to the fuel supply are also important.

Due to high temperatures, the appliance should be located out of traffic and away from furniture and draperies (Figure 2).

En raison des températures élevées, l'appareil devrait être installé dans un endroit où il y a peu de circulation et loin du mobilier et des tentures (Figure 2).

The location should also be free of electrical, plumbing or other heating/air conditioning ducting.

Be aware that this is a heat producing appliance. Objects placed above the unit are exposed to elevated temperatures.

Do not insulate the space between the appliance and the area above it.

The appliance should be mounted on a fully supported base extending the full width and depth of the unit. The appliance may be located on or near conventional construction materials. However, if installed on combustible materials, such as carpeting, vinyl tile, etc., a metal or wood barrier covering the entire bottom surface must be used.

VENT TERMINATION CLEARANCES

These instructions should be used as a guideline and do not supersede local codes in any way. Install venting according to local codes, these instructions, the current National Fuel Gas Code (ANSI-Z223.1) in the USA.

Horizontal Vent Termination Clearances

The horizontal vent termination must have a minimum of 3" (76 mm) clearance to any overhead combustible projection of 2-1/2" (64 mm) or less (see **Figure 3**). For projections exceeding 2-1/2" (64 mm), see **Figure 4**. For additional vent location restrictions refer to **Figure 4 on Page 7**.

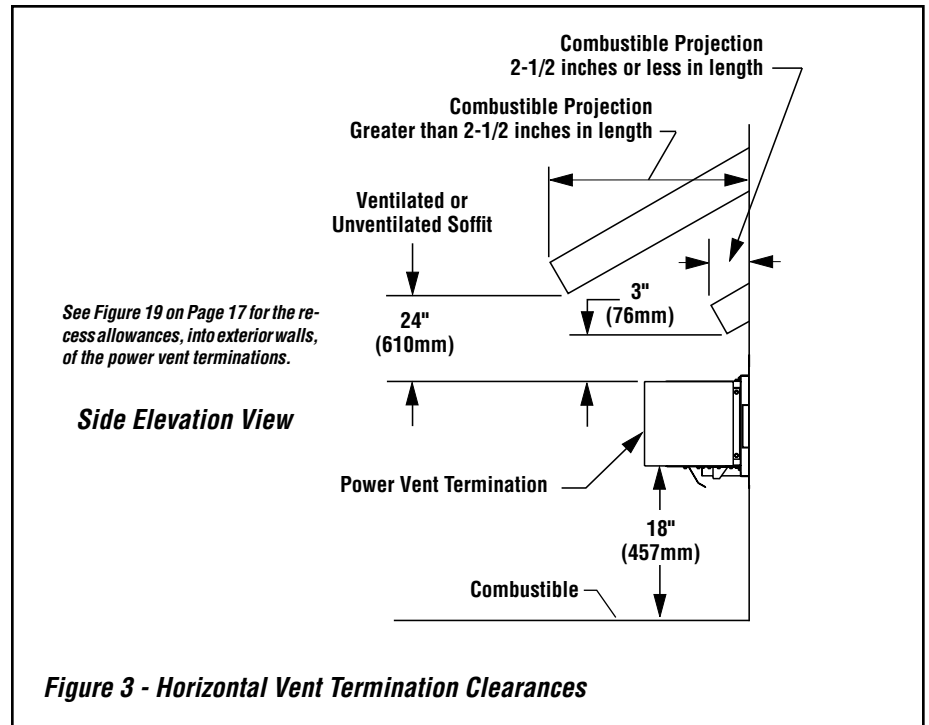

EXTERIOR HORIZONTAL VENT TERMINATION CLEARANCE REQUIREMENTS

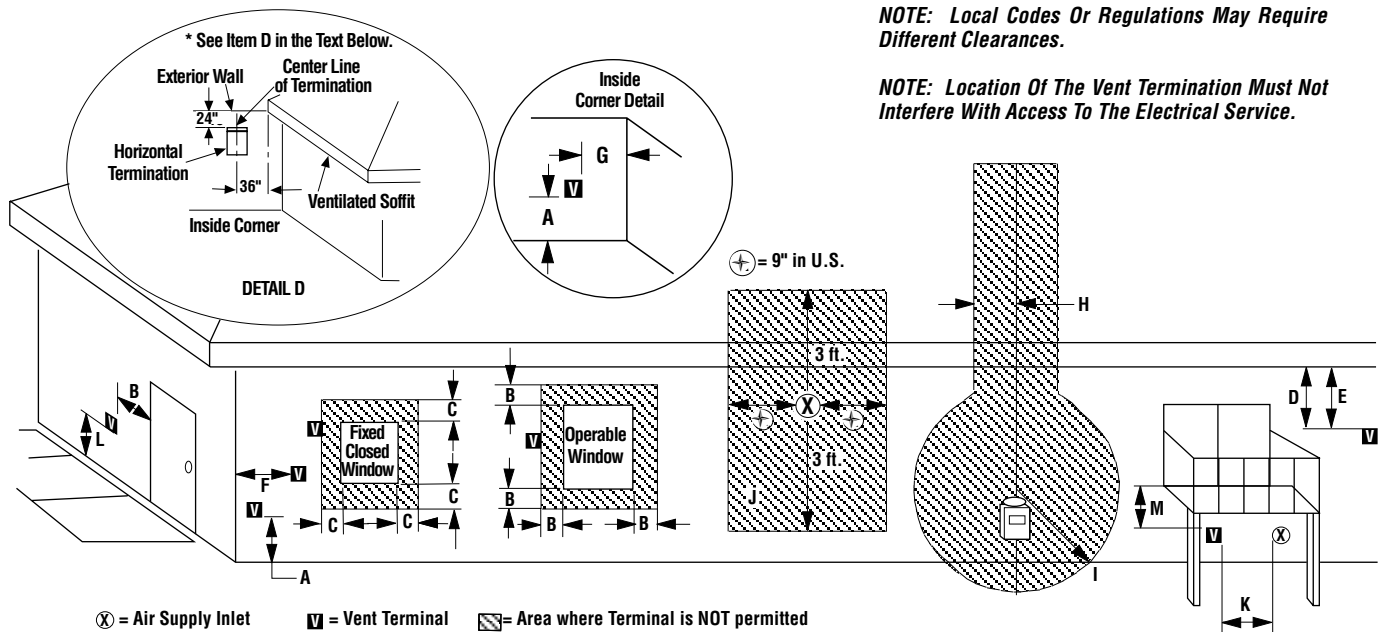

Minimum Clearances	US Installation **
A = Clearance above grade, veranda, porch, deck or balcony.	12 inches (30 cm) **
B = Clearance to window or door that may be opened.	6 in. (15.2 cm) for appliances < 10,000 BTU/hr (3kW), 9 in. (23 cm) for appliances > 10,000 BTU/hr (3kW) and < 50,000 BTU/hr (15kW), 12 inches (30 cm) for appliances > 50,000 BTU/hr (15kW)*
C = Clearance to permanently closed window	9 inches (229 mm) recommended to prevent window condensation
D = Vertical clearance to ventilated soffit located above the terminal within a horizontal distance of 36 in. (91.4cm) from the center line of the terminal	24 inches (61.0 cm)
E = Clearance to unventilated soffit	24 inches (61.0 cm)
F = Clearance to outside corner	5 inches (12.7 cm)
G = Clearance to inside corner	24 inches (61.0 cm)
H = Clearance to each inside of center line extended above meter / regulator assembly	3 feet (91 cm) within a height of 15 feet above the meter / regulator assembly **
I = Clearance to service regulator vent outlet	3 feet (91 cm) **
J = Clearance to non-mechanical air supply inlet to building or the combustion air inlet to any other appliance	6 in. (15.2 cm) for appliances < 10,000 BTU/hr (3kW), 9 in. (23 cm) for appliances > 10,000 BTU/hr (3kW) and < 50,000 BTU/hr (15kW), 12 inches (30 cm) for appliances > 50,000 BTU/hr (15kW)*
K = Clearance to mechanical air supply inlet	3 feet (91 cm) above, if within 10 feet (3 m) horizontally**
L = Clearance above paved sidewalk or paved driveway located on public property	7 feet (2.13 m) ‡
M = Clearance under veranda, porch, deck or balcony	18 in. (46.0 cm) ** ‡
** In accordance with the current ANSI Z223.1 / NFPA 54 National Fuel Codes - Latest Edition.	
‡ A vent shall not terminate directly above a sidewalk or paved driveway which is located between two single family dwellings and serves both dwellings.	
* ‡ Only permitted if veranda, porch, deck or balcony is fully open on a minimum 2 sides beneath the floor.	

Figure 4

MINIMUM CLEARANCES TO COMBUSTIBLES

Appliance And Vent Clearances

The appliance is approved with zero clearance to combustible materials on all sides (as detailed in **Table 5**), with the following exception: **When the unit is installed with one side flush with a wall, the wall on the other side of the unit must not extend beyond the front edge of the unit.** In addition, when the unit is recessed, the side walls surrounding the unit must not extend beyond the front edge of the unit (see **Figure 2 on Page 5**).

APPLIANCE MINIMUM CLEARANCES* Inches (millimeters)	
Sides	1/2 (13), 0 (0) Spacers **
Top Spacers	0 (0)
Floor	0 (0)
Back	1/2 (13), 0 (0) Spacers
Bottom of Appliance To Ceiling	69 (1743)
Vent	3 (76) Top* / 1 (25.4) Sides & Bottom
SERVICE CLEARANCES Feet (meters)	
Front	3 feet (0.9 meters)

Table 5

*Note: 3 in. (75 mm) above any horizontal/inclined vent component.

**Note: See Page 9, Step 1 for clearance requirements to the nailing flange located at each side of the unit and any screw heads adjacent to it.

The appliance should be mounted on a fully supported base extending the full width and depth of the unit. The appliance may be located on or near conventional construction materials. However, if installed on combustible materials, such as carpeting, vinyl tile, etc., a metal or wood barrier covering the entire bottom surface must be used.

Wall Finishes / Surrounds / Mantels

Note: Combustible wall finish materials and/or surround materials must not be allowed to encroach the area defined by the appliance front face (black sheet metal). Never allow combustible materials to be positioned in front of or overlapping the appliance face. See **Figure 6 and Figure 43 on Page 26**.

Non-combustible materials, such as surrounds and other appliance trim, may be installed on the appliance front face with these exceptions: they must not cover any portion of the removable glass panel.

Vertical installation clearances to combustible mantels vary according to the depth of the mantel (see **Figure 5**). Mantels constructed of non-combustible materials may be installed at any height above the appliance opening.

NOTE: We recommend the use of high temperature paint (rated 175° F or higher) on the underside of the mantel.

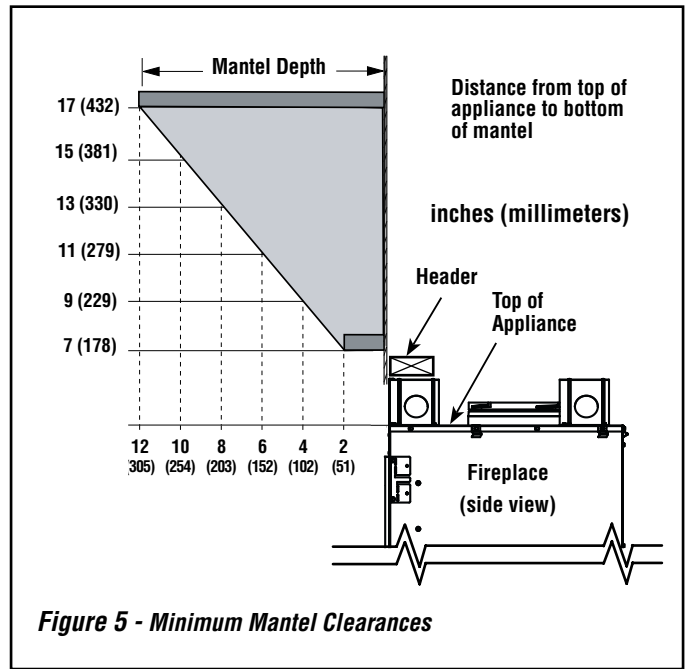

Figure 5 - Minimum Mantel Clearances

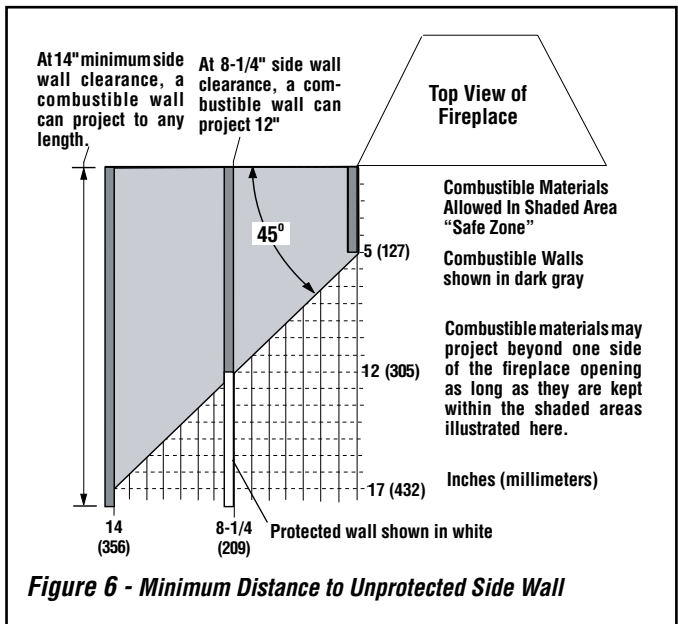

Figure 6 - Minimum Distance to Unprotected Side Wall

! WARNING

Failure to position the parts in accordance with these diagrams or failure to use only parts specifically approved with this appliance may result in property damage or personal injury.

! AVERTISSEMENT

Risque de dommages ou de blessures si les pièces ne sont pas installées conformément à ces schémas et ou si des pièces autres que celles spécifiquement approuvées avec cet appareil sont utilisées.

DETAILED INSTALLATION STEPS

The appliance is shipped with all gas controls and components installed and pre-wired. Remove the shipping carton, exposing the front glass door. Using a Phillips screwdriver, unfasten two (2) screws located at the top of the glass frame (see *Figure 39 on Page 24*). Tilt the top of the glass frame away from the unit. Lift it carefully off the bottom door track and set the door aside, protecting it from inadvertent damage.

TYPICAL INSTALLATION SEQUENCE

The typical sequence of installation is outlined below. However, each installation is unique and may result in variations to the steps described.

See the page numbers references in the following steps for detailed procedures.

- Step 1. (Page 9)** Construct the appliance framing. Position the appliance within the framing and secure with nailing brackets.
- Step 2. (Page 11)** Route gas supply line to the right side.

- Step 3. (Page 12)** Install the vent system and exterior termination.
- Step 4. (Page 18)** Field Wiring
Connect 120 VAC electrical power to the appliance receptacle.
- Step 5. (Page 20)** Remove glass door assembly.
- Step 6. (Page 21)** Make connection to gas supply.
- Step 7. (Page 21)** Install firebox liner kit.
- Step 8. (Page 21)** Verifying appliance operation.
- Step 9. (Page 22)** Install logs, volcanic stone and glowing embers.
- Step 10. (Page 24)** Install glass door assembly.
- Step 11. (Page 24)** Adjust burner to ensure proper flame appearance.
- Step 12. (Page 27)** Attach Safety in Operation Warnings.

Step 1. FRAMING

Frame these appliances as illustrated in *Figure 8 on Page 10*, unless the appliance is to be installed in a corner. See *Figure 9 on Page 11* for corner framing installations. All framing details must allow for a minimum clearance to combustible framing members as shown in *Table 5 on Page 8*.

If the appliance is to be elevated above floor level, a solid continuous platform must be constructed below the appliance.

Headers may be in direct contact with the appliance top spacers but must not be supported by them or notched to fit around them. All construction above the appliance must be self-supporting, **DO NOT** use the appliance for structural support.

The fireplace should be secured to the side framing members using the unit's nailing flanges - one top and bottom on each side of the fireplace front (see *Figure 7*). Use 8d nails or their equivalent.

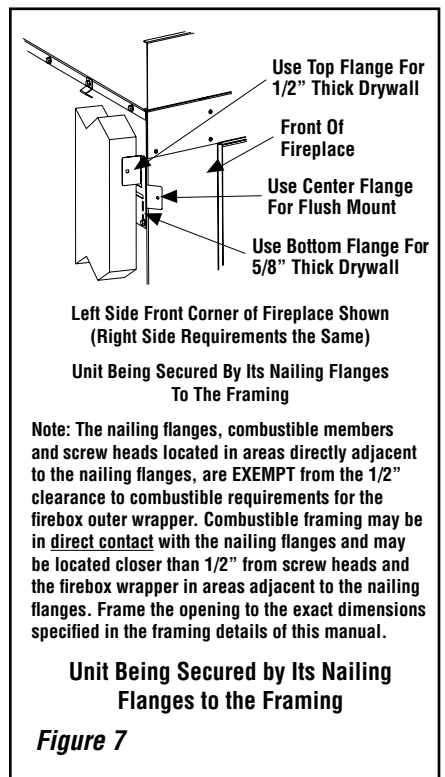

FIREPLACE AND FRAMING SPECIFICATIONS

Framing Dimensions				
Model No.		A	B	C *
LSM40-PV	in.	50-3/4	43	139-1/8
	mm	1289	1092	3534
LSM45-PV	in.	56-7/8	48	144-1/8
	mm	1445	1219	3661

* C = Adaptor Plus 4 Feet Vertical Vent (Min.) and 90° Elbow

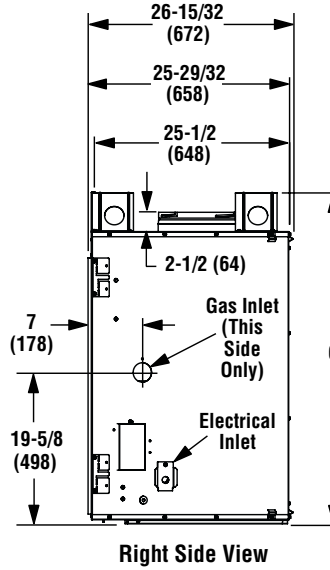
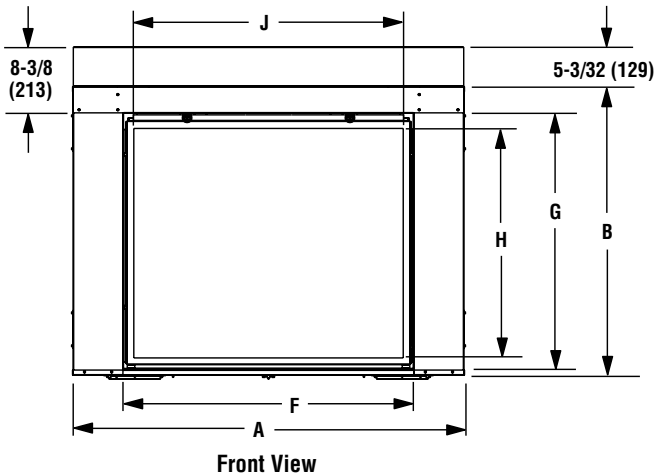
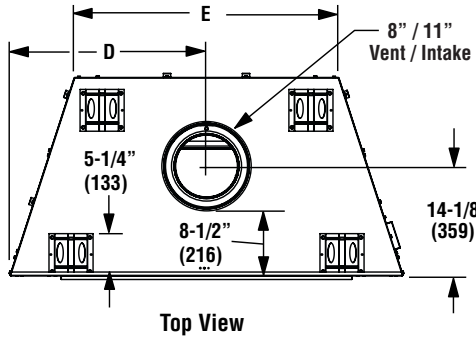
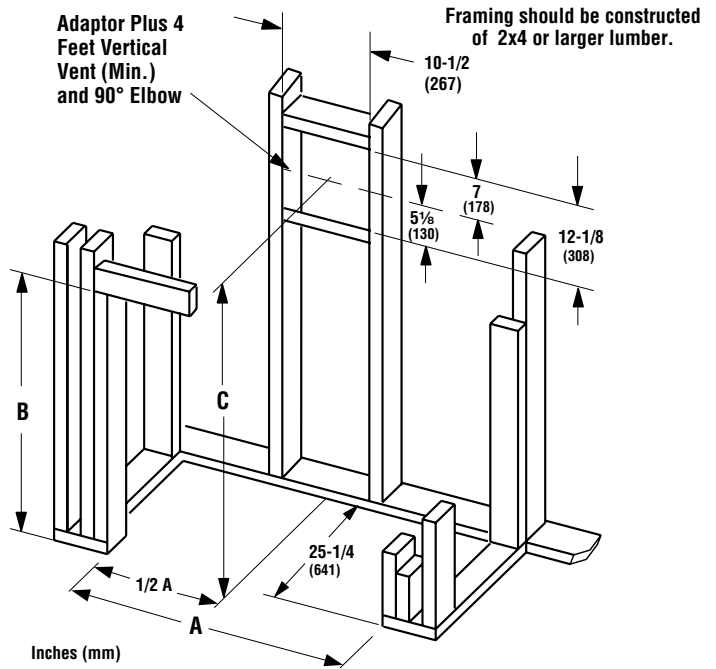

Vent Size	
Co-axial DV Vent Size	4-1/2" Inner 7-1/2" Outer

Notes
Diagrams, illustrations and photographs are not to scale – consult installation instructions. Product designs, materials, dimensions, specifications, colors and prices are subject to change or discontinuance without notice.

Fireplace Dimensions										
Model No.		A	B	C	D	E	F	G	H	J
LSM40-PV	in.	50-5/8	37-1/4	42-7/8	25-5/16	34	37-5/8	33-3/32	29-9/32	34-3/4
	mm	1286	946	1089	643	864	956	840	744	883
LSM45-PV	in.	56-11/16	42-1/4	47-7/8	28-3/8	40-1/8	43-5/8	38-3/32	34-1/2	40-59/64
	mm	1440	1073	1216	721	1019	1108	968	876	1039

Figure 8

Model No.		A	B	C	D
LSM40-PV	in.	50-5/8	83-5/8	59-1/8	41-7/8
	mm	1286	2124	1502	1064
LSM45-PV	in.	56-3/4	89-7/8	63-1/2	44-7/8
	mm	1441	2283	1613	1140

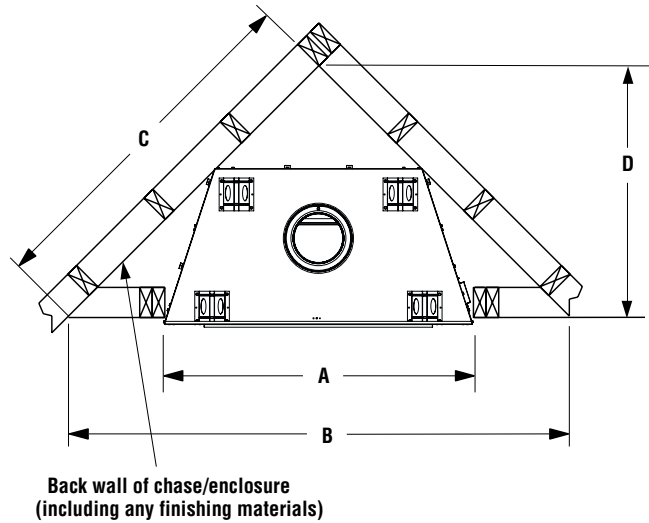

Figure 9 - Corner Framing with Power Vent Termination

Step 2. ROUTING GAS LINE

Route a 1/2" (13 mm) gas line along the inside of the right side framing as shown in **Figure 10**. Gas lines must be routed, constructed and made of materials that are in strict accordance with local codes and regulations.

All appliances are factory-equipped with a flexible gas line connector and 1/2 inch shutoff valve. (See **Step 6 on Page 21**).

The incoming gas line should be piped into the valve compartment and connected in one of the two methods as shown in **Figure 29 on Page 21**.

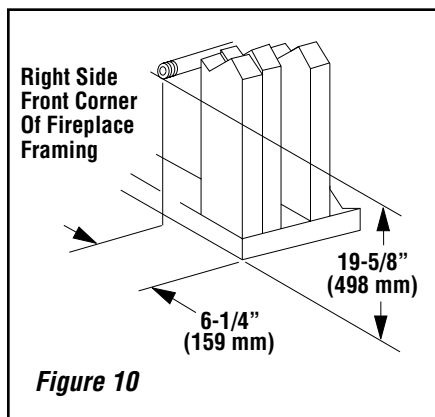

Figure 10

Proper Sizing of Gas Line

Properly size and route the gas supply line from the supply regulator to the area where the appliance is to be installed per requirements outlined in the National Fuel Gas Code, NFPA 54 - latest edition (USA).

Never use galvanized or plastic pipe. Refer to **Table 6** for proper sizing of the gas supply line, if black iron pipe is being used. Gas lines must be routed, constructed and made of materials that are in strict accordance with local codes and regulations. We recommend that a qualified individual such as a plumber or gas fitter be hired to correctly size and route the gas supply line to the appliance. Installing a gas supply line from the fuel supply to the appliance involves numerous considerations of materials, protection, sizing, locations, controls, pressure, sediment, and more. Certainly no one unfamiliar and unqualified should attempt sizing or installing gas piping.

Schedule 40 Black Iron Pipe Inside Diameter (Inches)		
Schedule 40 Pipe Length (feet)	Natural Gas	Propane Gas
0-10	1/2	3/8
10-40	1/2	1/2
40-100	1/2	1/2
100-150	3/4	1/2
150-200	3/4	1/2

Table 6

Notes:

- All appliances are factory-equipped with a flexible gas line connector and 1/2 inch shutoff valve (see **Figure 29 on Page 21**).
- See **Massachusetts Requirements on Page 4** for additional requirements for installations in the state of Massachusetts in the USA.
- The gas supply line should Not be connected to the appliance until **Step 6 (Page 21)**.
- A pipe joint compound rated for gas should be used on the threaded joints. **Ensure propane resistant compounds are used in propane applications.** Be very careful that the pipe compound does not get inside the pipe.
- It is recommended to install a sediment trap in the supply line as close as possible to the appliance (see **Figure 29 on Page 2**). Appliances using Propane should have a sediment trap at the base of the tank.
- Check with local building official for local code requirements (i.e. are below grade penetrations of the gas line allowed?, etc).

IMPORTANT: If propane is used, be aware that if tank size is too small (i.e. under 100-lbs, if this is the only gas appliance in the dwelling. Ref. NFPA 58), there may be loss of pressure, resulting in insufficient fuel delivery (which can result in sooting, severe delayed ignition or other malfunctions). Any damage resulting from an improper installation, such as this, is not covered under the limited warranty.

Step 3. INSTALL THE VENT SYSTEM

General Information

These instructions should be used as a guideline and do not supersede local codes in any way. Install venting according to local codes, these instructions, the current National Fuel Gas Code (ANSI-Z223.1) in the USA.

These fireplaces are designed, tested and listed for operation and installation with, and only with, Secure Vent™ (SV4.5) Direct-Vent System Components, manufactured by Security Chimneys International. These approved vent system components are labeled for identification. DO NOT use any other manufacturer's vent components with these appliances.

Ensure clearances are in accordance with local installation codes and the requirements of the gas supplier.

Dégagement conforme aux codes d'installation locaux et aux exigences du fournisseur de gaz.

Use only approved venting components. See *Approved Vent Components* on Page 2.

These fireplaces must be vented directly to the outside.

The vent system may not service multiple appliances, and must never be connected to a flue serving a solid fuel burning appliance. The vent pipe is tested to be run inside an enclosed wall (such as a chase). There is no requirement for inspection openings in the enclosing wall at any of the joints in the vent pipe.

Venting System

With the appliance secured in framing, determine vent routing and identify the exterior termination location. The following sections describe horizontal (exterior wall) vent applications. A list of approved venting components is shown on Page 28.

Power Vent Components

Locate the fireplace as per the instructions in this manual. Make the following modifications to add the components used with the Power Vent Kits. This kit can only be used in conjunction with "Direct-Vent" series electronic versions of Lennox™ Fireplaces. This installation must conform with local codes or, in the absence of local codes, with the Natural Fuel Gas Code, ANSI Z223.1/NFPA 54.

CAUTION: This Power Vent Kit cannot be used with Millivolt appliances. Use kit only with the Electronically controlled fireplaces listed for its use as shown in this document.

POWER VENT COMPONENTS

Item No.	Part Number	Description	Qty.
1	604187-01	Adaptor Assembly With Probe	1
2	601970-01	Vacuum Hose	1
3	601451-01	Termination Assembly	1
4	74L61	SV Termination Adaptor (SV4.5RCH)	1
5	102010-01	Strain Relief - 3/8"	1
6	H2246	Firestop Assembly (Horizontal)	1 </td
7	102022-01	Hose Clamp - 11/32"	2
8	P-8-7102	Snap Bushing	1
9		Ring Terminal - #10	2
10		Insulated 1/4" Male Terminal	4

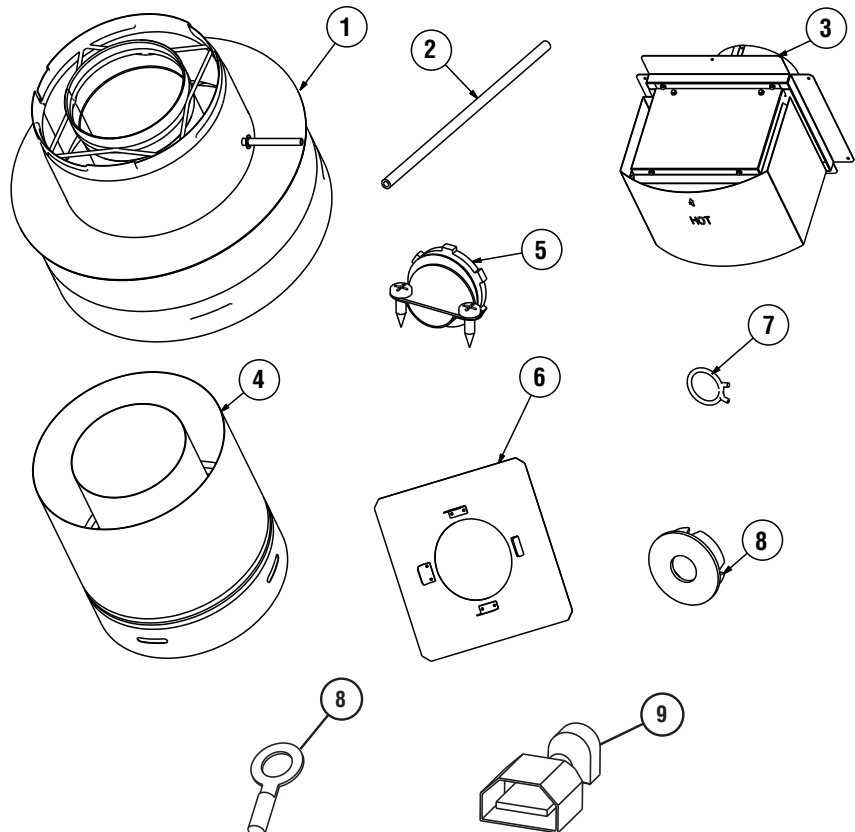

Figure 11 - Power Kit Components

NOTE: DIAGRAMS & ILLUSTRATIONS ARE NOT TO SCALE.

VENT SECTION LENGTHS

Determine the number of straight vent sections required. 4-1/2" (114 mm), 10-1/2" (267 mm), 22-1/2" (572 mm), 34-1/2" (876 mm) and 46-1/2" (1181 mm) net section lengths are available. Refer to the Vent Section Length Chart.

Vertical (Offset) Installation

Analyze the vent routing and determine the quantities of vent sections and number of elbows required. Refer to **Figures 16 and 17 on Page 15** showing vent run requirements to aid in selecting the type of vertical installation desired. Vent sections are available in net lengths of 4-1/2" (114 mm), 10-1/2" (267 mm), 22-1/2" (572 mm), 34-1/2" (876 mm) and 46-1/2" (1181 mm). Refer to the **Vent Section Length Chart** for an aid in selecting length combinations. Elbows are available in 90° and 45° configurations. Refer to **Figure 15 on Page 14** for the SV4.5 E45 and SV4.5 E90 elbow dimensional specifications.

Where required, a **telescopic vent section (SV4.5LA)** may be used to provide the installer with an option in installing in tight and confined spaces or where the vent run made up of fixed length pieces develops a joint in a undesirable location, or will not build up to the required length. The SV4.5LA Telescopic Vent Section has an effective length of from 1-1/2" (38 mm) to 6-3/4" (171 mm). The SV4.5LA is fitted with a dimpled end (identical to a normal vent section component) and a plain end with 3 pilot holes. Slip the dimpled end over the locking channel end of a standard SV4.5 vent component the required distance and secure with three screws.

Maintain a minimum 1" (25 mm) clearance to combustible materials for all vertical elements. Clearances for all horizontal elements are 3" (76 mm) on top, 1" (25 mm) on sides and 1" (25 mm) on the bottom.

Effective Vent Length	
Model	Effective Length
SV4.5L6	4-1/2"
SV4.5L12	10-1/2"
SV4.5L24	22-1/2"
SV4.5L36	34-1/2"
SV4.5L48	46-1/2"

Table 7

VENT SECTION LENGTH CHART							TOTAL QTY
Nominal Section Length (inches)	6	12	24	36	48		
Net Section Length (inches)	4-1/2	10-1/2	22-1/2	34-1/2	46-1/2		
Height of Vent	Number of Vent Sections						
inches	ft						
4.5	0.375	1	0	0	0	0	1
9	0.75	2	0	0	0	0	2
10.5	0.875	0	1	0	0	0	1
15	1.25	1	1	0	0	0	2
22.5	1.875	0	0	1	0	0	1
31.5	2.625	0	3	0	0	0	3
34.5	2.875	0	0	0	1	0	1
37.5	3.125	1	1	1	0	0	3
43.5	3.625	0	2	1	0	0	3
45	3.75	0	0	2	0	0	2
46.5	3.875	0	0	0	0	1	1
51	4.25	1	0	0	0	1	2
55.5	4.625	0	1	2	0	0	3
57	4.75	0	0	1	1	0	2
67.5	5.625	0	0	3	0	0	3
69	5.75	0	0	0	2	0	2
73.5	6.125	1	0	0	2	0	3
79.5	6.625	0	1	0	2	0	3
81	6.75	0	0	0	1	1	2
91.5	7.625	0	0	2	0	1	3
93	7.75	0	0	0	0	2	2
97.5	8.125	1	0	0	0	2	3
103.5	8.625	0	0	0	3	0	3
108	9	1	0	0	3	0	4
117	9.75	1	0	5	0	0	6
118.5	9.875	1	1	0	3	0	5
126	10.5	0	0	1	3	0	4
130.5	10.875	1	0	1	3	0	5
135	11.25	0	0	6	0	0	6
139.5	11.625	0	0	0	0	3	3
142.5	11.875	1	0	0	4	0	5
144	12	1	0	0	0	3	4
154.5	12.875	1	1	0	0	3	5
160.5	13.375	0	2	0	0	3	5
172.5	14.375	0	0	0	5	0	5
177	14.75	1	0	0	5	0	6
186	15.5	0	0	0	0	4	4
196.5	16.375	0	1	0	0	4	5
207	17.25	0	0	0	6	0	6
211.5	17.625	1	0	0	6	0	7
217.5	18.125	0	1	0	6	0	7
229.5	19.125	0	0	1	6	0	7
232.5	19.375	0	0	0	0	5	5
241.5	20.125	0	0	0	7	0	7
246	20.5	1	0	0	7	0	8
252	21	0	1	0	7	0	8

VENT SECTION LENGTH CHART							TOTAL QTY
Nominal Section Length (inches)	6	12	24	36	48		
Net Section Length (inches)	4-1/2	10-1/2	22-1/2	34-1/2	46-1/2		
Height of Vent	Number of Vent Sections						
inches	ft						
276	23	0	0	0	8	0	8
279	23.25	0	0	0	0	6	6
280.5	23.375	1	0	0	8	0	9
289.5	24.125	0	1	0	0	6	7
301.5	25.125	0	0	1	0	6	7
310.5	25.875	0	0	0	9	0	9
325.5	27.125	0	0	0	0	7	7
330	27.5	1	0	0	0	7	8
345	28.75	0	0	0	10	0	10
349.5	29.125	1	0	0	10	0	11
372	31	0	0	0	0	8	8
379.5	31.625	0	0	0	11	0	11
418.5	34.875	0	0	0	0	9	9
465	38.75	0	0	0	0	10	10
475.5	39.625	0	1	0	0	10	11
480	40	1	1	0	0	10	11
492	41	1	0	1	0	10	12
499.5	41.625	0	0	0	1	10	11
504	42	1	0	0	1	10	12
511.5	42.625	0	0	0	0	11	11
520.5	43.375	0	2	0	1	11	14
531	44.25	0	2	2	0	11	15
538.5	44.875	1	0	0	2	11	14
549	45.75	1	0	2	1	11	15
558	46.5	0	0	0	0	12	12
562.5	46.875	1	0	0	0	12	13
568.5	47.375	0	1	0	0	12	13
573	47.75	1	1	0	0	12	14
580.5	48.375	0	0	1	0	12	13
589.5	49.125	0	1	2	2	10	15
595.5	49.625	1	1	1	0	12	15
604.5	50.375	0	0	0	0	13	13
615	51.25	0	1	0	0	13	14
625.5	52.125	0	2	0	0	13	15
631.5	52.625	1	0	1	0	13	15
637.5	53.125	0	1	1	0	13	15
651	54.25	0	0	0	0	14	14
655.5	54.625	1	0	0	0	14	15
672	56	0	2	0	0	14	16
678	56.5	1	0	1	0	14	16
688.5	57.375	1	1	1	0	14	17
697.5	58.125	0	0	0	0	15	15
702	58.5	1	0	0	0	15	16
712.5	59.375	1	1	0	0	15	17
720	60	0	0	1	0	15	16

Note: Convert inches into metric equivalent measurement, as follows:

- Millimeters (mm) = Inches x 25.4
- Centimeters (cm) = Inches x 2.54
- Meters (M) = Inches x .0254

A. Frame ceiling opening - Use a plumb line from the ceiling above the appliance to locate center of the vertical run. Cut and/or frame an opening, 10-1/2" x 10-1/2" (267 mm x 267 mm) inside dimensions, about this center mark (*Figure 12*).

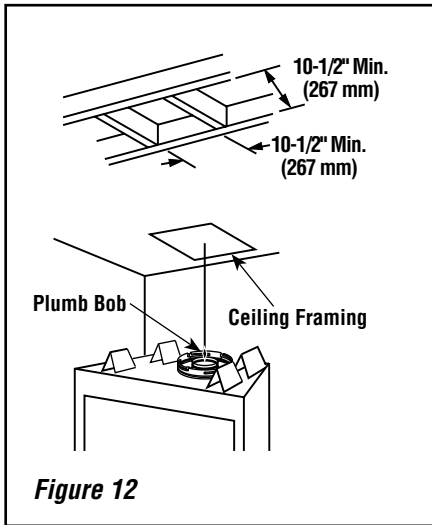

Figure 12

B. Attach adaptor (with probe) to appliance collar. Secure Vent™ SV4.5 direct-vent system components are unitized concentric pipe components featuring positive twist lock connections (*see Figure 13*).

All of the appliances covered in this document are fitted with collars having locking inclined channels. The dimpled end of the adaptor fits over the appliance collar to create the positive twist lock connection.

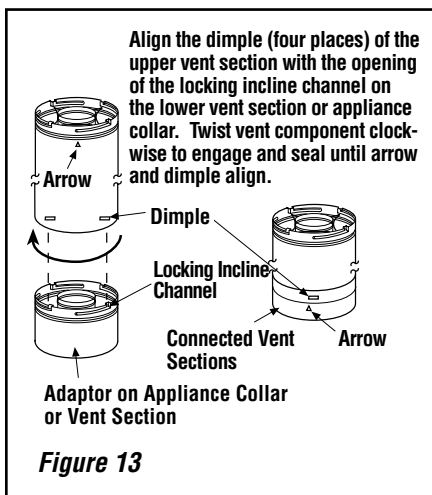

Figure 13

To attach a vent component to the adaptor on appliance collar, align the dimpled end over the adaptor collar, adjusting the radial alignment until the four locking dimples are aligned with the inlet of the four inclined channels on the collar (*refer to Figure 13*). Push the vent component against the collar until it fully engages, then twist the component clockwise, running the dimples down and along the incline channels until they seat at the end of the channels.

The unitized design of the **Secure Vent** components will engage and seal both the inner and outer pipe without the need for sealant or screws. If desired a #6 x 1/2" screw may be used at the joint, but it is not required as the pipe will securely lock when twisted.

C. Attach vent components to each other - Other vent sections may be added to the previously installed section in accordance with the requirements shown in *Figures 16 and 17 on Page 15*.

To add another vent component to a length of vent run, align the dimpled end over the inclined channel end of the previously installed section, adjusting the radial alignment until the four locking dimples are aligned with the inlets of the four incline channels of the previous section.

Push the vent component against the previous section until it fully engages, then twist the component clockwise running the dimples down and along the incline channels until they seat at the end of the channels. **This seating position is indicated by the alignment of the arrow and dimple as shown in Figure 13.**

D. Install firestop/spacer at ceiling - When using Secure Vent, use SV4.5VF firestop/spacer at ceiling joists. If there is living space above the ceiling level, the firestop/spacer must be installed on the bottom side of the ceiling. If attic space is above the ceiling, the firestop/spacer must be installed on the top side of the joist. Route the vent sections through the framed opening and secure the firestop/spacer with 8d nails or other appropriate fasteners at each corner. **Remember to maintain 1" (25 mm) clearance to combustibles, framing members, and attic or ceiling insulation when running vertical chimney sections.** Attic insulation shield (H3907) may be used to obtain the required clearances indicated here. See installation accessories on *Page 28*. The gap between the vent pipe and a vertical firestop can be sealed with non-combustible caulking.

E. Support the vertical vent run sections -

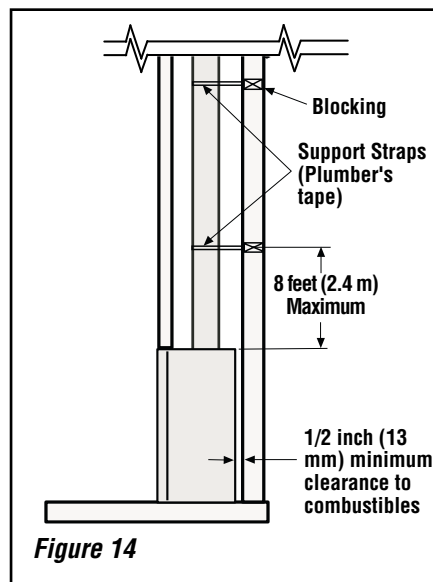

Figure 14

Note - Proper venting support is very important. The weight of the vent must not be supported by the fireplace in any degree.

Support the vertical portion of the venting system every 8 feet (2.4 m) above the fireplace vent outlet. One method of support is by utilizing field provided support straps (conventional plumber's tape). Secure the plumber's tape to the framing members with nails or screws. Strap the tape around the vent, securing the ends of the tape to the framing. If desired, sheet metal screws #6 x 1/2" length may be used to secure the support straps to the vent pipe.

F. Change vent direction to horizontal/inclined run - At transition from or to a horizontal/inclined run, install the SV4.5 E45 and SV4.5 E90 elbows in the same manner as the straight vent sections. The elbows feature a twist section to allow them to be routed about the center axis of their initial collar section to align with the required direction of the next vent run element. **Twist elbow sections in a clockwise direction only so as to avoid the possibility of unlocking any of the previously connected vent sections (see Figures 13 and 15).**

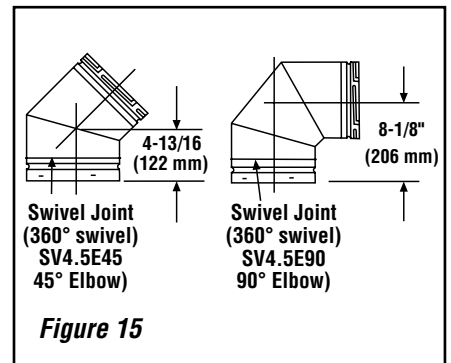

Figure 15

G. Continue installation of horizontal/inclined sections - Continue with the installation of the straight vent sections in horizontal/inclined run as described in **Step C**. Install support straps every 3' (914 mm) along horizontal/inclined vent runs using conventional plumber's tape (*see Page 15, Figure 16*). **It is very important that the horizontal/inclined run be maintained in a straight (no dips), slightly elevated plane. The recommended incline is approximately 1/4" per foot (20 mm per meter) horizontal, in a direction away from the fireplace.** The rise per foot run ratios that are smaller are acceptable all the way down to at or near level. Use a carpenter's level to measure from a constant surface and adjust the support straps as necessary.

It is important to maintain the required clearances to combustibles: 1" (25 mm) at all sides for all vertical runs; and 3" (76 mm) at the top, 1" (25 mm) at sides, and 1" (25 mm) at the bottom for all horizontal/inclined runs.

VENT FIGURES

Notes:

- **Secure Vent™** components (rigid vent pipe and terminal) are shown in the Figures.
- Two 45 degree elbows may be used in place of one 90 degree elbow.
- SV4.5VF (Secure Vent) firestop/spacer must be used anytime vent pipe passes through a combustible floor or ceiling. SV4.5HF (Secure Vent) firestop/spacer must be used anytime vent pipe passes through a combustible wall.
- It is very important that the horizontal/inclined run be maintained in a straight (no dips), slightly elevated plane. The recommended incline is approximately 1/4" per foot (20 mm per meter) horizontal, in a direction away from the fireplace. The rise per foot run ratios that are smaller are acceptable all the way down to at or near level.

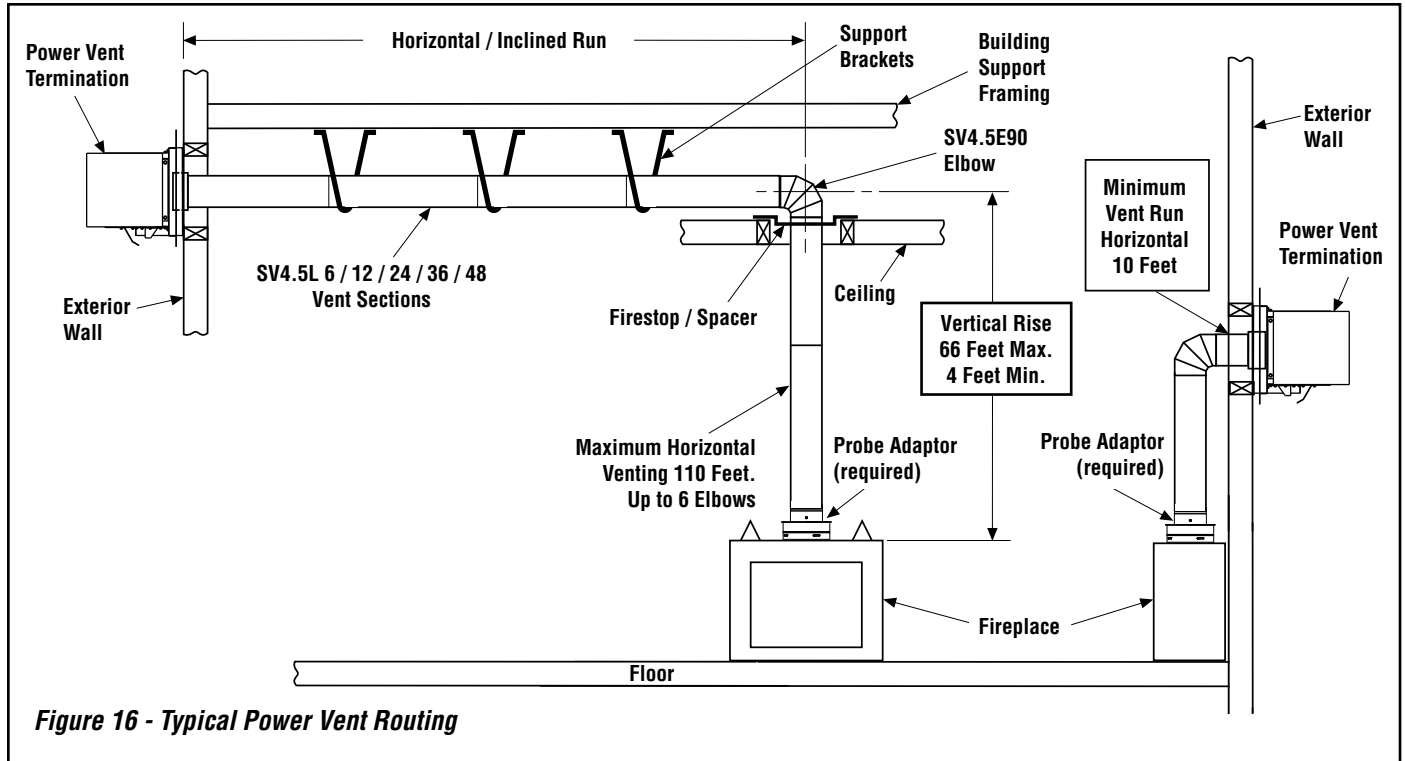

Figure 16 - Typical Power Vent Routing

POWER VENT VENTING CHART		
Maximum Number Of Elbows	-	6
Maximum Feet Of Run	A + B	110 feet
Minimum Horizontal Run	B	10 feet
Minimum Vertical Run	A	Adaptor Plus 4 Feet Vertical Vent (Min.) and 90° Elbow
Maximum Vertical Rise	A	66 feet

MINIMUM CLEARANCES TO COMBUSTIBLES	
Vertical Vent Pipe	1.0 in. (25.4 mm)
Horizontal Vent Pipe	Top - 3.0 in. (76.2 mm) Sides - 1.0 in. (25.4 mm) Bottom - 1.0 in. (25.4 mm)

Figure 17

HORIZONTAL (OUTSIDE WALL) TERMINATION SYSTEM

See **Figures 16 and 17 on Page 15** illustrating the various horizontal venting configurations that are possible for use with these appliances. The table in **Figure 17 on Page 15** shows each system's minimum and maximum vertical and horizontal length values that can be used to design and install the vent components in a variety of applications.

The horizontal vent system terminates through an outside wall. Building Codes limit or prohibit terminating in specific areas. Refer to **Figure 4 on Page 7** for location guidelines.

Secure Vent™ SV4.5 direct-vent system components are unitized concentric pipe components featuring positive twist lock connection, (refer to **Figure 13 on Page 14**). All of the appliances covered in this document are fitted with collars having locking inclined channels. The dimpled end of the vent components fit over the appliance collar to create the positive twist lock connection.

A. Plan the vent run -

Analyze the vent routing and determine the types and quantities of sections required 4-1/2" (114 mm), 10-1/2" (267 mm), 22-1/2" (572 mm), 34-1/2" (876 mm) and 46-1/2" (1181 mm) net section lengths are available. Make allowances for elbows as indicated in **Figure 15 on Page 14**.

Maintain a minimum 1" (25 mm) clearance to combustibles on the vertical sections. Clearances for the horizontal runs are; 3" (76 mm) on top, 1" (25 mm) on sides, and 1" (25 mm) at the bottom.

B. Frame exterior wall opening -

Locate the center of the vent outlet on the exterior wall according to the dimensions shown in **Figure 8 on Page 10**.

Cut and/or frame an opening, 10-1/2" x 12-1/8" (267 mm x 308 mm) inside dimensions, about this center.

C. Frame ceiling opening - If the vertical route is to penetrate a ceiling, use plumb line to locate the center above the appliance. Cut and/or frame an opening, 10-1/2" x 10-1/2" (267 mm x 267 mm) inside dimensions, about this center (refer to **Figure 12 on Page 14**).

D. Attach vent components to appliance - To attach a vent component to the appliance collar, align the dimpled end over the collar, adjusting the radial alignment until the four locking dimples are aligned with the inlets of the four incline channels on the collar (refer to **Figure 13 on Page 14**).

Push the vent component against the collar until it fully engages, then twist the component clockwise, running the dimples down and along the incline channels until they seat at the end of the channels. The unitized design of the **Secure Vent** components will engage and seal both the inner and outer pipe elements with the same procedure. Sealant and securing screws are not required.

E. Attach vent components to each other -

Other vent sections may be added to the previously installed section in accordance with the requirements of the vent tables. To add another vent component to a length of vent run, align the dimpled end of the component over the inclined channel end of the previously installed section, adjusting the radial alignment until the four locking dimples are aligned with the inlets of the four incline channels of the previous section. Push the vent component against the previous section until it fully engages, then twist the component clockwise running the dimples down and along the incline channels until they seat at the end of the channels. **This seating position is indicated by the alignment of the arrow and dimple as shown in Figure 13 on Page 14.**

F. Install firestop/spacer at ceiling -

When using **Secure Vent**, use SV4.5VF firestop/spacer at ceiling joists. If there is living space above the ceiling level, the firestop/spacer must be installed on the bottom side of the ceiling. If attic space is above the ceiling, the firestop/spacer must be installed on the top side of the joist. Route the vent sections through the framed opening and secure the firestop/spacer with 8d nails or other appropriate fasteners at each corner.

Remember to maintain 1" (25 mm) clearance to combustibles, framing members, and attic or ceiling insulation when running vertical chimney sections.

G. Support the vertical run sections -

On the vertical run, support the venting system every 8 feet (2.4m) above the fireplace vent outlet with field provided support straps (Plumber's tape). Attach the straps to the vent pipe and secure to the framing members with nails or screws.

H. Change vent direction - At transition from or to a horizontal/inclined run, install the SV4.5E45 and SV4.5E90 elbows in the same manner as the straight vent sections. The elbows feature a twist section to allow them to be routed about the center axis of their initial collar section to align with the required direction of the next vent run element. **Twist elbow sections in a clockwise direction only so as to avoid the possibility of unlocking any of the previously connected vent sections (see Figure 13 on Page 14).**

I. Continue installation of horizontal/inclined sections -

Continue with the installation of the straight vent sections in horizontal/inclined run as described in **Step E**. Install support straps every 3 feet (914 mm) along horizontal/inclined vent runs using conventional plumber's tape.

See **Figure 16 on Page 15**. **It is very important that the horizontal/inclined run be maintained in a straight (no dips), slightly elevated plane. The recommended incline is approximately 1/4" per foot (20 mm per meter) horizontal, in a direction away from the fireplace.** The rise per foot run ratios that are smaller are acceptable all the way down to at or near level. Use a carpenter's level to measure from a constant surface and adjust the support straps as necessary.

Installing Power Vent Termination

J. Assemble vent run to exterior wall - If not previously measured, locate the center of the vent on the exterior wall. Prepare an opening as described in this manual. Assemble the vent system to a point where the terminus of the last section is within 8 inches of the outside wall surface where the power vent is to be mounted (refer to **Figure 19 on Page 17**).

If the terminus of the last section is not within this distance, use the **telescopic vent section SV4.5LA**, as the last vent section. For wall thicknesses greater than that shown in **Figure 19 (Page 17)**, refer to **Table 8 (Page 17)** for the additional venting components needed (in addition to the termination and adaptor) for a particular range of wall thicknesses.

K. Attach termination adaptor - Attach the adaptor (adaptor - SV4.5RCH - provided with the power vent kit) to the vent section telescoping vent section, or elbow, as shown in **Figures 18 and 19 (Page 17)** in the same manner as any SV4.5 vent component.

L. Install Firestop/Spacer at exterior wall -

Install SV4.5HF Firestop/Spacer, provided with the power vent kit, over the opening at the exterior side of the framing, long side up, with the 3 inch spacer clearance at the top as shown in **Figure 18**, and nail into place.

(The Firestop/Spacer may also be installed over the opening at the interior side of the framing).

M. Install the Power Vent termination -

For the last step, from outside the exterior wall, slide the collars of the termination onto the adaptor (the outer inside the outer and the inner outside the inner) until the termination seats against the exterior wall surface to which it will be attached. Orient the housing of the termination with the arrow pointed upwards. Secure the termination to the exterior wall. **The termination must not be recessed into the exterior wall or siding** by more than the 1-1/4" (32 mm) as shown in **Figure 19**.

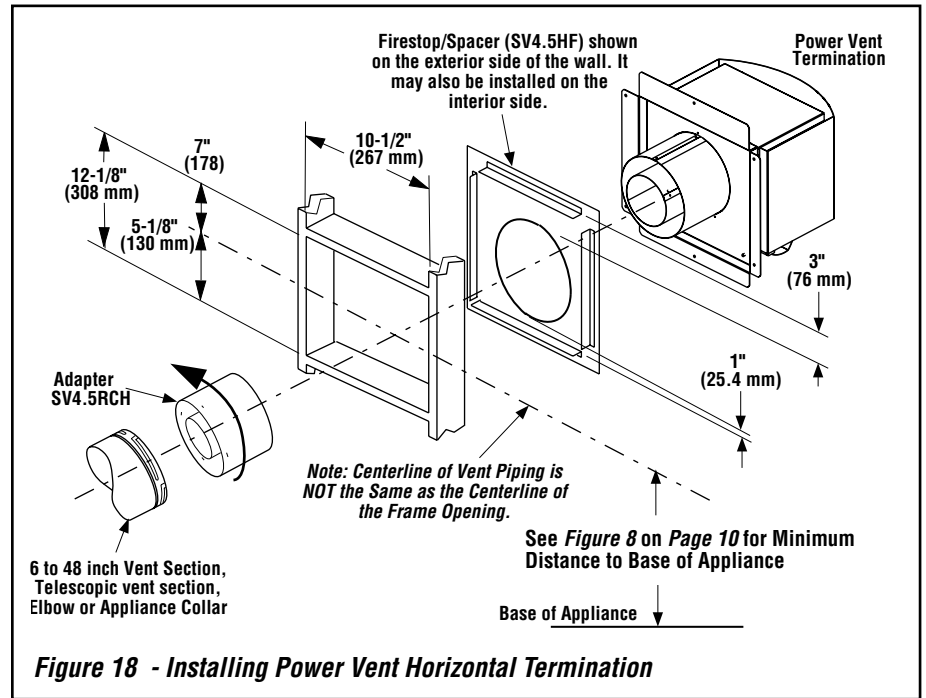

Figure 18 - Installing Power Vent Horizontal Termination

The Power Vent termination has been designed to perform in a wide range of weather conditions. Our terminations meet or exceed industry standards.

When selecting the location of your termination, do not place the termination where water from eaves and adjoining roof lines may create a heavy flow of cascading water onto the terminations. If the termination must be placed where the possibility of cascading water exists, it is the responsibility of the builder to direct the water away from the termination cap by using gutters or other means.

Take care to carefully follow the Installation Instructions for the termination, including the use of silicone caulking where required.

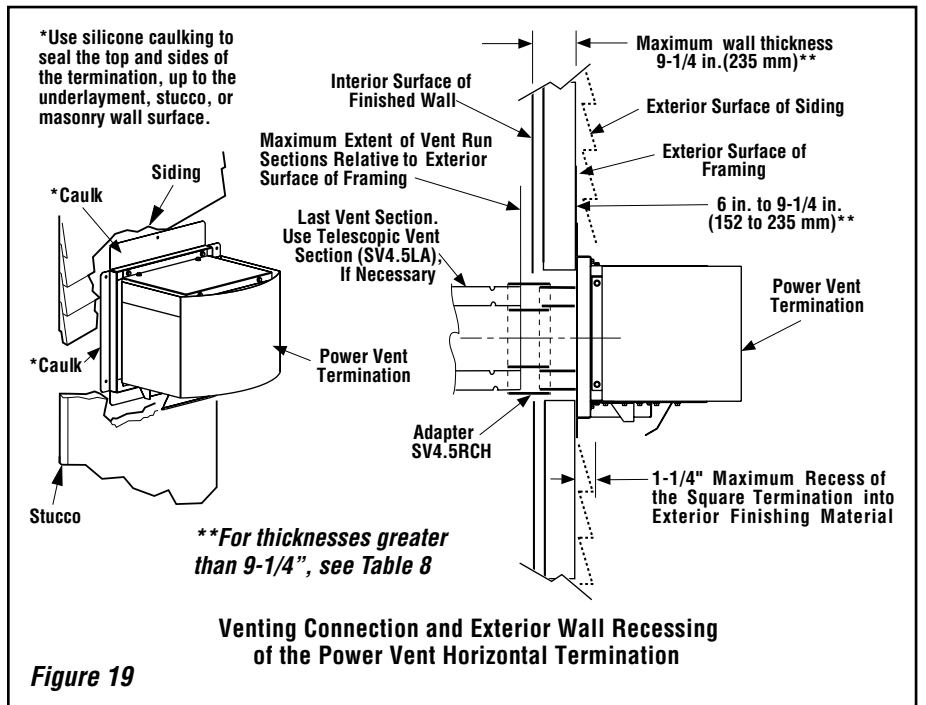

Figure 19

See Table 8 as an aid in venting component selection for a particular range of exterior wall thicknesses.

IMPORTANT: The vent termination is hot while in operation and for a period of time following the use of the fireplace. Young children should be carefully supervised when they are in the same area as a hot termination.

Venting Components Required for Various Exterior Wall Thicknesses, When Using The Power Vent Termination	
Vent Components Required	Exterior Wall Thickness - inches (mm)
Termination Kit Only	6 to 9-1/4 (152 to 235)
Termination Kit and 6 In. Vent Section (SV4.5L6)	10-3/4 to 14 (273 to 356)
Termination Kit and 12 in. Vent Section (SV4.5L12)	16-3/4 to 20 (426 to 508)
Termination Kit and Telescopic Section (SV4.5L12)	11-3/4 to 20 (299 to 508)

Table 8

Step 4. FIELD WIRING

CAUTION: Label all wires prior to disconnection when servicing controls. Wiring errors can cause improper and dangerous operation.

ATTENTION: Au moment de l'entretien des commandes, étiquetez tous les fils avant de les débrancher. Des erreurs de câblage peu-vent entraîner un fonctionnement inadéquat et dangereux.

Verify proper operation after servicing.

S'assurer que l'appareil fonctionne adéquatement une fois l'entretien terminé.

CAUTION: Ground supply lead must be connected to the wire attached to the green ground screw located on the outlet box. See Figures 26 and 27 on Page 20. Failure to do so will result in a potential safety hazard. The appliance must be electrically grounded in accordance with local codes or, in the absence of local codes, the National Electrical Code, ANSI/NFPA 70-latest edition.

Route Wiring

NOTE: Electrical wiring must be performed by a qualified electrician.

- Install the strain relief in the hole provided on the right side of fireplace for the electrical wiring (refer to Figure 20).
- **Standard Instruction** (For use when access to the termination is difficult because of height or other reasons).
- Locate a locally procured electrical junction box within reach of the termination wiring pigtail (refer to Figure 22 on Page 19) and route the pigtail to the junction box as the termination is installed.
- Route 14 gauge AWG grounded Romex wiring (not provided) from the fireplace to the just installed junction box close to the termination. Ensure the wiring is safety plated to prevent damage by framing nails and finish drywall screws. Route the wire into the lower control compartment and cut to length before installing the terminals. Install provided wiring hardware on the ends of the Romex wire.

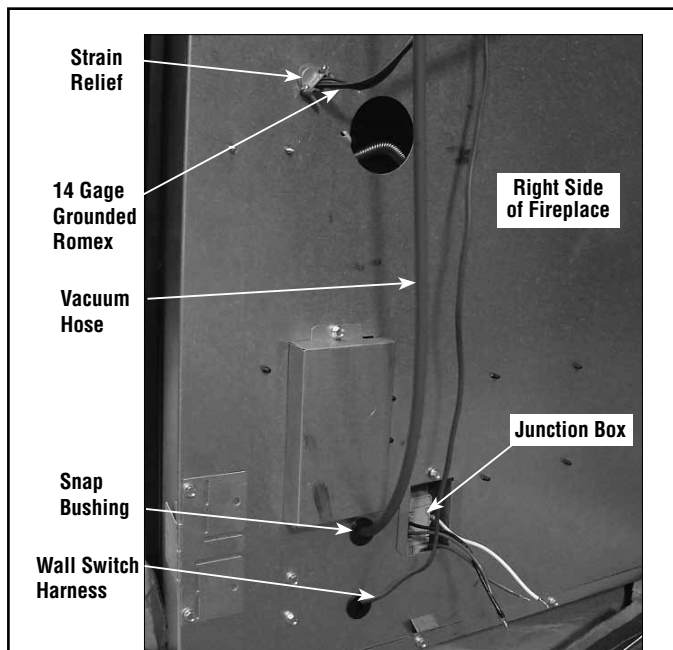

Figure 20

- Refer to Figure 24 on Page 19 and install the electrical hardware on the ends of the Romex wiring. Male terminals on the Black and White wires, and ring terminals on the ground wire.
- Using standard electrical practices and the terminals provided, connect the three wires of the Romex cable to the termination pigtail within the Electrical junction box. Ensure ground.
- The fireplace end of the Romex will be addressed in **Connecting The Power Vent To The Fireplace Control System**.

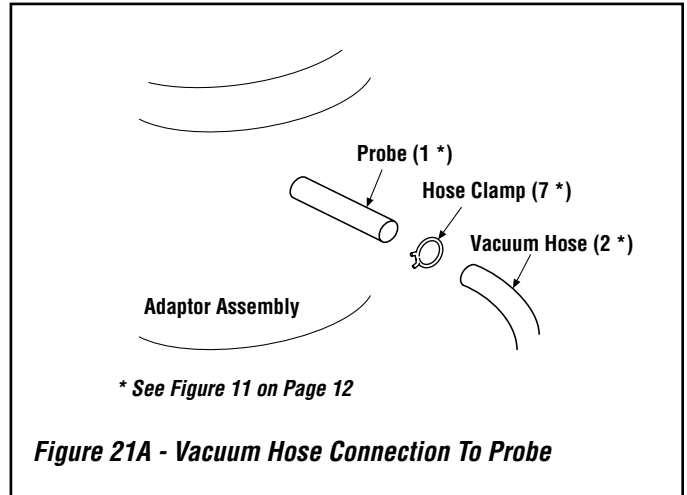

Figure 21A - Vacuum Hose Connection To Probe

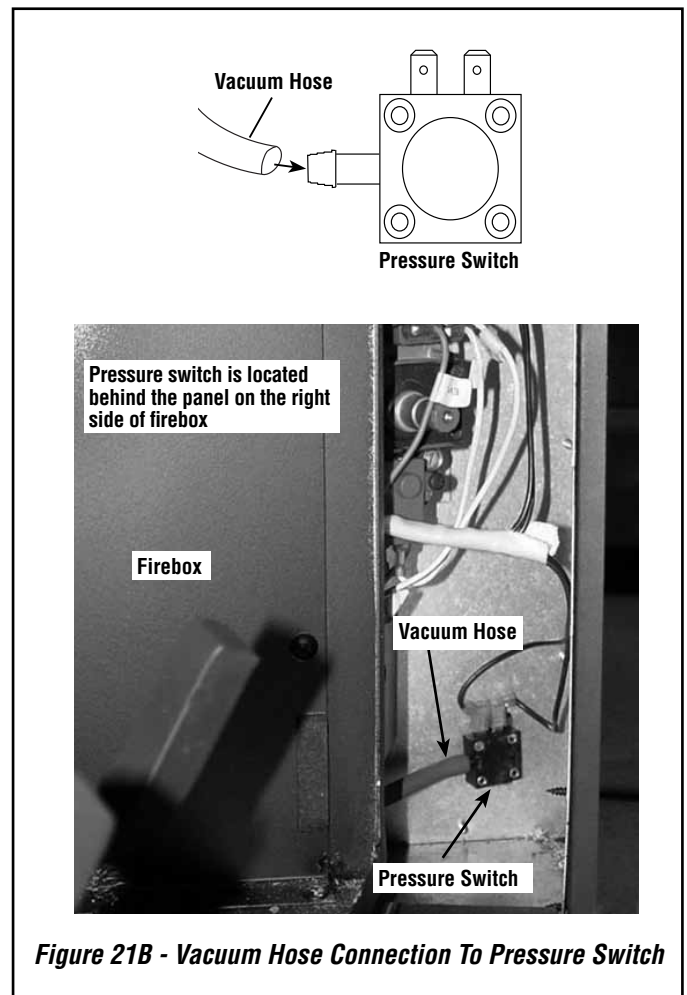

Figure 21B - Vacuum Hose Connection To Pressure Switch

Wiring - Fireplace (See Figures 26 and 27 on Page 20)

Note: These electronic appliances must be connected to the main power supply. The gas valve is set in place and pre-wired at the factory.

1. Route a 3-wire 120Vac 60Hz 1ph power supply to the appliance junction box.
2. Remove the electrical inlet cover plate from the side of the unit by removing the plate's securing screws (see Figure 8 on Page 10).
3. Remove the cover plate's knockout and then feed the power supply wire through the knockout opening and into the unit junction box.
4. Connect the black power supply wire to the power outlet's red pigtail lead and the white power supply wire to the common terminal of the outlet as shown in Figures 26 and 27 on Page 20.
5. Connect the ground supply wire to the pigtail lead attached to outlet's green ground screw.
6. Appliance-mounted ON/OFF burner control switch (rocker switch) is factory installed. Optional wall-mounted switch, or one of the optional remote control kits may also be used.
7. If wall-mounted ON/OFF control is to be used, mount it in a convenient location on a wall near the fireplace.
8. If an optional control is to be used, wire it in the low voltage circuit (see Figure 26 on Page 20).

Note: The supplied 15 feet of 2 conductor wire has one end of each conductor connected in parallel with the appliance mounted ON/OFF burner control switch and the other end of each conductor placed on top of the unit.

CAUTION: Do Not connect the optional wall switch to a 120V power supply.

9. If an optional control switch is installed, turn the appliance-mounted ON/OFF burner control switch to the OFF position.
10. After the wiring is complete, replace the cover plate.

Wiring - Power Vent Termination

Alternate Instructions (For use when access to the termination is easy and a secondary electrical junction box installation is not desired).

- Remove the junction box cover from the termination by removing the attaching screw (refer to Figure 22).
- Loosen the strain relief on the termination shown in Figure 22. Pull the pigtail in and shorten it to fit within the junction box cover.
- Route 14 gauge AWG grounded Romex wiring (not provided) from fireplace to the J-Box at the termination. Ensure the wiring is safety plated to prevent damage by framing nails and finish drywall screws. Route the wire into the lower control compartment and cut to length before installing the terminals. Install provided wiring hardware on the fireplace end of the Romex wire.

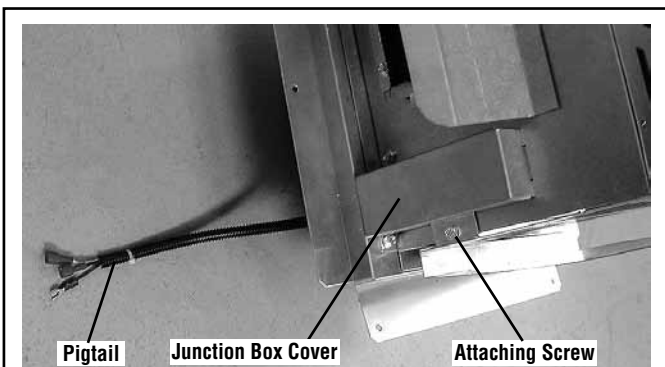

Figure 22 - Bottom Of Termination

- Refer to Figure 26 and install the electrical hardware on the fireplace end of the Romex wiring. Male terminals (#10) on the Black and White wires, and ring terminals (#9) on the ground wire. The termination end of the Romex will be connected to the termination with wire nuts (not provided).
- Refer to Figure 25 to connect the three wires of the Romex cable to the termination. Ensure the ground ring terminal is grounded beneath a structural screw as shown. Attach the junction box cover to the termination with the screw previously removed.
- The fireplace end of the Romex will be addressed in Connecting The Power Vent To The Fireplace Control System.

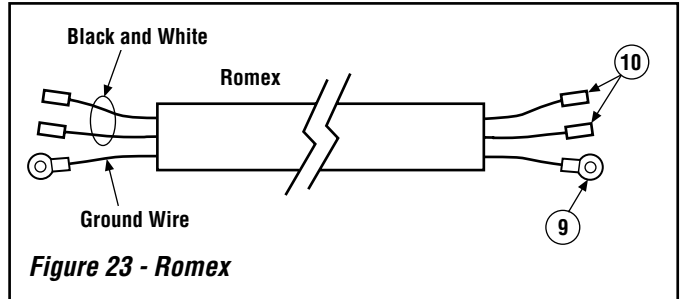

Figure 23 - Romex

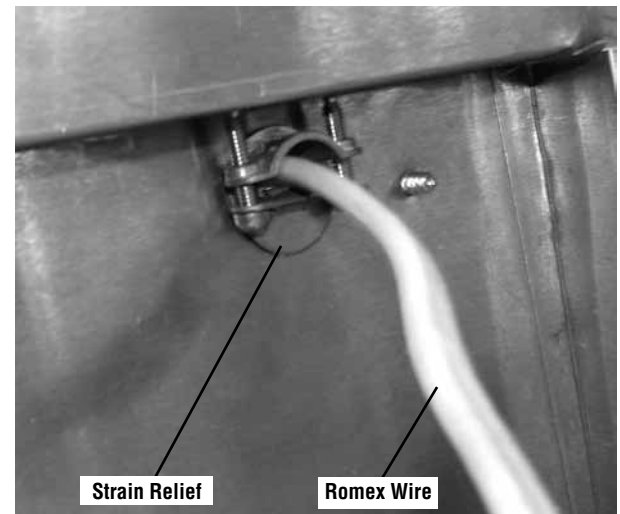

Figure 24 - Back Of Termination

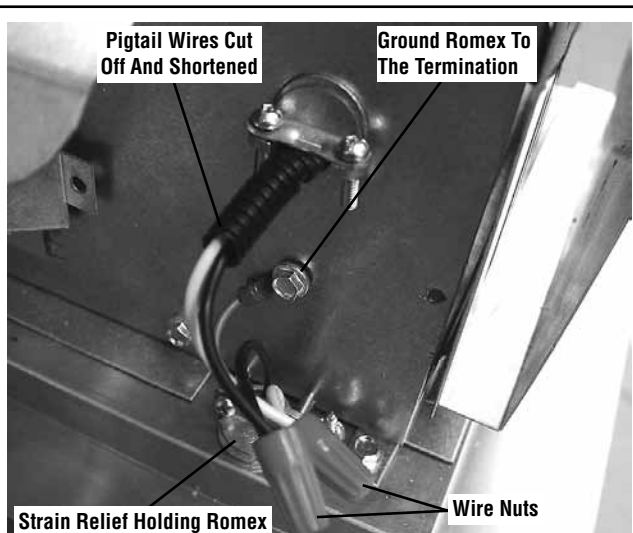

Figure 25 - Junction Box Cover Removed

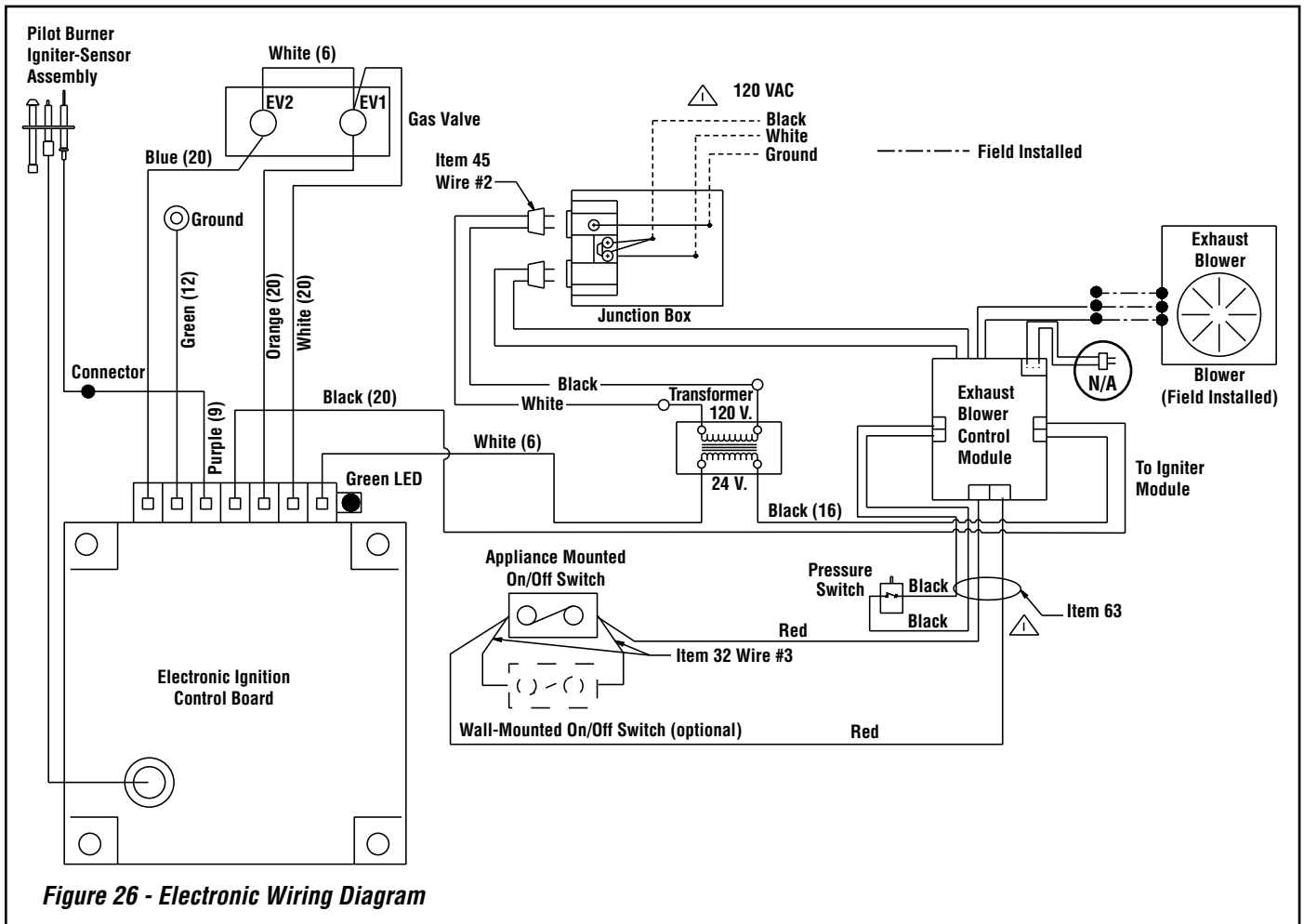

Figure 26 - Electronic Wiring Diagram

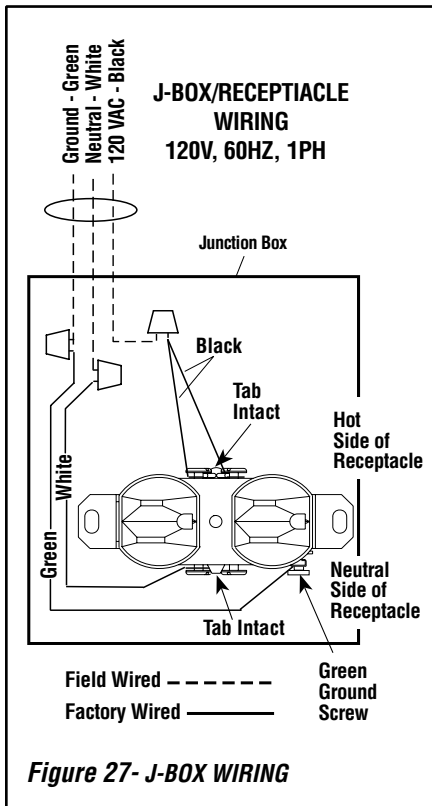

Figure 27 - J-BOX WIRING

Step 5. REMOVING GLASS DOOR ASSEMBLY

⚠ WARNING

- Handle this glass with extreme care! Glass is susceptible to damage – Do not scratch or handle roughly while reinstalling the glass door frame.
- Do not attempt to substitute the materials used on this door, or replace cracked or broken glass with any materials other than those provided by the appliance manufacturer.
- The glass door of this appliance must only be replaced as a complete unit as provided by the manufacturer. Do not attempt to replace broken, cracked or chipped glass separately.

Refer to Figure 39 on Page 24 and remove the front glass door assembly as follows:

To remove the firescreens, lift up the center of the rod to disengage it from the center bracket, bend down at center, hold left side with hand until it disengages from left side, being careful not to scratch paint. Slowly remove the rod from the right side.

Using a Phillips screwdriver, unfasten two (2) screws located at the top of the glass frame.

Tilt the glass frame at the top away from the unit. Lift it carefully off the bottom door track and set the door aside, protecting it from inadvertent damage.

Step 6. CONNECTING GAS LINE

All codes require a shut-off valve mounted in the supply line. The orientation of the shut-off valve should face the front. **Figure 29** illustrates two methods for connecting the gas supply. A Sediment Trap is recommended to prevent moisture and debris in gas line from damaging the valve.

The flex-line method is acceptable in the U.S.A where local codes permit. Installation must be in compliance with local codes. These appliances are equipped with a gas flex-line for use in connecting the unit to the gas line.

See **Figure 29** for flex-line description. The flex-line is rated for both natural and propane gas.

A manual shut off valve is also provided with the flex-line. The gas control valve is located on the right side of the unit.

When using solid gas line connector, access the valve by removing the front door assembly on the valve access side and the access plate (refer to **Figure 28**).

The electronic control valve has a 3/8" (10 mm) NPT thread gas supply inlet.

Secure all joints tightly using appropriate tools and sealing compounds (ensure propane resistant compounds are used in propane applications).

Bring the shutoff valve on the end of the flex-line over to the hard pipe and tighten with wrenches from above through the firebox opening.

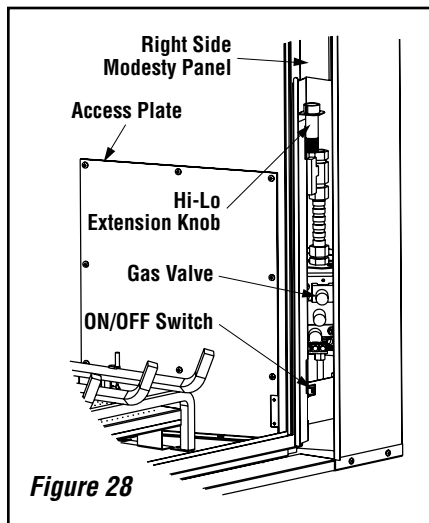

Figure 28

TEST ALL CONNECTIONS FOR GAS LEAKS (FACTORY AND FIELD):

! WARNING

Never use an open flame to check for leaks.

Turn on gas supply and test for gas leaks using a gas leak test solution (also referred to as bubble leak solution).

Note: Using a soapy water solution is an effective leak test solution but it is not recommended, because the soap residue that is left on the pipes/fittings can result in corrosion over time.

- A.** Light the appliance (refer to the lighting instructions label in control compartment or in the Care and Operation instructions manual).
- B.** Brush all joints and connections with the gas leak test solution to check for leaks.

If bubbles are formed, or gas odor is detected, turn the gas control knob (off/pilot/on) to the "OFF" position. Either tighten or refasten the leaking connection, then retest as described above.

- C.** When the gas lines are tested and leak free be sure to rinse off the leak testing solution.
- D.** Re-install the access plate, making certain the gasket has not been damaged.

Step 7. INSTALL FIREBOX LINER KIT

Install the firebox liner kit per the instructions provided in kit (ref form # 750182M).

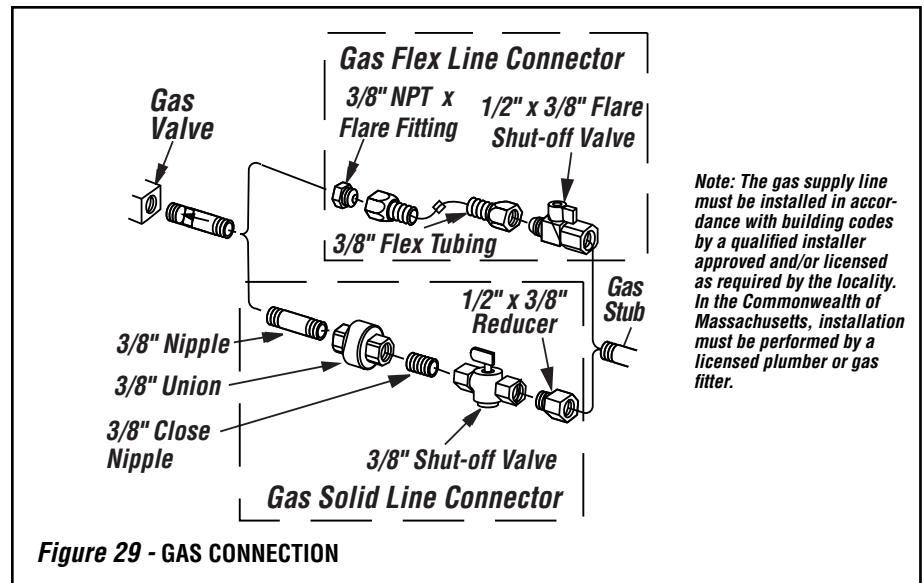

Figure 29 - GAS CONNECTION

Note: The gas supply line must be installed in accordance with building codes by a qualified installer approved and/or licensed as required by the locality. In the Commonwealth of Massachusetts, installation must be performed by a licensed plumber or gas fitter.

Step 8. VERIFYING APPLIANCE OPERATION

Turn on burner then observe the individual tongues of flame on the burner. Make sure all ports are open and producing flame evenly across the burner. If any ports are blocked, or partially blocked, clean out the ports.

With gas line installed run initial system check-out before closing up the front of the unit. Follow the pilot lighting instructions provided.

Note: Lighting Instructions are also found on the literature tag tied to the bracket above the gas valve. To access the tag, reach into the right side opening.

When first lighting the appliance, it will take a few minutes for the line to purge itself of air. Once purging is complete, the pilot and burner will light and operate as indicated in the instruction manual. Subsequent lighting of the appliance will not require such purging. Inspect the pilot flame (remove logs, if necessary, handling carefully).

Electronic Appliance Checkout

To light the burner, turn 'ON' the optional remote wall switch or turn the appliance mounted ON/OFF switch to the "ON" position. Ensure the igniter lights the pilot. The pilot flame should engulf the flame sensor as shown in **Figure 30**.

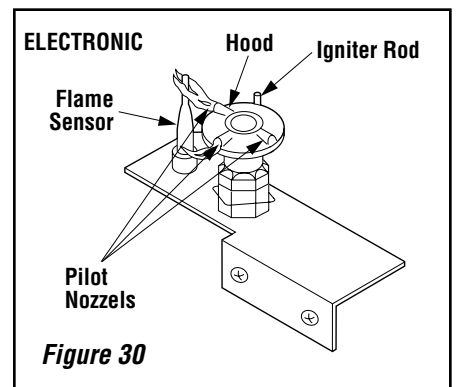

Figure 30

Step 9. INSTALL VOLCANIC STONE, GLOWING EMBERS AND LOGS

⚠ WARNING

- **DO NOT attempt to install the logs until the appliance installation has been completed, the gas line connected and tested for leaks and the initial burner operation has been checked out.**
- **The size and position of the log set was engineered to give the appliance a safe, reliable and attractive flame pattern. Any attempt to use a different log set in the fireplace will void the warranty and will result in incomplete combustion, sooting, and poor flame quality.**
- **Logs get very hot and will remain hot up to one hour after gas supply is turned off. Handle only when logs are cool. Turn off all electricity to the appliance before you install grate, volcanic stone, embers and logs.**
- **This appliance is not designed to burn wood. Any attempt to do so could cause irreparable damage to the appliance and prove hazardous to your safety.**
- **If logs are not installed according to the log installation instructions, flame impingement and improper combustion could occur and result in soot and/or excessive production of carbon monoxide (CO), a colorless, odorless, toxic gas.**

Step 1. Install the ceramic panels per the instructions provided in kit (reference form #750182M).

Step 2. Place the volcanic stone around the burner as shown in *Figure 33*.

Step 3. Separate the glowing embers (rockwool) into pieces about the size of a quarter (see *Figure 31*). Keep the pieces fluffed, not matted. Distribute these pieces over the burner as shown in *Figure 32*. Do not use more than necessary. When properly positioned, the Glowing Embers will cover approximately 75% of the burner on natural gas. For propane gas, do not place embers on main ports.

Note: Excessive use of embers may result in sooting or poor flame. This appliance is provided with enough Glowing Embers for several applications, do not feel compelled to use all that is in a new bag. For best glowing effect, replace the ember material annually. Replacement Glowing Embers are available (Catalog Number 88L53).

Step 4. Position the individual logs as shown in *Figures 34 through 38*. Logs should be placed in the order shown. **Place logs 2 and 3 against the pins on the grate, NOT over them.**

Proper log and twig placement is critical to encourage outstanding flame appearance and prevent sooting. When positioned properly as shown, twigs will be positioned between flame peaks and will not impinge any flames. Positioning is the same for all colors of log sets.

REFERENCE - Firebox Accessories / Parts		
Cat. No.	Model	Description
88L53	FGE	Bag of Glowing Embers
80L42	FDVS	Bag of Volcanic Stone

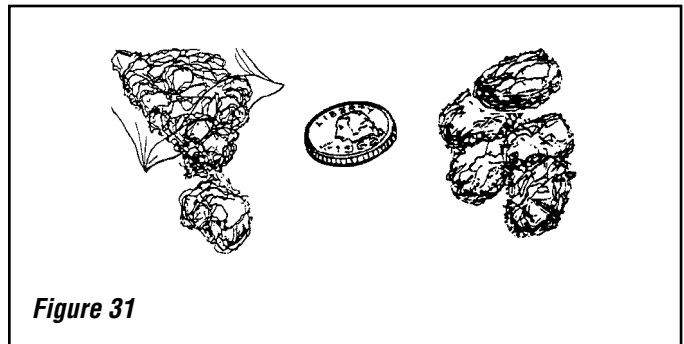

Figure 31

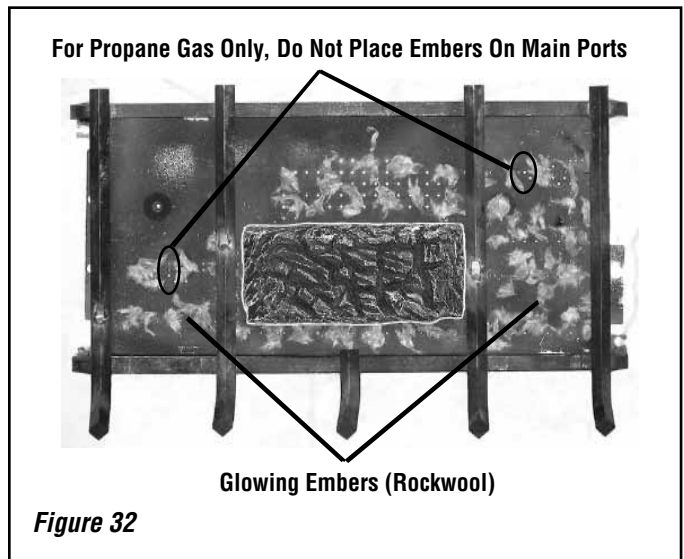

Figure 32

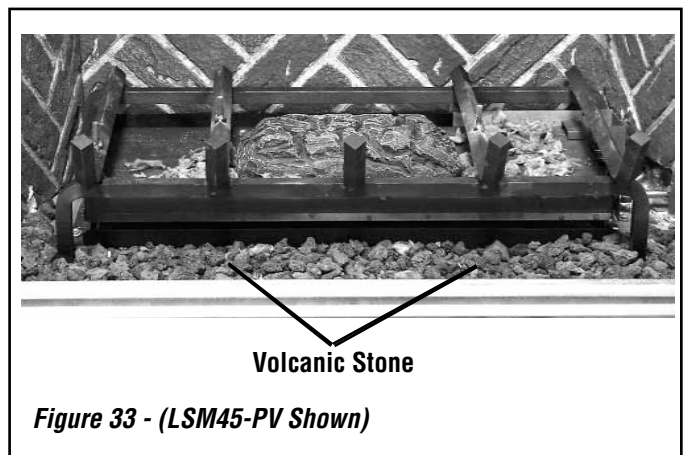
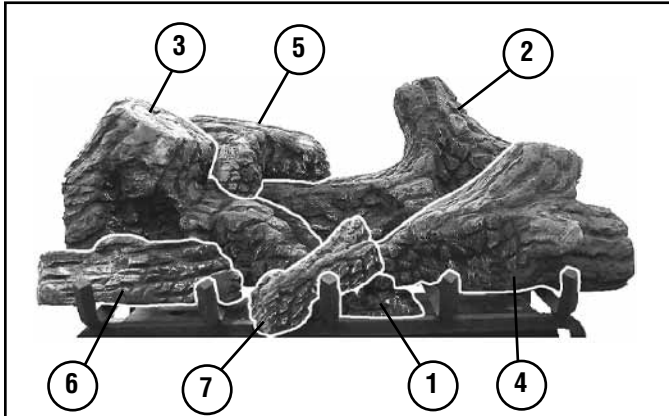

Figure 33 - (LSM45-PV Shown)

LSM40-PV and LSM45-PV Log Placement



Log Number	Description
1	Log, Center
2	Log, Rear
3	Log, Center/Left
4	Log, Center/Right
5	Log, Rear/Top
6	Log, Front/Left
7	Log, Front/Center

Figure 34

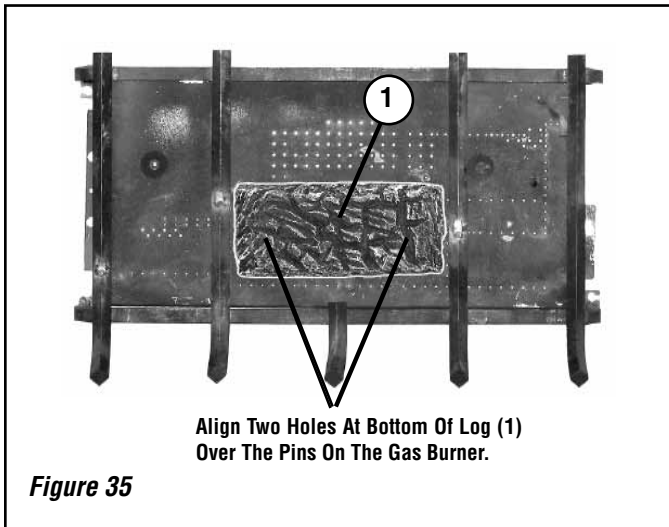

Align Two Holes At Bottom Of Log (1) Over The Pins On The Gas Burner.

Figure 35

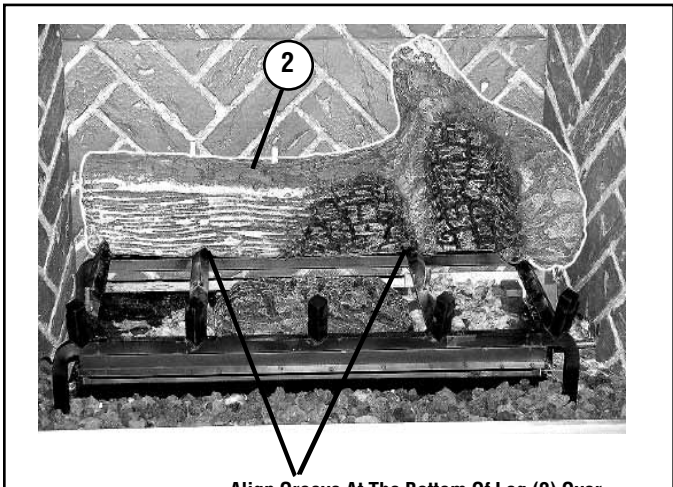

Align Groove At The Bottom Of Log (2) Over The Grate And Push It Towards The Rear.

Figure 36

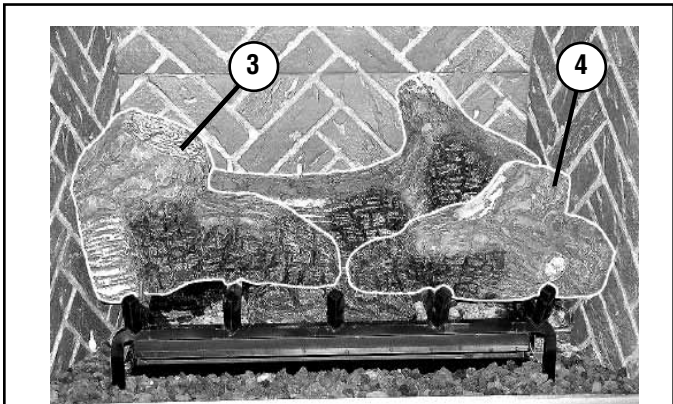

Engage Logs (3 & 4) With The Grate Pins And Align Grooves At The Bottom Of The Logs Over The Grate.

Figure 37

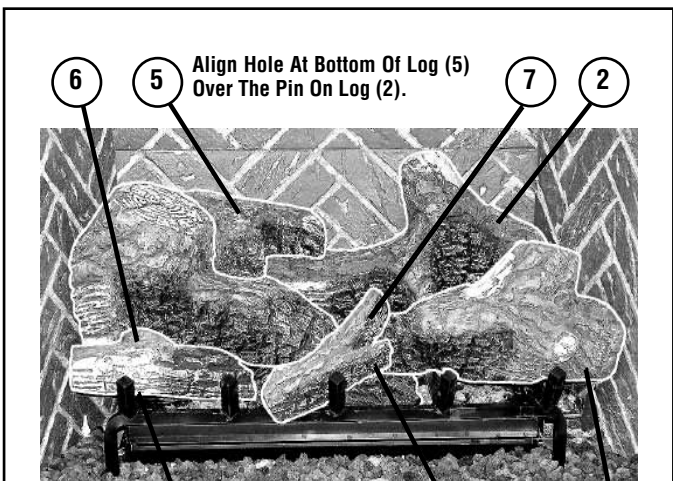

Engage Log (6) With The Grate Pin And Align Groove At The Bottom Of The Log Over The Grate.

Engage Log (7) With The Pin On Log (4).

Figure 38

Step 10. INSTALLATION AND REMOVAL OF GLASS DOOR

! WARNING

- When reinstalling the glass door, the door latch screws must be securely tightened to prevent the glass door from falling out, which could potentially cause damage and possible injury.
- Do not attempt to substitute the materials used on this door, or replace cracked or broken glass.
- Handle this glass with extreme care! Glass is susceptible to damage – Do not scratch or handle roughly while reinstalling the glass door frame.
- The glass door of this appliance must only be replaced as a complete unit as provided by the manufacturer. Do not attempt to replace broken, cracked or chipped glass separately.
- Do not attempt to touch the front enclosure glass with your hands while the fireplace is in use.

! WARNING

Do not operate appliance with the glass front removed, cracked or broken.

! AVERTISSEMENT

Ne pas utiliser l'appareil si le panneau frontal en verre n'est pas en place, est craqué ou brisé.

Only doors certified with the appliance shall be used.

Seules des portes certifiées pour cet appareil doivent être utilisées.

CAUTION: DO NOT abuse glass door by striking or slamming shut.

Retrieve the glass door. Visually inspect the gasket on the backside of the frame. Gasket surface must be clean, free of irregularities and seated firmly.

Position the door in front of the firebox opening with the top of the door held away from the fireplace (*Figure 39*). Lower the bottom of the door assembly on the bottom door track and set on padded surface. Pivot the door up after engaging and centering in the base channel.

Using a Phillips screwdriver, fasten the door frame to the door latch with the two (2) screws. The latch should pull forward to engage the door frame.

Install the door modesty shield on top flange glass door as follows: grab the door modesty shield with both hands, with the open hem going down and engage it with the upper lip of the glass door frame by pushing it all the way down. Make sure the installed shield is firmly in place.

With the firescreen hanging on the screen rod, insert the right side of the rod into the existing hole on the right modesty panel. Bend down the rod at the center and drop the left end into the slot on the left modesty panel, being careful not to scratch the paint.

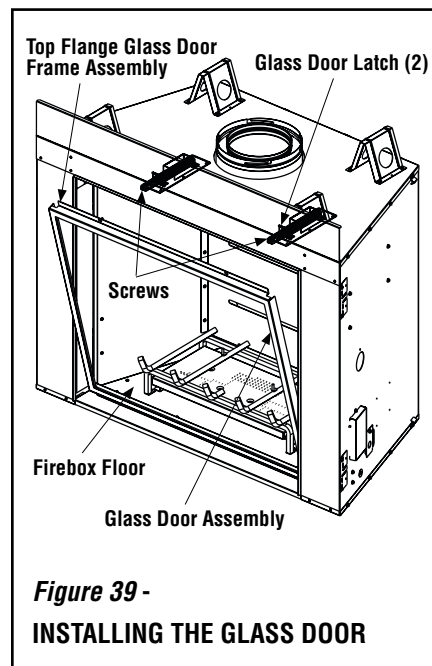

**Figure 39 -
INSTALLING THE GLASS DOOR**

Step 11. BURNER ADJUSTMENTS

Flame Appearance and sooting

Proper flame appearance is a flame which is blue at the base and becomes yellowish-orange in the body of the flame.

When the appliance is first lit, the entire flame may be blue and will gradually turn yellowish-orange during the first 15 minutes of operation. After 15 minutes of operation, if the flame is blue, or if the flame is orange with evidence of sooting (black tip), the air shutter opening may need to be adjusted.

If the air shutter opening is closed too far, sooting may develop. Sooting is indicated by black puffs developing at the tips of very long orange flames. Sooting results in black deposits forming on the logs, appliance inside surfaces and on exterior surfaces adjacent to the vent termination.

Sooting is caused by incomplete combustion in the flames and lack of combustion air entering the air shutter opening. To achieve a warm yellowish-orange flame with an orange body that does not soot, the shutter opening must be adjusted between these two extremes.

Air Shutter Adjustment Guidelines

- If there is smoke or soot present, first check the log set positioning to ensure that the flames are not impinging on any of the logs. If the log set is properly positioned and a sooting condition still exists, then the air shutter opening should be increased.
- The more offsets in the vent system, the larger the air shutter opening will need to be.
- An appliance operated with the air shutter opened too far, may have flames that appear blue and transparent. These weak, blue and transparent flames are termed anemic.
- Units converted for use with Propane gas may exhibit flames which candle or appear stringy. If this is present and persists, adjust the air shutter to a more closed position, then operate the appliance for a few more minutes to ensure that the flame normalizes and the flames do not appear sooty.

The following chart is provided to aid you in achieving the correct air shutter adjustment for your installation.

Air Shutter Adjustment Guidelines:		
Amount of Primary Air	Flame Color	Air Shutter Adjustment
If air shutter is closed too far →	Flame will be orange →	Air shutter gap should be increased
If air shutter is open too far →	Flame will be blue →	Air shutter gap should be decreased

Burner Air Shutter Adjustment Procedure

WARNING

- Air shutter adjustment should only be performed by a qualified professional service technician.
- Ensure that the front glass door assembly is in place and sealed After adjustment.

CAUTIONS

- Soot will be produced if the air shutter is closed too much. Any damage due to carboning resulting from improperly setting the air shutter is not covered under the warranty.

To adjust the flame, rotate the air shutter toward the back or toward the front of the fireplace. Position the air shutter to the factory setting as shown in the table in **Figure 40**. Allow the burner to operate for at least 15 minutes. Observe the flame continuously. If it appears weak or sooty as previously described, adjust the air shutter until the flame appearance is as desired.

Use the extension knob (refer to **Figure 28 on Page 21**), to adjust the flame height as desired, by sliding the knob over the variable flame adjustment knob located on the front of the valve. Replace the extension knob back to the hanger after the adjustment.

Units converted for use with propane gas may exhibit a flame pattern that may candle or appear stringy. If this is problematic or persists as the appliance is continually operated, adjust the air shutter open as described in the previous paragraphs. Operate the appliance for a period of time as the effect diminishes, ensuring that the appliance does not develop sooty flames. When satisfied that the appliance operates properly, proceed to finish the installation.

Leave the control knob in the ON position and the remote switch OFF.

Note: See **Figures 41 and 42** for proper burner flame appearance.

Main Burner Factory Air Shutter Opening Setting - Inches (millimeter)		
Model	Natural Gas	Propane Gas
LSM40-PV	1/8 (3.18)	1/4 (6.35)
LSM45-PV	1/8 (3.18)	1/4 (6.35)

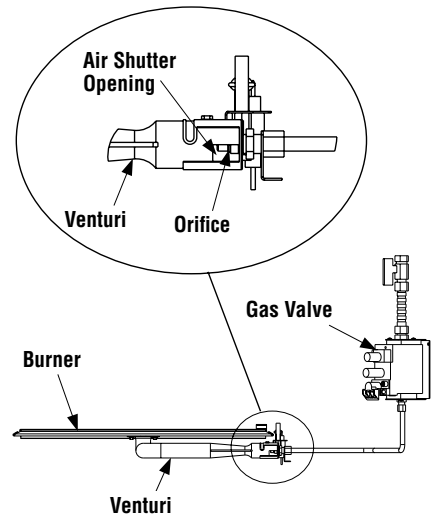

Figure 40



Figure 41 - Burner Flame Appearance

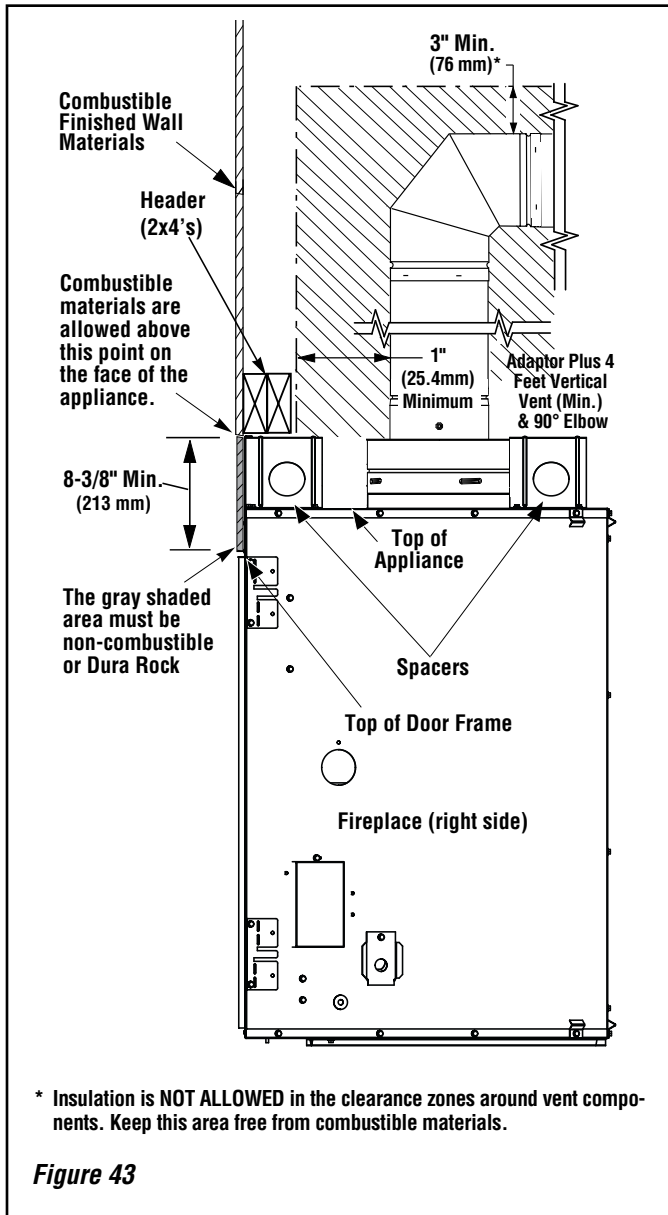

Figure 42 - Burner Flame Appearance

FINISHING REQUIREMENTS

Wall Details

Complete finished interior wall. To install the appliance facing flush with the finished wall, position framework to accommodate the thickness of the finished wall (*Figure 43*).



A hearth extension is not required with this appliance. If a hearth extension is used, there are two methods of installation. One, the finish combustible or non-combustible material could be ended by butting up against the front face of the fireplace and the floor panel (*refer to Figure 44*).

Two, the finish combustible or non-combustible material could be ended below the fireplace (*refer to Figure 45*). Remove the floor panel as shown in *Figure 44* by removing the screws on the right side of the panel and sliding the left side away from the tab. Discard the screws and floor panel. **It is critical that there is at least a 1/8" gap between the bottom of the door track and the surface of the finish material.**

Non-combustible materials, such as surrounds and other appliance trim, may be installed on the appliance front face with the exceptions.

Vertical installation clearances to combustible mantels vary according to the depth of the mantel (see *Figure 5 on Page 8*). Mantels constructed of non-combustible materials may be installed at any height above the appliance opening.

Combustible materials may project beyond the side of the fireplace opening as long as it is kept within the shaded area illustrated in *Figure 6 on Page 8*.

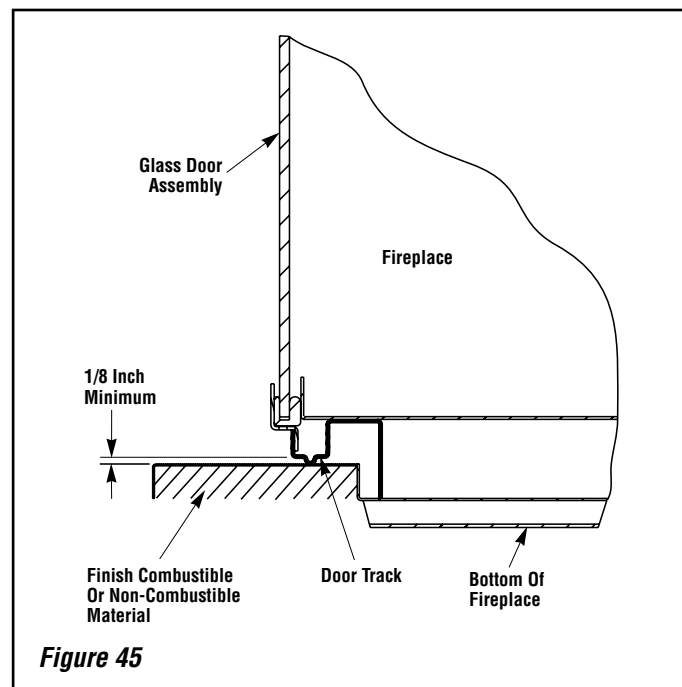
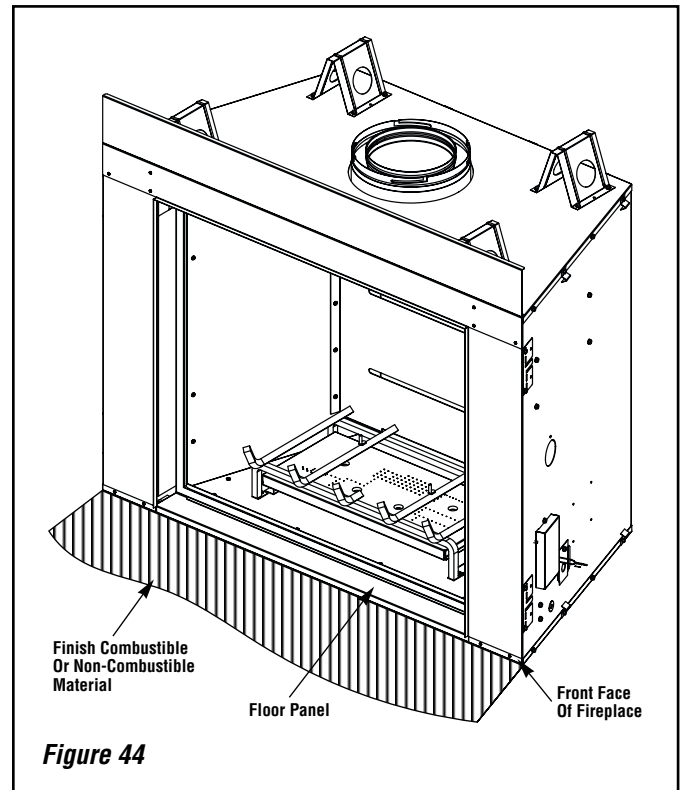

Step 12. ATTACHING SAFETY-IN-OPERATION WARNINGS

It is the installers responsibility to ensure these warnings are properly affixed during installation. These warning labels are a critical step in informing consumers of safe operation of this appliance.

ATTACHING SAFETY-IN-OPERATION WARNINGS

It is required that the safety instruction labels furnished with the fireplace be affixed to the operation and control point of the fireplace. A safety instruction label must be affixed to the wall switch plate where the fireplace is turned on and off (See **Figure A**) or wall thermostat (See **Figure B**) and if used on the remote control handheld transmitter (**Figure C**). To properly complete the installation of this fireplace, locate the multi-lingual adhesive labels provided with the Care and Operation Instructions and proceed as follows:

1. Locate the wall switch or wall thermostat that controls the fireplace (verify the switch operates the fireplace by turning it on and off). Clean the wall switch plate or wall thermostat thoroughly to remove any dust and oils. Affix the label to the surface of the plate of the wall switch that controls the fireplace (**Figure A**) or the wall thermostat (**Figure B**). Choose the language primarily spoken in the home. If unknown, affix the English language label.
2. If a remote control is used to control the fireplace, locate the transmitter and clean it thoroughly to remove any dust and oils. Affix the label to the surface of handheld transmitter (**Figure C**). Choose the language primarily spoken in the home. If unknown, affix the English language label.
3. If you are unable to locate the labels, please call Lennox Hearth Products or your nearest Lennox Hearth Products dealer to receive additional safety instruction labels free of charge.

Cat. No. H8024 Replacement Label Kit

LENNOX HEARTH PRODUCTS
1-800-9-LENNOX

Note: English is red text on clear label. French and Spanish are white text on black label.

APPOSITION DES MISES EN GARDE RELATIVES À LA SÉCURITÉ D'UTILISATION

Il est impératif que les étiquettes de sécurité fournies avec le foyer soient collées à côté des dispositifs de contrôle du foyer. Une étiquette de sécurité doit être collée sur la plaque de l'interrupteur contrôlant l'allumage du foyer (voir **Figure A**) ou sur le thermostat mural (voir **Figure B**) et, le cas échéant, sur le boîtier de la télécommande (**Figure C**). Pour achever l'installation correcte de ce foyer, procédez comme suit avec les étiquettes adhésives en langues étrangères fournies avec les instructions d'utilisation et d'entretien :

1. Repérez l'interrupteur ou le thermostat mural qui contrôle le foyer (vérifiez que l'interrupteur contrôle le fonctionnement du foyer en le faisant basculer de Marche à Arrêt, et vice-versa). Nettoyez soigneusement la plaque murale de l'interrupteur ou le thermostat mural pour éliminer la poussière et les traces de graisse ou d'huile. Collez l'étiquette sur la surface de la plaque de l'interrupteur mural qui contrôle le foyer (**Figure A**) ou du thermostat mural (**Figure B**). Choisissez la langue qui est principalement parlée dans la résidence du propriétaire. En cas de doute, collez l'étiquette en anglais.
2. Si une télécommande est utilisée pour contrôler le foyer, nettoyez la soigneusement pour éliminer la poussière et les traces de graisse ou d'huile. Collez l'étiquette sur le boîtier de la télécommande (**Figure C**). Choisissez la langue qui est principalement parlée dans la résidence du propriétaire. En cas de doute, collez l'étiquette en anglais.
3. Si vous ne trouvez pas les étiquettes, veuillez appeler Lennox Hearth Products ou votre distributeur Lennox Hearth Products local pour recevoir gratuitement des étiquettes supplémentaires.

Étiquettes de remplacement, n° cat. H8024

LENNOX HEARTH PRODUCTS
1-800-9-LENNOX

Remarque : Le texte anglais est rouge sur un support transparent. Le texte français et espagnol est blanc sur un support noir.

COLOCACIÓN DE ADVERTENCIAS DE SEGURIDAD EN OPERACIÓN

Se requiere que las etiquetas de instrucciones de seguridad incluidas con la chimenea se coloquen en el punto de operación y control de la misma. Se debe colocar una etiqueta de instrucciones de seguridad en la placa del interruptor de pared desde el cual se enciende y se apaga la chimenea (ver la **Figura A**) o en el termostato de pared (ver la **Figura B**) y en el transmisor de control remoto (**Figura C**) si se usa. Para completar correctamente la instalación de esta chimenea, encuentre las etiquetas adhesivas multilingües incluidas con las instrucciones de cuidado y operación y haga lo siguiente:

1. Identifique el interruptor o el termostato de pared que controla la chimenea (verifique que el interruptor opera la chimenea encendiéndola y apagándola). Limpie bien la placa del interruptor o el termostato de pared para quitar el polvo y aceite. Pegue la etiqueta en la superficie de la placa del interruptor que controla la chimenea (**Figura A**) o en el termostato de pared (**Figura B**). Seleccione el idioma que más se habla en la casa. Si no sabe cuál es, use la etiqueta en inglés.
2. Si se usa un control remoto para controlar la chimenea, encuentre el transmisor y límpielo bien para quitar el polvo y aceite. Pegue la etiqueta en la superficie del transmisor (**Figura C**). Seleccione el idioma que más se habla en la casa. Si no sabe cuál es, use la etiqueta en inglés.
3. Si no puede encontrar las etiquetas, sírvase llamar a Lennox Hearth Products o al distribuidor de Lennox Hearth Products más cercano para recibir etiquetas de instrucciones de seguridad adicionales gratuitas.

Juego de etiquetas de repuesto - N° de cat. H8024

LENNOX HEARTH PRODUCTS
1-800-9-LENNOX

Nota: La etiqueta en inglés es transparente con texto rojo. Las etiquetas en francés y español son negras con texto blanco.

SAFETY LABEL DIAGRAMS



Figure A

DIAGRAMMES DES ÉTIQUETTES DE SÉCURITÉ

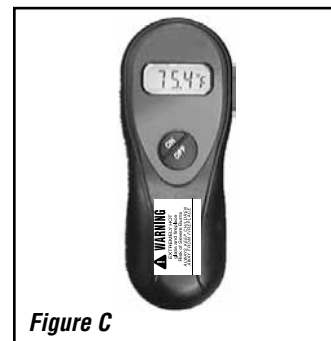
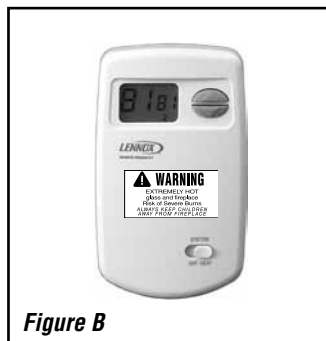
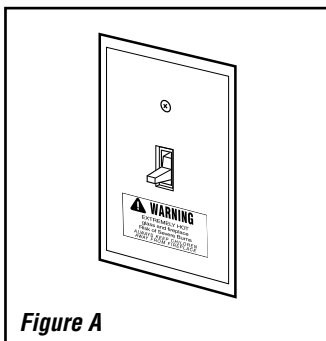

Figure B

DIAGRAMAS DE ETIQUETAS DE SEGURIDAD

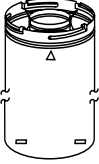
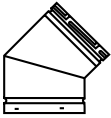
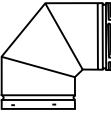

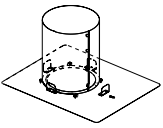
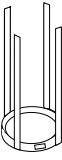
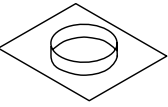



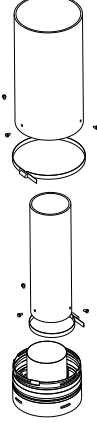
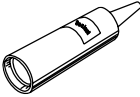

Figure C



NOTE: DIAGRAMS & ILLUSTRATIONS ARE NOT TO SCALE.

INSTALLATION ACCESSORIES

Listed Secure Vent™ Components			
	Cat. No.	Model No.	Description
	77L70	SV4.5L6	6 inch (152mm) Vent Section
	77L71	SV4.5L12	12 inch (305mm) Vent Section
	77L72	SV4.5L24	24 inch (610mm) Vent Section
	77L73	SV4.5L36	36 inch (914mm) Vent Section
	77L74	SV4.5L48	48 inch (1219mm) Vent Section
	77L75	SV4.5LA	Telescopic Section
	77L76	SV4.5E45	45 Degree Elbow
	77L77	SV4.5E90	90 Degree Elbow
	H2246	SV4.5HF	Firestop/Spacer - Horizontal (3 - 1 - 1 spacing) 10 pack
	H2247	SV4.5VF	Firestop/Spacer - Vertical (1 - 1 - 1 spacing) 10 pack
The following flashings come packaged with a storm collar:			
	H5816	SV4.5-TWSK	Through Wall Shield Kit (used to shield the direct-vent pipe from blown insulation) Ref. instr. # 750,247M
	96K93	SV4.5SU	Support Strap
	96K92	SV4.5SP	Support Plate

Listed Secure Vent / Secure Flex™ Components			
	Cat. No.	Model No.	Description
	H3907	SV4.5RSA	Attic Insulation Shield (adjustable 12" to 22")
	H7748	FVK36	36" Flex Vent Kit <i>Note: Flex attaches to appliance collar at one end and to rigid venting at the other end.</i>
	10K81	SFMP	Mill-Pac, Black, High Temperature Sealant
	89L40	SFMP-12	Mill-Pac, Black, High Temperature Sealant - Bulk 12 pack
	91L66	SF-GC4-6	Gear Clamp 4.5 in. (114 mm) for flex (6 pieces)
	91L67	SF-GC7-6	Gear Clamp 7.5 in. (190.5 mm) for flex (6 pieces)

GAS CONVERSION KITS

⚠ WARNING

This conversion kit shall be installed by a qualified service agency in accordance with the manufacturer's instructions and all applicable codes and requirements of the authority having jurisdiction. If the information in these instruction is not followed exactly, a fire, explosion or production of carbon monoxide may result causing property damage, personal injury or loss of life. The qualified service agency is responsible for the proper installation of this kit. The installation is not proper and complete until the operation of the converted appliance is checked as specified in the manufacturer's instructions supplied with the kit. The qualified service agency performing this installation assumes responsibility for this conversion.

⚠ AVERTISSEMENT

Cette trousse de conversion doit être installée par un technicien agréé, selon les instructions du fabricant et selon toutes les exigences et tous les codes pertinents de l'autorité compétente. Assurez-vous de bien suivre les instructions dans cette notice pour réduire au minimum le risque d'incendie, d'explosion ou la production de monoxyde de carbone pouvant causer des dommages matériels, des blessures ou la mort. Le technicien agréé est responsable de l'installation de cette trousse. L'installation n'est pas adéquate ni complète tant que le bon fonctionnement de l'appareil converti n'a pas été vérifié selon les instructions du fabricant fournies avec la trousse. Le fournisseur de service qualifié ayant réalisé l'installation assume les responsabilités liées à la conversion.

Gas conversion kits are available to adapt your appliance from the use of one type of gas to the use of another. These kits contain all the necessary components needed to complete the task including labeling that must be affixed to ensure safe operation.

Kit part numbers are listed here and the following steps detail the conversion procedure. Refer to the instructions provided with the conversion kit when performing any gas conversion.

<i>Electronic SIT Systems Natural Gas To Propane Gas Conversion Kit (Electronic)</i>	
Model No.	Cat. No.
LSM40-PV	H7934
LSM45-PV	H7934

INSTALLATION INSTRUCTIONS

Step 1. TURN OFF THE GAS SUPPLY TO THE APPLIANCE and disconnect power supply at the circuit breaker. Ensure appliance is cold.

CAUTION THE GAS SUPPLY SHALL BE SHUT OFF PRIOR TO DISCONNECTING THE ELECTRICAL POWER, BEFORE PROCEEDING WITH THE CONVERSION.

ATTENTION. AVANT D'EFFECTUER LA CONVERSION, COUPEZ D'ABORD L'ALIMENTATION EN GAZ, ENSUITE, COUPEZ L'ALIMENTATION ÉLECTRIQUE.

Step 2. Remove the front glass door/frame and the access plate from the appliance. See *Figure 39*.

Step 3. Carefully remove the logs and the grate assembly. **Exercise care so as not to break the logs.**

Step 4. Refer to *Figure 46*. Remove the burner assembly with attached venturi tube.

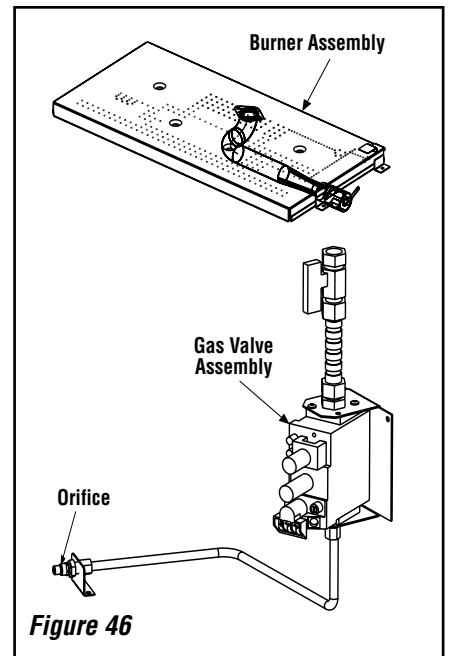

Figure 46

Step 5. Refer to *Figure 47 on Page 30* and the instructions provided with the kit. Using a Torx T20 (with 1/4" shank and center hole), remove and discard the three pressure regulator mounting screws. Remove the pressure regulator, spring, poppet, diaphragm and bushing. **Discard all removed components.**

Ensure the rubber gasket installed on the back of the replacement pressure regulator is properly positioned and install the new pressure regulator using the new screws supplied with the kit. Tighten screws to 25 In. lb. torque.

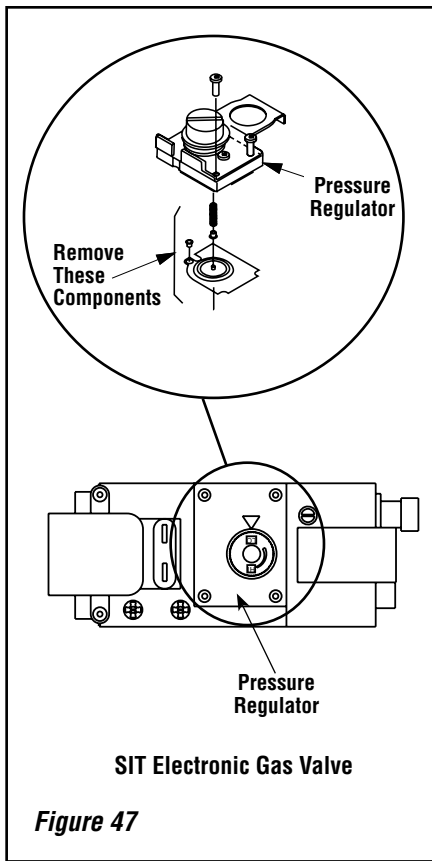

Figure 47

Step 6. Refer to **Figure 48** and remove the pilot hood assembly to access the hexed pilot orifice. Remove and replace the orifice with the one provided with the kit.

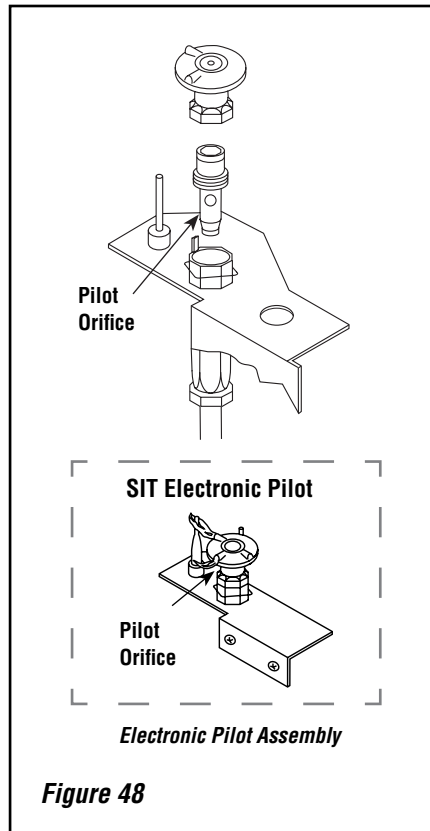

Figure 48

Step 7. (Refer to **Figure 46** on **Page 29** and **Figure 49**)

VERIFY THE PROPER ORIFICE SIZE BEFORE INSTALLING IT.

- A.** Remove the orifice from the manifold and replace it with the one provided in the kit. See the following table for orifice sizes for natural and propane models. **Figure 49** illustrates the orifice. Use pipe joint compound or Teflon tape on all pipe fittings before installing (ensure propane resistant compounds are used in propane applications, do not use pipe joint compounds on flare fittings).
- B.** Retrieve the burner and slide the venturi tube over the orifice. Set the burner assembly into its position and secure it.
- C.** Reinstall the grate assembly.

Burner Orifice Size Elevation 0-2000 ft. (0-610m)		
Model	Natural Gas	Propane Gas
LSM40-PV	.125" (1/8") * H7924 •	.073" (#49) H7936 •
LSM45-PV	.125" (1/8") * H7924 •	.073" (#49) H7936 •

Table 9
* Standard size installed at factory
• Part /Cat. Number

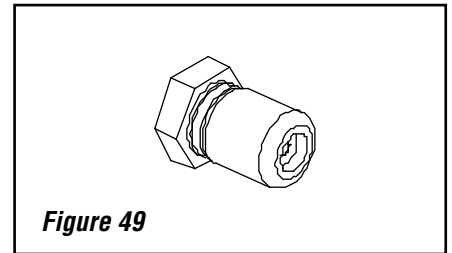

Figure 49

Step 8. Reassemble the remaining components by reversing the procedures outlined in the preceding steps.

Step 9. Attach the conversion label provided in the conversion kit to the rating plate on the appliance.

Step 10. Turn on gas supply and test for gas leaks. See *Test All Connections For Gas Leaks* on **Page 21**.

Step 11. Attach manometer to the manifold side pressure test fitting and verify manifold pressure reads 3.5 inches water column (0.87 kPa) for natural gas, and 10.0 inches water column (2.49 kPa) for propane gas.

ALWAYS TEST PRESSURES WITH THE VALVE REGULATOR CONTROL AT THE HIGHEST SETTING.

NOTES

Lennox Hearth Products reserves the right to make changes at any time, without notice, in design, materials, specifications, and prices, and also to discontinue colors, styles, and products. Consult your local distributor for fireplace code information.

