



HEARTH PRODUCTS

INSTALLATION AND OPERATION INSTRUCTIONS

VILLA VISTA™

Wood Burning Fireplaces
P/N 850,028M REV. J 11/2008

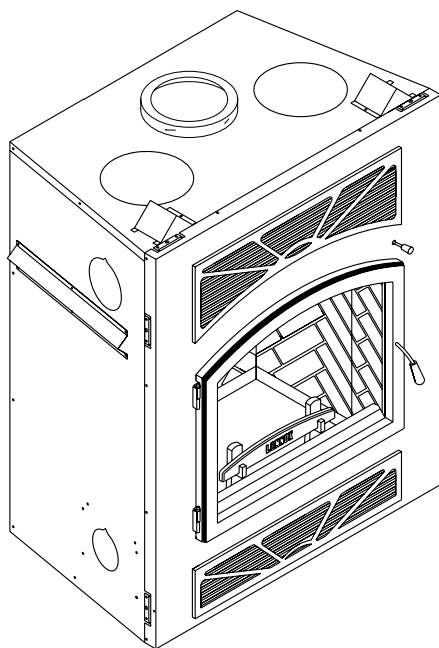

MODEL

Villa Vista

This installation manual will enable you to obtain a safe, efficient and dependable installation of your fireplace system. Please read and understand these instructions before beginning your installation.

Do not alter or modify the fireplace or its components under any circumstances. Any modification or alteration of the fireplace system, including but not limited to the fireplace, chimney components and accessories, may void the warranty, listings and approvals of this system and could result in an unsafe and potentially dangerous installation.

Lennox Hearth Products wood-burning fireplaces are designed for use as a supplemental heater. They are not intended for continuous use as a primary heat source.

SAVE THESE INSTRUCTIONS FOR FUTURE REFERENCE

	<p>! WARNINGS</p> <ul style="list-style-type: none"> Hot! Do not touch! The glass and surfaces of this appliance will be hot during operation and will retain heat for a while after shutting off the appliance. Severe burns may result. Carefully supervise children in the same room as appliance.

! WARNINGS	
<ul style="list-style-type: none"> The fireplace cannot be operated without a door. Consult your dealer to select the correct door model. Important! To assure proper alignment of glass doors: Install this fireplace in a square and plumb condition, using shims as necessary at sides and/or bottom. Install the fireplace only as described in these instructions. 	

	<p>Listed to standards: ULC-S610 & UL-127 Report No. 192-5237</p>
--	---

	<p>We recommend that our woodburning hearth products be installed and serviced by professionals who are certified in the U.S. by the National Fireplace Institute® (NFI) as NFI Woodburning Specialists or who are certified in Canada by Wood Energy Technical Training (WETT).</p>

IMPORTANT! GENERAL SAFETY PRECAUTIONS. READ AND UNDERSTAND THESE SAFETY RULES BEFORE YOUR FIRST FIRE.

⚠ WARNING

The Villa Vista™ fireplace must be installed with an outside air kit intake, which is included with the fireplace

⚠ WARNING

THE FIREPLACE MUST BE OPERATED WITH THE DOORS FULLY OPENED OR DOORS FULLY CLOSED. IF THE DOORS ARE LEFT PARTLY OPENED, GAS AND FLAME MAY BE DRAWN OUT OF THE FIREPLACE OPENING, CREATING RISKS OF BOTH FIRE AND SMOKE. IF THE UNIT IS OPERATED WITH THE DOORS FULLY OPENED, THE FIRE SCREEN MUST BE USED.

⚠ WARNING

NEVER use gasoline, gasoline-type lantern fuel, kerosene, charcoal lighter fluid, naphtha, engine oil or similar liquids to start or “freshen up” a fire in this fireplace. Keep any flammable liquids a safe distance from the fireplace at all times.

⚠ WARNING

THIS FIREPLACE HAS NOT BEEN TESTED WITH AN UNVENTED GAS OR A FIREPLACE INSERT. TO REDUCE RISK OF FIRE OR INJURY, DO NOT INSTALL AN UNVENTED GAS LOG SET OR FIREPLACE INSERT OR OTHER PRODUCTS NOT SPECIFIED FOR USE WITH THIS FIREPLACE.

⚠ WARNING

Use care when selecting window treatments for windows located near the fireplace. Avoid using combustible flowing window treatments such as curtains on nearby windows that are of sufficient length to be blown in front of an open flame when the window is opened.

Keep any combustible furniture, materials or decorative pillows at least 48" (1219 mm) from the front fireplace opening.

⚠ WARNING

Never leave your fireplace unattended while it is burning.

⚠ IMPORTANT

When burning wood, use **SOLID NATURAL DRY WELL-SEASONED WOOD ONLY**. Hardwoods are recommended (soft woods tend to burn very quickly).

- **DO NOT** burn treated wood, charcoal, coal, trash, cardboard, driftwood, woods dipped in tar, Christmas tree greens, pitch, pine tar, creosote, chemical chimney cleaners, flame colorants, polystyrene packaging, wood products with synthetic binders (i.e. plywood). Plywood, lumber and other misc. materials can produce abnormally high temperatures, sputtering and smoking fires and may contain hazardous chemicals to treat insects and fungus.
- Burning unapproved fuels can produce excessive temperatures, beyond the design capabilities of the fireplace and may produce excess sparks or may contain hazardous chemicals. Burning unapproved fuels can result in a chimney fire, a house fire, personal injury, death or loss of property.

⚠ WARNING

Never leave children unattended when there is a fire burning in the fireplace.

⚠ WARNING

To avoid the risk of damaging fireplace materials and increasing the risk of fire, do not use the fireplace to cook or warm food.

⚠ WARNING

Be careful adding wood fuel to the fire or handling fireplace tools such as shovels, tongs or pokers.

⚠ WARNING

Never modify or alter your fireplace system in any way. To do so may create a potential fire hazard and void the Limited Warranty.

⚠ WARNING

The bottom refractory can be cracked by excessive abuse such as tossing heavy logs onto the grate or gouging with fireplace tools. Exercise caution when adding wood to your fireplace.

⚠ WARNING

Neither the manufacturer nor the seller warrants “smoke free” operation nor are we responsible for inadequate system draft caused by mechanical systems, general construction conditions, inadequate chimney heights, adverse wind conditions and/or unusual environmental factors or conditions beyond our control.

⚠ WARNING

Always ensure that the air inlet to the fireplace is free from debris and any other obstructions that can block the entrance of air.

CONGRATULATIONS!

In selecting this Lennox Hearth Products wood-burning appliance you have chosen one of the finest fireplaces available. The Villa Vista™ wood fireplace is a clean burning EPA certified fireplace that is designed to provide you dependable service as well as warmth and enjoyment for many years to come.

Please carefully read and follow all of the instructions found in this manual. Please pay special attention to the safety instructions provided in this manual. This information will be useful to you now and in years to come, so keep the manual handy and refer to it as needed.

TABLE OF CONTENTS

Safety Rules.....	Page 2
The Fireplace.....	Page 3
Introduction.....	Page 3
Parts Required.....	Page 3
Additional Equipment (Optional).....	Page 3
Operating The Fireplace.....	Page 4
Fuel.....	Page 4
Catalytic Combustor.....	Page 4
Combustion Control.....	Page 4
Starting And Maintaining A Fire.....	Page 5
Refuelling For Best Performance.....	Page 5
Smoking – Causes And Troubleshooting.....	Page 6
Important Notes.....	Page 6
Maintaining Your Fireplace.....	Page 6
Creosote.....	Page 6
Chimney Maintenance.....	Page 6
Dealing With A Chimney Fire.....	Page 6
Catalytic Combustor.....	Page 6
Door Frame Care.....	Page 7
Refractory Replacement.....	Page 7
Door Installation.....	Page 8
Door Adjustment.....	Page 8
Glass Care - Replacement.....	Page 8
Glass Care - Cleaning.....	Page 8
Gasket Replacement.....	Page 8
FIREPLACE INSTALLATION.....	Page 8
Locating The Fireplace.....	Page 8
Framing, Facing And Mantel.....	Page 9
Hearth Extension Requirements.....	Page 9
Fireplace / Framing Dimensions.....	Page 10
Insulated Chase Construction.....	Page 11
Facing / Mantel.....	Page 12
HOT AIR DUCTING INSTALLATION.....	Page 13
Gravity Kit.....	Page 13
Outside Air Kit.....	Page 15
Chimney System.....	Page 16
Acbi Chimney Installation Instructions.....	Page 17
Offset Chimney Installation.....	Page 18
Angled Wall Radiation Shield.....	Page 19
Chimney Support Installation.....	Page 20
Chimney Chase And Multiple Terminations.....	Page 20
Masonry Applications.....	Page 21
Parts And Components List.....	Page 22
REPLACEMENT PARTS.....	Page 25
Clearance To Combustible.....	Page 25
Product Reference Information.....	Page 26

SAFETY RULES FOR OPERATING YOUR FIREPLACE

- Use only Lennox Hearth Products glass doors, specifically designed for the Villa Vista fireplace.
- When cleaning the fireplace, the ashes should be placed in a metal container with a tight fitting lid. The closed container of ashes should be placed on a non-combustible floor or on the ground outside the house, pending final disposal. If the ashes are disposed of by burial in soil or otherwise locally dispersed, they should be retained in the closed container until all cinders have thoroughly cooled.

CAUTION: KEEP COMBUSTIBLE MATERIALS AT LEAST 48 INCHES AWAY FROM THE FRONT OF THE FIREPLACE OPENING.

CAUTION: BURN UNTREATED WOOD ONLY. OTHER MATERIALS SUCH AS WOOD PRESERVATIVES, METAL FOILS, COAL, PLASTIC, GARBAGE, SULPHUR OR OIL MAY DAMAGE THE CATALYST.

CAUTION: DO NOT OPERATE WITHOUT THE CATALYTIC COMBUSTOR IN PLACE.

CAUTION: NEVER BURN WITH THE BY-PASS OPENED EXCEPT FOR FIRE START-UP AND WHEN RELOADING THE STOVE.

THE FIREPLACE

INTRODUCTION

The Villa Vista fireplace is an energy efficient, heat circulating, close combustion fireplace using the catalytic technology. You will receive a lifetime of comfort and enjoyment from your fireplace provided it is maintained and operated properly.

- Please read these instructions and retain this manual for future reference.
- Before beginning the fireplace installation, consult the local authorities to obtain your building permit and check your local building codes. Install the fireplace only as described in these instructions and using only Security Chimneys International components.
- This fireplace has been tested for CAN/ULC S610-M87 and ANSI/UL 127 under report number 192-5237. It has also been tested for EPA 40 C.F.R Part 60, section 60.532(b). Certificate number 518.
- The Villa Vista Fireplace is not intended for use with a gas log set. Failure to follow these instructions will void the certification and the warranty of the fireplace and may result in an unsafe installation.

Parts Required

- Fireplace model Villa Vista
- Door set (Black, Gold, Nickel)
- Louver set (Del Sol, Diamante, Luna, Fiori, Strada)
- 7" diameter chimney model ASHT+ or ACBI manufactured by Security Chimneys International only, including:
 - Chimney lengths
 - Elbows (where necessary)
 - Radiation shield, Attic radiation shield
 - Roof flashing
 - Rain cap
 - Support
- Outside air kit (included)

Additional Equipment (optional)

- Gravity venting system
- Panel for clean face option (only with gravity venting system)
- Fireplace fan kit, UZY5
- Rigid Firescreen
- ACBI Chimney Outside Air Kit (**required with ACBI chimney installation**)

OPERATING THE FIREPLACE

Fuel

The Villa Vista™ fireplace is designed to work best when fuelled with seasoned cordwood. Hardwoods are preferred to softwoods since the energy content of wood is relative to its density. Hardwoods will result in a longer burning fire and less frequent refuelling.

A moisture content of 15% to 20% (seasoned) is recommended. Excessively wet wood will be difficult to burn and will result in lower efficiency, increased creosoting and plugging of the catalytic combustor. Excessively dry wood will burn well but will also have higher emissions and shorter burning time.

Do not burn scrap or garbage, treated wood or wood such as driftwood from the ocean which has been exposed to salt or other chemicals. Salt or chemicals can corrode the firebox and can shorten the life of the catalytic combustor. Do not burn large amounts of paper, cardboard, tree branches or building construction materials. Intense firing with these materials may overheat the fireplace, causing damage to the unit, a fire or even possibly igniting a chimney fire if the chimney is creosoted.

Overheating the unit above 1000° C (1800° F) is harmful for the catalytic combustor, it can damage the catalyst coating and can cause cracking of the substrate. Looking through the upper louvers, if the top of the firebox is glowing, the unit is overheating.

First Fires

Before using the fireplace make sure to remove the plastic wrapping on the doors. Remove all remaining glue from labels with mild soap. Gold and Nickel plated doors must be cleaned and free of fingerprints.

The first 5 or 6 fires should be small fires of short duration (about 30 to 60 minutes). This will help cure the refractory bricks. Ashes that will accumulate in the ashtray will protect it from intense heat. The first fires may produce slight smoking and some odor due to drying of the paint and steel and any dust accumulated on the fireplace will burn off at this time. It may set off a smoke alarm located in the same room. For this reason the room should be well ventilated for the first few fires.

Catalytic Combustor

The Villa Vista fireplace is equipped with a catalytic combustor. Unburned by-products of the wood fire are burned at lower temperatures as they pass through the combustor resulting in less pollution, reduced creosote and higher efficiency. In order to have the catalyst working, temperatures of the flue gases entering the combustor have to be higher than 260° C (500° F). That is why the unit is equipped with a by-pass damper that allows the draft air to by-pass the catalytic combustor. Opening the by-pass damper control increases the draft allowing the unit to achieve proper operating temperatures during a cold start-up. It also provides more draft to prevent smoke spillage when the door is opened.

When the catalyst light-off conditions are achieved, the combustor will keep on going until it runs out of smoke. Note that the catalyst does not need to be glowing to be working, it can work very well at temperatures well below the 538° C (1000° F) level at which it will begin to glow. The best way to see if the catalyst is active is to take a look at what is coming out of the chimney. If the catalytic combustor is working you will see some white water vapor coming out, compared to a more brown/gray smoke when the by-pass is opened. Do not burn any chemical chimney cleaner; it can make the catalyst inactive.

Combustion Control

There is no flue damper in the Villa Vista fireplace. As is common with air tight stoves, the combustion air damper controls the air entering the firebox. This allows for a more precise control of the fire. The combustion air damper knob is located on the left of the bottom louver (*Figure 1*). It is opened when moved completely to the left. This control should be in the closed position when the fireplace is not in use. This will minimize air leakage up the chimney. **The combustion air control and the by-pass damper control must be opened before opening the door to minimize the possibility of back draft coming into the room.**

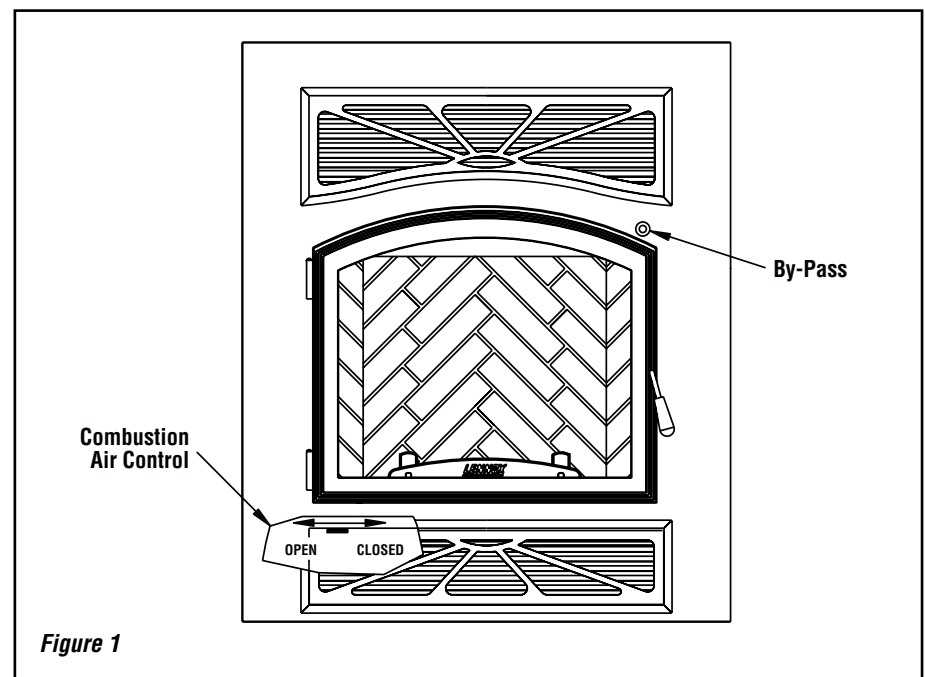

Accelerated Combustion

The maximum heat output for the Villa Vista™ fireplace is achieved by burning with the combustion air damper opened (see **Figure 2**). By this method, the Villa Vista fireplace can produce up to 70,000 BTU of heat per hour. However, it will be necessary to reload with wood every one or two hours. This is the least efficient method of burning the Villa Vista fireplace.

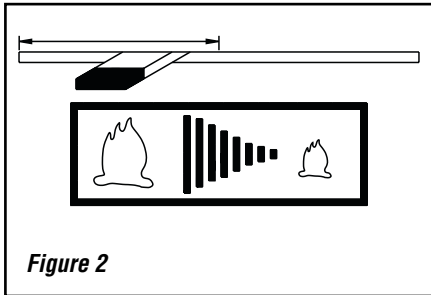

Use caution when firing with the combustion air control wide open. Only burn cordwood in this manner. Small dry pieces of softwood and construction scraps will burn very intensely using this method and may damage the firebox and catalytic combustor.

Medium Combustion

This is the recommended mode of operating the Villa Vista fireplace and should be the one normally used since it will deposit the least amount of creosote on the glass and in the chimney. The combustion air damper must be 3/4" closed (see **Figure 3**). The precise setting will depend on many factors, including chimney length and the moisture content of the wood.

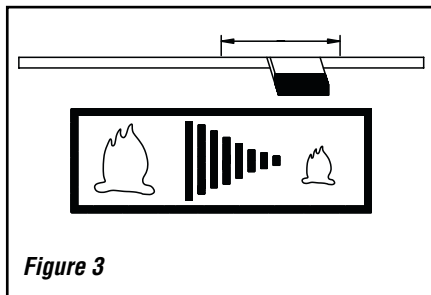

For instance, a long chimney will necessitate closing the damper more. To obtain the proper combustion, close the damper completely, then open it about 1/2 to 3/4. Three medium size pieces of wood should be burning on a bed of hot coals. The heat output will be approximately 35,000 BTU per hour and the loading time will be about every 3-4 hours. Softwoods may be burned using this method but the time will be substantially reduced.

Slow Combustion

When the air combustion damper is almost closed, the fireplace is in a slow combustion phase (see **Figure 4**). Slow combustion will not stop the fire, but there will be a noticeable change in the flame pattern. The flames will be slow and may appear dirty if the wood is too wet (moisture content of 20% and more). **Always set the damper so that flames are visible, that way you maintain a good clean combustion process.**

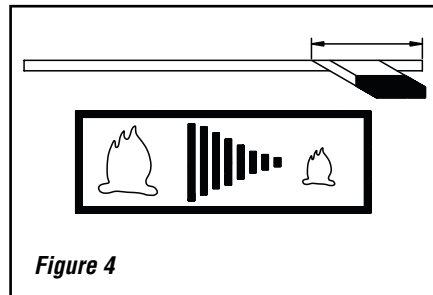

This method of burning should be used only after operating the Villa Vista fireplace with the air control opened to produce a hot fire for about an hour. Slow combustion can be used at night in order to reduce the heat output and prolong the burn. The loading time will be between 6-10 hours. **Be aware that the glass will get dirty using this setting.**

Starting And Maintaining a Fire

Step 1. Place several crumpled up balls of newspaper in the firebox. Place small dry pieces of kindling on top of the paper, criss-crossing the kindling so that there are air spaces in between. Keep the fuel far back enough so that air can get underneath.

Step 2. Open the air control fully and pull the by-pass damper control towards you to put it in the OPEN position. Light the newspaper. Leave the door open until the fire is well established.

Step 3. Once the kindling fire is well established, add increasingly larger pieces of cordwood until the fire is actively burning. Close the door and maintain an accelerated combustion air set up in order to achieve combustor light-off conditions.

Step 4. When the fire is burning well, close the by-pass damper control by pushing the control rod in. It takes about 15 – 30 minutes with the by-pass opened to reach proper light-off temperatures for the catalytic combustor.

Step 5. Set the air control at the desired setting.

The unit will burn best with 2-3 pieces of cordwood spaced 1 to 2 inches apart and allowing air to get under the fuel. Criss-crossing or arranging the fuel so that air can get underneath, will help the fire get started easily.

Refuelling for Best Performance (see **Figure 5**)

To refuel the Villa Vista fireplace at the end of a burn cycle when only hot embers remain and flames are gone (not enough heat to maintain catalyst operating temperatures):

Step 1. Open the by-pass and air controls fully.

Step 2. Open the door approximately 1 inch and wait five seconds until the draft is stable. Then open the door completely, load the fuel and close the door.

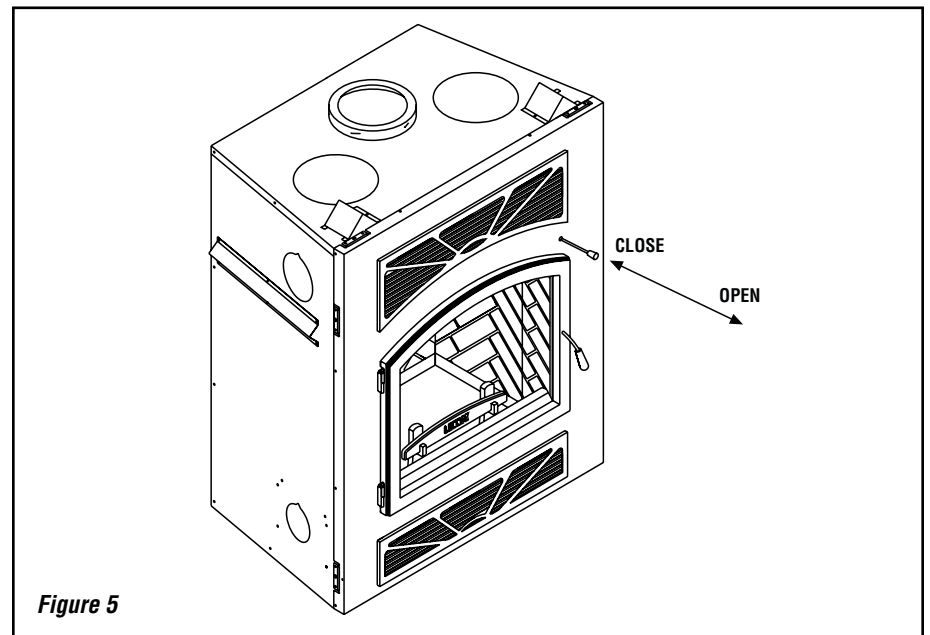

Step 3. Keep the combustion air damper and the by-pass damper opened for 10 minutes before closing it. It will ensure sufficient temperatures for combustor light-off.

To refuel the Villa Vista™ fireplace when the unit is still hot (Some burning fuel remaining or a glowing combustor)

Step 1. Open the by-pass and air controls fully.

Step 2. Open the door approximately 1 inch, wait five seconds until the draft is stable and then open it completely. Load the fuel, close the door and by-pass (temperatures within the firebox should be enough to maintain catalytic operation)

Smoking – Causes and Troubleshooting

To reduce the likelihood of smoking when opening the doors, set the air damper to the “accelerated combustion” position and open the by-pass damper before opening the doors. Your fireplace has been designed and tested to provide smoke free operation. Occasionally, there may be a small amount of smoking upon lighting the fire, until the chimney heats up but this should not continue. If the fireplace does continue to smoke, it is probably for one of the following reasons:

1. The door is partly open

Open the door fully.

2. Negative pressure in the house

As the fire burns, air goes up the chimney. This air must be replaced through leakage into the house or through the outside air duct. When operating the Villa Vista fireplace, open a nearby window temporarily to check if there is adequate air replacement.

3. Fans operating (e.g. range hood)

These fans draw air out of the house and may actually cause a negative pressure in the house. Turn off all fans and open a nearby window to determine if this is the cause of the problem.

4. Wet wood

Wet or tarred wood will smoulder and smoke instead of burn properly.

5. Dirty or blocked chimney

Check to make sure the chimney is clear and reasonably clean.

6. Chimney not long enough

The minimum chimney height is 12 feet, not including the fireplace height. The chimney must extend at least 3 feet (915 mm) above its point of contact with the roof and at least 2 feet (610 mm) higher than any roof or wall within 10 feet (3 m) of it.

7. Poor chimney draft

With no fire, there should be sufficient draft to exhaust cigarette smoke introduced under the baffle. Chimneys installed against an outside wall without protection may generate back draft problems which will cause start-up problems. To prevent this, open a nearby window, roll up a piece of paper and light it.

Then, hold it in the upper part of the firebox to warm up the chimney. Wait until the draft is sufficient, then start the fire.

Important Notes

- 1. Do not block the hot air vents of the fireplace as this will cause the fireplace to overheat.**
- 2. Never start a fire using gasoline, kerosene, charcoal lighter fluid or any other combustible liquid.**
- 3. Do not burn coal. The sulphur in coal will corrode the firebox.**
- 4. Do not burn driftwood which has been in the ocean or salt water. The salt will corrode the firebox and chimney.**
- 5. Do not operate the unit with the door partly open since this may cause smoke to be drawn into the room.**
- 6. Do not burn wood in the area in front of the log retainers.**
- 7. Do not abuse the unit by burning paper, or cardboard or construction material such as pressed wood, plywood or lumber.**
- 8. Do not allow the wood to smoulder or burn without flame, since this will produce excessive creosote in the unit.**

MAINTAINING YOUR FIREPLACE

Creosote

When wood is burned slowly, it produces tar and other organic vapors which combine with expelled moisture to form a black deposit called creosote which accumulates on the flue lining. When ignited, this creosote makes an extremely hot fire. If the creosote accumulation is large, a creosote fire in the chimney can damage the chimney and overheat the surrounding wood framing. Creosote formation in a chimney can be minimized by making small hot fires rather than slow burning, smouldering fires and by proper refuelling techniques.

Chimney Maintenance

Regular chimney inspection and maintenance combined with proper operation will prevent chimney fires. Keep your chimney clean. Do not allow more than 1/16" creosote build up in your chimney. The amount of creosote will depend on variables such as frequency of use and type of fire. We recommend that you:

1. Initially inspect the chimney system weekly. From this, you will learn how often it will be necessary to clean your chimney.
2. Have your chimney cleaned by a qualified chimney sweep. If you wish to clean it yourself, we recommend using a stiff plastic or non-metallic brush. If a metal brush is used, its size should be slightly smaller than the flue to avoid damaging the chimney. Do not use a brush that will scratch the stainless steel interior of the chimney.

3. Do not expect chemical cleaners to keep your chimney clean. The rain cap can be removed for inspection and/or cleaning of the chimney. Using gloves, firmly grip the lower portion of the rain cap. Turn the cap 1/8 of a turn counter-clockwise and lift it off the chimney.

Dealing With A Chimney Fire

Regular chimney maintenance and inspection can prevent chimney fires. If you have a chimney fire, follow these steps:

1. Close the fireplace doors and the combustion air damper.
2. Alert your family of the possible danger.
3. If you require assistance, alert your fire department.
4. If possible, use a dry chemical fire extinguisher, baking soda or sand to control the fire. Do not use water as it may cause a dangerous steam explosion.
5. Check outside to ensure that sparks and hot embers coming out of the chimney are not igniting the roof.
6. Do not use the fireplace again until your chimney and fireplace have been inspected by a qualified chimney sweep or a Fire Department Inspector.

Catalytic Combustor

The Villa Vista™ fireplace is designed with a catalytic combustor which will reduce pollution emissions and creosote build up while improving thermal efficiency. In order to optimize and maintain the combustor performance, it is important to visually check the combustor at least 3 times during the heating season to determine if physical degradation has occurred.

Catalytic combustors require little maintenance. Cleaning the combustor once a year, preferably when your flue system is serviced, is sufficient for most users.

WARNING

To prevent damage to your combustor, do not:

- **Drop the combustor (which is fragile compared to the rest of the unit – so handle with care)**
- **Run water or compressed air through the combustor**
- **Try to clean the combustor with any sharp tool**

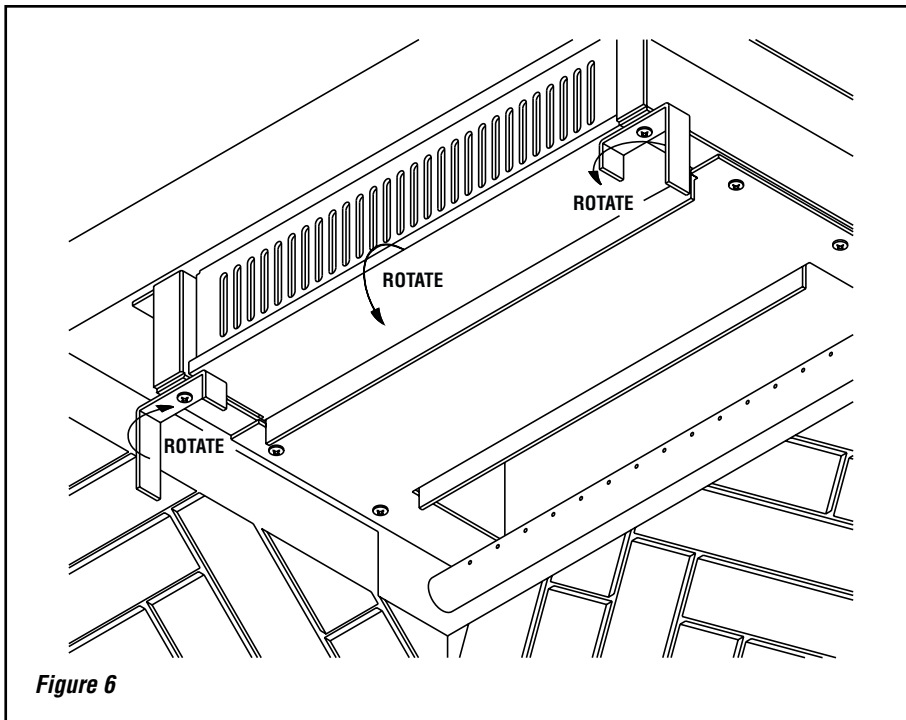

Figure 6

Cleaning Procedure (see Figure 6):

1. Rotate the retainers to release the combustor support plate while holding it to make sure it does not drop.
2. Rotate the support plate and remove the combustor.
3. Remove fly ashes on the combustor using a soft brush.
4. Put the combustor back in place.

Door Frame Care

Use a glass cleaner and a soft cloth to polish the frame. Do not use abrasives such as steel wool or steel pads for they may scratch the door frame finish.

Ashes

Remove ashes only when the fire is out and the ashes are cold (24 to 48 hours after the fire is out) Open the bottom louver and the doors, lift the door trap lever, remove the plug on the door trap of the ashtray using gloves or a poker. Sweep the ashes in the opening with a brush or any similar tool. Reinstall the plug on the door trap and pull down the lever.

Refractory Replacement

The intense heat of the fire will normally cause hairline cracks in the refractory. These cracks can be minimized by proper curing as described in "First Fires". They will not normally diminish the effectiveness of the refractory. If large cracks develop, then the refractory should be replaced. To replace the refractory bricks, follow these steps (see Figure 7):

1. Remove the front refractory
2. Remove the bottom refractory
3. Remove the left side refractory
4. Remove the right side refractory
5. Remove the back refractory

To install the new refractories, follow the above steps in reverse.

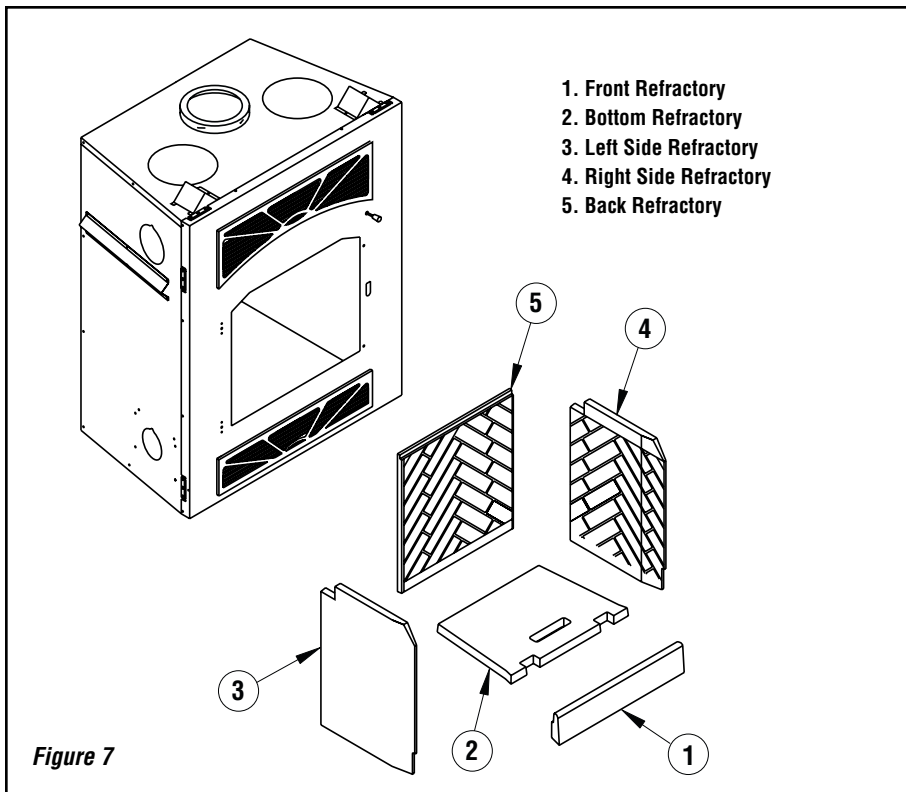

Figure 7

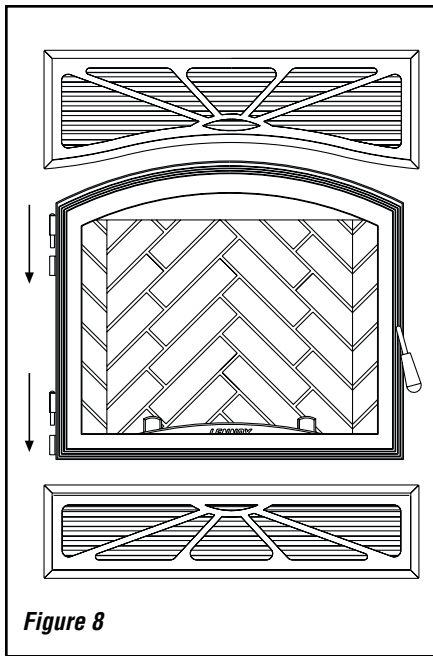

Figure 8

Door Installation

The door must be installed only when the installation of the Villa Vista™ fireplace is completed. Fit the male part of the hinge, already fixed on the door, in the female part, which is fixed on the fireplace (see **Figure 8**).

To remove the door, simply pull the door up from the hinges.

The adjustment of the door has been set at the factory. If the fit is still not perfect, you can adjust the door using the hinge screws (see **Figure 9**).

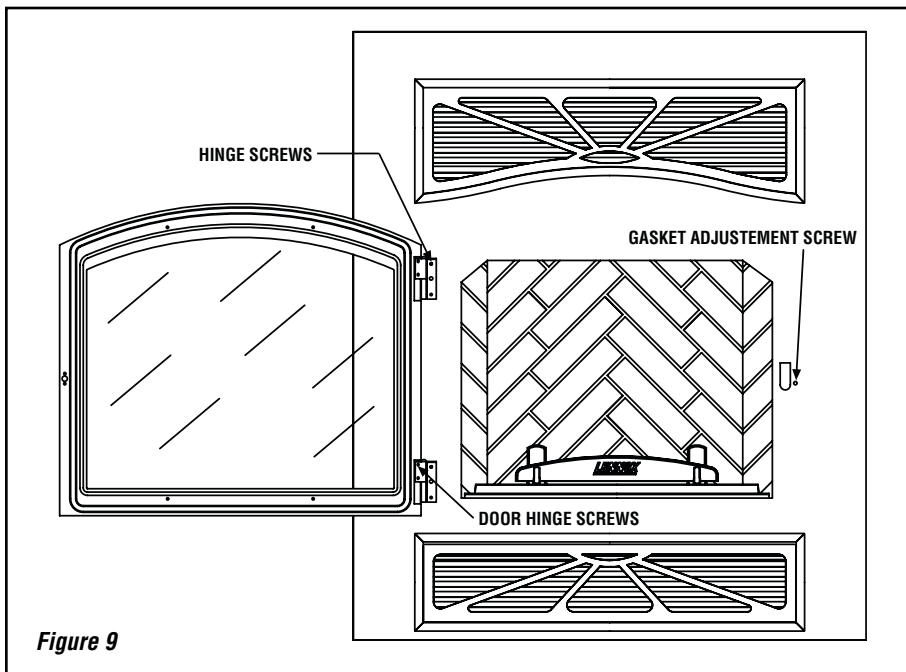

Figure 9

Door Adjustment

The door may need to be adjusted to be completely airtight. The gasket airtightness can be adjusted using the adjustment screw located on the fireplace facade at the bottom of the fireplace opening. (An Allen key # 1/8 will be necessary for adjustment). Turning the screw clockwise will increase air tightness.

Glass Care - Replacement

The glass used for the Villa Vista fireplace is a high temperature ceramic glass (1,400° F / 760° C). If the glass breaks, it must be replaced with a ceramic glass. Tempered glass or ordinary glass will not withstand the high temperatures of the Villa Vista fireplace. Replacement ceramic glass should be purchased from a LennoxHearth Products dealer. **DO NOT OPERATE THE UNIT WITH CRACKED OR BROKEN GLASS.**

Glass Care - Cleaning

The Villa Vista fireplace is designed to keep the glass clean under normal operating conditions. If the Villa Vista fireplace is operated continuously with the combustion air damper closed, the glass will tend to get dirty unless the fuel, firebox and glass are maintained at hot temperatures (see "Refuelling For Best Performance"). To clean the glass, there are a number of specially designed cleaners. Your authorised Lennox Hearth Products dealer can recommend a suitable cleaner which is available in your area. Regular household glass cleaners will not clean creosote. Do not use abrasives such as steel pads, steel wool or oven cleaner as they will scratch the glass.

DO NOT USE CHEMICAL GLASS CLEANERS ON PAINTED SURFACES AS IT MAY CAUSE THE PAINT TO PEEL.

CAUTION: DO NOT ALLOW WINDOW CLEANER TO GET IN CONTACT WITH DOOR GASKET OR PAINT ON FACADE OR DOOR. ONCE CLOSED, CONTACT OF GLASS CLEANER WITH THE FIREPLACE FACADE CAN PROVOKE PAINT PEELING OFF.

Gasket Replacement

Remove the door from the unit and lay it on a clean unabrasive surface. To replace the gasket, first remove all of the old gasket and gasket cement. Make sure that the surface is totally clean before applying new cement or adhesion problems may result. Apply gasket cement to the gasket channel and install the new gasket. This replacement part is available from your LennoxHearth Products dealer in the following dimensions:

Gasket	Length	Dimensions
Around glass	83"	5/16" dia.
On door frame	92"	5/8" dia.
Around ash trap	8"	2" wide x 1/4" thick

FIREPLACE INSTALLATION

Locating the Fireplace

1. The best place to install your fireplace is determined by considering the location of windows, doors, and the traffic flow in the room where the fireplace is to be located, allowing space in front of the unit for the hearth extension and the mantel, and taking into consideration the location of the hot air ducts (optional), outside air kit and chimney. If possible, you should choose a location where the chimney will pass through the house without cutting floor or roof joists (see fireplace dimensions on **Page 10**).

2. Usually, no additional floor support is needed for the fireplace. The adequacy of the floor can be checked by first estimating the weight of the fireplace system. Weights are given on **Page 25**. Next, measure the area occupied by the fireplace which is normally 38" X 24-1/2". Note the floor construction and consult your local building code to determine if additional support is needed.

3. A minimum of 7' (2134 mm) measured from the floor to the ceiling is required to install the Villa Vista fireplace. The fireplace can be installed on a combustible floor or on a base, leaving at least 6'8" (2032 mm) from the base of the unit to the ceiling.

Framing, Facing and Mantel

The construction of the framing, facing, and mantel must be in accordance with the standards and the following illustrations:

(see **Figures 10B, 11, 13, 14 and 15**):

1. Frame the fireplace using 2 x 3 or heavier lumber.
2. **WARNING:** Combustible materials cannot be used in the space directly above the fireplace (except for framing on the front facing). This area must remain empty for **a height of 6'8" (2032 mm) measured from the base of the appliance.**

3. Frame the fireplace with vertical studs at the sides of the fireplace running from floor to ceiling (see **Figure 10**).

If combustible facing is to be used, position the studs back, from the front edge of the fireplace, a space the thickness of the facing material so that the facing can be installed flush with the fireplace facing. Frame headers between the vertical studs only as follows:

- Place 2 x 3 or 2 x 4 headers, only along the upper part of the front, side and back faces. Do not put wood or any combustible material within the area above the fireplace except on the front facing.
- Place headers only as required to support the facing and mantel.

The fireplace cannot be in contact with the house insulation material. Cover the insulation with drywall panels or any rigid material around the fireplace.

Hearth Extension Requirements

The Villa Vista™ fireplace may be installed directly on a combustible floor. The supplied safety metal strip must be positioned as follows: One half under the front of the fireplace and the other half must extend on the floor over which the hearth extension will be built (see **Figure 10A**).

* The safety metal strip must cover the entire width of the fireplace

The combustible floor in front of the fireplace must be covered with a non-combustible material (tile, marble, stone, etc). See **Figure 10B**.

COLD CLIMATE INSTALLATIONS

Climates where temperatures will fall below 32° F (0° C).

The heating performance of the appliance will vary depending upon the level of insulation, house design, how the appliance is operated, etc.

If this fireplace is being installed in a cold climate, it is especially important to seal all cracks around the fireplace and wherever cold air could enter the room with noncombustible material.

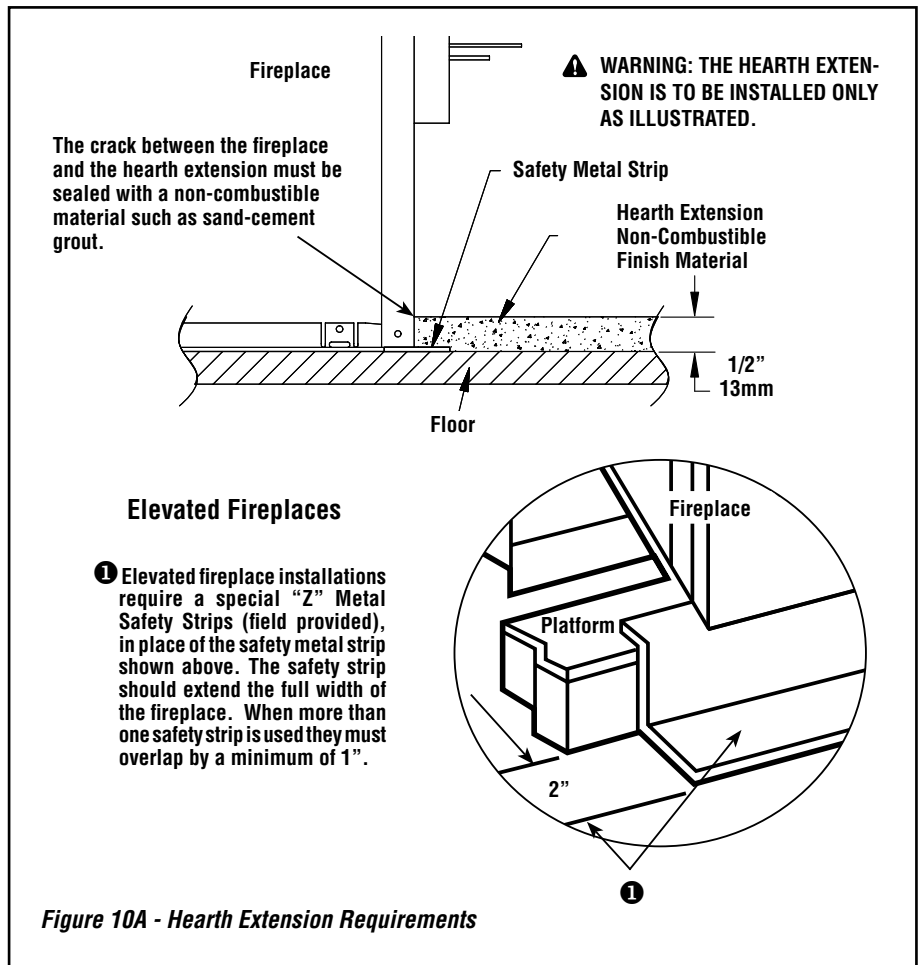

Figure 10A - Hearth Extension Requirements

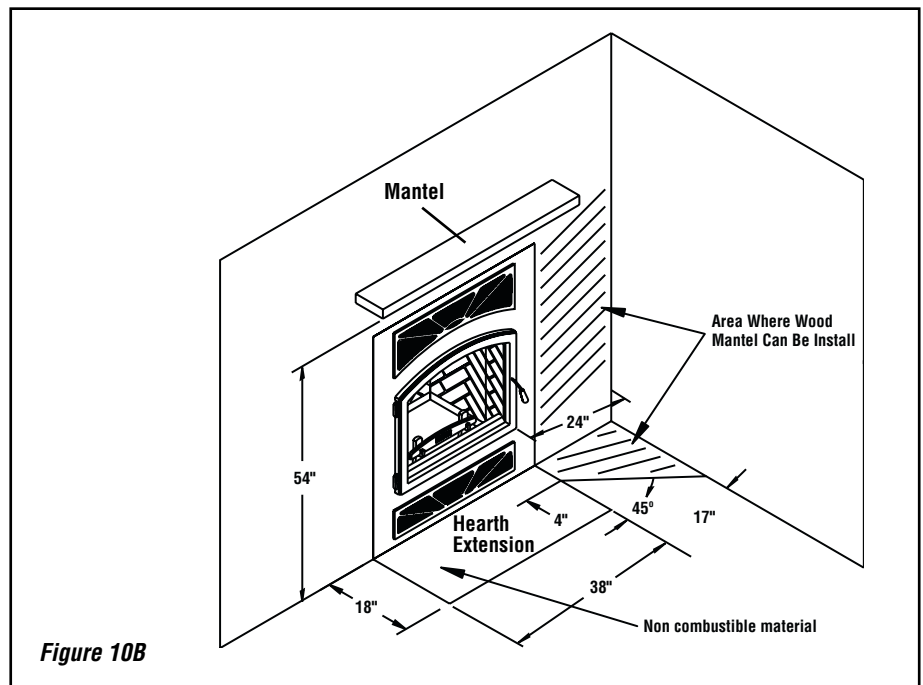
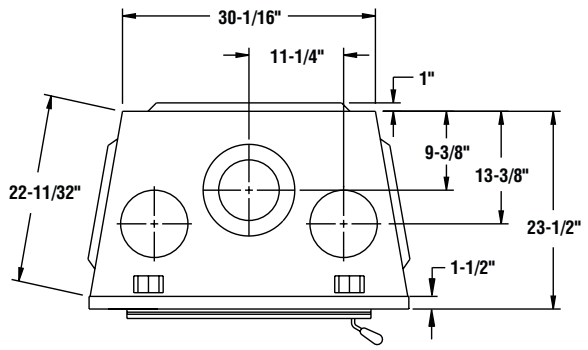
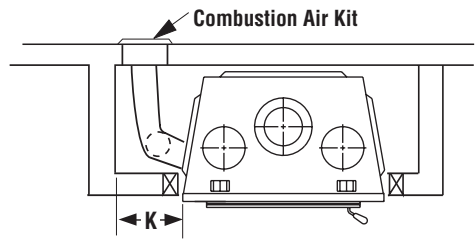
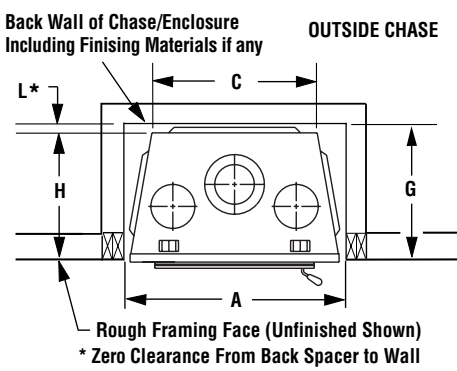
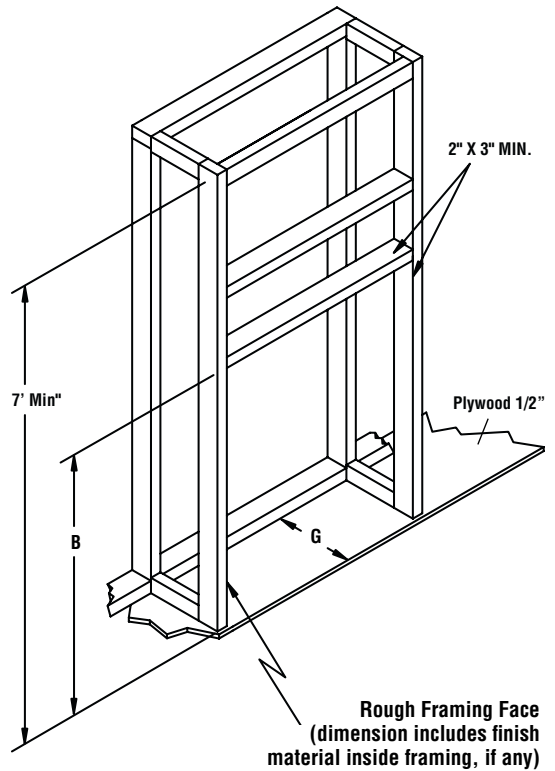
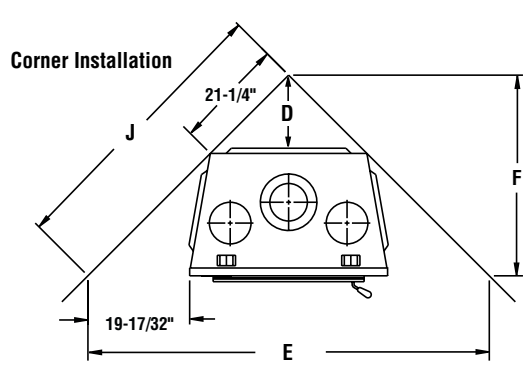

Figure 10B

Also, the outside air inlet duct should be wrapped with noncombustible insulation to minimize the formation of condensation. Do not place insulation materials directly against the chimney sections. We recommend that you use the insulated wall radiation shield since it will maintain the home's thermal barrier. AC chimney is NOT recommended in very cold climates (in areas with temperatures below 0° F (-18° C)).



FRAMING DIMENSIONS Fireplace Opening Width		
A	38-1/4"	972 mm
B	47-3/8"	1203 mm
C	30-1/16"	764 mm
D	15-1/32"	382 mm
E	77-1/16"	1957 mm
F	38-17/32"	966 mm
G	24"	610 mm
H	23"	504 mm
J	54-1/2"	1384 mm
K	8"	203 mm
L	1"	25 mm

Notes

Due to Lennox Hearth Products ongoing commitment to quality, all specifications, ratings and dimensions are subject to change without notice.

All framing dimensions calculated for 1/2" dry wall at the fireplace face. If sheathing the chase or finishing with other thickness materials, calculations will need to be made.

* The fireplace must not be in contact with any insulation or loose filling material. Cover the insulation with Drywall panels around the fireplace.

Combustible materials can NOT be used in the space directly above the fireplace. Do not fill the space above the fireplace with any material (Except the wood framing)

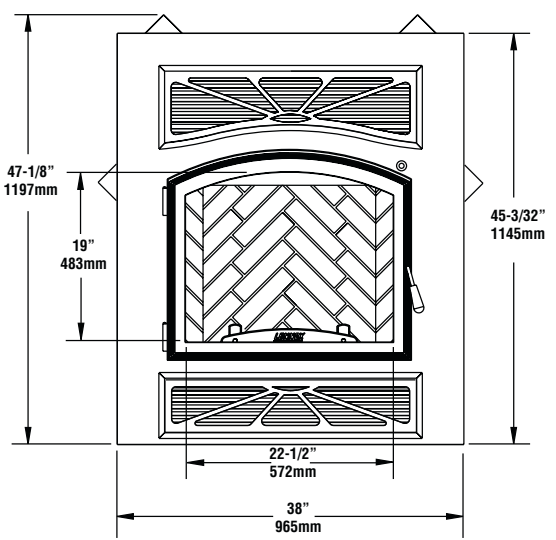
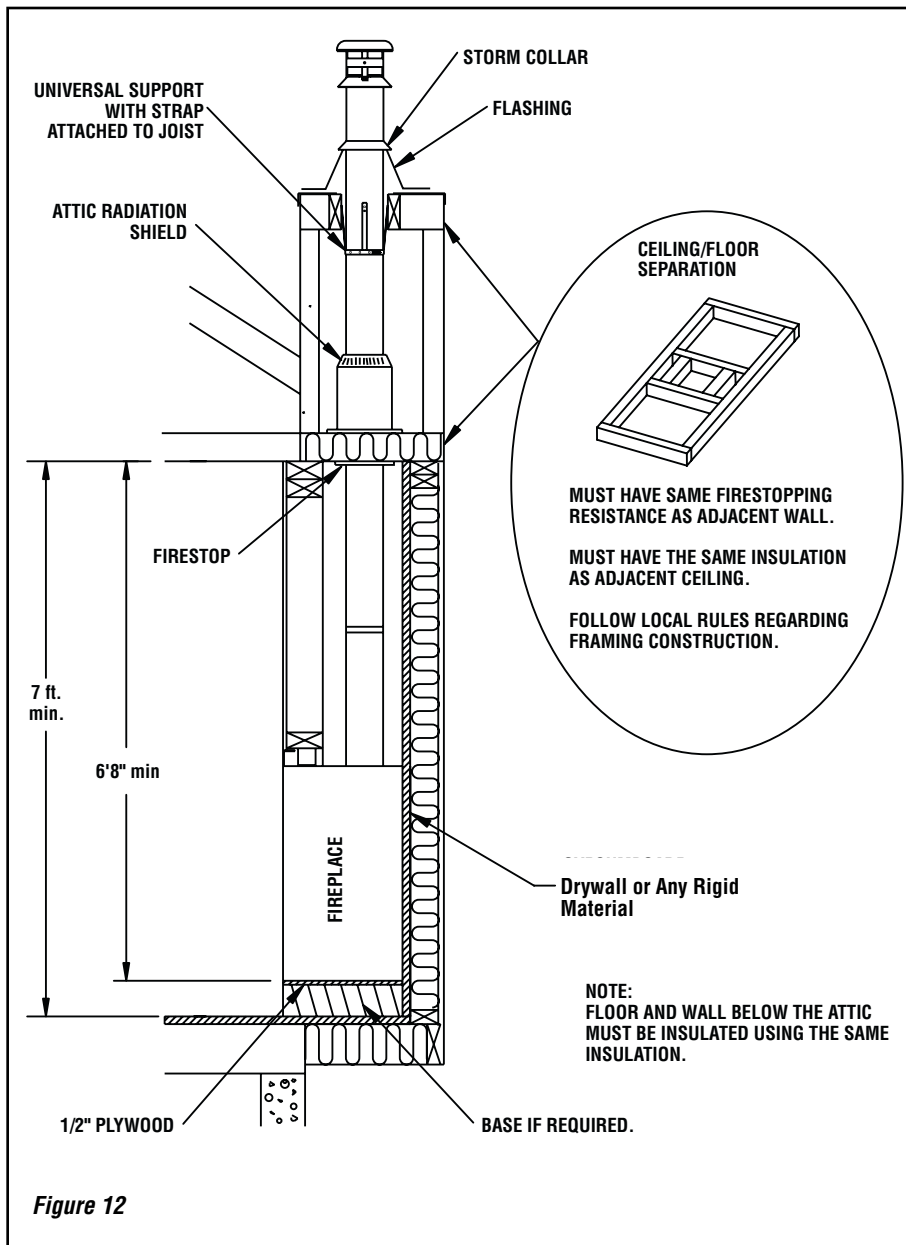

Figure 11 - Framing Dimensions

INSULATED CHASE CONSTRUCTION



Chase Enclosure

A chase is a vertical box-like structure constructed to surround the fireplace and chimney. Refer to **Figure 12** for a typical chase configuration. As with all chimney installations, avoid overhead obstructions such as trees, power lines, etc. A chase should be constructed and insulated just like any outside wall. In a cold climate, we recommend the base of the chase should also be insulated between the solid continuous floor beneath the fireplace and the chase bottom. Chase insulation in a cold climate installation is not required for safety.

WARNING

If insulation is used, the fireplace must not be placed directly against it. Insulation or vapor barriers, if used, must first be covered with drywall panels, plywood, particle board or other material to assure insulation and vapor barriers remain in place.

WARNING

Do not pack or fill required air spaces with insulation or other material. No material is allowed in these areas.

Note: Do not insulate the chase cavity with blown or fill type insulation materials.

Note: Local codes may not require firestopping at the ceiling levels for outside chase installations. However, it is recommended for safety and the reduction of heat loss.

Facing

1. Combustible wall (such as drywall panels) must be installed flush with the fireplace. It may not project in front of and on the fireplace (i.e. the steel facade of the fireplace) (see **Figure 13**).
2. Decorative frame made of combustible material cannot project in front of and on the fireplace steel front, in the space delimited by the width of the unit (38") and a height of 54" from the base of the appliance (see **Figure 15**).
3. Non-combustible materials such as brick, stone or ceramic tile may project in front of and onto the fireplace facing (see **Figure 14**).

Mantel

The mantel must be installed at least 54" (1372 mm) above the base of the fireplace (see **Figure 13**).

***NOTE:** Mantel can be reduced to 48" (1219 mm) if the Clean Face Panel option is installed with the gravity kit.

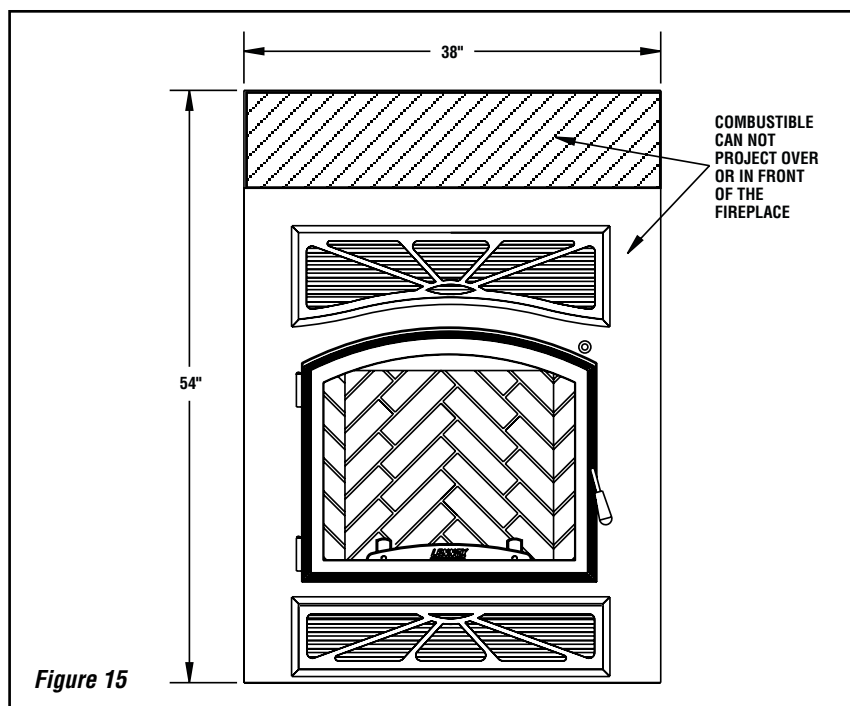
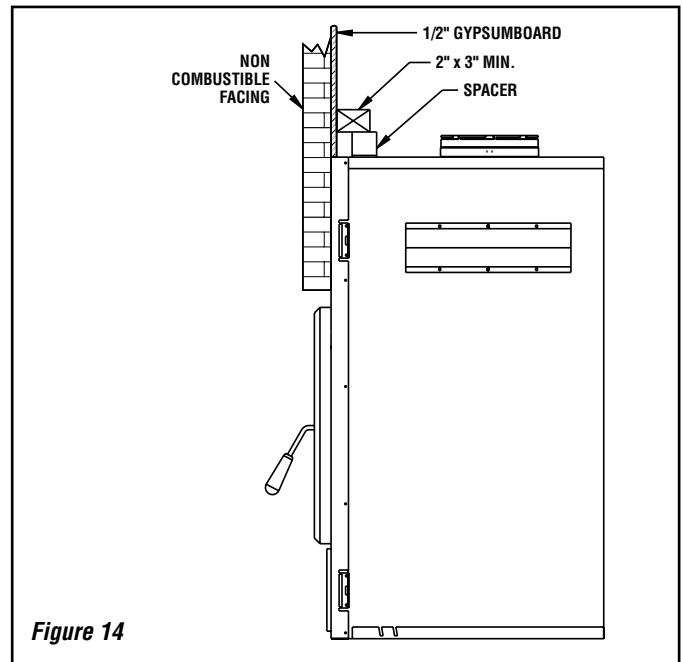
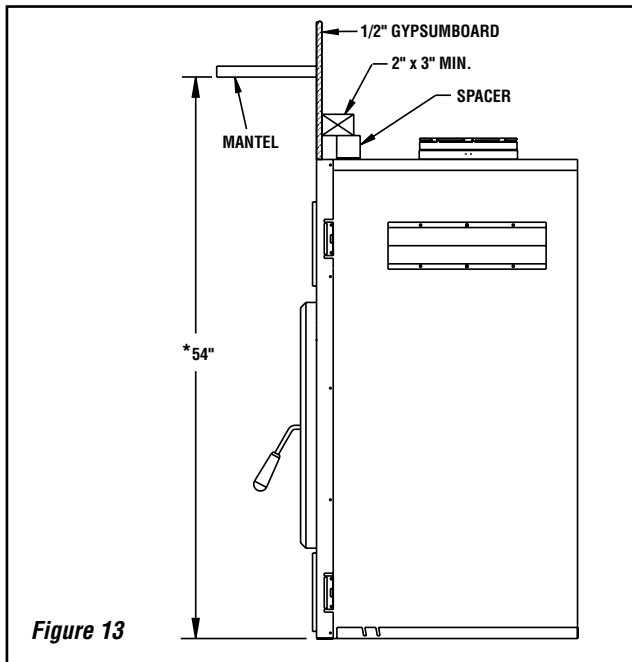

HOT AIR DUCTING INSTALLATION

Gravity Kit

Double hot air outlet includes:

(see **Figure 16**)

- 2 telescopic lengths 8" I.D.
- 2 90° elbows 8" I.D.
- 2 hot air outlet kits (louvers and frames)
- 2 adaptors

See components list **Page 22**.

The gravity kit allows you to block the upper grill of the fireplace with a clean face panel. To do so, follow the steps below:

- a) Remove the upper grill and its frame from the fireplace.
- b) Install the panel for clean face (H3290) making sure that the insulation strip is installed inside.

The fireplace facade can be covered with non-combustible material (as shown in **Figure 14** on **Page 12**).

The safety rules for hot air ducting gravity kit installations are the following:

Minimum height* 68" (1727 mm)

Maximum length - See **Figure 17**

- * The height of the louver must be measured from the base of the Villa Vista™ fireplace to the middle point of the louver.

When installing the double outlet system, the hot air outlets can be installed in the same room as the fireplace, or one or both of the outlets can be installed in adjacent or upper rooms. Installing the ducts at different elevations will tend to exhaust more heat out of the higher outlet (see **Figure 17**).

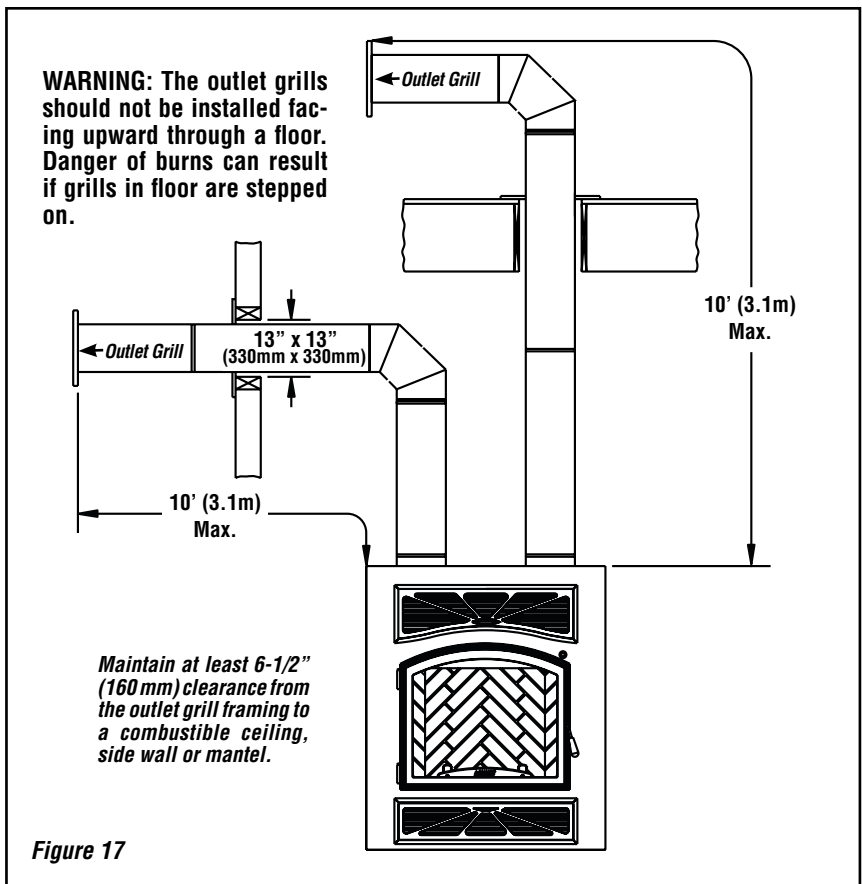
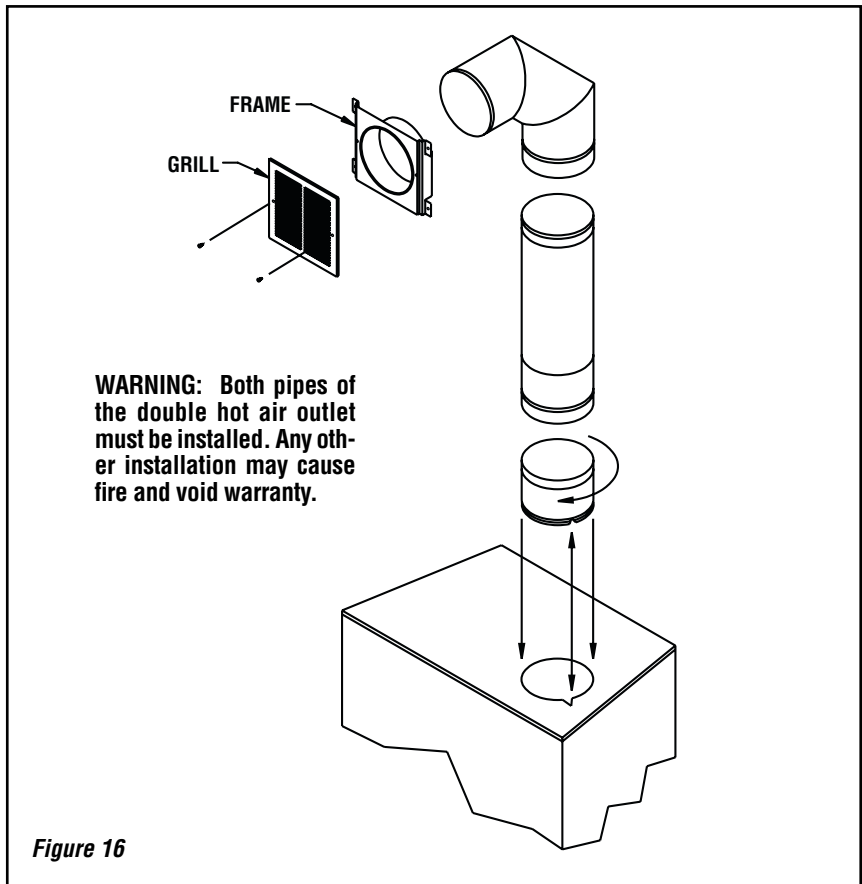

The duct system must be installed respecting the following:

1. Remove the top and bottom plates closing up the 8" diameter holes on top of the fireplace. Then, cut the insulation in order to obtain two 8" diameter openings. Fix the adaptors on the fireplace openings by turning clockwise (refer to **Figures 16 and 17**).

2. Maintain at least a 2" (50mm) clearance between the ducts and any combustible material; the required hole size is 13" x 13" (330 mm x 330 mm).

Exception: For the grills, the framing can be 10-3/4" x 10-3/4" (275 mm x 275 mm) to provide the clearance as required by the integral spacers on the double outlet duct system.

3. The maximum number of elbows in a run of duct is two.

4. Maintain at least 6-1/2" (160 mm) clearance from the outlet grill framing to a combustible ceiling, side wall or mantel.

5. When traversing a combustible wall or floor, a firestop must be installed at the wall or floor penetration. The hole size must be 13" X 13". (330 mm x 330 mm).

6. Do not connect the hot air ducts to a central heating system. Malfunction of the heating system's fan will cause the furnace duct to overheat. A furnace duct is only single wall and not double wall as is required for the Villa Vista™ fireplace hot air exhaust.

7. Use only Lennox Hearth Products grills and components as described in this manual. Other grills or registers, for example, may be too restrictive and may overheat the fireplace or ceiling.

8. Do not use insulated flexible ducts as they will overheat.

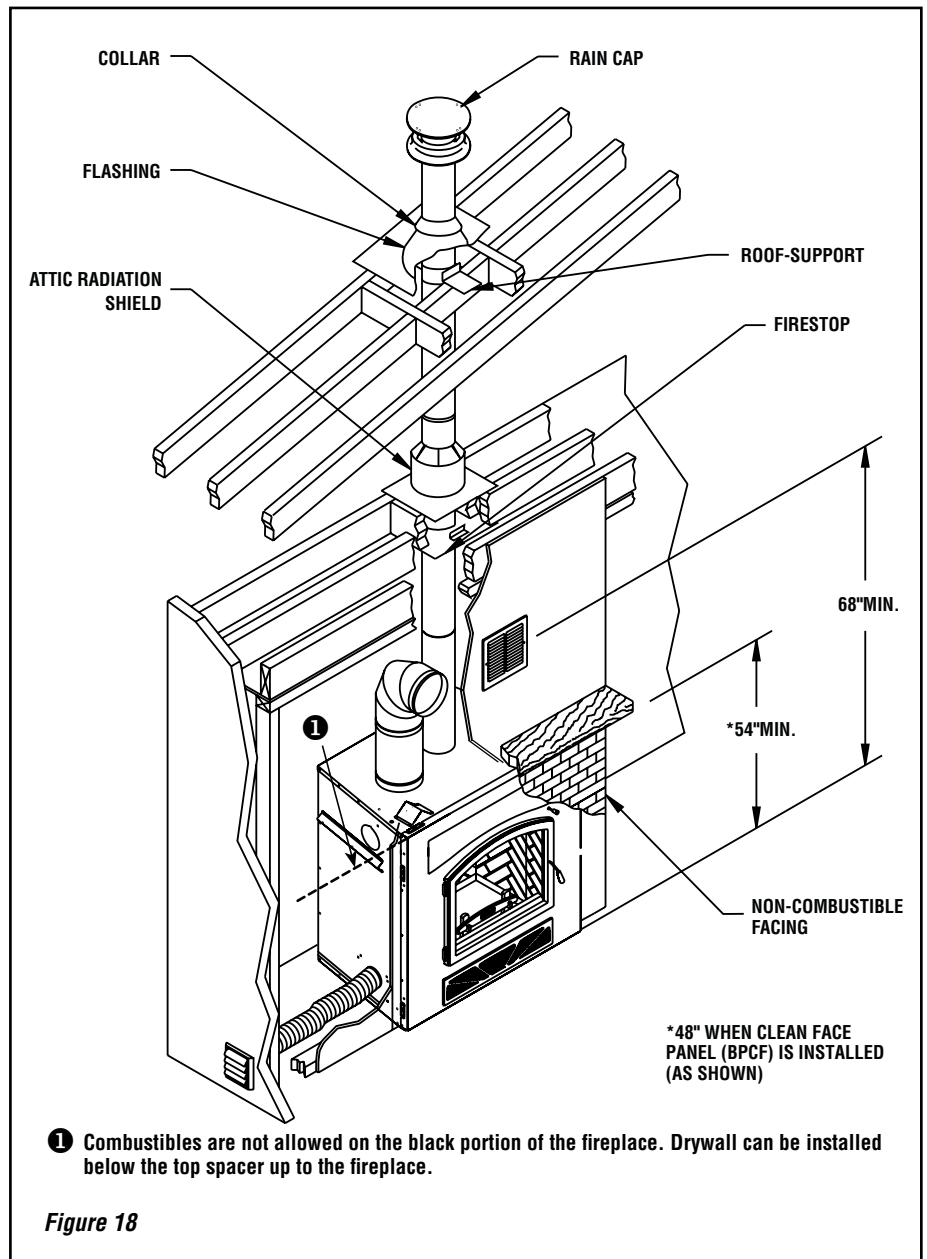

9. Do not use tees or any other components than the ones specifically listed here.

10. All ducts must extend upwards or horizontally. Never try to route the ducting downwards.

11. The hot air outlet grills must be installed with the louvers pointing downwards in order to prevent overheating adjacent ceilings.

12. Do not install outlet grills facing upward in a floor. They will get hot and create a risk of burns if stepped on.

OUTSIDE AIR KIT

During operation, the fireplace requires fresh air for combustion and draws air from outside the house. It may starve other fuel burning appliances such as gas or oil furnaces. As well, exhaust fans may compete for air, causing negative pressure in the house, resulting in smoke entering the house from the fireplace. This situation is aggravated in modern airtight houses. To overcome this potential problem, we **require the installation of an outside air assembly**.

The outside air assembly must be installed according to the following requirements :

1. Duct length should be kept to a minimum. The maximum length of a 4" I.D. (100mm) insulated flexible duct is 20 feet (6.1 m). The duct can be extended to a maximum of 40 feet (12 m) using a 6" I.D. (150mm) insulated flexible duct.
2. The air intake register must not be installed more than 7 feet (2135 mm) above the base of the fireplace.
3. The fresh air must come from outside the house. The air intake must not draw air from the attic, from the basement or garage.
4. The air intake register should be installed where it is not likely to be blocked by snow or exposed to extreme wind and well away from automobile exhaust fumes, gas meters and other vents.
5. The duct and register may be installed above or below floor level.

Outside Air Installation

Make a 4-1/4" (110 mm) hole in the outside wall of the house at the chosen location. From outside, place the outside air register in the hole (open side down) and fasten the register to the wall, with screws as shown (see **Figure 19**). Slip the pipe into the insulated sleeve. Place the insulated pipe over the register tube and over the fireplace's outside air connector (see **Figure 20**). At each end, carefully pull back the insulation and plastic cover exposing the flexible pipe.

Using the aluminium tape provided, wrap the tape around the joint between the flexible pipe and the air inlets. Carefully push the insulation and plastic cover back over the pipe. Using aluminium tape, fasten the plastic cover in place.

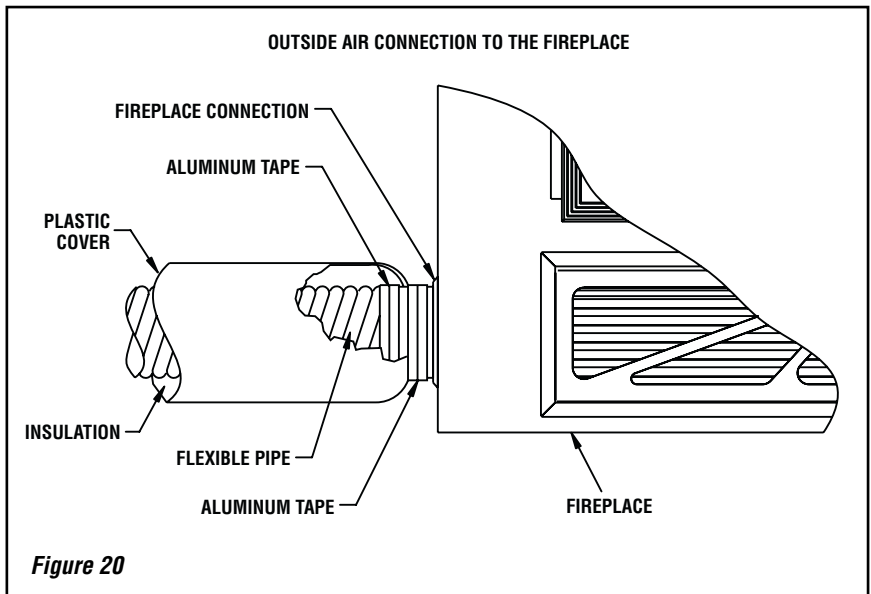
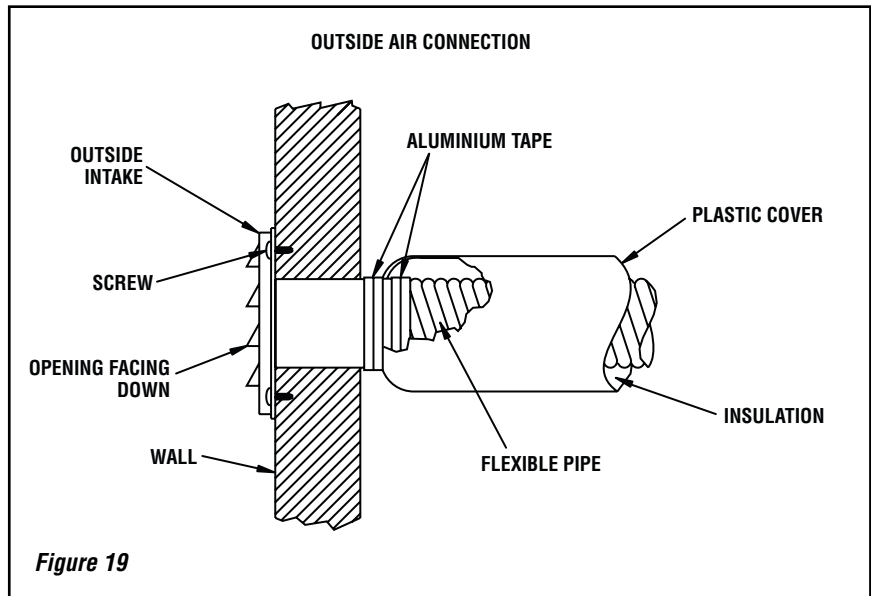

CHIMNEY SYSTEM

CHIMNEY INSTALLATION NOTES

1. If possible, install an interior chimney as it will provide better performance. In areas with continuous temperatures below 0° F (18° C), the use of an exterior chimney increases the likelihood of operating problems such as low draft, high rate of creosoting, and poor start-up characteristics. Exterior chimneys are also prone to down-drafting and flow reversal. Installations, which are located on lower floors in the house, such as in a basement, in combination with outside chimney, are especially prone to flow reversal.
2. The Lennox fireplace model VILLA VISTA™ fireplace is listed only with Security Chimneys International Ltd. 7" diameter chimney systems models ACBI or ASHT+ or S2100+.

Note: Use of ACBI chimney with these fireplaces require the use of a starter section used at the fireplace top collar. Use H3805 (ACBI7SBA) or H3806 (ACBI7SB30).
3. A chimney venting a fireplace shall not vent any other appliance.
4. The minimum chimney height is 12 feet (3.7 m). In altitude, add 18" (450 mm) to the chimney for every 2000 feet (600 m) above sea level.
5. All chimney installations must include at least one support. The maximum chimney length that can be supported by the fireplace is 20 feet (8m) for ACBI chimney and 12 feet (3.7 m) for ASHT+ chimney.
6. The chimney must extend at least 3 feet (915 mm) above its point of contact with the roof and at least 2 feet (610 mm) higher than any wall, roof or building within 10 feet (3m) of it (see **Figure 21**).
7. If the chimney extends higher than 5 feet (1500 mm) above its point of contact with the roof, it must be secured using a brace and guy wires.
8. A rain cap must be installed on top of the chimney. Failure to install a rain cap may cause corrosion problems.
9. Portions of the chimney which may extend through accessible spaces must be enclosed to avoid contact with combustible materials or damage to the chimney.

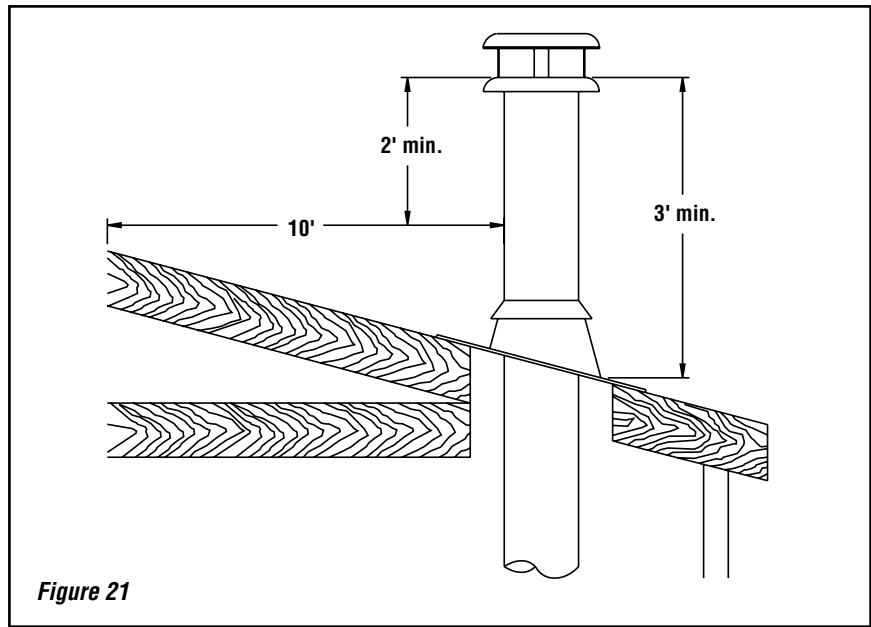

NOTE: DIAGRAMS & ILLUSTRATIONS ARE NOT TO SCALE.

ACBI CHIMNEY INSTALLATION

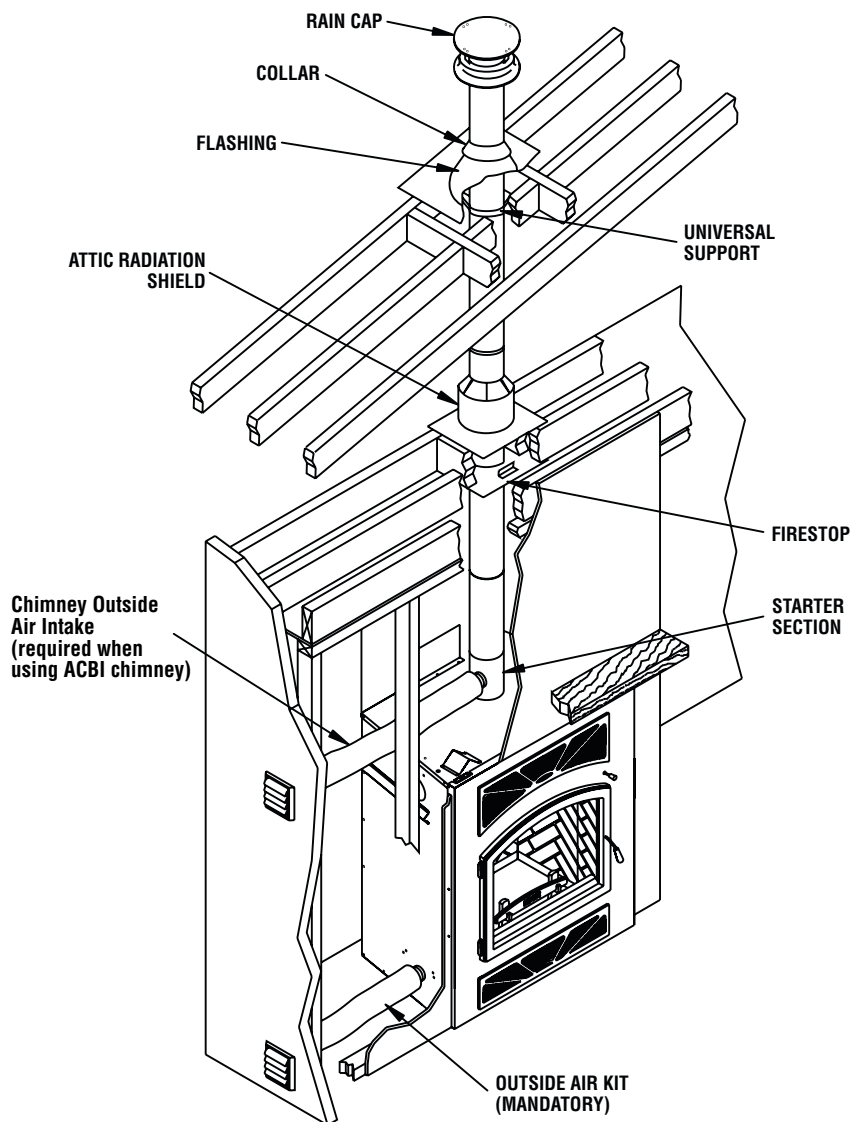

Figure 22

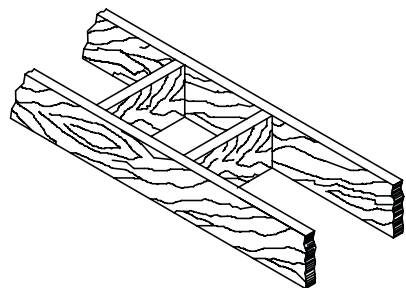

Figure 23

2. From below, install a firestop in each ceiling/floor separation through which the chimney will pass. At the attic level, install an attic radiation shield from above, (see **Figure 24**). S2100+ and ASHT+: Place the first chimney length on the fireplace, to lock turn 1/4 of a turn clockwise. ACBI: A starter section must be installed before installing the first chimney length (see **Figure 22**).

3. ACBI: Every 20 feet and at the roof level, install a universal support fastening the straps to the surrounding joists. ASHT+: Install support as required (see Chimney Support Installation Section on **Page 20**).

4. Put the roof flashing in place and seal the joint between the roof and the flashing with roofing pitch (see **Figures 25 and 26**). For sloping roofs, place the flashing under the upper shingles and on top of the lower shingles. Nail the flashing to the roof, using roofing nails.

5. Place the storm collar over the flashing and tighten it with the bolt supplied. Finally, seal the joint between the storm collar and the chimney, using silicone caulking.

6. Install the chimney cap.

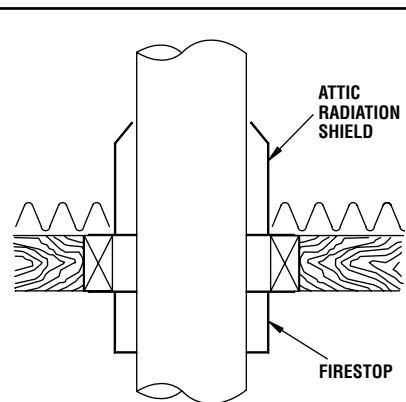

Figure 24

CHIMNEY INSTALLATION INSTRUCTIONS

1. Cut and frame the holes in the ceiling, floor and roof where the chimney will pass (see **Figure 23**). Use a plumb-bob to line up the center of the holes. The sizes are indicated in **Table 1** for the wall and ceiling holes and **Table 2** (**Page 18**) for the roof holes.

NOTE: ACBI chimney require 1" clearance going through ceiling and roof and 2" clearance through a wall. ASHT+ chimney require 2" clearance. **Do Not fill this air space with insulation or any combustible material.**

CHIMNEY MODEL	SQUARE HOLE SIZE OPENING
ASHT+	13-3/8" (314 mm)
S2100+	15-1/8" (359 mm)
ACBI: Ceiling (1" clearance)	15 in (380 mm)
ACBI: Wall	17 in (432 mm)

*Note: See Table 2 for Sloped Roof Framing
Table 1 - Flat Roof Framing*

NOTE: DIAGRAMS & ILLUSTRATIONS ARE NOT TO SCALE.

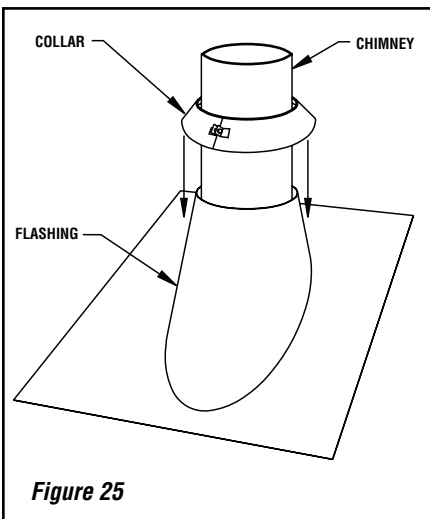

Figure 25

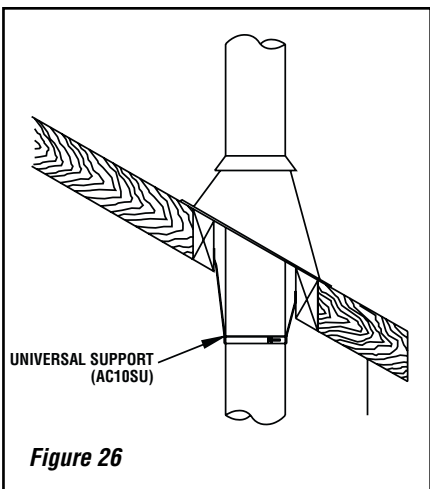

Figure 26

OFFSET CHIMNEY INSTALLATION

For the minimum chimney height when using elbows, see **Table 3** and refer to **Figure 27**.

Note: Use of ACBI chimney with these fireplaces require the use of a starter section used at the fireplace top collar. Use H3806 (ACBI7SB30) offset starter for offset installations.

Minimum Chimney Height When Using Elbows	
Vertical installation	12 feet (3.66 m)
Two (2) elbows	15 feet (4.57 m)
Four (4) elbows	17 feet (5.18 m)

Table 3

After reaching the location requiring the elbow, proceed as follows:

1. Install the first elbow. Turn it in the required direction. ACBI: To lock it in place, turn 1/8 of a turn. Fasten the straps attached to the elbow to the surrounding frame, using nails or drywall screws. ASHT+ and S2100+: Fasten it to the chimney with three (3) 1/2" metal screws, provided with the elbow.

2. Install the necessary chimney lengths to achieve the required offset. Lock the chimney length together. It is recommended to use three (3) metal screws. If penetrating a wall, use a wall radiation shield.

3. Use another elbow to turn the chimney vertically. ACBI: Lock it to the chimney. Fasten the straps attached to the elbow to the surrounding framing using nails or drywall screws. ASHT+ and S2100+: Fasten it to the chimney with three (3) 1/2" metal screws, provided with the elbows.

4. Use a plumb-bob to line up the center of the hole. Cut a hole for the chimney in the ceiling. Frame this hole as described previously.

5. From below, install a firestop (refer to **Figure 27**). ASHT+ and S2100+: A support must be used after the offset.

6. Continue with the regular installation.

Roof Down Slope Hole Size			
Degree Of Slope	ACBI 7"	ASHT+ 7"	S2100+ 7"
0 *	15" (380mm)	13-3/8" (340mm)	15-1/8" (384mm)
2/12	15-5/8" (390mm)	13-5/8" (345mm)	15-3/8" (390mm)
4/12	16-1/8" (410mm)	14-1/8" (359mm)	16" (406mm)
6/12	15" (380mm)	15" (380mm)	17" (432mm)
8/12	18-1/4" (465mm)	16-1/8" (410mm)	18-1/4" (465mm)
10/12	19-5/8" (499mm)	17-1/2" (445mm)	19-3/4" (502mm)
12/12	21-3/8" (545mm)	19" (483mm)	21-3/8" (545mm)

Table 2 *CROSS SLOPE HOLE SIZE

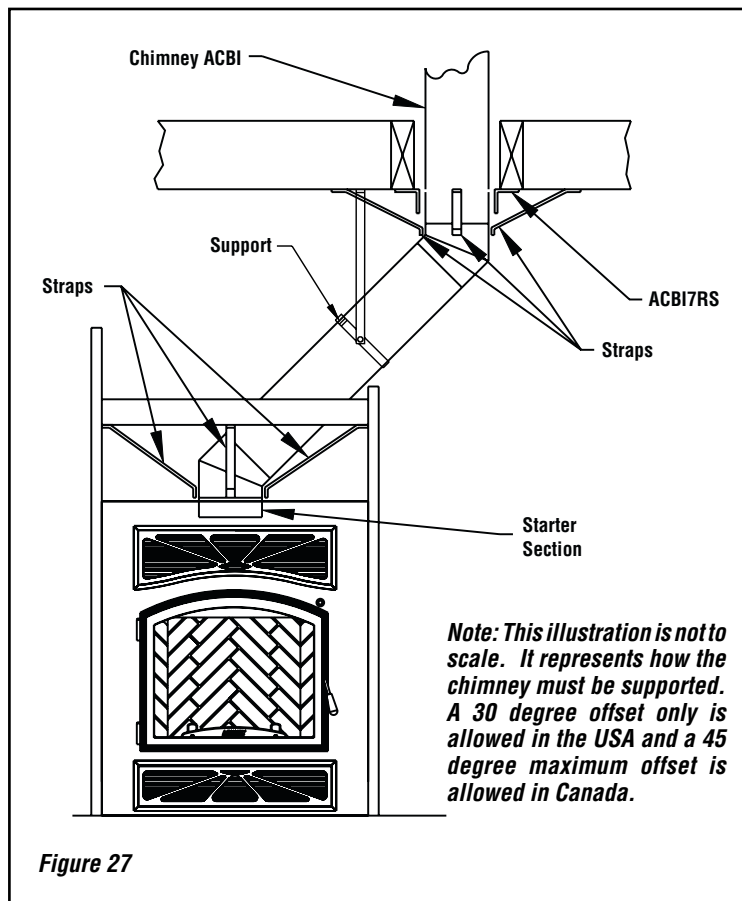
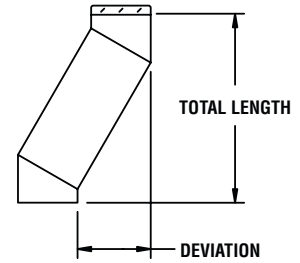

Figure 27

CHIMNEY 7"	ELBOW	DEVIATION & LENGHT	ONE LENGTH BETWEEN ELBOWS				TWO LENGTHS BETWEEN ELBOWS			
			12"	18"	36"	48"	12" & 48"	18" & 48"	36" & 48"	48" & 48"
ACBI	15	DEVIATION	5 1/2" (140 mm)	7" (178 mm)	11 1/2" (292 mm)	14 3/4" (375 mm)	17 1/2" (445 mm)	19" (483 mm)	23 5/8" (600 mm)	26 3/4" (679 mm)
		LENGTH	32 1/4" (819 mm)	38" (965 mm)	55 1/2" (1410 mm)	67" (1702 mm)	77 1/8" (1959 mm)	82 7/8" (2105 mm)	100 1/4" (2218 mm)	111 1/8" (2823 mm)
	30	DEVIATION	10 1/2" (267 mm)	13 1/2" (343 mm)	22 1/2" (543 mm)	28 1/2" (724 mm)	33 3/4" (857 mm)	36 3/4" (933 mm)	45 3/4" (1162 mm)	51 3/4" (1314 mm)
		LENGTH	30 1/8" (765 mm)	35 3/8" (899 mm)	51" (1295 mm)	61 3/8" (1559 mm)	70 1/2" (1791 mm)	75 5/8" (1921 mm)	91 1/4" (2318 mm)	101 5/8" (2581 mm)



CHIMNEY 7"	ELBOW	DEVIATION & LENGHT	ONE LENGTH BETWEEN ELBOWS					TWO LENGTHS BETWEEN ELBOWS				
			8"	12"	18"	24"	36"	8" & 36"	12" & 36"	18" & 36"	24" & 36"	36" & 36"
S2100+	15	DEVIATION	3" (76 mm)	4 1/4" (108 mm)	5 3/4" (146 mm)	7 1/4" (184 mm)	10 1/4" (260 mm)	12 1/4" (311 mm)	13 1/4" (337 mm)	14 3/4" (375 mm)	18 1/4" (413 mm)	19 1/2" (495 mm)
		LENGTH	16 1/2" (419 mm)	20 1/4" (514 mm)	26 1/4" (667 mm)	33" (813 mm)	43 1/2" (1105 mm)	50 1/2" (1383 mm)	54 1/4" (1378 mm)	80" (1524 mm)	85 3/4" (1670 mm)	77 1/2" (1969 mm)
	30	DEVIATION	7 1/2" (191 mm)	9 1/2" (241 mm)	12 1/2" (318 mm)	15 1/2" (394 mm)	21 1/2" (546 mm)	25" (635 mm)	27" (686 mm)	30" (762 mm)	33" (838 mm)	39" (991 mm)
		LENGTH	20 3/4" (527 mm)	24 1/4" (618 mm)	29 1/2" (749 mm)	34 3/4" (883 mm)	45" (1143 mm)	51 1/4" (1338 mm)	54 3/4" (1391 mm)	80" (1524 mm)	85 1/4" (1657 mm)	75 1/2" (1918 mm)

CHIMNEY 7"	ELBOW	DEVIATION & LENGHT	ONE LENGTH BETWEEN ELBOWS					TWO LENGTHS BETWEEN ELBOWS					
			8"	12"	18"	24"	36"	48"	8" & 36"	12" & 48"	18" & 48"	24" & 48"	36" & 48"
SECURE TEMP ASHT+	15	DEVIATION	3 5/16" (84 mm)	4 5/16" (110 mm)	5 7/8" (149 mm)	7 7/16" (189 mm)	10 1/2" (268 mm)	13 5/8" (346 mm)	15 3/8" (391 mm)	16 7/16" (418 mm)	18" (457 mm)	19 1/2" (495 mm)	22 5/8" (575 mm)
		LENGTH	15 11/16" (398 mm)	19 9/16" (497 mm)	25 3/8" (645 mm)	31 3/16" (792 mm)	42 3/4" (1086 mm)	54 3/8" (1381 mm)	60 15/16" (1548 mm)	64 13/16" (1646 mm)	70 9/16" (1792 mm)	76 3/8" (1940 mm)	87" (2210 mm)
	30	DEVIATION	7 7/16" (189 mm)	9 7/16" (240 mm)	12 7/16" (316 mm)	15 7/16" (392 mm)	21 7/16" (545 mm)	27 7/16" (697 mm)	30 13/16" (783 mm)	32 13/16" (833 mm)	35 13/16" (907 mm)	38 13/16" (986 mm)	44 13/16" (1138 mm)
		LENGTH	20" (508 mm)	23 1/2" (597 mm)	28 11/16" (729 mm)	33 7/8" (860 mm)	44 1/4" (1124 mm)	54 11/16" (1389 mm)	60 9/16" (1538 mm)	64" (1626 mm)	69 1/4" (1759 mm)	74 7/16" (1891 mm)	84 13/16" (2154 mm)

Note: With the ACBI chimney, a starting length of 6" high must be used on top of the fireplace before installing elbow.

Table 4

ANGLED WALL RADIATION SHIELD

When traversing a combustible wall with the chimney at a 30° angle, an angled insulated wall radiation shield must be installed. Only one is required.

AC10RSMI30 & 7RSMI30		
CHIMNEY MODEL	ANGLE	HOLE SIZE
ACBI	30°	17" x 42-1/2" (432 x 1080 mm)
ASHT	30°	13-3/8" x 33-1/4" (340 mm x 845 mm)
S2100+	30°	15" x 38-1/4" (380 mm x 972 mm)

Table 5

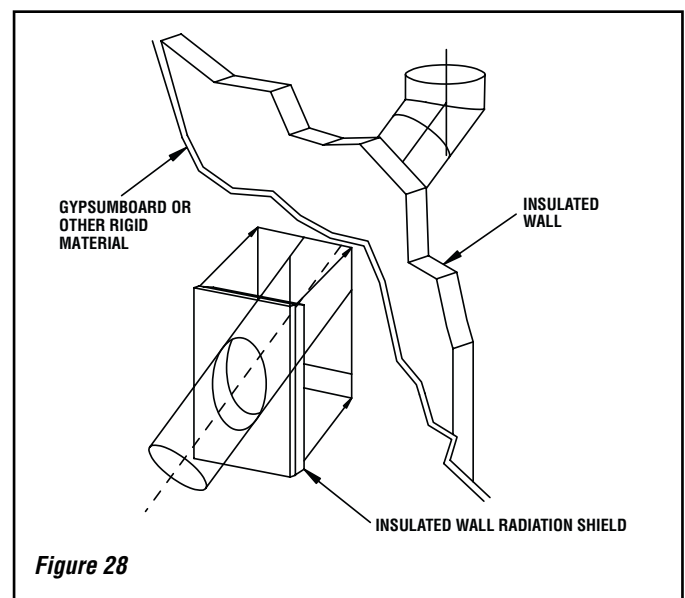

Figure 28

CHIMNEY SUPPORT INSTALLATION

Universal Roof Support

This support has two possible uses:

1. For ASHT+ it must be used on a roof to support the chimney.
2. It may be used on a floor, ceiling or roof above an offset to support the chimney above the offset.
3. It may be used on a floor, ceiling or roof above as a supplementary support when the chimney height exceeds 15 feet (4.6 m).

Table 6 gives maximum height of supported chimney.

NOTE: For the ACBI chimney, a universal section must be used every 20 feet (6 m) instead of the universal roof support (ST).

For roof support installation, refer to the instructions provided with the support.

Universal Offset Support

This support is used to support the chimney above an offset. Or it may be used on the wall to support the chimney. The maximum heights are given in **Table 6**. For offset support installation, refer to the instructions provided with the support.

CHIMNEY MODEL	MAXIMUM HEIGHT OF SUPPORTED CHIMNEY	
	Offset Support	Roof Support
ACBI	40 feet (12.91m)	50 feet (15.02m)
ASHT+	24 feet (8.54m)	27 feet (8.84m)
S2100+	16 feet (5.42m)	18 feet (6.10m)

Table 6

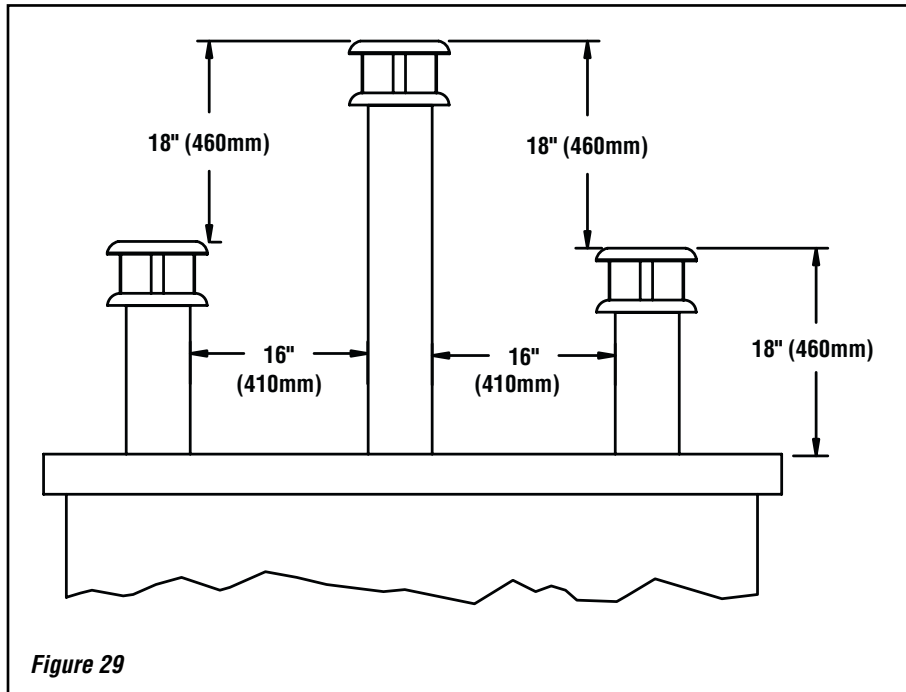

Figure 29

CHIMNEY CHASE AND MULTIPLE TERMINATIONS

For the purpose of this manual, a chimney chase is considered a part of the chimney system rather than part of a building. The termination must be placed a minimum of 18" (460 mm) above the chase.

For installations where more than one chimney is located in the same chase or within the same area, we suggest that their terminations be separated by at least 16" (410 mm) horizontally, and 18" (460 mm) vertically. This separation is to prevent smoke migration from one chimney to another (see **Figure 29**).

CHIMNEY ADAPTOR (S2100+)

The fireplace is normally supplied with a chimney adaptor suitable for the ASHT+ chimney. If you want to install a S2100+ chimney, an adaptor is available (7UCA) (see **Figure 30**). If installing ACBI, adaptor H3805 (ACBISB) or offset adaptor H3806 (ACBISB30) is required.

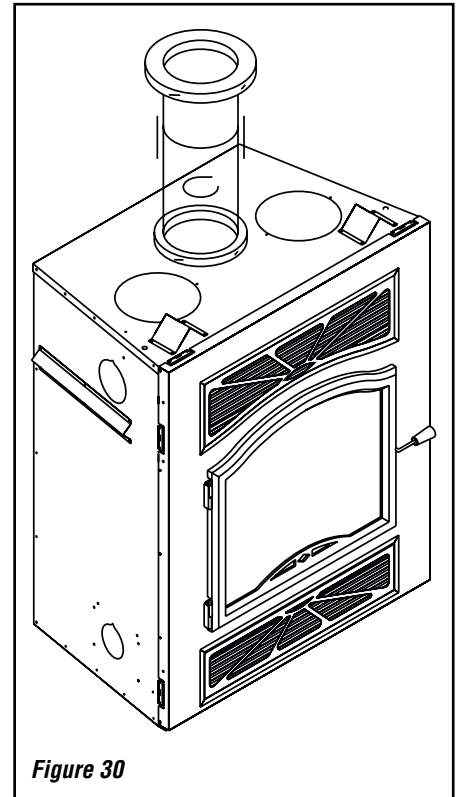

Figure 30

INSTALLATION INSTRUCTIONS FOR MASONRY APPLICATIONS

! WARNING

Before starting the installation, the masonry chimney must be inspected by a qualified chimney sweep.

The following requirements must be met:

1. The chimney must be absolutely clear of any soot residue or creosote. Check for cracks, loose or missing bricks that could inhibit correct installation of the liner.
2. The clearance to combustible must be a minimum of 1" between the outside of the masonry and any wood framing or loose insulation.
3. The chimney must be built in accordance with the current building code.
4. No other appliance can be connected to the same chimney.
5. The clearances to combustible for the BISPMA30 connectors are 2" on the side and bottom and 16" at the top.
6. The connector parts are not necessary if the connection between the insulated length and the stainless steel liner is done within the masonry chimney.

Installation:

The chimney must be relined with a stainless steel liner model TUBINOX or PROJET SS of the same diameter as the outlet of the fireplace.

For connection at a 30° angle, a special connector (BISPMA30) must be used to connect the liner to the insulated chimney.

*** IMPORTANT NOTE - The use of a 45° connector (BISPMA) is approved for use in Canada ONLY. Installations in the USA must use the 30° connector (BISPMA30).**

See **Figure 31** for typical installation.

Follow these steps:

- 1- Position the fireplace in its location. Temporarily install the ASHT+ elbow on the top of the fireplace and, using a level, mark with an oval the location where the flue liner will enter the masonry chimney.
- 2- In the middle of the oval, drill a hole in the masonry chimney at 45° or 30°.

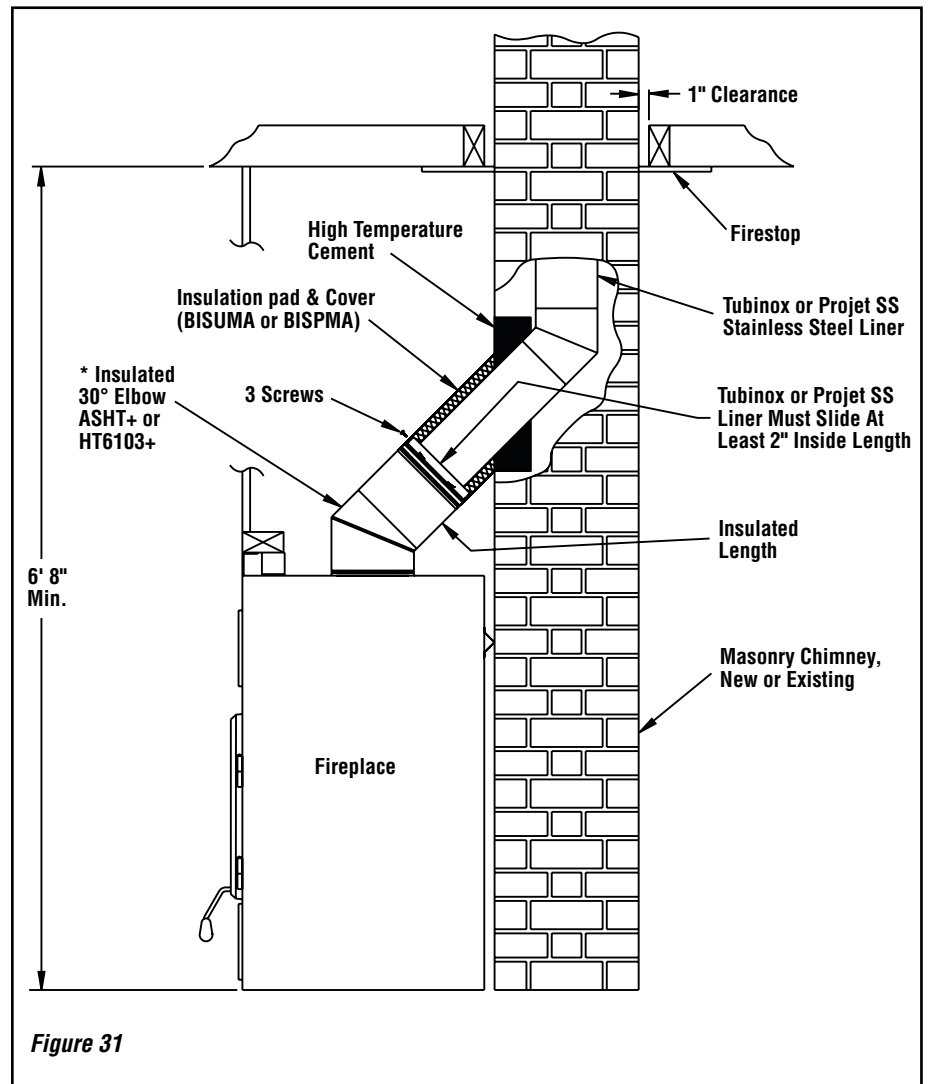

Figure 31

Note: 45° offsets allowed in Canada only.

- 3- Increase the size of the hole until a 45° or 30° TUBINOX liner elbow can be easily slipped through.
- 4- Slide the liner down from the top of the masonry chimney until you reach the hole level.
- 5- Slip through the hole a 45° or 30° liner elbow and connect it to the liner.
- 6- Add a small liner section to the liner elbow which will allow the liner to extend at least 12" (measured at the top of the liner) from the masonry chimney.
- 7- Seal the opening around the liner with high temperature refractory cement.
- 8- The next steps must be done in the following order :

- A. Select the ASHT+ length that will fit between the elbow and the liner so that it will slide at least 2" over the liner section. (You may need to cut the liner for a better fit).
- B. Take that section and the BISUMA30 cover and slide it over the liner. Make sure you have enough opening to be able to install the ASHT+ elbow without difficulty.
- C. Install the 45° or 30° elbow on the fireplace.
- D. Slide the length section back down on the elbow and twist lock the two together.
- E. Pull the cover down over the length and install the insulation pad over the liner; be careful to cover the liner completely.
- F. Slide back the cover over the insulation and fix it in place using the 3 metal screws supplied.

VILLA VISTA™ COMPONENTS LISTS

Installation Accessories	
Description	Cat./ Part No.
Decorative Cast Iron Door (Required - Order Separately)	
Arch Shape Door, Gold Plated	H3279
Arch Shape Door, Black	H3280
Arch Shape Door, Brushed Nickel	H3281
Gravity Kit	
Gravity Kit: Complete double duct system includes: 2 90° elbows, 2 telescopic lengths, 2 grill supports & 2 black grills, 2 fireplace adaptors	7B30ZK-1
Gravity Kit Accessories	
Black grill with support (set of 2)	7B30Z0
Brass grill (for 7B30ZK-1)	7B30ZGB
Elbow 90°, 8" dia. I.D.	7B26ZE90
Elbow 45°, 8" dia. I.D.	7B26ZE45
Telescopic Length, 8" dia. I.D. (15" - 26")	7B26ZLA
Adjustable Length, 8" dia. I.D. (2" - 5")	7B26ZL2A
Radiation Shield, 8" I.D.	7B26ZR
Length 5 ft., 8KL5	8KL5
Length 4 ft., 8KL4	8KL4
Length 3 ft., 8KL3	8KL3
Length 2 ft., 8KL2	8KL2
Length 1 ft., 8KL1	8KL1
Outside Air Kit (Required - Included with Fireplace)	
outside Air Coupler to Connect Outside Air UZI to Fireplace, UZIAD	UZIAD
Outside Air Ducting - Includes 4 ft. Insulated Flex x 10 ft. long, UZI	UZI

Fireplace Options	
Description	Cat./ Part No.
Del Sol Louver Kit	DEL SOL
Diamante Louver Kit	DIAMANTE
Fiori Louver Kit	FIORI
Luna Louver Kit	LUNA
Strada Louver Kit	STRADA
Panel for Clean Face Option	BPCF
Blower	UZY5
Blower Motor Speed Control	VRUW
Rigid Firescreen	BPZN

Fireplace Model VILLA VISTA - Approved Venting Components

7" Diameter Chimney - Model ASHT+, S2100+, HT6000+, HT6103+ or ACBI manufactured by Security Chimneys International only.

7" Diameter Chimney for Relining Masonry Chimneys - TUBINOX chimney (or PROJET SS), 7" diameter with adaptor for installation in a masonry chimney.

Notes:

- ① (Projet NovaTemp™) HT6000+ equivalent to S2100+
- ② (Projet NovaTemp™) HT6103+ equivalent to ASHT+
- ③ This appliance is equipped with the ASHT Chimney Adaptor. When other chimney is used, a chimney adaptor for the chimney will be required.
- ④ Chimney Adaptor (S2100+ / HT6000+) for CANADA ONLY - If you want to install a S2100+ / HT6000+ chimney, an adaptor is available (6UCA).
- ⑤ AC Chimney is Not recommended at elevations above 4000 feet or in cold climates, where temperatures fall below 32° F (0 °C). When using AC chimney, an ACBI7SBA starter section must be used before installing an elbow. When an offset is needed immediately off the top of the fireplace, an elbow starter section is available (ACBI7SBA30) is available.

VILLA VISTA™ COMPONENTS LISTS

ACBI Chimney <i>(AC - Air Cooled - 7" I.D., 13" O.D.)</i>	
Description	Cat./ Part No.
Lengths and Misc. Chimney Components	
12" Length, 7" Dia., ACBI7L12	H3252
18" Length, 7" Dia., ACBI7L18	H3253
36" Length, 7" Dia., ACBI7L36	H3254
48" Length, 7" Dia., ACBI7L48	H3255
15° Elbow, 7" Dia., ACBI7E15	H3256
30° Elbow, 7" Dia., ACBI7E30	H3257
Rain Termination Cap (regular), 7" Dia., ACBI7CPR	H3260
Spark Arrester Screen (band), PE+	PE
Starter Adaptors <i>One of the following is required if installing ACBI Chimney</i>	
Starter Section w/ Air Intake, 7" Dia., ACBI7SBA	H3805
Offset Starter Section 30°, 7" Dia., ACBI7SBA30	H3806
Outside Air Kit <i>The following components are required if installing ACBI Chimney</i>	
Outside Air Kit (chimney) (4" I.D. flex x 10" long, insulation, outside register and coupling), ACZI	H1967
Outside Air Coupler for AC Chimney 4" I.D., UACZI	H3274
Supports	
Support Section (10" long), ACBI7SL	H3263
Universal Support, AC10SU	H3265
Roof Flashings	
1/12 - 7/12 (5° - 30°), Adjustable, ACBI7FAR	H3276
8/12 - 12/12 (30° - 45°), Adjustable, ACBI7FBR	H3277
Flat Roof Flashing (includes spacer and collar), ACBI7FR	H3275

Misc.	
Description	Cat./ Part No.
Firestop, ACBI7BF	H3268
Radiation Shield, ACBI7RS	H3269
Attic Radiation Shield, ACBI7RSA	H3270
Telescopic Attic Radiation Shield, ACBI7RST	H3271
Insulated Wall Radiation Shield 30, AC10RSMI30	H3272
Storm Collar, AC10FC	H3278
Note: ACBI Chimney is Not recommended at elevations above 4000 feet or in cold climates where temperatures are likely to fall below 32° F (0° C).	

VILLA VISTA™ COMPONENTS LISTS

Secure Temp™ ASHT 1" - High Temperature Insulated Stainless Steel Chimney System (7" ID and 11" OD)	
Description	Cat./ Part No.
Lengths and Misc. Chimney Components	
Length 8", 7L8	7L8
Length 12", 7L12	7L12
Length 18", 7L18	7L18
Length 24", XL24	7L24
Length 36", 7L36	7L36
Length 48", 7L48	7L48
Adjustable Length 12", 7" Dia., 7LA	7LA
15° Elbow, 7L15	7E15
30° Elbow, 7L30	7E30
Rain Termination Cap, 7CC	7CC
Wall Band	BM
Supports	
Offset Support, SO	SO
Roof / Floor Support, ST	ST
Roof Brace, BS2	BS2
Roof Flashings	
Flat Roof Flashing, 7FR	7FR
Roof Flashing, Adjustable (5° to 30°), 7FAR	7FAR
Roof Flashing, Adjustable (30° to 45°), 7FBR	7FBR
Storm Collar, 7FC	7FC
Firestops	
Firestop, 7BF	7BF
Radiation Shield, 7RS	7RS
Insulated Attic Radiation Shield, 7RSA	7RSA
Insulated Wall Radiation Shield, 7RSM	7RSM
Insulated Wall Radiation Shield 30° 7RSMI30	7RSMI30

TUBINOX (or PROJET SS) Chimney For Relining a Masonry Chimney, 7" Diameter <i>Listed to ULC-S635M, JL-1777 and ULC-S640M at 2100° F</i>	
Description	Cat./ Part No.
Length 6", 7LL6	7LL6
Length 12", 7LL12	7LL12
Length 24", 7LL24	7LL24
Length 36", 7LL36	7LL36
Length 48", 7LL48	7LL48
Adjustable Length (7" to 11"), 7L7A	7L7A
Split Base Tee, 7LT	7LT
Tee Cap, 7TCS	7TCS
Twist Lock Tee Cap, 7LTC	7LTC
Elbow 30°, 7LE30	7LE30
Elbow 45°, 7LE45	7LE45
Elbow 90°, 7LE90	7LE90
Rain Termination Cap (regular), 7LCS	7LCS
Rain Termination Cap (deluxe), 7LCC	7LCC
Supports	
Top Support, 7LST	7LST
Support Assembly, 7LSA	7LSA
Interior Support, 7LSB	7LSB
Adaptor Flexible Pipe (male), 7LAAM	7LAAM
Adaptor Flexible Pipe (female), 7LAAF	7LAAF
Stainless Steel Flex - 5 Ft. Long, 7LLFLEX	7LLFLEX
Adjustable Insulated Wall Radiation Shield 6" to 12", 7LRSMI	7LRSMI
Adaptors to Masonry Chimney	
Masonry Chimney Adaptor, 45°, BISPMA, CANADA ONLY	BISPMA
30° Adaptor for Masonry Chimney, BISPMA30	BISPMA30

VILLA VISTA™ COMPONENTS LISTS

Replacement Parts	
Description	Cat. No.
Back Refractory	H3301
Right Side Refractory	H3302
Left Side Refractory	H3303
Bottom Refractory	H3304
Ash Lip	H3300
Wooden Door Handle	H3305
Wooden Handle By-pass	H3306
Ceramic Glass Panel	H3307
Hinge Kit	PR-SR2395P
Secondary Air Tube (rear)	H3308
Catalyst Air Tube (front)	H3309
Cast-iron Log Supports (2)	H3310
Log Retainer Bar	H3311
Catalytic Combustor	H3298
Catalytic Combustor Stainless Steel Casing	H3299
Touch-up Paint, Aerosol, Black Metallic SBMB6309	70K99

SPECIFICATIONS

Cat. No.	Model
H3250	VILLA VISTA

Product Reference Information	
Weight	385 lbs
Height	45"
Width	38"
Depth	24-1/2"
Chimney Weight ASHT+ (7" dia)	7.8 lb/ft.
Chimney Weight ACBI (8" dia.)	3.75 lb/ft.

CLEARANCE TO COMBUSTIBLES

The following clearances meet the minimum requirements for a safe installation;

Side wall: 24" (610 mm) measured from the doors edge

Ceiling: 6' 8" (2032 mm) measured from the base of the fireplace

Fireplace enclosure:

Bottom: 0"

Side: 0" to spacer

Back: 0" to spacer

Top: Do not fill the space above the fireplace with any material
(7 feet measured from the base of the fireplace)

Chimney:

ASHT+: 2" (50mm)

ACBI: 1" (25mm) at ceiling/roof level and 2" (50mm) through a wall

Mantel: 54" (1372 mm) measured from the base of the fireplace or 48" (1219) when installed with Clean Face Panel option (BPCF) and Gravity Air Kit

WARRANTY

Your fireplace is covered by a limited warranty. Please read the warranty to be familiar with its coverage.

Retain this manual. File it with your other documents for future reference.

PRODUCT REFERENCE INFORMATION

We recommend that you record the following important information about your fireplace. Please contact your Lennox Hearth Products dealer for any questions or concerns. For the number of your nearest Lennox Hearth Products dealer, please call 1-800-9-LENNOX.

REPLACEMENT PARTS

See **Page 25** for a complete replacement parts list. Use only parts supplied from the manufacturer.

Normally, all parts should be ordered through your Lennox Hearth Products distributor or dealer. Parts will be shipped at prevailing prices at time of order.

When ordering repair parts, always give the following information:

1. The model number of the appliance.
2. The serial number of the appliance.
3. The part number.
4. The description of the part.
5. The quantity required.
6. The installation date of the appliance.

If you encounter any problems or have any questions concerning the installation or application of this system, please contact your dealer.

LENNOX HEARTH PRODUCTS

1110 West Taft Avenue
Orange, CA 92865

Visit us at www.Lennox.com

Your Fireplace's Model Number _____
Your Fireplace's Serial Number _____
The Date On Which Your Fireplace Was Installed _____
Your Dealer's Name _____
Your Dealer's Phone Number _____



We recommend that our woodburning hearth products be installed and serviced by professionals who are certified in the U.S. by the National Fireplace Institute® (NFI) as NFI Woodburning Specialists or who are certified in Canada by Wood Energy Technical Training (WETT).



Nous recommandons que nos p eles   bois soient install es et que l'entretien soit effectu e par des professionnels certifi es, aux Etats-Unis par le National Fireplace Institute® (NFI) et au Canada, par le Wood Energy Technical Training (WETT).



Lennox Hearth Products reserves the right to make changes at any time, without notice, in design, materials, specifications, prices and also to discontinue colors, styles and products. Consult your local distributor for fireplace code information.

LENNOX
HEARTH PRODUCTS