

MACM Series

MACM-250

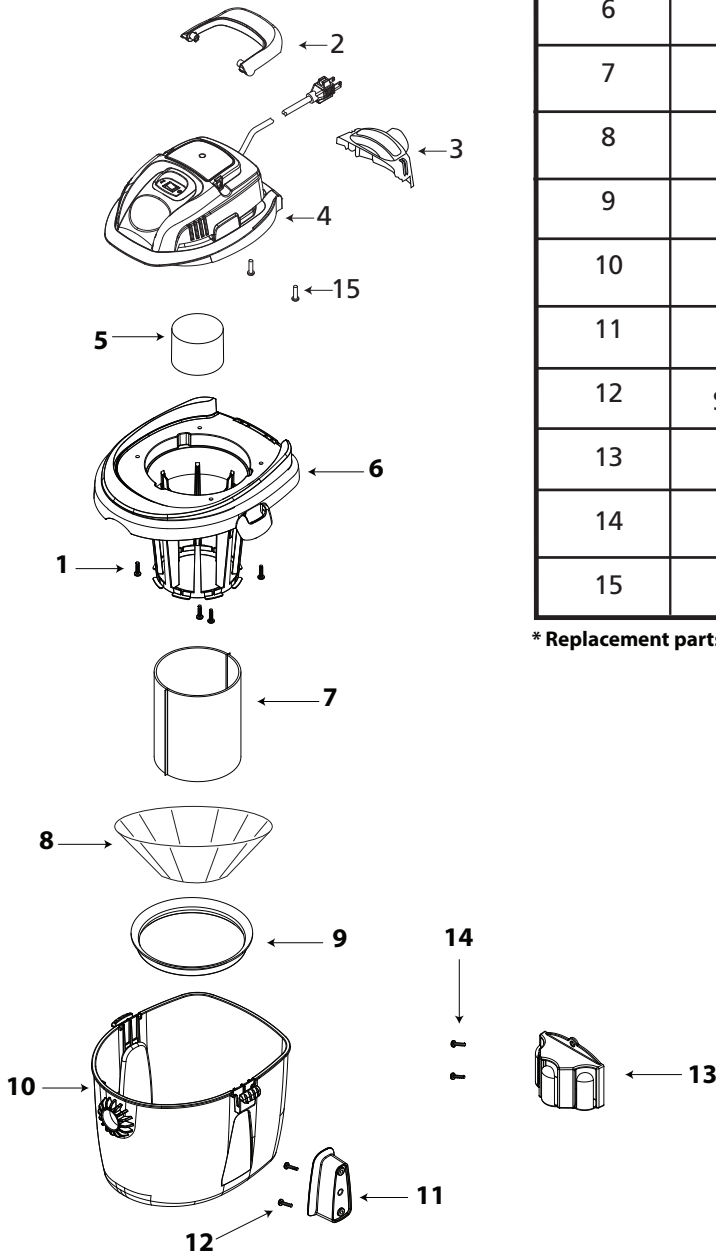

ITEM	DESCRIPTION	PART NO.
1	Screw 10 X 3/4" Trilobe, Twin Lead	1517699
2	Handle	4513500
3	Blower Port	7418950
4	Power Unit Assembly	8400097
5	Float	3545000
6	Lid Cage Assembly	4511101
7	Foam Sleeve	90585
8	Reusable Dry Filter	90107
9	Filter Ring	3006500
10	Tank Assembly	1098797
11	Wall Bracket	4510900
12	Screw #10 x 1 SLT Pan HD Type AB	1501199
13	Tool Holder	3159010
14	Screw 10 x 3/4" SL Hex Head	1503999
15	Screw #10 x 5/8 Hex	1505499

* Replacement parts may differ from original equipment.