

This Owner's Manual is provided and hosted by [Appliance Factory Parts](http://www.appliancefactoryparts.com).



LENNOX HEARTH C310 Owner's Manual

[Shop genuine replacement parts for LENNOX HEARTH
C310](#)

REPLACEMENT PARTS - MODEL C310

Door Parts

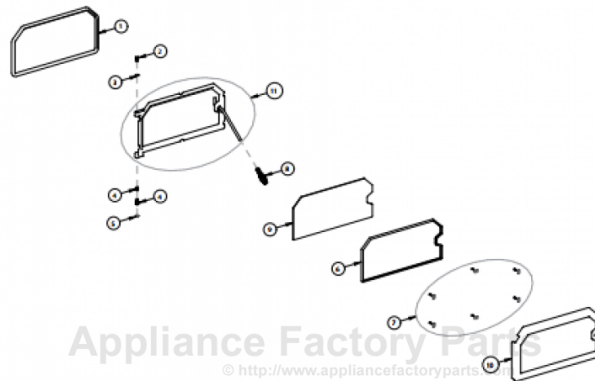

Blower Parts

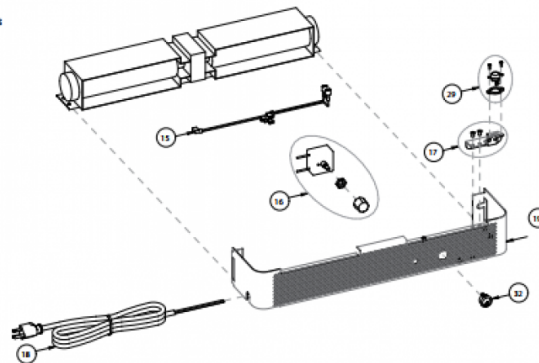

[Find Your LENNOX HEARTH Fireplace Parts - Select From 237 Models](#)

----- Manual continues below -----



**EPA Certified
Wood-Burning
Fireplace Insert**

**Save These Instructions
For Future Reference**

P/N 775,213M, Rev. B, 02/2010



**Wood Fireplace Insert
Model Canyon™ C310**

A French manual is available upon request. Order P/N 775,213CF.

Ce manuel d'installation est disponible en français, simplement en faire la demande. Numéro de la pièce 775,213CF.



These appliances must be properly installed and operated in order to prevent the possibility of a house fire. Please read this entire installation and operation manual before installing and using your wood stove. Failure to follow these instructions could result in property damage, bodily injury or even death. Contact your local building or fire officials to obtain a permit and information on any installation requirements and inspection requirements in your area.

**NATIONAL
FIREPLACE
INSTITUTE**
NFI
CERTIFIED
www.nficertified.org

We recommend that our woodburning hearth products be installed and serviced by professionals who are certified in the U.S. by the National Fireplace Institute® (NFI) as NFI Woodburning Specialists or who are certified in Canada by Wood Energy Technical Training (WETT).

 Wood Energy
Technical Training
www.wettinc.ca

Tested &
Listed By  Portland
Oregon USA
OMNI-Test Laboratories, Inc.
Report No. 050-S-10b-4

	⚠ WARNINGS <ul style="list-style-type: none">• Hot! Do not touch! The glass and surfaces of this appliance will be hot during operation and will retain heat for a while after shutting off the appliance. Severe burns may result.• Carefully supervise children in the same room as appliance.
	

CONGRATULATIONS!

When you purchased your new wood-burning fireplace insert, you joined the ranks of thousands of individuals whose answer to their home heating needs reflects their concern for aesthetics, efficiency and our environment. We extend our continued support to help you achieve the maximum benefit and enjoyment available from your new wood-burning fireplace insert.

Thank you for selecting a Lennox Hearth Products wood-burning fireplace insert as the answer to your home heating needs.

TABLE OF CONTENTS

Using This Manual	2
Important Safety Information	3
Testing Information	4
Draft Requirements	4
Selecting the Proper Venting System	4
Negative Pressure Warning	5
Creosote	5
Ash Disposal	5
Fuel	5
Burn-In Period	5
Paint Curing	5
Brick Installation	6
Required Clearances	7
Hearth Protection	8
Chimney Requirements	9
Installation Procedures-Masonry Chimney	9

Positive Flue Connection	10
Insert Pre-Installation Preparation	11
Chimney Liner Installation	11
Installing the Insert	11
Post Installation Checks	11
Operating Hints	12
Starting and Maintaining a Fire	12
Blower Operation (optional kit)	13
Operating Techniques and Hints	14
Getting the Most Out of Your Stove	14
Maximizing Your Stove's Overall Efficiency	14
Achieving Clean, Long Burns	14
Maintenance	15
Clean Glass	15
Troubleshooting	16
Do's and Don'ts	17
Replacement Parts List	18-20
Accessories	21
Safety / Listing Labels	22
Product Reference Information	24

USING THIS MANUAL

Please read and carefully follow all of the instructions found in this manual. Please pay special attention to the safety instructions provided in this manual.

PRODUCT IS SUBJECT TO CHANGE WITHOUT NOTICE

IMPORTANT SAFETY AND WARNING INFORMATION

READ THIS MANUAL IN ITS ENTIRETY AND UNDERSTAND THESE RULES TO FOLLOW FOR SAFETY.

1. When this room heater is not properly installed, a house fire may result. To reduce the risk of fire, follow the installation instructions. Contact local building or fire officials about restrictions and installation inspection requirements in your area.
2. Wear gloves during installation to avoid injury from sharp edges on the fireplace insert and/or its parts.
3. This unit is designed and engineered to burn only dry, well-seasoned wood. Burning wet wood will greatly reduce your fireplace inserts efficiency, produce excessive amounts of smoke and can cause dangerous chimney fires due to creosote build-up.
4. Before opening the door, **the draft control must be fully open to avoid possible combustion flash** (ignition of hot volatile gases as the door is opened).
5. Never use gasoline, gasoline-type lantern fuel, kerosene, charcoal lighter fluid, or similar liquids to start or 'freshen up' a fire in this heater. Keep all such liquids well away from the heater while it is in use.
6. While burning, fuel utilizes oxygen from the air in the room. Be sure to allow an adequate amount of fresh air into the room where the fireplace insert is burning.
7. The outside surface of the fireplace insert will be hot while burning properly and can set items like clothing and curtains on fire. Keep furnishings and other combustible materials away from the fireplace insert. Using the heat from the fireplace insert to dry wet clothing can be hazardous if clothes are placed too near the surface of the fireplace insert.
8. Hot while in operation. Keep children, clothing furnishings and combustible material a considerable distance away. Contact may cause skin burns. Do not allow children to play near the fireplace insert without close supervision. Do not touch the fireplace insert while it is burning. Use extreme caution while the unit is in use. Surface temperatures become dangerously hot and can cause serious burns.
9. Do not allow anyone to operate the fireplace insert who is not familiar with the operating instructions.
10. Attempts to achieve heat output rates that exceed fireplace insert design specifications can result in permanent damage to the fireplace insert. Never leave your fireplace insert unattended on high burn rates. This may cause overfiring. Overfiring the fireplace insert may cause a house fire. If the fireplace insert glows, you are overfiring.
11. Keep a water hose or hand-operated fire extinguisher close for safety.
12. **Smoke Detectors** - Since there are always several potential sources of fire in any home, we recommend installing smoke detectors. If possible, install the smoke detector in a hallway adjacent to the room (to reduce the possibility of occasional false activation from the heat produced by the insert). If your local code requires a smoke detector be installed within the same room, you must follow the requirements of your local code. Check with your local building department for requirements in your area.
13. Inspect your chimney at least once a month during the burning season to check for soot and creosote accumulations. Any accumulations over 1/4" thick should be removed by a professional chimney sweep. Do not attempt to burn out heavy creosote accumulations with a hot fire. If large accumulations are occurring, review your burning procedures.
14. If a creosote fire should develop, the fire department should be called immediately and then attempts should be made to control the fire until assistance arrives. If a "runaway" fire should develop causing over-heating of the fireplace insert, the door and draft regulators should be closed immediately. The fire should die down once deprived of oxygen. After a severe chimney fire, the complete chimney system should be checked before further use.
15. **Do Not Use Grate Or Elevate Fire - Build Wood Fire Directly On Hearth** (firebrick). Do not use andirons or other methods of supporting the fuel.
16. Please read this entire manual before you install and use your new room heater. Failure to follow instructions may result in property damage, bodily injury, or even death.
17. Check all local building and safety codes before installation. The installation instructions and appropriate code requirements must be followed exactly and without compromise. In the absence of local codes the following standards and codes must be followed.
18. In the U.S.A, install in accordance with the National Fire Protection Association's Code, NFPA 211, Standards for Chimneys, Fireplaces, Vents and Solid-Fuel-Burning Appliances, or similar regulations, may apply to the installation of a Solid-Fuel-Burning appliance in your area. In Canada, the guideline is established by the CSA Standard, CAN/CSA-B365-M93, Installation Code for Solid-Fuel-Burning Appliances and Equipment.
19. Do not connect to any air distribution duct or system.
20. **WARNING: BURNING IMPROPER FUEL (I.E. CHARCOAL) CAN RESULT IN CARBON MONOXIDE POISONING, WHICH MAY LEAD TO DEATH!**
21. **Carbon Monoxide Poisoning** – early signs of carbon monoxide poisoning resemble the flu with headaches, dizziness, or nausea. If you have these signs, get fresh air at once! Have the heater inspected by a qualified service technician. Some people are more affected by carbon monoxide than others. These include pregnant women, people with heart or lung disease or anemia, those under the influence of alcohol, and those at high altitudes.
22. Failure to use manufacturer provided parts, variations in techniques and construction materials or practices other than those described in this manual may create a fire hazard and void the limited warranty.
23. Do not make any make-shift compromises during installation. Any modification or alteration may result in damage to the appliance or dwelling and will void the warranty, certification and listings of this unit.
24. These appliances are designed as supplemental heaters. Therefore, it is advisable to have an alternate heat source when installed in a dwelling.
25. **Do Not Overfire – If Heater or Chimney Connector Glows, You Are Overfiring.**
26. **DO NOT CONNECT THIS UNIT TO A CHIMNEY FLUE SERVING ANOTHER APPLIANCE.**

TESTING INFORMATION

This manual describes the installation and operation of the Canyon™ C310 non-catalytic wood heaters. These heaters meet the U.S. Environmental Protection Agency's emissions limits for wood heaters sold on or after July 1, 1990. This heater has been developed, tested and constructed in accordance with the requirements of UL 1482, ULC S628 and HUD standards and is listed by OMNI Test Laboratories, Portland, OR. It has been approved for residential and alcove installations.

DRAFT REQUIREMENTS

Your wood fireplace insert is dependent upon a properly functioning chimney for optimum performance. It is a high efficiency appliance that loses much less heat up the chimney than older appliances and fireplaces. For this reason it is important to match the fireplace insert to the chimney. The chimney has two functions:

1. It draws combustion air into the appliance (without air, no fuel will burn) and
2. It exhausts combustion by-products. Your new Country™ Collection fireplace insert is what is known as a "natural draft" appliance.

The appliance depends solely on the natural draft of the chimney system to draw combustion air into the unit. Draft is the force that moves air from the appliance up into the chimney. The amount of draft in your chimney depends on the length of the chimney, local geography, nearby obstructions and other factors. Too much draft may cause excessive temperatures in the appliance (overfiring). Slow or inadequate draft equals poor combustion and possible smoking problems. The following are some conditions that may contribute to poor chimney draft:

1. A chimney too large for your appliance.
2. A chimney with not enough height to produce adequate draft.
3. A chimney with excessive height (this may allow exhaust to cool too much before exiting, which will stall the rate the exhaust exits).
4. Offsets in the venting system are too restrictive (see *Chimney Guidelines*).

Inadequate draft will cause the appliance to leak smoke into the room through the fireplace insert and the chimney connector joints.

Excessive draft may cause an uncontrollable burn or a glowing red fireplace insert or chimney part.

Overfiring Damage - If the heater or chimney connector glows, you are overfiring. Other symptoms may include: Cracking, warping or burning out of components, plated doors may turn color, stove glass may develop a haze, which will not come off with cleaning.

Overfiring of a fireplace insert is a condition where excessive temperatures are reached, beyond the design capabilities of the appliance. The damage that occurs from overfiring is not covered under the manufacturer's limited warranty.

Also see *Troubleshooting* on **Page 16**.

SELECTING THE PROPER VENTING SYSTEM

The appliance is merely one component of a larger system. The other equally important component is the venting system. This is necessary for achieving the required flow of combustion air to the fire chamber and for safely removing unwanted combustion by-products from the appliance. If the venting system's design does not promote these ends, the system may not function properly. Poorly functioning venting systems may create performance problems as well as be a safety hazard. **A draft test should**

read greater than .04' W.C. (inches water column) and less than .08" W.C. As per NFPA-211 standard (see paragraph below), the installer must take into account all variables within the installation and install the appliance in such a manner that satisfies the draft requirements of the appliance. See *Chimney Guidelines* below to assist you in selecting the proper venting system for your installation.

American National Standards Institute ANSI/NFPA 211, Standard for Chimneys, Fireplaces, Vents, and Solid Fuel-Burning Appliances

- **See Draft Section:** A chimney or vent shall be so designed and constructed to develop a flow sufficient to completely remove all flue and vent gases to the outside atmosphere. The venting system shall satisfy the draft requirements of the connected appliance in accordance with the manufacturer's instructions.

Chimney Guidelines:

- This appliance requires approximately 12 feet minimum of "effective draw" provided by the venting system. As a rule of thumb, every 90 degree total direction change in the venting will result in a loss of approximately 5 feet of "effective draw." Example: If two 45 degree offsets are used, subtract 5 feet from the actual vertical vent height to determine your "effective draw." In this case if you had 14 feet of vertical vent, the effective draw would only be approximately 9 feet (14 ft. - 5 ft. = 9 ft.), therefore it may be necessary to add additional height to the venting system.
- If the venting system is all vertical and the total vent length above the flue outlet exceeds 14 feet, it is recommended that the 8" to 6" pipe reducer is used (cat. no. 71134) and a 6" venting system be installed. At higher elevations, this may not be necessary.
- In well insulated and weather tight homes, it may be difficult to establish a good draft up your chimney. The poor draft is caused by a shortage of air in the house (see *Negative Pressure Warning* on **Page 5**).

Chimney Height Requirements

The chimney must extend 3' (.92m) above the level of roof penetration and a minimum of 2' (.61m) higher than any roof surface within 10' (3m) (see below). Check with your local building officials for additional requirements for your area.

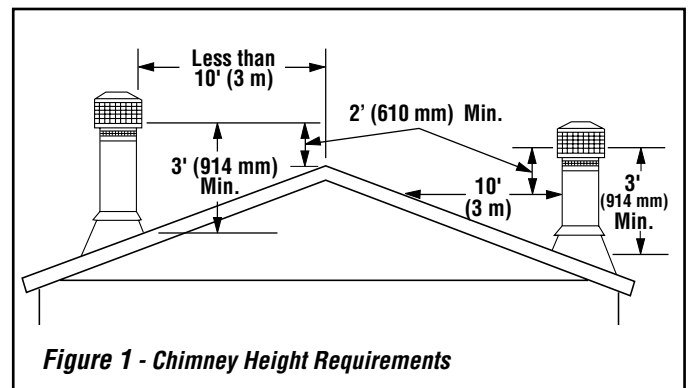

Figure 1 - Chimney Height Requirements

To pass inspection in nearly any jurisdiction, the chimney must meet both safety and exhaust flow requirements. The (3' by) 2' by 10' rule applies to both masonry and factory-built chimneys.

*** Ref. USA - National Standard, NFPA 211-latest edition and Canada National Standard CSA B365-01-latest edition. Vents installed with a listed cap shall terminate in accordance with the terms of the cap's listings.**

NEGATIVE PRESSURE WARNING

This appliance is not designed to be operated in a negative pressure. In very airtight homes with large kitchen exhaust fans, furnace cold air returns, fresh air exchange systems and any other air system in close proximity to the heating appliance may create a negative pressure in the same room as the heating appliance. This can create dangerous back drafting of the stove and chimney joints, drawing combustion by-products into the home. Be sure your home has adequate makeup air to eliminate negative pressures caused by the above-mentioned sources. Outside air connected to the appliance probably will not resolve such a problem as the stove or fireplace insert is not the source of negative pressure. Lennox Hearth Products accepts no liability for damages resulting from negative pressures described above.

Ventilation Requirements - Provide adequate air for combustion. The fresh air requirements of this appliance must be met within the space where it will be installed. Ventilation is essential when using a Solid-Fuel-Burning heater. In well insulated and weather tight homes, it may be difficult to establish a good draft up the chimney (caused by a shortage of air in the home). The lack of air is caused by many common household appliances which exhaust air from the home (such as a furnace, heat pump, air conditioner, clothes dryer, exhaust fans, fireplaces, and other fuel burning appliances). Also, the combustion process of this heater uses oxygen from inside the dwelling. If the available fresh air delivery in the dwelling is insufficient to support the demands of these appliances, problems can result (i.e. excessive negative pressure can develop in the dwelling which will affect the rate at which this appliance can draft thus resulting in performance problems. To correct this problem it may help to open a window (preferably on the windward side of the house) or install an optional outside air kit.

CREOSOTE, FORMATION AND NEED FOR REMOVAL

When wood is burned slowly, it produces tar and other organic vapors, which combine with expelled moisture to form creosote. The creosote vapors condense in the relatively cool chimney flue of a slow-burning fire. As a result, creosote residue accumulates on the flue lining. When ignited, this creosote makes an extremely hot fire. The chimney and chimney connector should be inspected at least once monthly during the heating season to determine if a creosote buildup has occurred. If creosote has accumulated, it should be removed to reduce the risk of a chimney fire.

ASH DISPOSAL

Ashes should be scooped out of a cool stove with a small metal shovel. Ashes should be placed in a metal container with a tight fitting lid. The closed container of ashes should be placed on a non-combustible floor or on the ground, well away from all combustible materials, pending final disposal. If the ashes are disposed of by burial in soil or otherwise locally dispersed, they should be retained in the closed container until all the cinders have thoroughly cooled. Ashes can ignite up to 72 hours after removal from the stove.

FUEL

This unit is designed and engineered to burn, dry, well-seasoned wood only.

Dry, seasoned wood is that which has been cut, split and allowed to dry under a covered area where air is free to flow and circulate under and around the wood (not under a tarp or plastic). Make sure wood is not stacked directly on the ground, it may absorb moisture from the ground. It should be allowed to dry in these conditions for a minimum of six months, preferably one year or more. **IT MUST BE UNDERSTOOD THAT WOOD CANNOT BE LEFT IN ANY KIND OF WET OR DAMP AREA OR IT WILL NEVER BECOME COMPLETELY SEASONED.** Your fireplace insert will not operate at the level that it is meant to unless you use seasoned, dry wood. Do not burn driftwood or wood that has been in salt water, doing so will void your warranty. Do not burn treated wood, coal, garbage, cardboard, solvents, or colored paper. Burning treated wood, garbage, solvents, or colored paper may result in the release of toxic fumes. This type of burning will also void your warranty.

PAINT CURING

If your fireplace insert has a Gold or Nickel-Plated Door, be sure to clean it with household type glass cleaner and a very soft cloth to remove any fingerprints and residues prior to the first fire and before any fire if the gold has been handled or soiled. Do not close the door tightly during the "Burn-In Period." Also, open the door frequently (every 5-10 minutes) to keep the gasket from adhering to the curing paint. Ventilate the house well during these first firings as the paint gives off carbon dioxide and unpleasant odors. It is recommended that persons sensitive to an imbalance in the indoor air quality avoid the fireplace insert during the curing process.

Your new Canyon™ C310 is painted with a high temperature paint that cures during the first few firings. We recommend that you put your stove through a regimen of three burns. The first two should last for 20 minutes each at 250 degrees (the stove should be allowed to cool completely between each burn). The third should be a burn of at least 450 degrees F. for 45-60 minutes. The paint will become soft, gummy and emit non-toxic smoke during these burns. After the stove cools down for the third time, the paint will harden. **DO NOT BUILD A LARGE ROARING FIRE UNTIL THIS CURING EFFECT IS COMPLETE OR YOU MAY DAMAGE THE FINISH OF YOUR STOVE.** Spray can touch-ups should be done only with a high temperature stove paint (cat. no. 70K99), available from all Lennox Hearth Products dealers.

BURN-IN PERIOD

Please be patient with the heat output of your fireplace insert for the first few weeks. The steel will go through a curing process that eliminates moisture, which is deep in the steel and firebrick. This moisture will reduce initial heat output of your fireplace insert and may make it difficult to start. After you have broken in the paint on the fireplace insert it will be necessary to build hot fires to thoroughly remove the moisture from the appliance. Running the fireplace insert with the draft fully open for 1 to 1-1/2 hours after starting and adding generous amounts of fuel during the first week or two should complete the curing process. We recommend the use of a thermometer attached to the fireplace insert top or chimney. Temperatures on the connector pipe should run in the 250-600 degree range. **(DO NOT OVER FIRE THE STOVE DURING THIS PROCESS. IF THE STOVE OR CHIMNEY BECOMES RED, REDUCE THE AMOUNT OF AIR ENTERING THE STOVE IMMEDIATELY).**

BRICK INSTALLATION

CANYON™ C310

CAUTION: Wear gloves during brick installation in case of sharp edges behind the stove.

Note: Installation of the baffle boards and baffle blankets are easier when you can still access the flue outlet, (before connecting the flue vent). **Be sure the baffle blankets are placed flat on the baffle boards so as not to block exhaust flow to the flue.** Use a ruler or a piece of kindling to reach over the baffle blanket to be sure it is completely flat on top of the baffle boards.

1. Install bricks #1-34 in the numbered sequence as shown in **Figure 2** (**Note:** Bricks 22-25 lean up against the lower air channel and butt against bricks 17-21 on the bottom of the stove).
2. Next, you will install the baffle boards. All 4 baffle boards included are the same size (15-1/2" X 6-3/16"). You will start by installing the boards in the center part of the unit on top of the secondary tubes to each side of the baffle support with the 15-1/2" side of the baffle board going from the front to back of the unit. Once you have the first two boards installed slide the board to the left side of the baffle support all the way to the left and rear of the unit. You will slide the board to the right side of the secondary support to the right and rear of the unit. Next you will install the two remaining boards where you originally installed the first two boards on each side of the baffle support and pushed against the rear of the unit. The stainless steel support hanger should be centered left to right between the sets of baffle boards and placed as shown in **Figure 4**.
3. Also included with the unit are two 17" x 12-7/16" x 1" thick baffle blankets. Install each blanket above the baffle board to each side of the secondary support with the 17" side of the blanket from front to rear of the unit. Make sure that the baffle blankets are to the full rear of the unit.

CAUTION: Make sure that the baffle blankets are centered side to side and rest flat on the baffle boards and do not project beyond the front edge of the baffle boards.

WARNING: IF THE BRICKS ARE NOT INSTALLED EXACTLY AS SHOWN, THEY COULD FALL OUT OF PLACE DURING REFUELING OR BURNING OF THE STOVE, CAUSING SERIOUS INJURY.

Canyon™ C310 Brick Sizes
(see Figures on this page)

Brick Sizes	
A	3-7/8" X 8-3/4"
B	6-1/2" X 4-1/2"
C	3-1/2" X 9"
D	1-1/2" X 4-1/2"
E	3-7/8" X 9"
F	4-1/2" X 9"
H	3-1/2" X 4-1/2"
K	3" X 7"
M	4-1/2" X 4-1/2"

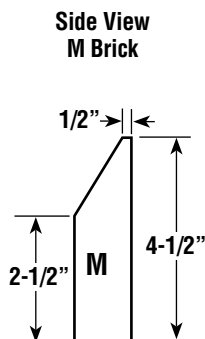

Firebox Brick Layout

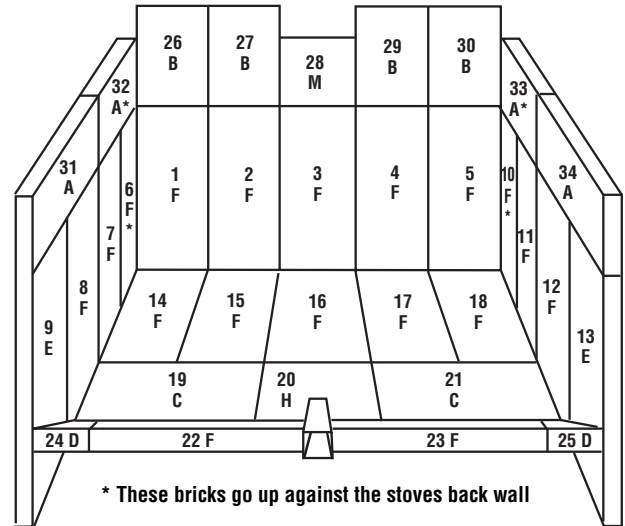

Figure 2

Baffle Insulation Parts

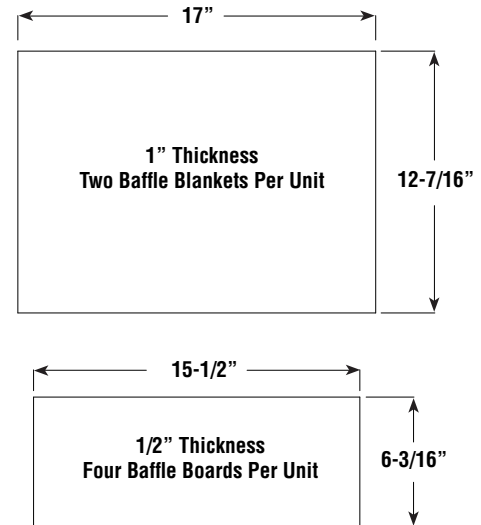

Figure 3

Side Cut-A-Way View of Firebox

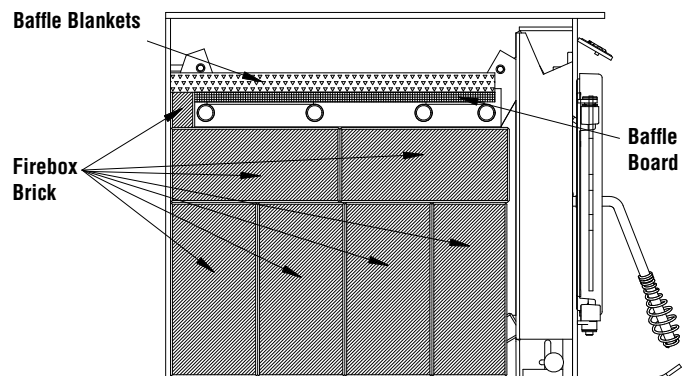

Figure 4

NOTE: DIAGRAMS & ILLUSTRATIONS ARE NOT TO SCALE.

REQUIRED CLEARANCES

WARNING: BE ABSOLUTELY SURE THE DISTANCE BETWEEN THE HEATER AND THE SURFACE OF ANY COMBUSTIBLE CONSTRUCTION IS NOT LESS THAN SHOWN ON THIS PAGE.

Model	*A	*B	*C	*D	E(1)
C310	USA-30" CAN-787mm	USA-20" CAN-584mm	20" 508mm	15" 381mm	8" 200mm
C310 with mantel and/or side shields	22" 559mm	12" 305mm	20" 508mm	8" 200mm	8" 200mm

Model	F (1)	G	H	J(2)	M
C310	24" 610mm	14-1/2" 368mm	22-1/2" 572mm	5-1/4" 133mm	50-1/2" 1283mm
C310 with mantel and/or side shields	24" 610mm	14-1/2" 368mm	22-1/2" 572mm	5-1/4" 133mm	42-1/2" 1080mm

* Reduced clearances may be available for A, B, C and D dimensions per NFPA 211 - latest edition, Standard for Chimneys, Fireplaces, Vents and Solid Fuel-Burning Appliances (in Canada CSA B365 - latest edition). See section on "Reduction of Appliance Clearance with Specified Forms of Protection."

** Side view of optional mantel deflector shown.

(1)Hearth extension reductions: 2" (51mm) reduction for 2" (51mm) raised hearth. (USA and Canada) 24" minimum hearth extension on all stoves as measured from the door opening of the unit (16" [406mm] minimum hearth extension on all inserts as measured from the door opening of the unit). Minimum distance of floor protection to the side = 8" (200mm). This is measured from the sides of the door opening in the USA and from the sides of the insert in Canada.

(2)J = Maximum lintel depth without flue offset or smoke deflector.

C310	Masonry Fireplace UBC Chapter 37
Depth Min.	14-3/4" (375mm)
Height Min. ①	22-3/4" (578mm)
Width Min.	30-1/2" (775mm)
Lintel Max. Depth ①	5-3/4" (146mm)

① Without use of adjustable offset box or smoke deflector

Table 1 - Fireplace Sizing

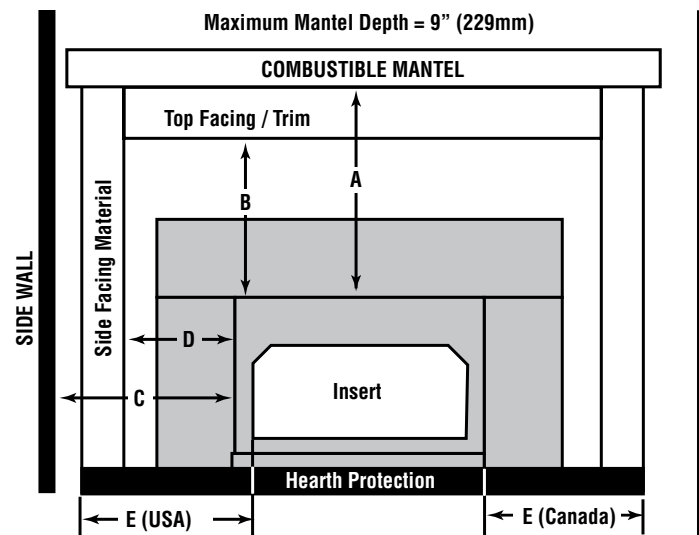

Figure 5

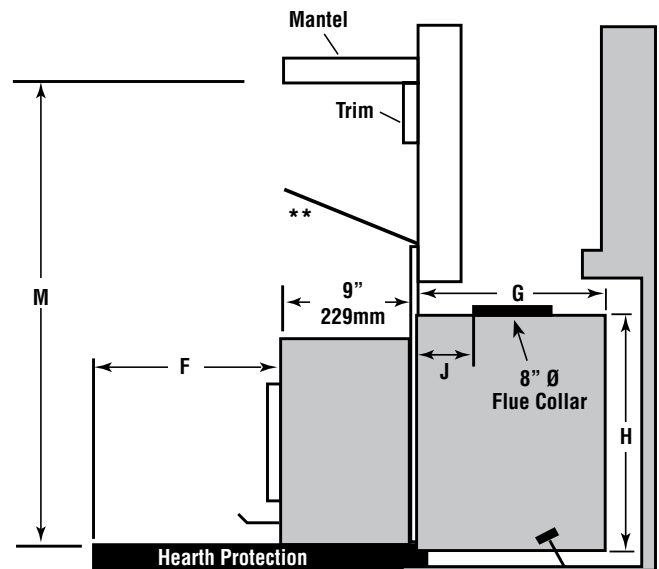

Figure 6

Note:

- Facing material that projects more than 3/4" (19mm) from the wall is considered a mantel or side wall.

HEARTH PROTECTION

The hearth and/or floor protection must be a thermally rated non-combustible hearth/floor protector meeting or exceeding a thermal rating of $k=.84$ or equivalent with a listed thickness of 3/4" (19mm) minimum in USA and Canada. The covering must extend 24" (610mm) in front of the heater and 8" (200mm) to either side (measured from door opening in the USA and measured from the side of the unit in Canada).

Using Alternate Material As Floor / Hearth Protection

The hearth extension or alternate material used as a floor/hearth protector must be constructed of a durable noncombustible material having an equal or better thermal conductivity value (lower k value) of $k = .84$ BTU/IN FT² HR °F or a thermal resistance that equals or exceeds $r = 1.19$ HR °F FT² IN/BTU with a minimum thickness of 3/4". With these values, determine the minimum thickness of the alternate material required using the formula(s) and shown in **Table 2**.

Note: Any noncombustible material having a minimum thickness of 3/4" (19 mm) whose k value is less than .84 or whose r value is more than 1.19 is acceptable. If the alternate material used has a higher k value or lower r value will require a greater thickness of the material used. In some cases, if the k value is less or the r value higher, a thinner material may be used.

Methods of determining floor protection equivalents:

To determine the thickness required for the alternate material when either the " k " value or " r " value is known, use either the **k formula** or **r formula**.

Example: If Micore 160 Mineral Fiber Board is to be used for the floor protection, how thick must this material be?

k_M = k value per inch of **alternate** material
 r_M = r value per inch of **alternate** material
 T_M = minimum thickness required for **alternate** material
 T_S = standard thickness of the **alternate** material

k_L = k value per inch of **listed** material
 r_L = r value per inch of **listed** material
 T_L = minimum thickness of **listed** material

Note: An asterisk "*" indicates, it is a value taken from **Table 2**.
Using the k formula:

Minimum thickness of alternate material (T_M)	=	k-value (per Inch) of alternate material (k_M) x k-value (per inch) of listed material (k_L)	x	Specified min. thickness of listed material (T_L)
T_M (inches)	=	$\frac{k_M}{*.84}$	x	T_L
T_M (inches)	=	$\frac{*.35}{*.84}$	x	.75"
.312 (inches)=		.417	x	.75"

Answer - The minimum required thickness of the Micore 160 is .312" therefore round up to nearest standard thickness available which is 3/8" (.375")

Using the r formula:

Minimum thickness of alternate material	=	r-value (per Inch) of listed material r-value (per inch) of alternate material	x	Specified min. thickness of listed material
T_M (inches)	=	$\frac{r_L}{r_M}$	x	T_L
T_M (inches)	=	$\frac{*1.19}{*2.86}$	x	.75"
.312 (inches)=		.416	x	.75"

Answer - The minimum required thickness of the Micore 160 is .312" therefore round up to nearest standard thickness available which is 3/8" (.375")

Listed Material			
	k (per inch)	r (per inch)	Listed Min. Thickness
Listed Material	.84 K_L	1.19 r_L	3/4" (.75") T_L
** Approved Alternate Materials for Floor/Hearth Protection			
Alternative Materials	Thermal Values		Minimum Thickness (rounded to nearest 1/8 inch)
	k (per inch) K_M	r (per inch) r_M	Min. Thickness T_M
Kaowool M Board	.47	2.13	.42" (1/2")
Micore 160™ U.S. Gypsum	.35	2.86	.31" (3/8")
Micore 300™ U.S. Gypsum	.46	2.17	.41" (1/2")
Durock™ Cement Board U.S. Gypsum	1.92	.52	1.71" (1-3/4")
Hardibacker™	1.95	.51	1.74" (1-3/4")
Hardibacker 500™	2.30	.43	2.05" (2-1/8")
Cultured Stone Hearth-stone™	2.82	.35	2.52" (2-5/8")
Wonderboard	3.23	.31	2.88" (3")
Super Firetemp M Johns-Manville	.61	1.64	.54" (5/8")
Super Firetemp L Johns-Manville	.54	1.85	.48" (1/2")
Face brick	9.00	.111	8.04" (8-1/8")
Common brick	5.00	.20	4.46" (4-1/2")
Cement mortar	5.00	.20	4.46" (4-1/2")
Ceramic tile	12.5	.08	11.16" (11-1/4")
Marble	~11	~.09	9.82" (9-7/8")

Table 2 - USA AND CANADA REQUIREMENTS

**** If the hearth extension material(s) that is intended to be used is NOT listed on Table 1, the material can still be used if the material(s) is noncombustible. However, the manufacturer of the material must provide either the listed k -value per inch or r -value per inch with listed thickness so that the minimum thickness required for the hearth can be calculated (per instructions here or as specified in the NFI Certification Manuals).**

Note: Also see NFI (National Fireplace Institute) Certification Manuals showing other acceptable calculation methods and acceptable alternate materials which can be used.

CHIMNEY REQUIREMENTS

The Canyon™ C310 inserts are approved for use in masonry fireplaces built to UBC Chapter 37 or equivalent with a minimum 30-1/2" (775) width opening at the front of the fireplace.

The Canyon™ C310 inserts may be installed using 6" chimney in vertical installations utilizing a 8" to 6" reducer (cat. # 71134) at the flue collar. If the venting system is all vertical and the total vent length above the flue outlet exceeds 14 feet, it is recommended that the 8" to 6" pipe reducer is used and a 6" venting system be installed.

Do not remove brick or mortar from masonry fireplace to accommodate insert. Approved with or without positive flue connection. Approved with minimum 6" (152 mm) diameter stainless steel listed reline system. Country Collection inserts are tested to UL 1482 / ULC S628 and listed by OMNI-Test Laboratories, Inc.; Portland, OR.

IMPORTANT NOTE: See *Draft Requirements* and *Selecting a Proper Venting System* on **Page 4** to assist you in choosing the proper venting system for your installation.

Remove and clean behind unit frequently, as creosote build up may occur rapidly.

INSTALLATION PROCEDURES - MASONRY CHIMNEY

Note: Although not required, a full-length stainless steel liner is recommended for optimum safety and performance. See your Lennox Hearth Products dealer for details.

Note: When installing your stove with a positive flue connection, be sure to leave the insulation off the surround panels (flanges) and leave a 1/4" (6 mm) airspace insulation off the surround panels and the facing of your fireplace.

1. **READ ENTIRE INSTALLATION INSTRUCTIONS.**
2. Check all **REQUIRED CLEARANCES** as specified in the previous section (**Page 7**) of this installation instruction booklet.
3. Wear gloves during installation in case of sharp edges on the stove and it's parts.
4. Open or remove the existing fireplace damper. Make sure the damper cannot fall closed.
5. Install the two 1/2" x 3" (13 mm x 76 mm) leveling bolts -heads up- a few turns in the leveling nuts on each side of the outer chamber of the insert at the lower rear corners.
6. Position the insert in the center of the fireplace opening and push it back until the surround brackets are approximately 2" (51 mm) away from the fireplace front.
7. Install the side surround panels and push the insert up snug against the fireplace face. Then with the location selected remove the surround panels and level the stove with the leveling bolts using a 3/4" (19 mm) socket, extensions (to reach the bolt head) and a ratchet.
8. Glue the insulation around the outer edge of both the top and side surround panels.
9. Install the surround panels loosely, align and tighten. Check for a tight fit against the fireplace.
10. Install the brick and baffle as per instructions on **Page 6**.

POSITIVE FLUE CONNECTION

A positive flue connection is providing a seal between the vent pipe or liner and the existing fireplace chimney for the purpose of preventing room air passage to the chimney cavity of the fireplace. There are different approved methods to achieve this. See *Direct Connect Positive Flue Connection* on this page.

When creating a positive flue connection, a positive flue connector ring kit is required (sold separately - see *Figure 7*). The connector ring kits (listed below) provide a means to directly attach rigid pipe or an flex pipe adaptor to the flue outlet.

71162 - 8" Positive Flue Connector Ring Kit
71163 - 8" to 6" Reducer w/ Positive Flue Connector

Install connector ring kits per instructions provided in kits

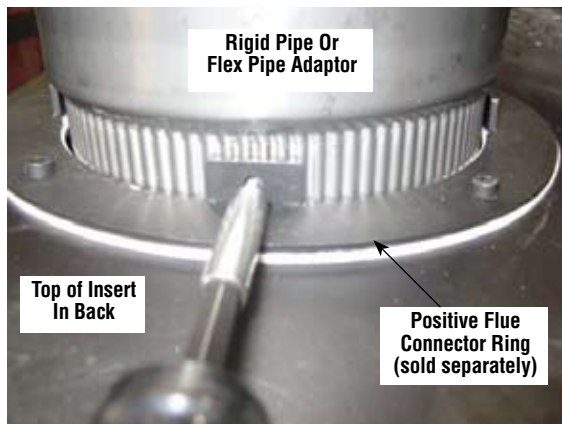

Figure 7 - Connector Ring Kit

Direct Connect Positive Flue Connection

Required in Canada

See the following instructions for approved methods of achieving a positive flue connection - See *Figure 8*.

A qualified installer should evaluate the existing fireplace to determine the best method for achieving a positive flue connection between the vent pipe or liner and the existing fireplace chimney. The most common method for achieving a positive flue connection in masonry fireplaces is to secure a seal-off plate (i.e. 22-gage sheet steel) in the fireplace throat using masonry screws. Other acceptable methods include packing noncombustible material (i.e. high temp fiberglass or ceramic insulation) around the vent pipe or using a flue adapter. Whatever "seal off" method is used, it must effectively seal the area to prevent room air passage to the chimney cavity of the fireplace.

Offset Boxes

Offsets can be handled using an offset box (it aligns flue outlet of insert with the fireplace flue (see *Figure 9*). Care should be used to ensure that this adjustable offset box is oriented so it does not angle down when positioned on the insert flue outlet (level or slightly up at the outbound end is recommended).

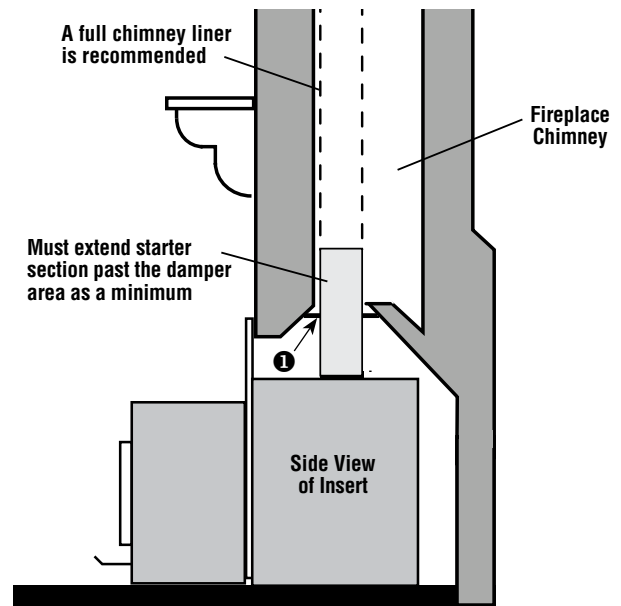

① A non-combustible seal is required at the damper area (to prevent dilution air from entering the chimney). See *Direct Connect Positive Flue Connection* on this page. A seal-off plate method is shown here.

Figure 8 - Positive Flue Connection

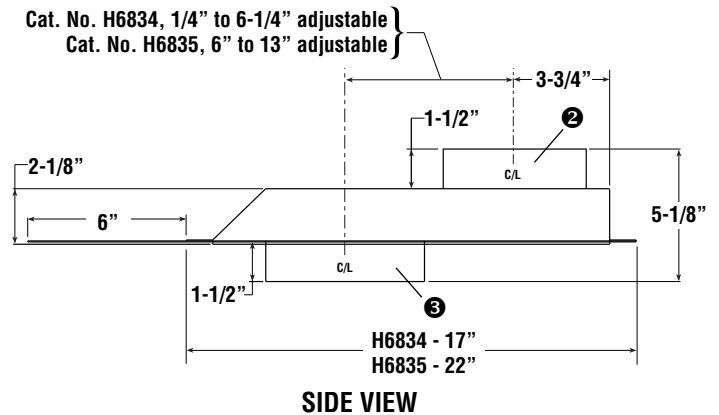

SIDE VIEW

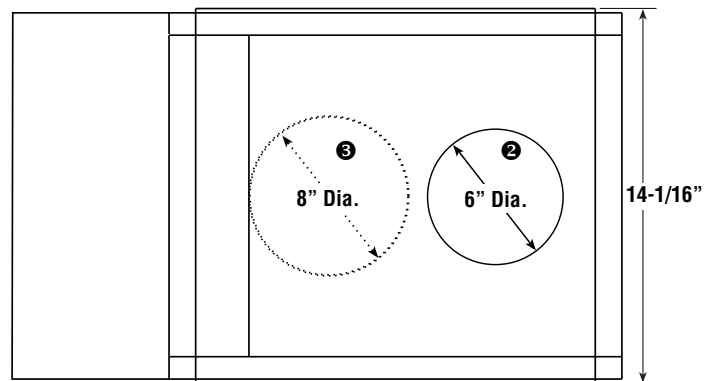

TOP VIEW

- ② Top 6" collar attaches to rigid pipe or flex liner.
- ③ Bottom 8" collar attaches to connector ring on insert flue outlet.

Figure 9 - Offset Box Dimensions

INSERT PRE-INSTALLATION PREPARATION

Install the two 3" (76 mm) long bolts (with the head up) through the nuts attached to the insert on the lower rear corner of each side. This will allow you to level the insert when placed into the fireplace. Measure from the front of the top surround mount to the center of the flue. Determine if there is an alignment problem in connecting a liner from the chimney to the insert's flue. If there is an alignment problem, connection can be made using a short piece of stainless flex or a stainless steel offset box (available from your dealer). Before installing the liner, make any attachment brackets or drill any holes in the liner, offset box, or insert. Once installed, it may be difficult or impossible to drill additional holes.

CHIMNEY LINER INSTALLATION

Remove the existing chimney cap and install a stainless steel liner into the chimney (if a special section has been used or drilled to attach to the insert, it must be the bottom piece). The next piece should be a dripless slip joint; followed by the rest of the chimney liner. Fasten the chimney at the top when it is positioned so that the slip joint will allow the lowest piece to slide up enough to clear the insert during installation. Insulate the top four to six feet between the liner and the chimney to prevent heat loss. Install the cap and flash if necessary to prevent water or creosote from entering the chimney's venting system.

From inside the fireplace firebox, attach any adapters or flue offsets and slide the liner up as far as necessary for the bottom piece to clear the insert during installation.

INSTALLING THE INSERT

Place the insert into the fireplace, making sure to center it side to side. Slide the insert in until the surround mounts are approximately 1/2" (13 mm) from the face of the fireplace where the surround panels cover.

Lower the chimney and make attachment to the insert. Level the stove by using a 3/4" socket and a long extension and adjusting the bolts on either side of the insert.

Install the side surround panels with the screws supplied. Push the insert in until there is approximately a 1/4" (6 mm) gap between the back of the surround panels and the face of the fireplace. Before installing the top surround panel, make sure all connections are tight and that no part of the insert or chimney is touching the firebox or chimney in the fireplace. There must be a minimum of 1" (25 mm) clearance between the stove and the zero clearance fireplace. Install the top surround panel.

If additional support is necessary, factory punched holes in the front corners of the bottom air chamber will accept leveling legs. Carefully measure the distance from the hearth protection to the bottom of the stove. Use 3/8" diameter bolts that are 1/2" (13 mm) longer than the distance just measured. Thread a nut onto the bolt approximately 1" (25 mm). Lift the stove slightly and insert a bolt into each hole and then thread the nut up the bolt until the front is securely supported. Install another nut onto the bolt through the air space in the stove and tighten securely. If desired an insert front support, Cat. No. H5296, is available to fill the space between the insert and the hearth protection.

Install the brick and baffle as per **Page 6**.

POST INSTALLATION CHECKS

1. Check that all chimney pipe joints are securely fastened.
2. Check that the heater is securely fastened to the floor (if applicable).
3. Make sure the intake vent has clear access to outside air (if applicable).
4. Make sure the outside air vent has been sealed properly to keep rodents out (if applicable).
5. Be sure all roof flashings are watertight (if applicable).
6. Be sure the stove is properly grounded (if applicable).

FOR YOUR OWN PROTECTION AND INSURANCE PURPOSES, HAVE YOUR CHIMNEY AND CONNECTOR PIPE INSTALLATION INSPECTED BY YOUR LOCAL BUILDING CODE AUTHORITY OR FIRE MARSHAL BEFORE STARTING A FIRE IN YOUR STOVE. NOTIFY YOUR INSURANCE COMPANY.

OPERATING HINTS

1. Burn only dry, well-seasoned wood for maximum heat output. In some states it is illegal to burn wet wood or anything other than clean, dry wood products.
2. Your fireplace insert is designed to operate with the door closed! Operate only with the door shut tightly at all times except when loading wood and possibly on start up to establish a draft. Never leave the unit unattended while the front door is slightly opened.
3. **DO NOT** hit or move the baffle board while loading wood. Occasionally check the baffle. Make sure the baffle blankets are always flush with the front of the baffle boards. Loading oversized logs may dislodge the baffle boards.
4. **CAUTION: THE DRAFT CONTROL MUST BE FULLY OPEN BEFORE OPENING THE DOOR TO AVOID POSSIBLE COMBUSTION FLASH!!** (Ignition of hot volatile gases as the door is opened).
5. Feeding excessive amounts of fuel to the stove should be avoided. It is important to supply it with sufficient draft and fuel to maintain a moderately hot fire. If, during overnight burns, heavy creosote deposits develop inside your stove and on the door, the draft is set too low - review your burning habits!

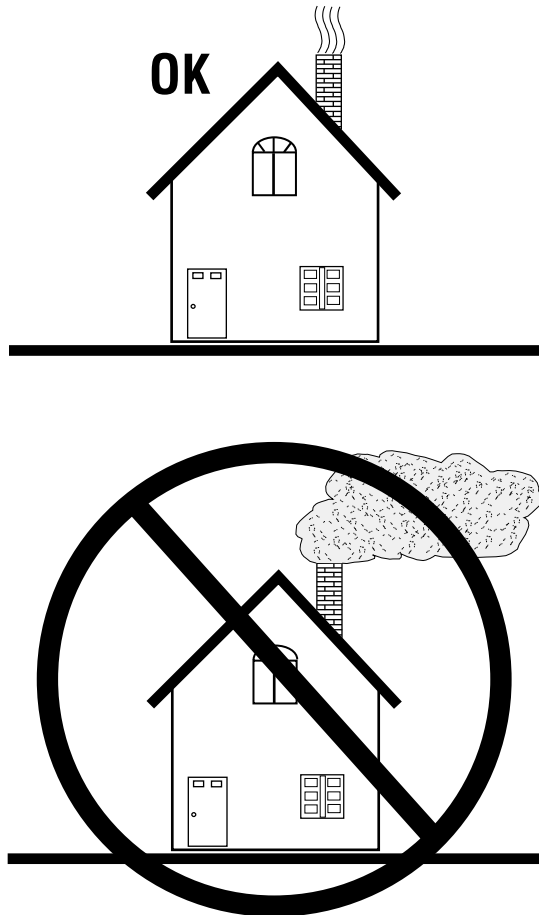

Figure 10

STARTING AND MAINTAINING A FIRE

Be sure to clean the Nickel or Gold Plated door with a household type glass cleaner and a very soft cloth to remove any fingerprints and residues prior to the first fire.

1. **NEVER USE FLAMMABLE LIQUIDS TO START OR REKINDLE A SOLID FUEL FIRE!!**
2. Fully open the primary draft control by pulling the 1" plastic knob out on the left side (lower front corner) until it stops (away from the stove). This control determines the amount of air entering the stove. Pushing it toward the stove reduces the burn rate in the firebox. For your convenience, the rod on this control is marked with four grooves to assist you in obtaining repeatable burn rates.
3. Place a small amount of crumpled paper in front of the firebox and cover it with a few pieces of kindling.
4. Light the paper and allow sufficient time for the kindling to become fully engulfed in flames. You will now close the wood units front door. (Your wood units front door may or may not need to be left slightly open during this start up process, this depends on the stove model and the amount of draft present. Do not leave the unit unattended while the front door is slightly open) Once kindling is burning well, larger pieces of wood may be added, then the door should be fully closed if there was the need to keep it slightly open during start up.

Do not operate the stove with the door open or ajar other than possibly during start up to create a draft (Do not leave the unit unattended while the front door is slightly open during start up). Operating the stove with the door open other than in initial start up if needed will produce extreme temperatures within the stove. Damage caused from over-firing is not covered under the manufacturers limited warranty.

5. For best results, use smaller pieces of wood to get the insert temperature very high before loading larger wood for sustained burns. If necessary, crack the door to allow ignition of the fuel charge. **Do not leave the unit unattended while the front door is slightly open.** Now you can add larger pieces of wood and after several minutes of high burn, set the left control for the desired heat output. Check the exhaust in about 15 to 20 minutes. Large amounts of smoke indicate an improper burn setting (either too high or too low). Adjust and recheck in 5 to 10 minutes.

BLOWER OPERATION

Blower Operation

The blower can be operated manually or automatically (blower will turn on when the insert is hot and turn off when the insert is cool).

The rocker switch on the control panel allows you to select between manual operation or automatic operation as follows (see **Figure 10**):

MANUAL OPERATION: Turn rocker switch to the manual position (up) and adjust rheostat knob to the desired speed. The blower will have to be manually turned "OFF" by rotating the rheostat knob counterclockwise until it clicks.

AUTO OPERATION: Turn rocker switch to the "AUTO" position and the rheostat to the ON position (rotate rheostat knob clockwise until it clicks). When the insert warms up, the blower will automatically turn on (adjust rheostat knob to the desired speed setting). When the insert cools down, the blower will automatically turn off.

Rheostat Operation - The highest blower speed is obtained by turning the rheostat knob clockwise until it clicks "ON", then rotate towards "HIGH" to increase blower speed. Rotate the knob clockwise for a lower speed. To turn off, continue to rotate the knob counterclockwise until it clicks "OFF."

Blower Operation Guidelines

While in auto operation mode, the blower will turn off and on based on the temperature of the stove. Auto operation ensures there is sufficient heat build-up to warm the air being moved by the blower before the blower is turned on. Likewise, when the stove cools off, the blower is turned off to prevent circulating cool air. Depending on the size and intensity of the fire it may be necessary to adjust the fan speed accordingly to ensure uninterrupted fan operation. For example a small fire may require a slower fan speed to keep the heat output by the fan consistent. If the blower is operated in manual mode, it may be necessary to adjust the blower speed as the fire begins to burn down and the stove is no longer hot enough to effectively heat the air moved by the blower. If the air coming from the blower feels cool, one should either decrease the blower speed or stoke the fire to build up more heat.

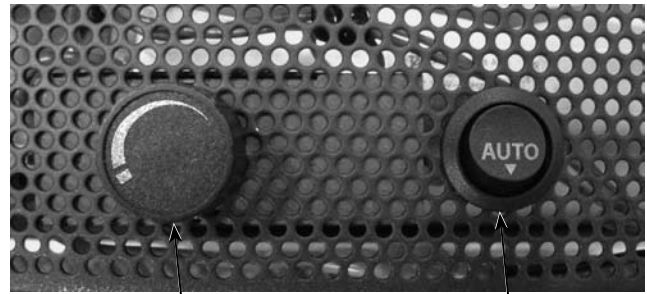

Blower Speed Control Knob (rheostat)

Manual / Auto Rocker Switch

Figure 11 - Blower Controls

⚠ WARNINGS

The blower must be plugged directly into a properly grounded three-prong receptacle, 120 VAC, 60 Hz, single phase. Do not cut or remove the grounding prong from this plug. Do not route power cord under or in front of appliance.

Installation must be in accordance with National Electrical Code, ANSI/NFPA 70 - latest edition. In Canada, the current CSA C22-1 Canadian Electrical Code - latest edition.

DANGER: Disconnect power before servicing blower.

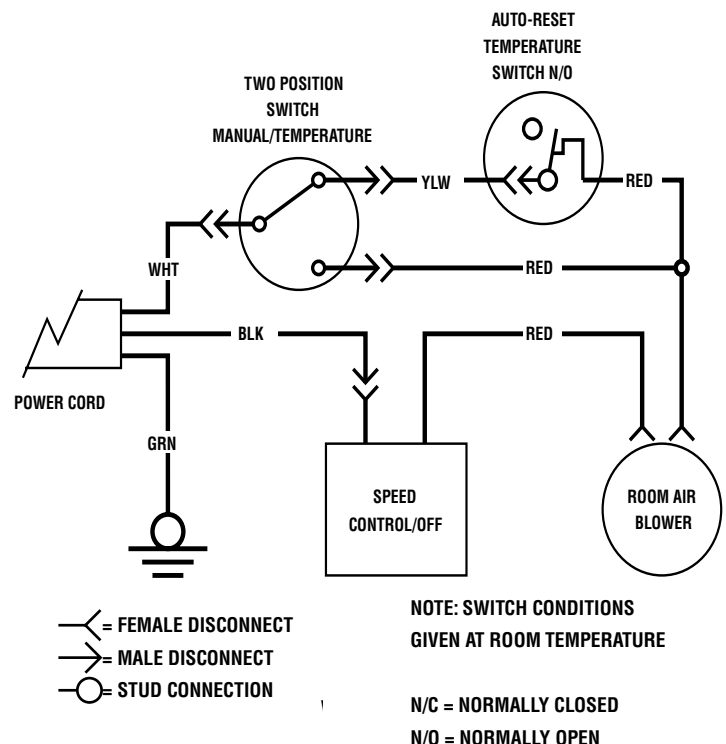

Figure 12 - Blower Wiring Schematic

NOTE: DIAGRAMS & ILLUSTRATIONS ARE NOT TO SCALE.

OPERATING TECHNIQUES AND HINTS

Recent developments in wood-burning technology have made wood-burning a cleaner and more convenient way to heat your home. Overall efficiency in a wood-burning appliance is a combination of combustion efficiency and heat transfer efficiency. Whether heating your entire home, or just a room or two, your understanding of how to best operate your stove or insert will enhance its overall efficiency and performance. What this can mean to you is longer, cleaner burns, less wood use and more heat.

GETTING THE MOST OUT OF YOUR STOVE

The following sections will outline techniques you can use to “get the most out of your stove.” Please read them carefully.

MAXIMIZING YOUR STOVE'S OVERALL EFFICIENCY

It is important to know that for high, combustion efficient, clean burns, you will need to have sufficient temperatures inside the firebox for thorough combustion. The best method for determining if you have sufficient temperatures is to watch the brick lining in your firebox. When you first light your stove, the bricks will turn a dark brown or black. After 20 to 30 minutes of a hot fire, most of the bricks should return to near their original light brown or yellow color. This means the bricks have reached a high enough temperature for your stove to achieve high combustion efficiency.

Second and just as important, is achieving a high level of heat transfer efficiency. Slowing the rate of flow through the stove or insert enhances heat transfer, thus allowing more time for heat to be transferred into your home. To do this, be sure to thoroughly preheat your stove and then reduce the amount of primary air by closing the draft control (lower left) to about 1/2 to 3/4 open. This will decrease the excess oxygen in your flue, which carries heat up your chimney, but should still be enough air to allow the stove to produce its maximum heat output. (More air may produce a lightly greater amount of heat, but will greatly increase wood consumption). When the area being heated reaches a comfortable temperature, slow the burn rate by closing the control to further improve heat transfer.

To get the most out of your stove, you will need to combine good combustion efficiency with good heat transfer practices. The following are some tips on how to operate your stove to achieve the highest overall efficiency.

1. Thoroughly preheat your stove before slowing the burn rate by closing the draft control.
2. Measure the stove temperature at the hottest point on the stove top or face. Use this information to repeat burn rates.
3. Once preheated, add wood (if needed) and partially close the draft control (lower left).
4. Operate your stove as much as possible in the low to medium burn ranges.
5. Do not lower the draft setting so low as to completely extinguish the flames in the firebox. Check for at least some small flames twenty minutes after setting the draft control.
6. Do not continually operate your stove in the high (wide open) setting. This wastes wood by carrying a great deal of heat up the chimney and can damage your stove and chimney.
7. Go outside and check your chimney. More than a very small amount of smoke indicates wasted heat, creosote build up and pollution.

ACHIEVING CLEAN, LONG BURNS

To achieve long burn times, after having thoroughly preheated the stove, let the stovetop cool down to 275 to 400 degrees (on Elites, locate thermometer on the face of the insert just above the door). Now load the firebox and set the draft control. At this point, you may need to burn the stove with the draft open for a few minutes to ignite the wood. All Country™ Collection stoves are EPA tested for emissions at low burn with the air control completely closed. Whether or not you should burn your stove with the air control completely closed will depend on the following factors.

- * How you load your wood.
- * Your chimney type, height and draft.
- * Your wood type and its moisture content.
- * The temperature of the stove.
- * Which model Country Collection stove or insert you have.

Experiment with different loading configurations to achieve longer burns. Try loading the wood from side to side and nesting it in the ashes to prevent airflow under and around the wood. Fresh wood should be loaded to the back of the firebox or to the sides. Hot coals or half burned wood should be brought towards the front of the firebox. The way you load your wood can seriously affect burn times. If the new load does not ignite within a few minutes, try crisscrossing the load to allow more airflow around the fire, or try a slightly hotter stove temperature.

Determining the lowest setting for efficient low burns. This will require some experimentation on your part. Try closing the air control all the way with the stove temperature at 325 degrees to 350 degrees. If the flames are completely extinguished, open the air control halfway and then slowly close it until there is only a small amount of flame. It is important to check the stove about 20 minutes after setting the draft control as it takes this long for the stove temperature to stabilize. There should still be some small flames on or above the wood load.

Use 325 degrees as a starting point. You can try starting temperatures 25 degrees higher or lower to achieve desired burn times, start 25 degrees lower if the stove burns the wood too quickly or 25 degrees higher if there are no flames in the firebox for more than a few minutes after loading the wood. You may or may not need to burn the stove with the air control open for a few minutes prior to setting the draft for a low burn, this will depend on the factors mentioned above. **Be sure not to smolder a fire overnight. Check your chimney for large amounts of smoke as this indicates very poor combustion.**

It is important to realize that stove technology has changed. Stoves have changed a great deal in the last few years. This has led to substantial changes in the methods of operation in new stoves as compared to older stoves. In old stoves without full brick linings and ceramic insulation, the rule was “get the stove as hot as possible before setting the draft on low for overnight burns.” On newer, high technology Country™ Collection stoves, this is not necessary. Although it is still important to have the stove hot enough to burn efficiently, it will require less preheating. Once you have determined your optimum operating temperatures for various burn rates, we believe you will find your stove an extremely convenient way to achieve your heating needs.

Do not reload the stove for long burns when the stainless secondary tubes or baffles are glowing red, or when the stove is uncomfortably hot to load. This indicates the stove is too hot to load for a long burn. Also, do not load wood for a long burn on a deep bed of hot coals. Try stirring the coals a few minutes before loading the stove for a low burn to allow some of the unburned coals time to burn.

MAINTENANCE

DOOR HINGES: If door hinges need lubricating, use an anti-seize compound (never use oil) available from your Lennox Hearth Products dealer.

DOOR LATCH: If your door latch fails to latch tightly and the gasket is in good condition, place a length of pipe (cheater bar) over the inside portion of the door handle and bend slightly toward the door until the proper adjustment is obtained. If the door handle does not close easily, apply high temperature anti-seize to the striker.

DOOR GASKET: Periodically check gasket to make sure it is not over-compressed. If compressed, replace with a special woven door rope. (Don't try substituting rope, only use special Lennox Hearth Products door rope).

GOLD OR NICKEL PLATED DOOR: Clean only with household type glass cleaner and a very soft cotton cloth. Other products may damage brass, paint and gaskets.

BAFFLE BLANKETS: Your baffle blankets should be inspected during every chimney cleaning. If the blanket is compressed or heavily stained, it should be replaced. Heavy creosote stains or matting is an indication of improper use and your burning habits should be reviewed.

GLASS CLEANING: Only clean glass with products specifically made to use on wood stoves. Other products could damage gaskets and paint. Never scrape glass with a razor blade. This can pit the glass and make it impossible to clean in the future.

WINDOW GASKET: The window gasket can be checked by running the flame of a match near the gasket and around the door. If the flame is drawn in around the window, the gasket should be replaced.

DOOR HANDLE: Door handle may become tight as you use the stove. Free the handle up by using dry graphite supplied with the stove. The directions are included with the graphite.



WARNINGS

Inspect and clean chimney and connector frequently. Under certain conditions of use, creosote buildup may occur rapidly.

CLEAN GLASS

SEE MAINTENANCE ON FOR GLASS CLEANING TIPS

The operator plays an important part in keeping the glass clean and free of build-ups. The first and most important part the operator plays is making sure to burn only well-seasoned firewood. **Wet wood = Dirty glass.** Keeping your glass door clean is partly accomplished by the air wash system of the stove, which sends clean, fresh air for combustion, over the window before it enters the fire. The high temperatures inside the firebox also keep the glass clean. **No stove door stays perfectly clean.** The following are methods for keeping build-up on your glass to a minimum. When properly installed and operated by a knowledgeable operator, your glass door should require very little maintenance. Do not expect to get extremely long burn times and keep the window perfectly clean. Cool temperatures cause condensation of unburned volatiles on the glass. If your glass gets very dirty during overnight burning, try preheating the stove a little longer before damping it down for an overnight burn. Also, don't damper your stove down as low because **you'll get more heat for your money by burning a little hotter for a slightly shorter time.**

The air wash system will perform at its best at medium burn rates. Some stove models will self clean by burning very hot fires but be sure not to over-fire the stove. **If it glows red it is over-fired.** Over-firing a stove also causes the window to soot up. Extremely hot fires with fresh wood may cause the flow rate to exceed one foot per second, which is as fast as a flame can burn. This is why a candle goes out when you blow on it. Blow on it gently and it burns brightly. Blow on it hard and it goes out. This will cause excessive exhaust emissions and your window to soot up, as the stove is unable to burn the gases emitted from the wood. Try slowing the stove down a little by closing the damper somewhat as it warms up.

Keeping freshly loaded wood away from the window will also help. Load fresh logs in the rear of the firebox. Build up tends to occur first on the right side of the window. This is caused by the swirling motion of the exhaust gases similar to water running down a drain. Keep fresh logs further back on the right side of the firebox to help prevent this problem.

Understanding how your Country™ Collection stove works should help you keep your glass door very clean, but as stated: **no glass door stays perfectly clean.** We hope this information is helpful in keeping your glass door clean so that you may enjoy many hours viewing your high efficiency stove. For more information, contact your Lennox Hearth Products dealer.



CAUTION

Cleaning Glass: Ensure appliance is cold prior to cleaning glass. A commercial glass cleaner designed for stoves is recommended. Do not use abrasive cleaners. Do not clean with any materials, which may scratch or otherwise damage the glass. Scratches on the glass can develop into cracks or break. Inspect the glass regularly. If you detect a crack, extinguish the fire and contact your dealer for a replacement.

TROUBLESHOOTING

Problem	Solution
POOR DRAFT:	Extend chimney in length or have the chimney realigned to the proper size flue. Oversized chimneys normally have poor drafts. Remember, the stoves' draft depend solely on the natural draft of the chimney (See Drafting section on Page 4). If your stove is not drafting properly, your chimney is the problem. All stoves are thoroughly tested to ensure proper draft with the correct size chimney flue.
EXCESSIVE DRAFT:	With better chimneys being more common, excessive draft can be an issue. Alleviate excessive draft by slowing the burn rate of the stove once it has reached proper operating temperature (See Maximizing Your Stoves Overall Efficiency on Page 14).
DIRTY GLASS:	<ol style="list-style-type: none">1) Burn smaller, hotter fires and check to make sure you are not setting the draft down too far with the draft control.2) Make sure your wood is well-seasoned and dry (not open to rain - see Creosote and Fuel sections on Page 5).3) See Poor Draft section (above) and Clean Glass (above).
SMOKES WHEN DOOR IS OPEN:	<ol style="list-style-type: none">1) If smoke is entering the room, check to make sure your baffle boards are properly installed and that the baffle blankets are pushed back flush with the front of the baffle boards.2) Check the chimney for blockage due to creosote (See Creosote section on Page 5).3) Check draft (See POOR DRAFT section above).
WOOD BURNS TOO FAST:	<ol style="list-style-type: none">1) The draft control must be closed further.2) Add fuel at lower firebox temperatures.3) Load wood side to side and reduce the flow of air under wood.4) The door seal may need replacing, check for leakage.5) See "Excessive Draft."
POOR HEAT OUTPUT:	<ol style="list-style-type: none">1) Check your wood. Wet, moist, unseasoned wood will not produce heat.2) Your stove needs to be seasoned (moisture removed from the steel and brick). Continue to burn a fire. It normally takes from one to three weeks of burning to season your stove (See Burn-In Procedures on Page 5).3) See Excessive Draft section above.
PAINT GIVES OFF ODOR (smoke):	Paint is tempering-in. Burn only moderately hot for the first few days until paint is fully cured. Then burn a very hot fire to cure any paint that may not easily cure. Open windows or door to ventilate (See Burn-In Procedures on Page 5).

DO'S AND DON'T

- DO NOT:** Install or operate this stove before reading this manual.
- DO NOT:** Close the draft beyond the point at which the flames are completely extinguished.
- DO NOT:** Open the stove door without **fully opening** the draft first.
- DO NOT:** Burn driftwood or wood that has been in salt water. This includes some mill ends and scrap lumber that has been floated in salt water on the way to the mill. (This will void your warranty).
- DO NOT:** Handle the Nickel or Gold faceplate unnecessarily. Use the door handle only.
- DO NOT:** Force oversized logs into the firebox as this may dislodge the baffle assembly.
- DO NOT:** Close the door tightly during Burn-In period.
-
- DO:** Be sure to clean any fingerprints from the Gold or Nickel faceplate before burning the stove. Clean the Gold or Nickel door only with a household type glass cleaner and a very soft cloth.
- DO:** Consult local building department if other than recommended clearances are desired.
- DO:** Read instructions for the baffle boards and baffle blankets occasionally to ensure you have not bumped or moved them out of place when loading wood.
- DO:** Check the chimney and baffle monthly to make sure they are clean.
- DO:** Burn seasoned, dry wood only! (RAIN = WET WOOD)
- DO:** Open the door frequently during Burn-In period to keep gasket from adhering to the curing paint.
- DO:** Enjoy the warm feeling of your new Country™ Collection stove.

REPLACEMENT PARTS - MODEL C310

Contact an Authorized Lennox Hearth Products dealer to obtain any of these parts. Never use substitute materials. Use of non-approved parts can result in poor performance and safety hazards.

FRONT DOOR PARTS LIST

Item #	Cat. No	Description
1	H5639	Door Rope Kit, 7/8" Dia. (6' 2")
2	H5629	Upper Hinge Pin
3	H5626	Upper Hinge Pin E-Clip
4	H5630	Lower Hinge Pin
5	H5646	Lower Hinge Pin Copper Washer
6	H5640	Glass Gasket Kit (8' 4")
7	H5577	Set of 6 screws and 6 washers for door assembly
8	H5654	Spring Handle / Nickel
	H5653	Spring Handle / Gold
9	71099	Traditional Door Glass / Plain
	71100	Traditional Door Glass / Sailboat
	71095	Traditional Door Glass / Cattail
	71097	Traditional Door Glass / Evergreen
	71098	Traditional Door Glass / Floral
10	71082	Traditional Door Faceplate / Black
	71083	Traditional Door Faceplate / Gold
	71084	Traditional Door Faceplate / Nickel
	71149	Traditional Door Faceplate / Brushed Gold
	71146	Traditional Door Faceplate / Brushed Nickel
11	H5562	Traditional Door Back w/ Handle (door gasket included)
USB BLOWER PARTS		
15	H8067	UHPI Wiring Harness
16	H5655	UHPI & UHPII Blower Speed Control
17	H8068	Snap Switch Bracket w/ hardware
18	H8082	Replacement Power Cord
19	H8069	UHPI Blower Cage-Snap Switch/ Black
	H8070	UHPI Blower Cage-Snap Switch/ Gold
	H8071	UHPI Blower Cage-Snap Switch/ Nickel
	H8077	UHPI Blower Cage-Snap Switch/ Brushed Gold
	H8078	UHPI Blower Cage-Snap Switch/Brushed Nickel
29	H8064	Snap Switch w/ Gasket and Hardware
32	H8066	Control Switch (Manual, Off, Automatic)

C310 INSERT PARTS

33	71139	Large Flange Screw/ Black - Seven Needed
	H5294	Large Flange Screw/ Gold - Seven Needed
	H5295	Large Flange Screw/ Nickel - Seven Needed
34	H8079	Nameplate Kit w/ Hardware - Silver
	H8080	Nameplate Kit w/ Hardware - Gold
35	H5650	Draft Rod Knob
36	H5645	Side Leveling Bolts - Two Included
37	H5644	Blower Mounting Bolts - Two Needed
38	H5612	Firebrick 4-1/2" x 9" (20 per stove)
39	H5589	Firebrick 4-1/4" x 6-1/2" (4 per stove)
40	H3098	Firebrick 3-7/8" x 8-3/4" (4 per stove)
41	H3100	Firebrick 3-7/8" x 9" (2 per stove)
42	H5614	Firebrick 3-1/2" x 9" (2 per stove)
43	H3099	Firebrick 1-1/2" x 4-1/2" (2 per stove)
44	H5581	Firebrick 3-1/2" x 4-1/2" (1 per stove)
45	H5594	Firebrick 4-1/2" x 4-1/2" (1 per stove)
46	H5566	Complete Baffle/Secondary Burn Tube Assembly (includes tubes and all mounting hardware)
47	H8023	Baffle Blanket 17" x 12-7/16" x 1" - Two Included
48	H8022	Baffle Board Kit w/ Baffle Blankets
MISCELLANEOUS PARTS		
----	71052	Dry Graphite (Apply to door handle and door hinges)
----	H5633	Anti Seize 2 gram pouch

REPLACEMENT PARTS - MODEL C310

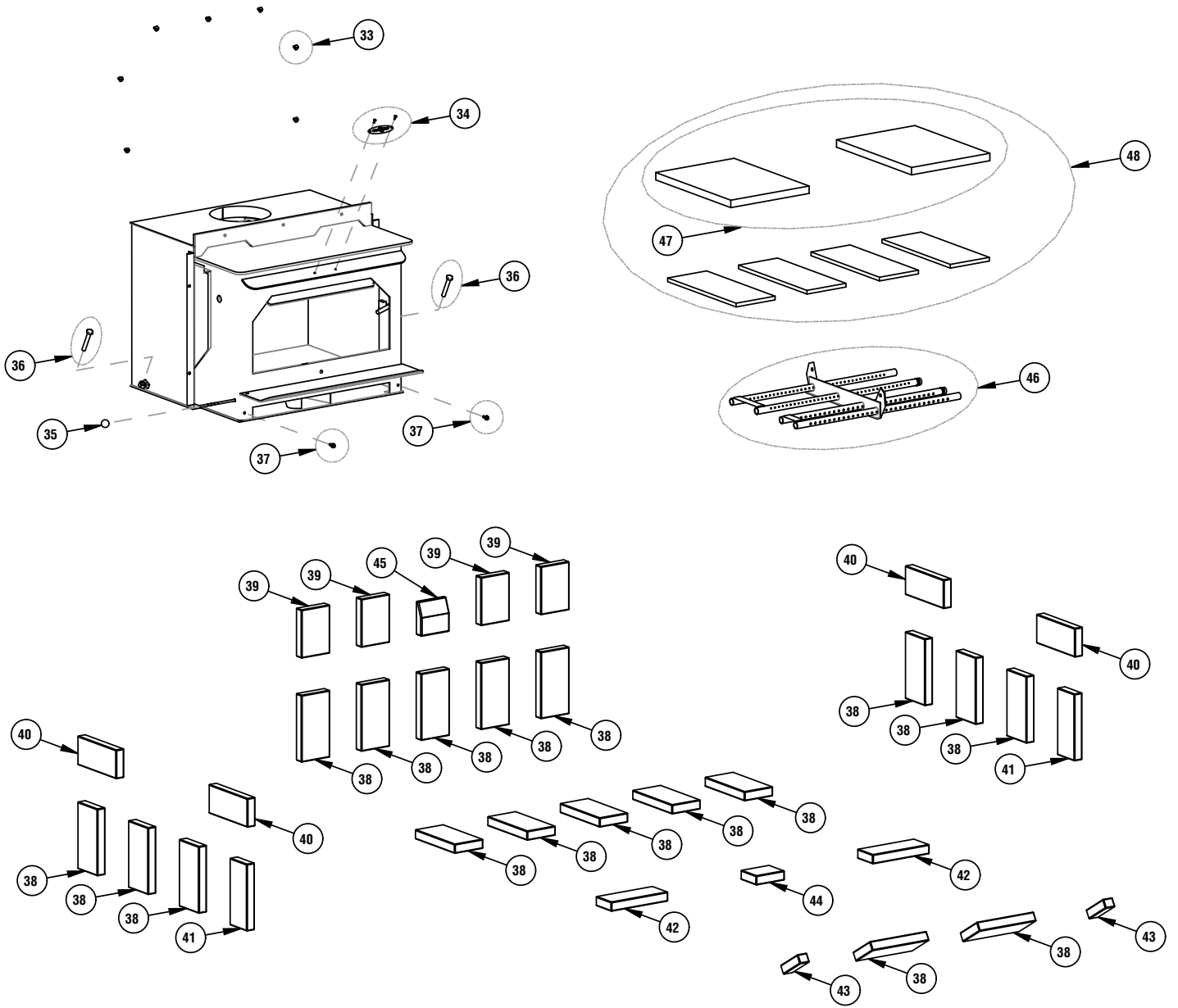

NOTE: DIAGRAMS & ILLUSTRATIONS ARE NOT TO SCALE.

REPLACEMENT PARTS - MODEL C310

Door Parts

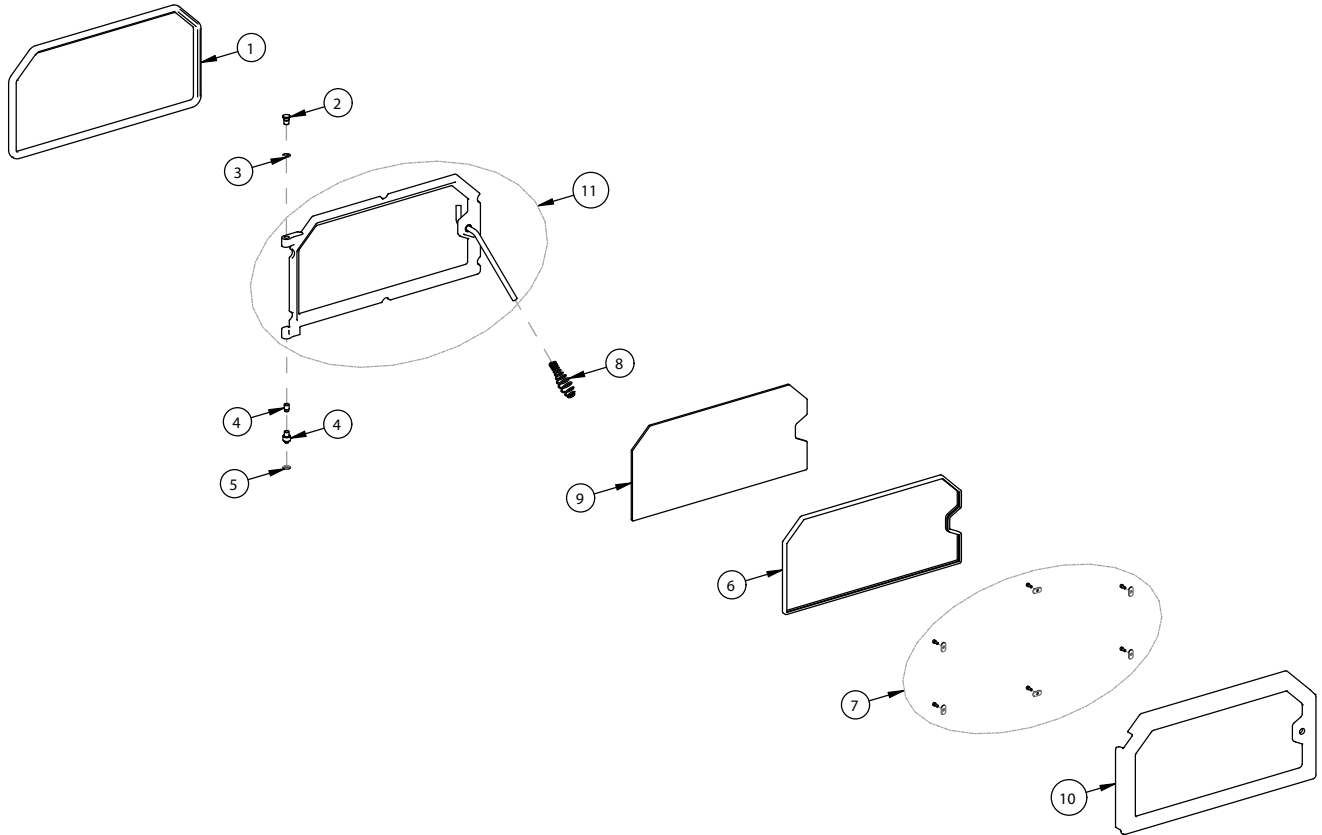

Blower Parts

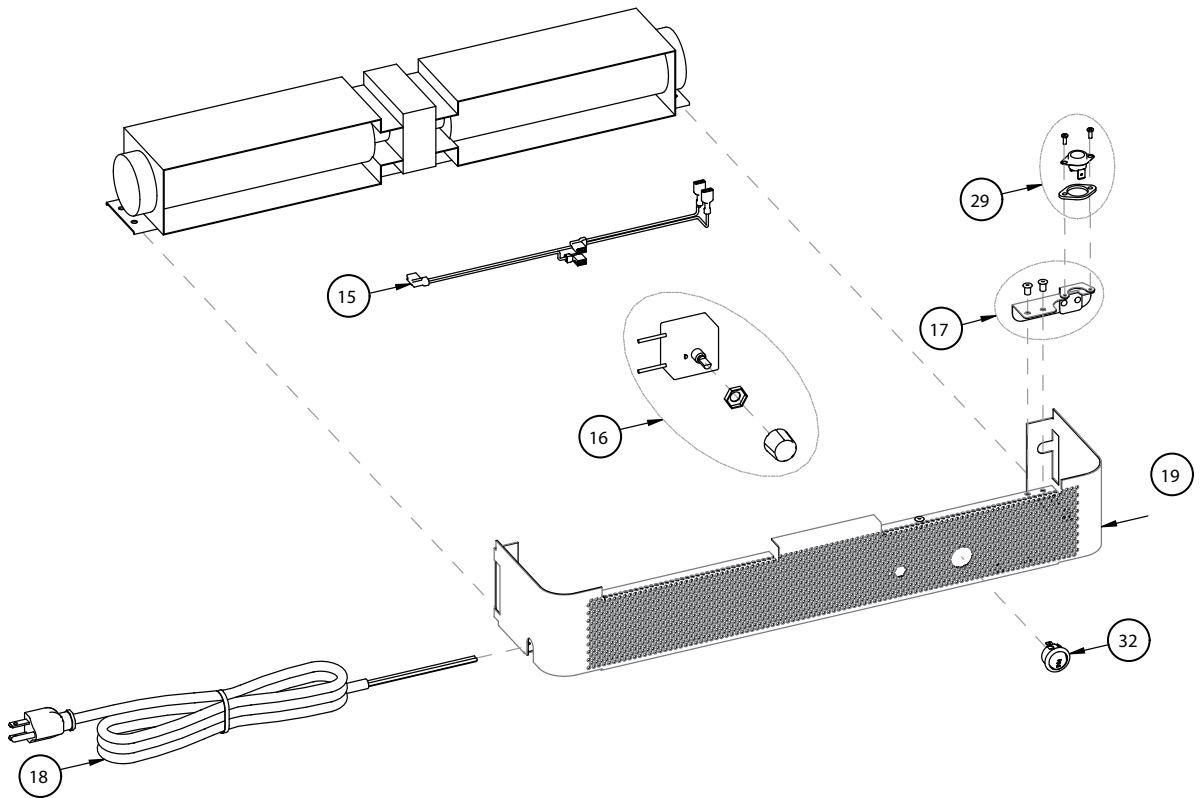

NOTE: DIAGRAMS & ILLUSTRATIONS ARE NOT TO SCALE.

ACCESSORIES - MODEL C310

SURROUND PANELS / TOP AND SIDES (REQUIRED)		
Cat. No.	Model	Description
		29" x 40":
71038	WFPT0740-L	Top Surround 7-1/2" x 40"
71031	WFPS0621	Side Surrounds 6" x 21-5/8"
		29" x 48":
71039	WFPT0748-L	Top Surround 7-1/2" x 48"
71032	WFPS1021	Side Surrounds 10" x 21-5/8"
		33" x 40":
71040	WFPT1140-L	Top Surround 11-1/2" x 40"
71031	WFPS0621	Side Surrounds 6" x 21-5/8"
		33" x 48":
71041	WFPT1148-L	Top Surround 11-1/2" x 48"
71032	WFPS1021	Side Surrounds 10" x 21-5/8"
FACEPLATE KITS (INCLUDES FACEPLATE, HANDLE AND NAMEPLATE)		
71152	TRADFP-BN310	Traditional/Brushed Nickel
TRADITIONAL FACEPLATE KITS (faceplate only)		
71082	TRAD-FP-B-LG	Traditional, Black
71083	TRAD-FP-G-LG	Traditional, Gold
71084	TRAD-FP-N-LG	Traditional, Nickel
71149	TRAD-FP-BG-LG	Traditional Brushed Gold
71146	TRAD-FP-BN-LG	Traditional, Brushed Nickel
SURROUND TRIM - THESE ARE NOT REQUIRED BUT AN OPTION		
71023	WFT2940-B	Black 29" x 40"
71024	WFT2948-B	Black 29" x 48"
71027	WFT3340-B	Black 33" x 40"
71028	WFT3348-B	Black 33" x 48"
71009	WFT2940-G	Gold 29" x 40"
71010	WFT2948-G	Gold 29" x 48"
71013	WFT3340-G	Gold 33" x 40"
71014	WFT3348-G	Gold 33" x 48"
71076	WFT2940-N	Nickel 29" x 40"
71077	WFT2948-N	Nickel 29" x 48"
71080	WFT3340-N	Nickel 33" x 40"
71081	WFT3348-N	Nickel 33" x 48"

BLOWERS		
H7912	WLINS-BLWR-B-SS	Blower Insert Black
H7913	WLINS-BLWR-G-SS	Blower Insert Gold
H7914	WLINS-BLWR-N-SS	Blower Insert Nickel
H7915	WLINS-BLWR-BN-SS	Blower Insert Br-nkl
H7916	WLINS-BLWR-BG-SS	Blower Insert Br-gold
MISC. PARTS		
71053	Paint Gold (1/2 Pint)	Paint Gold (1/2 pint)
71054	Paint Nickel (1/2 Pint)	Paint Nickel (1/2 pint)
70K99	TSPK-B	Touch-Up Paint , Metallic Black, 12 oz. Aerosol
71134	REDUCER 6-8"	Pipe Reducer from 8" to 6" Stainless
H5296	FRNT-SPPT	Front Support 40"- 48" Width / 8"-0" Height <i>(ref. form #775305M)</i>
H6834	OFFADJFLUEBX8SM	Adjustable Offset Flue Box. 8" Flue to 6" Exhaust (0-6")
H6835	OFFADJFLUEBX8LG	Adjustable Offset Flue Box. 8" Flue to 6" Exhaust (6-12")
71134	REDUCER 8-6"	Pipe Reducer from 8" to 6" Stainless
71162	WINS-8FC	8" Positive Flue Connector Ring Kit <i>(ref. form #775232M)</i>
71163	WINS-8/6REDCR	8" to 6" Reducer w/ Positive Flue Connector <i>(ref. form #775233M)</i>

SAFETY / LISTING LABEL

CONTACT YOUR LOCAL BUILDING OR FIRE OFFICIALS ABOUT RESTRICTIONS AND INSTALLATION INSPECTION IN YOUR AREA
COMMUNIQUEZ AVEC LES AUTORITÉS LOCALES EN BÂTIMENT OU LE SERVICE DE PRÉVENTION DES INCENDIES POUR CONNAÎTRE LES NORMES D'INSTALLATION ET D'INSPECTION DE VOTRE RÉGION

Listed Masonry Fireplace Accessory/Insert / Poêle encastrable certifié pour installation dans un foyer de maçonnerie



Manufactured By / Fabriqué Par:
LENNOX HEARTH PRODUCTS
PO BOX 987
Auburn, WA 98071 USA



"PREVENT HOUSE FIRES"

Install and use only in accordance with manufacturer's installation instructions and your local building codes. Do not connect this unit to a chimney flue serving another appliance.

Optional Blower, Part No.s: H7912 (black), H7913 (gold), H7914 (nickel), H7916 (brushed gold), H7915 (brushed nickel)

Blower Electrical Rating: 120V, 60 Hz, 1 Amp
Trans Flow, QLN 652424-3045L

Do not route power cord under or in front of appliance.

Report No./Numéro de Rapport: 050-S-10b-4
(Test Date June 11, 1991 / Testé le 11 Juin 1991)

Serial No. / Numéro de série **C310-**

Model / Modèle: C-310

Tested to/Testé selon: UL 1482, ULC S628-93

Type Of Fuel: Solid Wood Only

Minimum Clearance to Combustible Materials - Inches (millimeters)

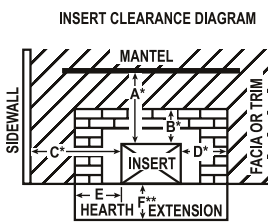

- (A) Clearance from Insert top to Mantel = USA-30", CAN-31" (787mm). Maximum mantel depth = 9"
- (B) Clearance from insert top to combustibles = USA -20" CAN-23" (584mm)
- (C) Minimum clearance to combustible sidewall = 20" (508mm)
- (D) Minimum clearance to combustible side trim = 15" (381mm)
- (E) Minimum distance of floor protection to the side = 8" (200mm). This is measured from the sides of the door opening in the USA and from the sides of the insert in Canada.
- (F) Minimum distance from front of insert to combustible = 24" (610mm)

The hearth and/or floor protection must be a thermally rated non-combustible hearth/floor protector meeting or exceeding a thermal rating of k=.84 or equivalent with a listed thickness of 3/4" (19mm) minimum in the USA and Canada. Install only in a masonry fireplace, built to UBC Chapter 37. Do not remove brick or mortar from masonry fireplace to accommodate insert. Use flue outlet with or without a direct connector. Approved with minimum 6" (152mm) diameter stainless steel listed reline system. Remove and clean behind unit frequently, as creosote build up may occur rapidly. See owner's manual for reductions on mantel, trim and floor protection.

* Reduced clearances may be available for A, B, C, and D dimensions by using optional mantel and/or side shields. Consult with your Lennox Hearth Products dealer for the dimensions of the shields.

** Hearth extension reductions: 2" (51mm) reduction for 2" (51mm) raised hearth. 16" (406mm) minimum hearth extension on all inserts as measured from the door opening of the unit.



CAUTION: HOT WHILE IN OPERATION. DO NOT TOUCH. AND COMBUSTIBLE MATERIAL A CONSIDERABLE DISTANCE AWAY. CONTACT MAY CAUSE SKIN BURNS. SEE NAMEPLATE AND INSTRUCTIONS. DO NOT OVERFIRE. IF HEATER OR CHIMNEY CONNECTOR GLOWS, YOU ARE OVERFIRING. INSPECT AND CLEAN CHIMNEY AND CONNECTOR FREQUENTLY. UNDER CERTAIN CONDITIONS OF USE, CREOSOTE BUILDUP MAY OCCUR RAPIDLY. DO NOT USE GRATE OR ELEVATE FIRE - BUILD WOOD FIRE DIRECTLY ON HEARTH. FEED DOOR MUST BE CLOSED DURING FIRING EXCEPT WHEN ADDING FUEL. KEEP ASH DOOR CLOSED TO AVOID EXCESS HEAT. DANGER: RISK OF ELECTRICAL SHOCK. DISCONNECT POWER BEFORE SERVICING UNIT.

TYPE OF FUEL: SOLID WOOD ONLY.

Date of Manufacture / Date De Fabrication

2010	2011	2012	JAN.	FEB.	MAR.	APR.	MAY	JUN	JUL	AUG	SEP	OCT	NOV	DEC
			JANV	FEVR	MARS	AVR	MAI	JUIN	JUIL	AOÛT	SEPT	OCT	NOV	DEC

U.S. ENVIRONMENTAL PROTECTION AGENCY

Certified to comply with July 1990 particulate emission standards.

Part No./No. pièce #36211 Rev. B, 1/2010 DO NOT REMOVE THIS LABEL Made in U.S.A.

"PREVENTION DES INCENDIES"

Installer et utiliser l'appareil en conformité avec les directives d'installation du fabricant et des autorités locales en bâtiment ou le service de prévention des incendies. Ne pas brancher cette unité à un conduit de fumée raccordé à un autre appareil.

Type de combustible: Bois seulement

Ventilateur Optionnel, No. De Pièces : H7912 (noir), H7913 (plaqué or), H7914 (plaqué nickel), H7916 (plaqué or, fini brossé), H7915 (plaqué nickel, fini brossé)
Spécification Électrique Du Ventilateur : 120V, 60 Hz, 1 Amp
Trans Flow, QLN 652424-3045L
Ne pas faire passer le fil électrique sous ou en avant de l'appareil

Dégagements Minimums Aux Matériaux Combustibles - En Pouces (millimètres)

DÉGAGEMENT REQUIS POUR L'ENCASTRABLE

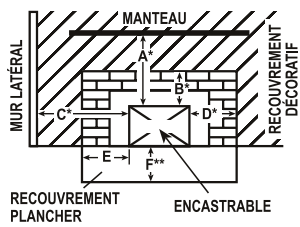

- (A) Espace entre l'encastable et le manteau de cheminée = USA-30", CAN-31" (787mm). Profondeur maximum de la tablette du manteau de cheminée 9"
- (B) Espace entre l'encastable et les matériaux combustibles du haut = USA -20" CAN-23" (584mm)
- (C) Espace minimum entre l'encastable et le mur de côté combustible = 20" (508mm)
- (D) Espace minimum entre l'encastable et les matériaux combustibles du côté = 15" (381mm)
- (E) Minimum requis de matériel non combustible au plancher, de chaque côté de l'ouverture de l'appareil = 8" (200mm)
- (F) Minimum requis de matériel non combustible à l'avant de l'appareil = 24" (610mm)

Le panneau protecteur de plancher doit être un matériel non combustible, dont l'épaisseur minimale 3/4" - 19mm et dont le facteur k est de 0.84 ou l'équivalent. Installer seulement dans un foyer de maçonnerie construit selon UBC Chapitre 37 ou dans un foyer approuvé par le fabricant (référez-vous au manuel). Ne pas enlever de ciment ou de briques pour installer l'encastable. L'installation de la cheminée peut s'effectuer avec ou sans connecteur à la sortie de l'appareil. Approuvé pour raccordement avec un conduit de tubage certifié en acier inoxydable de 6" (152mm) de diamètre. Tirer l'appareil et nettoyer l'arrière fréquemment car le créosote peut s'y accumuler rapidement.

*Les dégagements minimums peuvent être réduits pour A, B, C, D en utilisant un manteau optionnel et / ou des protecteurs latéraux. Contacter votre détaillant Lennox pour la dimension des protecteurs requise.

**Réduction du recouvrement de plancher : 2" (51mm) de moins si l'encastable est élevé de 2" (51mm). Respecter 16" (406mm) de recouvrement de plancher minimum à l'avant de l'encastable.



ATTENTION: L'APPAREIL EST CHAUD LORS DE L'OPÉRATION. NE PAS Y TOUCHER. RISQUE DE BRÛLURES CUTANÉES. TENIR LES ENFANTS, LES MATÉRIEAUX COMBUSTIBLES, LES VÊTEMENTS ET LES MEUBLES ÉLOIGNÉS DE L'APPAREIL. VOIR LA PLAQUE SIGNALÉTIQUE ET LES DIRECTIVES. NE PAS SURCHAUFFER L'APPAREIL. SI L'APPAREIL OU LE TUYAU DE CHEMINÉE ROUGIT, VOUS SURCHAUFFEZ. INSPECTER ET NETTOYER LA CHEMINÉE ET LE TUYAU CONNECTEUR FRÉQUEMMENT. SOUS CERTAINES CONDITIONS, IL SE PEUT QUE LE CRÉOSOTE S'ACCUMULE RAPIDEMENT. NE SURÉLEVER PAS LE FEU À L'AIDE D'UN CHENET. DÉPOSER LES BÛCHES DE BOIS DIRECTEMENT SUR L'ÂTRE. LA PORTE DOIT ÊTRE FERMÉE PENDANT L'USAGE SAUF POUR ALIMENTER LE FEU. GARDER LA PORTE "BY-PASS" (CENDRES) FERMÉE POUR ÉVITER DE SURCHAUFFER.

DANGER: RISQUES DE DÉCHARGE ÉLECTRIQUE. DÉCONNECTER LE FIL ÉLECTRIQUE DE LA PRISE DE CONTACT AVANT LE SERVICE. NE PAS FAIRE PASSER LE FIL ÉLECTRIQUE SOUS OU EN AVANT DE L'APPAREIL.

DANGER: RISQUES DE DÉCHARGE ÉLECTRIQUE. DÉCONNECTER LE FIL ÉLECTRIQUE DE LA PRISE DE CONTACT AVANT LE SERVICE. NE PAS FAIRE PASSER LE FIL ÉLECTRIQUE SOUS OU EN AVANT DE L'APPAREIL.

TYPE DE COMBUSTIBLE: BOIS SEULEMENT

NE PAS ENLEVER OU RECOUVRIR CETTE ÉTIQUETTE

Fabriqué aux U.S.A.

IGN 09-2566

NOTES

WARRANTY

Your wood appliance is covered by a limited warranty (provided with the appliance). Please read the warranty to be familiar with its coverage.

Retain this manual. File it with your other documents for future reference.

REPLACEMENT PARTS

See **Page 18** for a complete replacement parts list. Use only parts supplied from the manufacturer.

Normally, all parts should be ordered through your Lennox distributor or dealer. Parts will be shipped at prevailing prices at time of order.

When ordering repair parts, always give the following information:

1. The model number of the appliance.
2. The serial number of the appliance.

3. The part number.
4. The description of the part.
5. The quantity required.
6. The installation date of the appliance.

If you encounter any problems or have any questions concerning the installation or application of this system, please contact your dealer.

LENNOX HEARTH PRODUCTS

1508 Elm Hill Pike, Suite 108
Nashville, TN 37210
visit us at www.Lennox.com
1-800-9-LENNOX

PRODUCT REFERENCE INFORMATION

We recommend that you record the following important information about your appliance. If you did not purchase your appliance directly from a Lennox Hearth Products dealer, then please call 1-800-9-LENNOX for the name and phone number of your nearest Lennox Hearth Products dealer who will answer your questions or address your concerns.

Your Appliance's Model Number _____

Your Appliance's Serial Number _____

The Date On Which Your Appliance Was Installed _____

Your Dealer's Name _____



We recommend that our woodburning hearth products be installed and serviced by professionals who are certified in the U.S. by the National Fireplace Institute® (NFI) as NFI Woodburning Specialists or who are certified in Canada by Wood Energy Technical Training (WETT).



Nous recommandons que nos p eles   bois soient install es et que l'entretien soit effectu  par des professionnels certifi s, aux Etats-Unis par le National Fireplace Institute® (NFI) et au Canada, par le Wood Energy Technical Training (WETT).



Lennox Hearth Products reserves the right to make changes at any time, without notice, in design, materials, specifications, prices and also to discontinue colors, styles and products. Consult your local distributor for fireplace code information.

