



HEARTH PRODUCTS

HOMEOWNER'S CARE AND OPERATION INSTRUCTIONS

MERIT® PLUS SERIES

36" and 42" Indoor/Outdoor Wood-Burning Fireplaces
P/N 875029M Rev. B 10/2011

MODELS

MP-360D

MP-420D



MP-420D



MP-360D

The information contained in this manual applies to all model fireplaces identified on this page. This information will help you obtain safe and dependable service from your Lennox fireplace system. Keep this document in a safe place for future reference.

Before you start your first fire, read this Care and Operations Manual carefully to be sure you understand your fireplace system completely. Failure to follow these suggestions could result in hazardous operation or fireplace malfunction, creating a serious potential for personal injury and/or property damage.

If you have any questions regarding the safe use or operation of your fireplace, contact your local Lennox distributor, or your contractor / builder.

A French manual is available upon request. Order P/N 875029CF.

Ce manuel d'installation est disponible en francais, simplement en faire la demande. Numéro de la pièce 875,029CF.

RETAIN THESE INSTRUCTIONS FOR FUTURE REFERENCE

VEUILLEZ GARDER CE MANUEL POUR RÉFÉRENCE FUTURE.

NATIONAL FIREPLACE INSTITUTE



CERTIFIED

www.nficertified.org

We recommend that our woodburning hearth products be installed and serviced by professionals who are certified in the U.S. by the National Fireplace Institute® (NFI) as NFI Woodburning Specialists or who are certified in Canada by Wood Energy Technical Training (WETT).



WARNING: EXERCISE CAUTION WHEN OPERATING IF INSTALLED OUTDOORS. DO NOT BURN LARGE FIRES. ATMOSPHERIC CHANGES MAY CAUSE UNEXPECTED GUSTS OF WIND. FLAMES AND ASHES MAY BE BLOWN OUT OF THE FIREPLACE. KEEP THE SCREEN CURTAINS CLOSED AT ALL TIMES AFTER FEEDING THE FIRE.

AVERTISSEMENT: EXERCISE GUARANTEE WHEN OPERATING IF THIS APPLIANCE IS INSTALLED OUTDOORS. BROAD C NOT BURN FIRES. ATMOSPHERIC EXCHANGES MAY CAUSES UNEXPECTED GUSTS OF WIND. FLAMES AND ASHES MAY BE BLOWN OUT OF THE FIREPLACE. KEEP THE SCREEN CURTAINS CLOSED AT ALL.

Tested & Listed By



Beaverton Oregon USA

OMNI-Test Laboratories, Inc.

OTL Report No.

(MP-360D) #116-F-35-2

(MP-420D) #116-F-37-2

CONGRATULATIONS!

In selecting this LENNOX Wood Burning Appliance you have chosen the finest and most dependable fireplace to be found anywhere. Its a beautiful, prestigious alternative to a masonry wood burning fireplace. Welcome to a Family of tens of thousands of satisfied LENNOX Fireplace Owners.

Please carefully read and follow all of the instructions found in this manual. Please pay special attention to the safety instructions provided in this manual. The Homeowner's Care and Operation Instructions included here will assure that you have many years of dependable and enjoyable service from your LENNOX product.

TABLE OF CONTENTS

General Safety Precautions	Page 2
General Information	Page 2
Fuels	Page 3
Gas Logs	Page 3
Wood Fuel Pointers	Page 3
Disposal of Ashes	Page 4
Softwood vs Hardwood	Page 4
Starting a Fire	Page 4
Damper Control	Page 5
Glass Door Operating Safety	
Precautions and Instructions	Page 4
Combustion Air Inlet	Page 5
Maintenance Guidelines	Page 6
Refractories	Page 8
Twice a Year Check-Up	Page 7
Creosote Formation and Removal	Page 8
Troubleshooting	Page 9
Warranty	Page 10
Product Reference Information	Page 10
Accessory Components	Page 10
Replacement Parts	Page 11

IMPORTANT! GENERAL SAFETY PRECAUTIONS. READ AND UNDERSTAND THESE SAFETY RULES BEFORE YOUR FIRST FIRE.

WARNING

To avoid the risk of damaging fireplace materials and increasing the risk of fire, do not use the fireplace to cook or warm food.

AVERTISSEMENT

Pour éviter le risque d'endommager les matériaux du foyer et d'augmenter le risque d'incendie, n'employez pas le foyer pour faire cuire ou réchauffer de la nourriture.

1. NEVER LEAVE CHILDREN UNATTENDED WHEN THERE IS A FIRE BURNING IN THE FIREPLACE.

2. When burning wood, use **SOLID NATURAL DRY WELL-SEASONED WOOD ONLY**. Hardwoods are recommended (soft woods tend to burn very quickly).

- DO NOT burn treated wood, charcoal, coal, trash, driftwood, woods dipped in tar, Christmas tree greens, pitch, pine tar, creosote, chemical chimney cleaners, flame colorants, polystyrene packaging, wood products with synthetic binders (i.e. plywood). Plywood, lumber and other misc. materials can produce abnormally high temperatures, sputtering and smoking fires and may contain hazardous chemicals to treat insects and fungus.

- If *Artificial Logs* are burned it is required that the logs are UL safety listed (see labeling or documentation provided with logs). Read and follow the log manufacturer's instructions. Do not treat artificial logs (made from sawdust and wax) the same way you treat real natural wood logs. Use only one at a time.

- **IMPORTANT:** Burning unapproved fuels can produce excessive temperatures, beyond the design capabilities of the fireplace and may produce excess sparks or may contain hazardous chemicals. **Burning unapproved fuels can result in a chimney fire, a house fire, personal injury, death or loss of property.**

3. NEVER use gasoline, gasoline-type lantern fuel, kerosene, charcoal lighter fluid, NAPHTHA, ENGINE OIL or similar liquids to start or "freshen up" a fire in this fireplace. Keep any flammable liquids a safe distance from the fireplace.

4. Keep the chimney damper open while any fire or smoldering embers are present .

5. Use care when selecting window treatments for windows located near the fireplace. Avoid using combustible flowing window treatments such as curtains on nearby windows that are of sufficient length to be blown in front of an open flame when the window is opened.

6. With the fire burning, close the protective mesh screens to keep sparks and embers INSIDE the firebox. Closed screens prevent fire, sparks and embers from popping out of the firebox while a fire is burning. Pull screens back when adding wood to the firebox.

7. Keep any combustible furniture or decorative pillows at least 60" (1524 mm) from the fireplace opening.

8. Never leave your fireplace unattended while it is burning.

9. Be careful adding wood fuel to the fire or handling fireplace tools such as shovels, tongs or pokers.

10. Never modify or alter your fireplace system in any way. To do so may create a potential fire hazard and void the Limited Warranty.

11. The bottom refractory can be cracked by excessive abuse such as tossing heavy logs onto the grate or gouging with fireplace tools. Exercise caution when adding wood to your fireplace.

12. Fireplace Inserts - Contact your dealer or distributor for a list of Lennox fireplace inserts approved for installation into your fireplace. DO NOT install a fireplace insert from any another manufacturer.

13. If you are using your fireplace as a "decorative appliance," such as with a permanently installed gas log set, the fireplace damper must be permanently fixed in the open position. Listed "vent-free" gas log sets may be used with the damper closed.

14. If this unit is installed indoors, always ensure that an adequate supply of replacement combustion air from the outside of the house is accessible to the fire to support normal combustion. Fireplaces consume large volumes of air during the normal combustion process. In the event the home is tightly sealed with modern energy efficient features, the optional combustion air kit may not provide all the air required to support combustion. The manufacturer is not responsible for any smoking or related problems that may result from the lack of adequate combustion air. It is the responsibility of the builder/contractor to ensure that adequate combustion air has been provided for the fireplace.

15. Neither the manufacturer nor the seller warrants "smoke free" operation nor are we responsible for inadequate system draft caused by mechanical systems, general construction conditions, inadequate chimney heights, adverse wind conditions and/or unusual environmental factors or conditions beyond our control.

16. Always ensure that the air inlet to the fireplace is free from debris and any other obstructions that can block the entrance of air.

GENERAL INFORMATION

1. The all-steel, multi-wall firebox is the heat center of the system. It is well insulated for safe clearance to combustibles.

2. The hearth floor and sidewalls of the firebox are lined with a brick pattern reinforced refractory for the look of authenticity and to provide safety.

3. The metal chimney sections extending from the firebox top to beyond your roof are two walled and air-cooled. The inner passage, or flue, provides the exit for smoke and gases.
4. The flue damper is a two position (fully open or fully closed) mechanism operated by a handle found at the center top of the fireplace opening. It must be open when fire is present so smoke and gases can escape. It should be closed only when the fire is completely out – keeping room air from being lost up the flue.
5. Closed screens prevent fire, sparks and embers from popping out of the firebox while a fire is burning. Pull screens back when adding wood to the firebox.
6. Why use a fuel grate? Besides positioning the firebed properly, it protects the refractory floor, back and sides of the fireplace. Further, it ensures a proper flow of combustion air into and around the firebed. The grate must be used at all times when burning. Your warranty may be voided without the use of this grate.
7. This fireplace is not a heater. It is designed to ensure homeowner comfort by providing supplemental heat to its immediate area.

FUELS

Never Use Coal in Your Fireplace

Your fireplace system is not designed to be used with coal derivative products. The combustion process of certain types of coal can deposit corrosive materials in the fireplace and chimney system which can lead to premature product failure. Never use coal as a fuel in this fireplace system.

Gas Logs

If your fireplace system was installed with a gas line, you may wish to install one of two types of gas log sets.

This fireplace has been tested and approved for use with a decorative gas appliance incorporating an automatic shut-off device and complying with the Standard for Decorative Gas Appliances for installation in vented fireplaces, ANSI Z21.60 (latest edition). Decorative gas appliances may be installed in these fireplaces. Installation must be in accordance with the National Fuel Gas Code, ANSI Z223.1 for compliance with the revised U.L. 127 Standard.

⚠ CAUTION
When using a decorative gas appliance, the fireplace damper must be set in the fully open position.

⚠ ATTENTION
Si vous utilisez un appareil décoratif au gaz, le registre de la cheminée du foyer doit être ouvert complètement.

⚠ WARNING
Unvented Gas Log Sets are not approved for use with fireplaces installed outdoors. The materials and components will deteriorate prematurely if installed outside. Refer to the log manufacturer's literature for limitations and exceptions.

⚠ AVERTISSEMENT
Les ensembles de bûches à gaz sans conduit d'évacuation ne sont pas approuvés pour l'usage avec des foyers installés à l'extérieur. Les matériaux et les composants se détérioreront prématurément si installés à l'extérieur. Référez-vous à la littérature du fabricant des bûches pour les limites et les exceptions.

This fireplace has been tested and approved to ANSI/IAS/AGA Z21.11.2 for use with an unvented gas appliance having a maximum rating of 26,000 BTU and complies with the Standard for Factory-Built Fireplaces, U.L. 127, when installed with unvented gas log sets. The limit may be increased to 40,000 BTU providing that minimum combustible mantel heights were increased to at least 18 inches when the fireplace was installed.

Prior to installing any gas log set, (Vented or Unvented) refer to the fireplace installation instructions for verification of mantel heights and placement of combustible materials around the firebox opening.

⚠ IMPORTANT
Never install an unvented gas log set with a BTU greater than 26,000 if combustible mantel projections are lower than 18 inches above the fireplace opening.

⚠ ATTENTION
Ne jamais installer un ensemble de bûches à gaz sans conduit d'évacuation qui génère une puissance supérieure à 26000 si un manteau combustible est installé plus bas que 18 po. Au dessus de l'ouverture du foyer.

Vented gas log sets do not have restrictions placed upon their BTU rating.

Wood Fuel Pointers

Wood is a wonderful renewable fuel source. Normally it burns clean, leaving only a minimum of waste ash, provides comforting heat and can provide a variety of aromas and visual images.

You will want to know which woods are best for use. Sometimes you may want a quick, short fire to offset a morning chill. Soft woods are preferable in this case. Other times you would want more slow burning and a uniform heat output. Hardwoods are preferable for this use.

The amount of heat available from the logs will be about equal on a weight basis. However, logs are generally not weighed so the amount of heat will depend on:

1. The type of wood used.
2. How dry it is.
3. How many logs you put in.
4. The size of the logs.

The last statement means that one big log weighing 10 pounds has as much heating potential as 10 pounds of twigs. However, air cannot get at the solid log to feed the fire so the solid log will burn slowly. While you would get the same amount of heat out of either fire, the smaller the pieces of wood and the more air space around them, the faster the fire will burn.

DISPOSAL OF ASHES

Ashes should be placed in a metal container with a tight fitting lid. The closed container of ashes should be placed on a noncombustible floor or on the ground, well away from all combustible materials, pending final disposal. If the ashes are to be disposed of by burial in soil or other wise locally dispersed, they should be retained in the closed container until all cinders have thoroughly cooled.

SOFTWOOD VS HARDWOOD

Softwoods contain about 15 percent highly flammable resin which generates creosote soot in the chimney flue. Burning softwood exclusively may not be as desirable nor as safe as burning denser hardwoods. Many experienced fire-builders use small amounts of softwood kindling and newspaper in conjunction with starting a fire with split hardwood logs. Here are some guidelines to remember:

1. Softwoods produce fast warming and shorter fires. Hardwoods burn less vigorously, have shorter flames and produce steady, glowing coals.
2. As a general rule, denser woods contain more potential heat per pound. Most softwoods offer moderate heat value per pound.
3. Different woods vary widely in flame heights, flame intensities, smoke characteristics and in sparking. Most hardwoods do not spark.
4. Most freshly cut "green" wood will not burn well and will smoke. Green wood can be from 10 to 40 percent less efficient than air-dried seasoned wood.
5. Moisture and resin found inside unseasoned wood cells will build up pressure under heat and explode as sparks.
6. Most wood needs to be seasoned 9 to 12 months to reduce the moisture content and produce good steady fires. When moisture content is reduced from 60 to 20%, the gain in heat potential is nearly 7%.
7. Proper storage of wood, especially during seasoning, is essential. We recommend that you:
 - a. Never store wood on the ground. This will cause rotting and insect infiltration. Raise wood on flat rock or scrap wood.
 - b. Stack wood loosely to allow air circulation.
 - c. Store wood where it will not be excessively exposed to weather, such as under a tarp or under a roof.

d. Do not stack wood directly against the walls of your home.

8. Be a knowledgeable wood buyer. There is a difference in cord sizes. A standard cord stack of logs is 4 ft. high by 8 ft. long by 4 ft. deep or the equivalent of this cubic footage, (*Figure 1*).

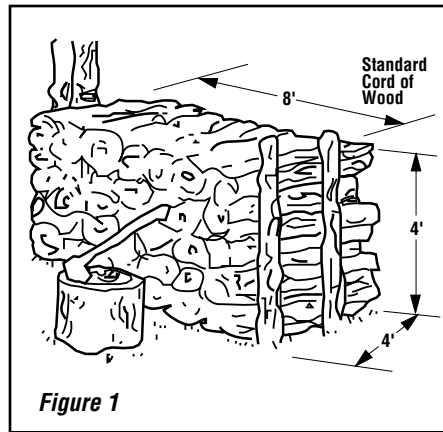

Figure 1

A face cord is the same height and length as a standard cord but the depth is only the length of the logs (12, 18 or 24 inches). A face cord can contain as little as 25% of the wood found in a standard cord.

If you buy by the ton, remember that wood becomes lighter as it dries. When buying green or wet wood, ask for some extra poundage to allow for the extra water you will be getting.

9. When comparing woods of the same moisture content and same species, we find most woods have approximately the same heating potential per pound.

However, most wood is sold by volume, not by weight. To determine the best heating source, look at the density of various wood types. (Density is the weight for a given size.) The higher the density, the more potential heat output. A standard cord has a volume of 128 cubic feet. This Figure also includes the air space between and around the wood. The actual volume in a standard cord is between 60 and 100 cubic feet; depending on how tightly the wood is packed.

Assuming that you are comparing two standard cords of different species but the same volume and moisture content, the denser species will provide more BTU's. The table of wood species/densities reveals more helpful guidelines.

HARDWOODS	DENSITY
Alser, Red	.41
Ash	.49-.60
Aspen	.38-.39
Basswood, American	.37
Beech, American	.64
Birch	.55-.65
Butternut	.38
Cherry, Black	.50
Chestnut, American	.43
Cottonwood	.34-.40
Elm	.60.63
Hackberry	.53
Hickory, Pecan	.60.66
Hickory, True	.69-.75
Honey locust	.66 (est.)
Locust, Black	.69
Magnolia	.48-.50
Maple	.48-.63
Oak, Red	.59-.67
Oak, White	.64-.88
Poplar	.42
Sassafras	.42
Sweet gum	.52
Sycamore, American	.49
Tanoak	.64 (est.)
Tupelo	.50
Walnut, Black	.55
Willow, Black	.39
SOFTWOODS	DENSITY
Bald cypress	.46
Cedar	.31-.47
Douglas Fir	.46-.50
Fir	.32-.43
Hemlock	.40-.45
Larch, Western	.52
Pine	.39-.59
Redwood	.35-.40
Spruce	.35-.41
Tamarack	.53

STARTING A FIRE

Note: For outdoor installations, caution must be observed when operating this fireplace under windy conditions. **Do NOT burn large fires in windy conditions**, as flames may be drawn out of the firebox. If this occurs, close the glass doors immediately. If not equipped with doors, extinguish the fire. The screens must be closed at all times while the fireplace is in operation, except when feeding the fire.

1. To properly start a fire in a the fireplace, first check the operation of the flue damper (see "DAMPER CONTROL" and *Figure 2, next page*).
2. For indoor installations, to prevent smoke at startup, close all windows near the fireplace when first lighting a fire. The closed windows may be reopened once a chimney draft is drawn in the fireplace.
3. Center the grate in the firebox on or over the bottom hearth so the fire can breathe properly. Crumble and twist plenty of newspapers UNDER the grate, and criss-cross some small, dry kindling sticks on top of the paper or on the bottom of the grate.

(Continued on next page)

4. Build a pyramid of three split logs (split wood will light more quickly). Arrange the logs to provide plenty of air space between them.

5. Light the paper at both sides of the firebox.

Note: When lighting a fire, some smoke may escape into the room, especially if the chimney is cold. To correct this, hold a lighted newspaper up inside the firebox, near the chimney opening. This will turn around any downdraft and clear the flue of cold air. As the log fire burns, the updraft will improve as the chimney heats up.

6. Close the screens to prevent the escape of sparks and embers.

7. Close the damper only when the fire is completely OUT and ashes are COLD. Keep damper closed when fireplace is not in use, to prevent unnecessary loss of conditioned room air.

DAMPER CONTROL

This fireplace is fitted with a manually controlled chimney damper.

The damper is controlled through the use of a damper rod inside the top center of the firebox opening, behind the lintel (**Figure 2**).

- To **CLOSE** the damper, pull the damper rod **FORWARD** (toward the front of the fireplace), then slide **LEFT** until locked in position.
- To **OPEN** the damper, pull the damper rod **FORWARD** (toward the front of the fireplace), then slide **RIGHT** until locked in position.

When the fireplace is **NOT** in use, the damper should remain **CLOSED** to prevent cold air from entering the home through the chimney system.

When the fireplace is in use, the damper **MUST** remain **OPEN**.

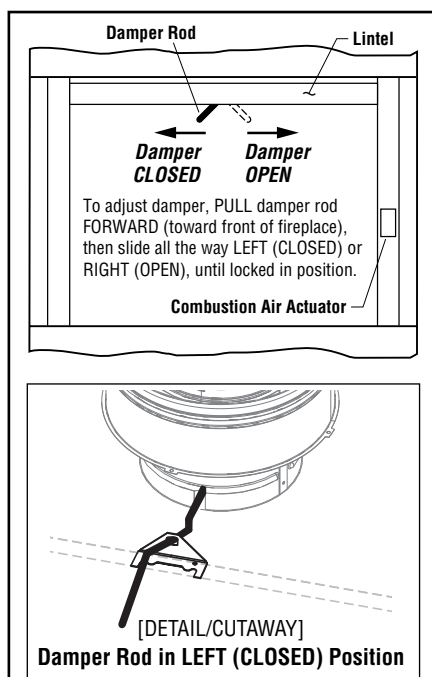

Figure 2

COMBUSTION AIR INLET

This appliance requires the installation of an air inlet for proper operation when installed outdoors.

The fireplace draws air into the chimney and firebox chambers through the air inlet to cool the firebox during operation.

It is important to inspect the air inlet and free it from any obstruction before operating the fireplace (see **Figure 3**).

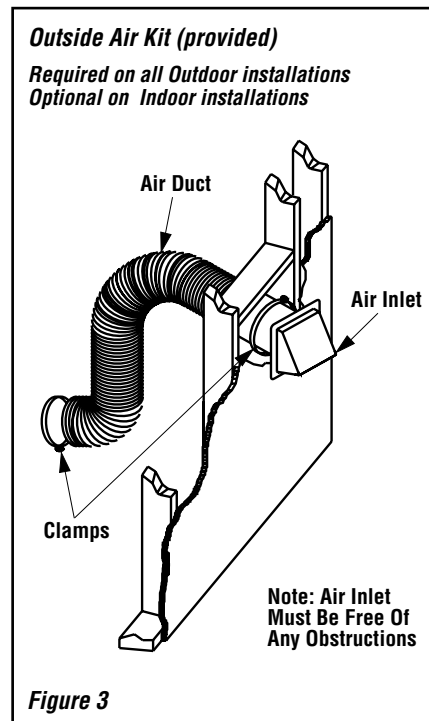

WARNING

Do not operate the fireplace outdoors unless a complete air inlet system has been installed.

AVERTISSEMENT

N'actionnez pas la cheminée dehors à moins qu'un système complet d'entrée d'air ait été installé.

GLASS DOOR OPERATING SAFETY PRECAUTIONS AND INSTRUCTIONS

These fireplaces may be equipped with glass doors. Refer to **Pages 10 and 11** for a list of glass doors approved for use with these fireplaces.

WARNING

If your fireplace is equipped with glass doors, it should be operated with the doors **FULLY OPEN** or **FULLY CLOSED**. If the doors are left partially open, gas and flames may be drawn out of the opening, creating risks of both fire and smoke. Refer to **Figure 4** for proper operating conditions.

AVERTISSEMENT

Les portes du foyer doivent demeurer **TOTALEMENT OUVERTES** ou **TOTALEMENT FERMÉES** lorsque le foyer fonctionne. Si elles sont partiellement ouvertes, il y a un risque d'avoir de la fumée à l'intérieur de la pièce et de provoquer un incendie. Le pare-étincelles optionnel doit être utilisé lorsque le foyer fonctionne avec les portes ouvertes. Référez-vous aux **Figure 4** pour des conditions d'opérations appropriées.

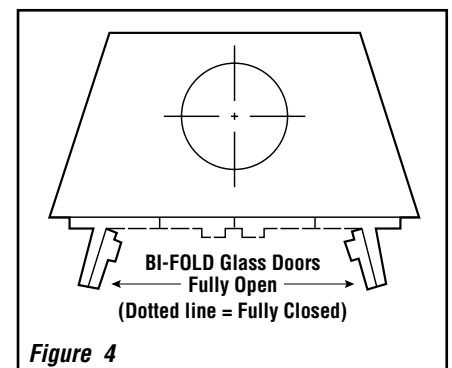

CAUTION

If a smoking condition exists, glass doors should be closed during fireplace operation.

ATTENTION

Si vous apercevez de la fumée qui se dégage du foyer, fermez les portes de verre.

IMPORTANT

See Page 7 for care and cleaning instructions for your glass doors.

ATTENTION

Voir la Page 7 pour les instructions de nettoyage des portes de verre.

COMBUSTION AIR

A proper amount of combustion air is important for your fireplace. Because fireplaces consume large amounts of oxygen, it is important to provide an adequate supply of air.

If the fireplace is not equipped with an outside air kit, it may not obtain a sufficient amount of combustion air from inside the house or structure in which it is installed. When that occurs, the fire may draw air in through the chimney, which can cause smoke spillage into the room.

When smoke spillage occurs, it will begin when the fire is started and continue until the fireplace and chimney have "come up to temperature" and function normally. If smoke spillage problems persist, a window may be opened just a crack to allow the proper flow of combustion air to the fireplace.

If your fireplace is equipped with an outside combustion air kit:

- Keep it OPEN when a fire is burning or smoldering.
- Keep it CLOSED when fire is NOT burning, to prevent cold air intrusion.

Combustion Air Control

All indoor installations must have an optional OAKG Outside Air Kit Gate installed when an Outside Air Kit is installed.

Do NOT operate the actuator for combustion air (Figure 5) unless the complete system has been installed.

If you have reason to believe you do NOT have a complete outside combustion air system, **contact your distributor to have your fireplace inspected for the presence of the complete system BEFORE operating the combustion air actuator.** Do NOT assume your fireplace has a combustion air system installed, even though it has an actuating lever.

WARNING

Do not operate the combustion air gate actuator unless a complete outside combustion air vent system has been installed with your Fireplace.

AVERTISSEMENT

Ne faites pas marcher l'actuateur d'air de combustion à moins qu'un système de bouche d'air de combustion extérieur complet n'ait été installé avec votre Cheminée

The Outside Air Kit Gates are required when an Outside Air Kit is installed on all indoor installations only. They are not approved for use on outdoor installations.

Air Gate Operation Instructions (Indoor Installations Only)

If an Air Gate Kit has been installed (approved for indoor installations only), operate it as follows:

Air Gate Kit (purchased separately)

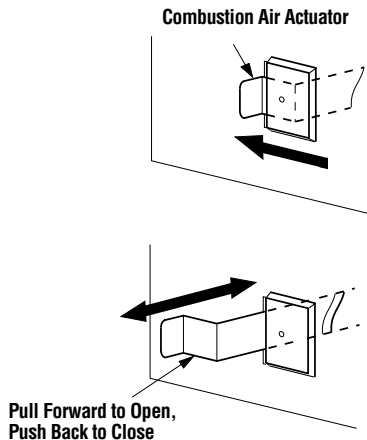

Figure 5

To operate, push the end of the actuator arm to the left, as shown in **Figure 5**, until it "pops" free of its "locked" position.

Pull the actuator forward to open the combustion air door, and push it back to close.

To "lock" the combustion air door closed, ensure the actuator is pushed all the way back, then push the end of the actuators to the right until the step in the actuator moves behind the appliance front face within the slotted opening.

Operate the actuator through several cycles including the "lock" position. Ensuring proper operation and freedom of movement. Return the actuator arm to the locked position.

MAINTENANCE GUIDELINES

Your fireplace is designed to operate trouble-free with minimum maintenance. However, like any fine appliance, it deserves and requires some housekeeping attention.

Your fireplace will perform better if it is cleaned before each use. Before the first seasonal use in Autumn and after the last fire in Spring, it is important to inspect the fireplace system carefully. We recommend at least two complete fireplace inspections a year.

Before Each Use

1. Clean the firebox of excessive ashes. Some owners prefer to leave a small layer to insulate the cold refractory below the grate which helps fire starting.

This fireplace has a factory supplied grate attached, it is permissible to remove the grate for cleaning; however, the grate must be re-attached to the fireplace before the next burn.

2. Keep the fireplace screens clean so combustion air flows freely.
3. Spot check the brick-like refractory for small cracks. Heat from the fire expands it slightly. When it cools, it contracts.

TWICE A YEAR CHECK-UP

Normally, twice a year, you should inspect your fireplace following this list:

1. Inspect the opening in your chimney top and remove any debris that could clog it. The cap is usually held in place by four (4) screws, which remove easily for checking or cleaning the full length of the flue from above. Remove the chimney top while wearing gloves to guard against any sharp metal edges.
2. Inspect the entire flue from the top down for obstructions such as birds nests, leaves, etc. This may be done by using a flexible handled chimney cleaning brush. If the chimney contains offset/return elbows; a soft brush cleaning from the top down to any elbow and then from the firebox up to the offset/return section is the proper method. The beam from a powerful flashlight will help in this inspection.
3. Look up from inside the fireplace (damper open) to see any obstructions in the lower flue area. If present, shut the damper and glass doors (if installed) to seal the firebox and contain any soot that might fall.
4. Check the metal flashing and seals around your chimney. Seal any cracks or loose nailhead openings to prevent roof leaks.
5. Clean the firebox thoroughly by using a soft brush or equivalent.

6. Check outside air inlet and free from any obstructions.
7. Exposed stainless steel face may be cleaned with a solution of baking soda and water: Mix a tablespoon of baking soda in a cup of water and spray on the exposed stainless steel face. Wipe with a clean cloth. For tough stains like smoke and soot stains, use lubricant oil and steel wool (common spray lubricants found where automotive supplies are sold, work well).

Care and Cleaning of Glass Doors

Never clean the glass when the doors are hot. Do not use ammonia or ammonia based glass or household cleaner to clean the glass or the door frame. An ammonia based cleaner will damage the finish of the glass door.

Clean the glass doors by wiping with a damp towel followed by a clean dry towel to remove streaks.

Remove stubborn stains from the glass with a mild soap solution and a towel dampened with clean water. Dry with a clean dry towel.

- Never slam the glass door since it could cause the glass to break.
- Extreme temperature changes can cause glass breakage — do not build a hot fire and close the glass doors if the doors are cold.
- If the tempered glass pane becomes scratched or chipped, it creates a weakness in the glass which can cause the glass to break when heated. Replace the pane of glass by contacting your nearest dealer.

If your fireplace does not have glass doors installed, a damp sheet covering the fireplace opening and sealed with masking tape will do. Then clean the flue from the top down (if an offset system, clean per Step 2) using a proper size chimney brush with flexible pole sections. Don't open the doors or remove the sheet until all soot has settled. Vacuum, don't sweep.



CAUTION

Glass, metal frames, handles and other components of the fireplace get hot. Use handles and wear thermal insulating gloves or other effective protection or tool to open and close the doors or screens.



ATTENTION

Les armatures en métal et le verre deviennent très chauds. Veuillez à toujours utiliser les poignées pour ouvrir et fermer les portes.



WARNING

Be aware that safety glass is unpredictable when hot and may break, expelling hot glass into the room. Advise all family members to remain well away from the fireplace when operating with doors closed to avoid any possible personal injury.



AVERTISSEMENT

Soyez avise que les portes de verre chaudes sont imprévisibles et peuvent se casser, en projetant des morceaux de verre très chauds dans la pièce. Avisez tous les membres de votre famille de demeurer à bonnes distances du foyer lorsqu'il fonctionne avec les portes fermées pour éviter toutes blessures possibles.

CREOSOTE FORMATION AND REMOVAL

When wood is burned slowly, it produces tar and other organic vapors, which combine with expelled moisture to form creosote. The creosote vapors condense in the relatively cool chimney flue of a slow-burning fire. As a result, creosote residue accumulates on the flue lining. When ignited, this creosote makes an extremely hot fire.

The chimney should be inspected at least twice yearly during the heating season to determine if a creosote build-up has occurred.

If creosote has accumulated, it should be removed to reduce the risk of a chimney fire.

If creosote build-up is found, do not use chemical chimney cleaners that are poured on a hot fire. The chemical cleaners can be dangerous and generally only work on the flue section nearest the fire, leaving the rest of the flue unaffected. It is best to take the time to clean the flue as previously described or have the chimney professionally cleaned by a qualified chimney sweep.

REFRACTORIES

All fireboxes contain a furnace refractory floor, back, and sides. Even though these refractories are reinforced with steel, they can be broken from improper use. Dropping logs on the floor refractory or building fires directly against the refractories can cause premature burnout of these components. Refractories may easily be repaired or replaced at costs far below repair and maintenance for traditional masonry fireplaces.

Proper care and “burn-in” of the firebox will prolong refractory life without extensive maintenance. For the first few uses, build small fires; not roaring infernos. The materials used in the refractories contain and absorb moisture. It is important to “cure” the refractories by building only modest fires. Under normal usage, it is expected that hairline cracks will appear in the refractory surface; however, these hairline cracks do not affect the safe operation of the fireplace.

Refractories must be replaced when any of the following conditions occur:

- a 1/4" (19 mm) or larger crack appears; or
- extensive surface pitting occurs (pits deeper than 3/16" (4.76 mm)); or
- any piece of refractory larger than 2" (51 mm) in radius and 3/16" deep becomes dislodged.

STAINLESS STEEL OUTDOOR WEATHER COVER

An optional Stainless Steel Outdoor Weather Cover can be purchased to provide additional protection against leaves and other objects that wind can carry which can accumulate inside your fireplace or damage your fireplace Glass Doors. Complete instructions for use are provided with the cover.

OVERFIRING

- The fire must always be confined within the boundaries of the fuel grate.
- Do not build excessively large or hot fires.
- Extreme temperature changes can cause glass breakage — do not build a hot fire and close the glass doors if the doors are cold.

WARNING

Continued overfiring can permanently damage your fireplace system. Some examples of overfiring are:

- Burning quantities of scrap lumber, pine branches, paper or cardboard boxes which exceed the volume of the normal log fire.
- Burning trash, chemicals or chemically treated combustibles.

AVERTISSEMENT

Si vous surchauffez continuellement votre foyer, vous pourriez l'endommager de façon permanente. Voici quelques exemples:

- Vous brûlez des déchets, du bois de construction, des branches de pins, du papier, des boîtes de carton qui excèdent le volume de feu de bois normal du foyer. Vous risquez sérieusement d'endommager votre système.
- Vous brûlez des substances telles que : enduit protecteur pour le bois, papier métallique, charbon, plastique, rebuts, soufre ou huile vous pourriez gravement endommager votre foyer. Ne brûlez que du bois non-traité.

TROUBLESHOOTING

Note: "Smoke Free" operation is not warranted nor are we responsible for inadequate system draft, general construction conditions, inadequate chimney heights, adverse wind conditions and/or unusual environmental factors or conditions beyond our control.

If you do experience a problem, here are several things to check:

1. Remember – always check to ensure your flue damper is in the open position before lighting a fire!
2. When lighting your fire, a little smoke may escape into the room – more likely if the chimney is cold. To correct this, hold a lighted newspaper up inside the firebox near the open flue damper. This will turn around any downdraft and clear the flue of cold air. As your log fire burns below, the updraft will improve as the chimney heats up.
3. Is your fire too far forward? Move it toward the back with your poker. Keep the fire well within the confines of your fuel grate.
4. Keep your fire up on the grate and the refractory below free of excessive ashes. The fire needs plenty of air movement around the logs.
5. In indoor installations, if smoking occurs an hour or two after lighting the fire, perhaps your well-insulated house is too airtight and there is scarcely any way for replacement air to enter and feed the fire. Check to see if your outside combustion air kit, if installed, is open (see **Figure 3**). Check outside to ensure no obstructions are in front of exterior air entry. Open a window slightly, open doors to one or two rooms and see if this stops the smoking.
6. Is a vent fan, exhaust hood or central heating/cooling system stealing combustion air from your fireplace? If their volume is high enough, this can cause negative pressure and an unwanted downdraft – and smoking.
7. Is your wood fuel too wet or unseasoned? Or does it contain some chemical substance that causes sputtering, smoking and toxic fumes?
8. Is a breeze or wind blowing? This can cause negative pressure and an unwanted downdraft – and smoking.
9. **Figure 6** illustrates the correct height of your chimney top for indoor installations. It is unlikely that your installation does not adhere to the installation instructions. However, if not correct, you could experience an unusual downdraft. Usually, the best solution is to increase the chimney height. This may also be necessary if nearby trees, adjoining roof lines or a hill is causing a downdraft condition.
10. Remember, your fireplace has been designed as a supplemental heating device only, it is not intended to heat your entire home.

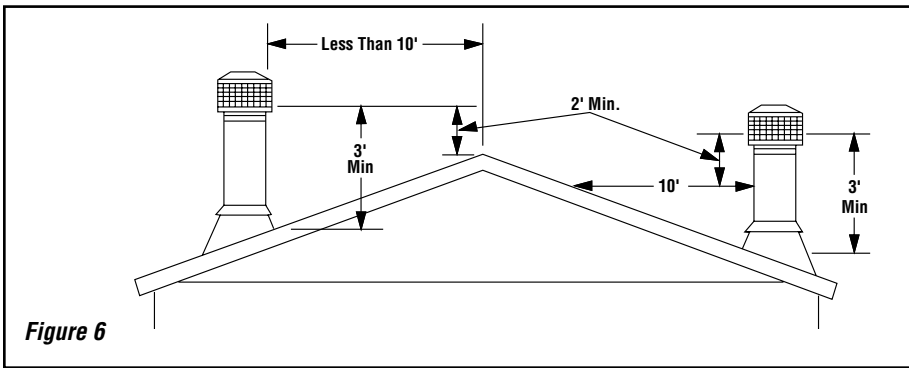

Figure 6

WARRANTY

- This fireplace is covered by a limited warranty detailed separately from this document.
- Retain this manual. File it with your other documents for future reference.

PRODUCT REFERENCE INFORMATION

We recommend that you record the following important information about your fireplace. Please contact your Lennox dealer for any questions or concerns. For the number of your nearest Lennox dealer, please call 1-800-9-LENNOX.

Your Fireplace's Model Number _____

Your Fireplace's Serial Number _____

The Date On Which Your Fireplace Was Installed _____

Your Dealer's Name _____

REPLACEMENT PARTS

A complete parts list is found at the end of this manual. Use only parts supplied from the manufacturer.

Normally, all parts should be ordered through your Lennox distributor or dealer. Parts will be shipped at prevailing prices at time of order.

When ordering repair parts, always give the following information:

1. The model number of the appliance.
2. The serial number of the appliance.
3. The part number.
4. The description of the part.
5. The quantity required.
6. The installation date of the appliance.

ACCESSORY COMPONENTS

Dual Listed (Vented/vent-free) Manual Control Models			
Cat. #	Model	Description	Input
H2053	SHGL-18MN-R	18" Gas Log Set , Natural, Manual	25,000 to 36,000 BTU/HR
H2054	SHGL-18MP-R	18" Gas Log Set , Propane, Manual	27,000 to 36,000 BTU/HR
H2055	SHGL-24MN-R	24" Gas Log Set , Natural, Manual	26,000 to 39,000 BTU/HR
H2056	SHGL-24MP-R	24" Gas Log Set , Propane, Manual	31,000 to 39,000 BTU/HR
Dual Listed (Vented/vent-free) Millivolt Control Models			
H2057	SHGL-18VN-R	18" Gas Log Set , Natural, Millivolt	24,000 to 36,000 BTU/HR
H2058	SHGL-18VP-R	18" Gas Log Set , Propane, Millivolt	24,000 to 36,000 BTU/HR
H2059	SHGL-24VN-R	24" Gas Log Set , Natural, Millivolt	28,000 to 39,000 BTU/HR
H2060	SHGL-24VP-R	24" Gas Log Set , Propane, Millivolt	28,000 to 39,000 BTU/HR

(ref. Form #850,021M)

ACCESSORY COMPONENTS

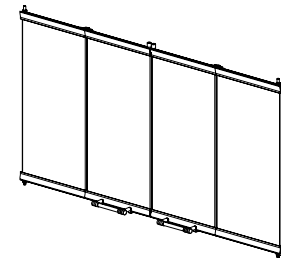

(ref. Form #750,141M)

Brushed Stainless Bi-Fold Door		
Cat. No.	Model No.	Description
H1935	36ABFOD-BS	36" Bi-Fold Door
H1936	42ABFOD-BS	42" Bi-Fold door

Bi-Fold Doors

Your fireplace can be fitted with beautiful bi-fold doors. Stainless Steel Bi-Fold doors are available for use with these fireplace. Doors are easily fitted to the fireplace opening. Use Model 36ABFOD-BS doors with 36 inch fireplaces and Model 42ABFOD-BS doors with 42 inch fireplaces. These doors have a beautiful stainless steel finish.

To ensure warranty and to prevent a potential fire hazard, do not use any other doors on these appliances.

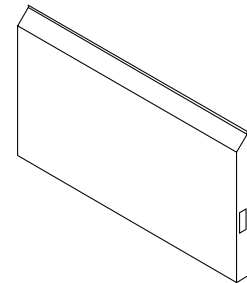

(ref. Form #750,140M)

Brushed Stainless Weather Cover		
Cat. No.	Model No.	Description
H1937	36-ODC	36" Weather Cover
H1938	42-ODC	42" Weather Cover

Brushed Stainless Outdoor Weather Cover

Your fireplace can be fitted with an attractive Stainless Steel Outdoor Weather Cover. This cover is easily fitted to the fireplace opening.

REPLACEMENT PARTS

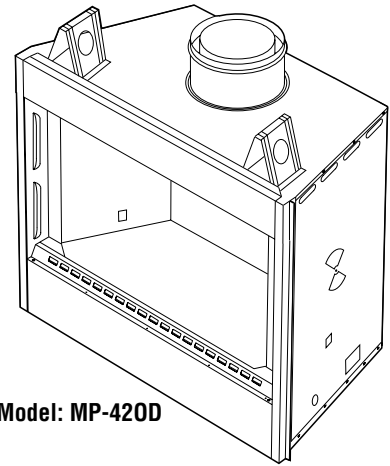
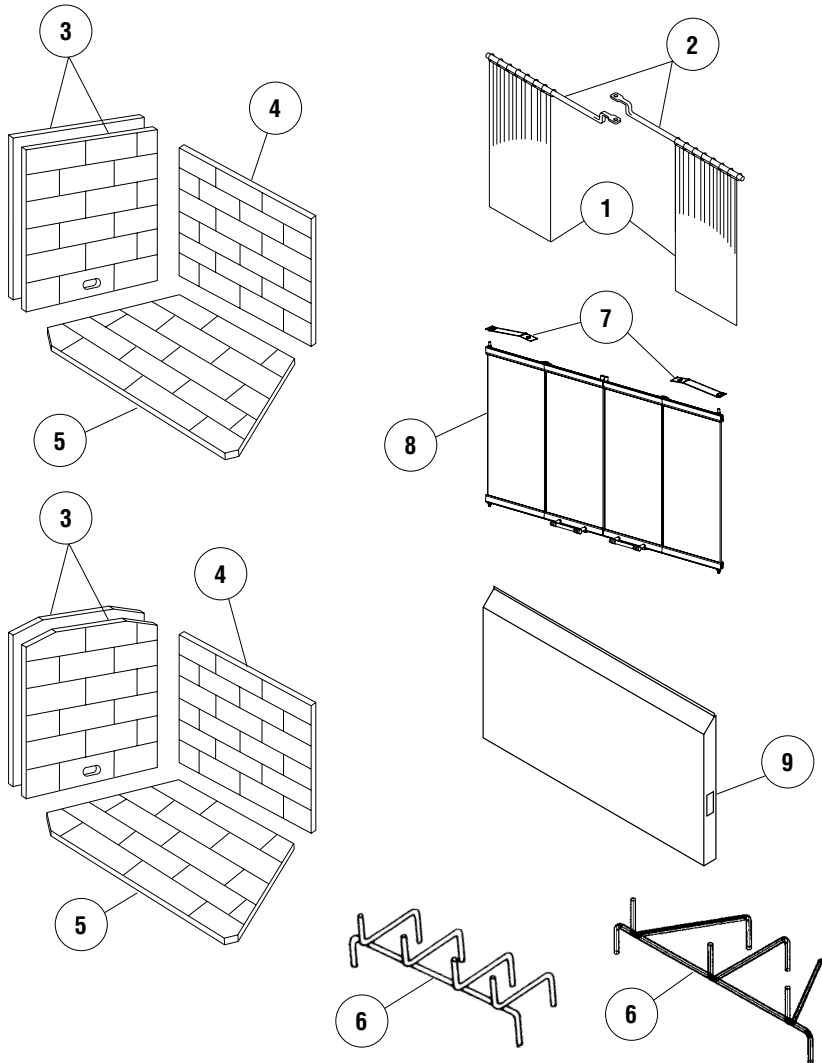

Model: MP-420D

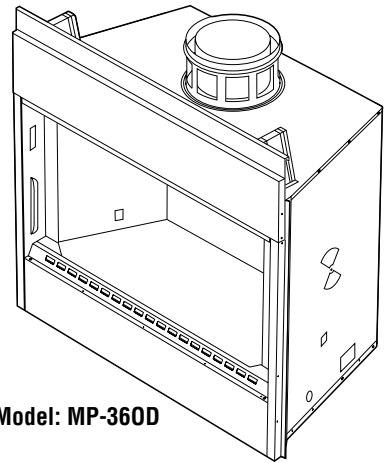

Model: MP-360D

Item No.	Description	Model: MP-360D		Model: MP-420D	
		Part No.	Qty.	Part No.	Qty.
	Wood Fireplace Assembly	H1933	1	H1934	1
1.	Firescreen	H1963	2	H1971	2
2.	Rod, Screen	88L95	2	88L95	2
3.	Refractory, Side	LB-96795	2	LB-96798	2
4.	Refractory, Rear	LB-96796	1	LB-96799	1
5.	Refractory Base	LB-96794	1	LB-96797	1
6.	Grate	H1962	1	H1973	1
7.	Spring, Support	H1965	1	H1965	1
8.	Bi-Fold Door, Brushed Stainless	H1937	1	H1938	1
9.	Weather Cover, Brushed Stainless	H1935	1	H1936	1

NOTE: DIAGRAMS & ILLUSTRATIONS ARE NOT TO SCALE.

The manufacturer reserves the right to make changes at any time, without notice, in design, materials, specifications, and prices, and also to discontinue colors, styles, and products. Consult your local distributor for fireplace code information.



Printed in U.S.A. © 2005/2011 LENNOX HEARTH PRODUCTS
P/N 875029M Rev. B 10/2011

1508 Elm Hill Pike, Suite 108 • Nashville, TN 37210