

This Owner's Manual is provided and hosted by Appliance Factory Parts.

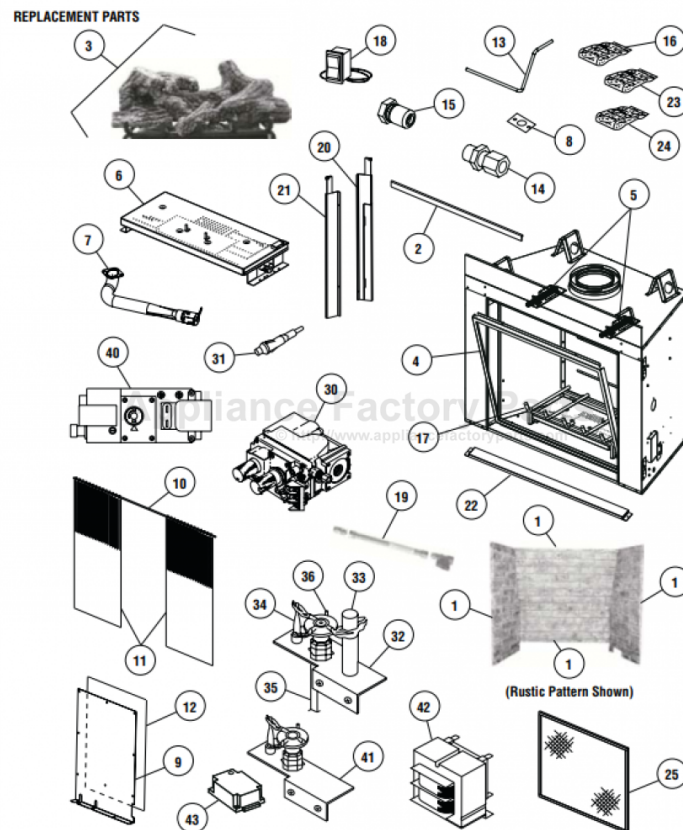

LENNOX HEARTH LSM40EN-2 Owner's Manual

[Shop genuine replacement parts for LENNOX HEARTH
LSM40EN-2](#)



[Find Your LENNOX HEARTH Fireplace Parts - Select From 237 Models](#)

----- Manual continues below -----



HEARTH PRODUCTS

This appliance may be installed in an aftermarket permanently located, manufactured home (USA only) or mobile home, where not prohibited by local codes. This appliance is only for use with the type of gas indicated on the rating plate. This appliance is not convertible for use with other gases, unless a certified kit is used.

In the Commonwealth of Massachusetts:

- Installation must be performed by a licensed plumber or gas fitter;
- See Table of Contents for location of additional Commonwealth of Massachusetts requirements.

A French manual is available upon request. Order P/N 850,026CF

Ce manuel d'installation est disponible en français, simplement en faire la demande. Numéro de la pièce 850,026CF.

WARNING: IF THE INFORMATION IN THIS MANUAL IS NOT FOLLOWED EXACTLY, A FIRE OR EXPLOSION MAY RESULT CAUSING PROPERTY DAMAGE, PERSONAL INJURY OR LOSS OF LIFE.

FOR YOUR SAFETY: Do not store or use gasoline or other flammables or liquids in the vicinity of this or any other appliance.

FOR YOUR SAFETY: What to do if you smell gas:

- **DO NOT** light any appliance.
- **DO NOT** touch any electrical switches.
- Do not use any phone in your building.
- Immediately call your gas supplier from a neighbor's phone. Follow your gas suppliers instructions.
- If your gas supplier cannot be reached, call the fire department.

Installation and service must be performed by a qualified installer, service agency or the gas supplier.

Tested &
Listed By  Beaverton
Oregon USA
OMNI-Test Laboratories, Inc.

OTL Report No. 116-F-22-5

INSTALLATION INSTRUCTIONS

DIRECT VENT MONTEBELLO™

DAVE LENNOX
signature
COLLECTION

VENTED GAS FIREPLACE - DIRECT VENT MODELS
P/N 850,026M REV. D 08/2007

MODELS

Millivolt Models

LSM40MN-2
LSM40MP-2
LSM45MN-2
LSM45MP-2

Electronic Models

LSM40EN-2
LSM45EN-2

INSTALLER: Leave this manual with the appliance.
CONSUMER: Retain this manual for future reference.

AVERTISSEMENT: ASSUREZ-VOUS DE BIEN SUIVRE LES INSTRUCTIONS DONNÉ DANS CETTE NOTICE POUR RÉDUIRE AU MINIMUM LE RISQUE D'INCENDIE OU POUR ÉVITER TOUT DOMMAGE MATÉRIEL, TOUTE BLESSURE OU LA MORT.

POUR VOTRE SÉCURITÉ: Ne pas entreposer ni utiliser d'essence ni d'autre vapeurs ou liquides inflammables dans le voisinage de cet appareil ou de tout autre appareil.

POUR VOTRE SÉCURITÉ: Que faire si vous sentez une odeur de gaz:

- Ne pas tenter d'allumer d'appareil.
- Ne touchez à aucun interrupteur. Ne pas vous servir des téléphones se trouvant dans le bâtiment où vous vous trouvez.
- Evacuez la pièce, le bâtiment ou la zone.
- Appelez immédiatement votre fournisseur de gaz depuis un voisin. Suivez les instructions du fournisseur.
- Si vous ne pouvez rejoindre le fournisseur de gaz, appelez le service des incendies.

L'installation et service doit être exécuté par un qualifié installateur, agence de service ou le fournisseur de gaz.

TABLE OF CONTENTS

Packaging	Page 2
Introduction	Page 2
General Information	Page 2
New York & Massachusetts	
Requirements.....	Page 4
Location.....	Page 5
Appliance and Vent Clearances	Page 5
Vent Termination Clearances	Page 6
Typical Installation Sequence	Page 6
Detailed Installation Steps.....	Page 6
Step 1. Framing.....	Page 6
Step 2. Routing Gas Line	Page 6
Fireplace Specifications.....	Page 8
Step 3. Install the Vent System	Page 10
Vertical Termination Systems.....	Page 10
Vent Section Length Chart	Page 11
Vertical Vent Tables and Figures.....	Page 13
Horizontal Termination System	Page 15
Horizontal Vent Tables and Figures ...	Page 17
Step 4. Field Wiring.....	Page 19
Step 5. Removing Glass Door	
Frame Assembly	Page 20
Step 6. Connecting Gas Line	Page 20
Step 7. Installing Logs	Page 20
Step 8. Checking Appliance	
Operation	Page 21
Step 9. Installing Glass Door	Page 21
Step 10. Burner Adjustments	Page 21
Finishing Requirements	Page 22
Cold Climate Insulation	Page 24
Installation Accessories	Page 24
Gas Conversion Kits	Page 26

This installation manual will help you obtain a safe, efficient, dependable installation for your appliance and vent system.

Please read and understand these instructions before beginning your installation.



We recommend that our gas hearth products be installed and serviced by professionals who are certified in the U.S. by the National Fireplace Institute® (NFI) as NFI Gas Specialists.

PACKAGING

The assembled vented gas fireplace is packaged with:

- 1 - one envelope located in the firebox containing the literature package, which consists of the Care and Operation Manual, Installation Instructions, Log Placement Guide and Warranty
- 2- A bag of glowing embers and Lava Rock
- 3 - one of the following brick liner kits:
 - a. Brick Liner Kit, Rustic
 - b. Brick Liner Kit, Herringbone
 - c. Brick Liner Kit, Old Cottage
 - d. Brick Liner Kit, Black.
 - e. Brick Liner Kit, Red Rustic
 - f. Brick Liner Kit, Red Herringbone
- 4 - one of the following log sets:
 - a. Birch Log set
 - b. Oak Log set
- 5 - pull screen
- 6 - door modesty shield

INTRODUCTION

These vented gas fireplaces are sealed combustion gas fireplaces designed for residential applications. These appliances must be installed with the **Secure Vent™** vent systems routed to the outside atmosphere.

Millivolt appliances are designed to operate on natural or propane gas. A millivolt gas control valve with piezo ignition system provides safe and efficient operation.

Electronic appliances are designed to operate on natural gas or propane. An electronic intermittent pilot ignition system provides safe, efficient operation. External electrical power is required to operate these units.

These appliances comply with National Safety Standards and are tested and listed by OMNI-Test Laboratories (Report No. 116-F-22-5) to ANSI Z21.50 (in Canada, CSA-2.22), and CAN/CGA-2.17-M91 in both USA and Canada, as vented gas fireplace.

Both millivolt and electronic versions of these appliances are listed by OMNI-Test Laboratories for installation in bedrooms and mobile homes.

The Installation must conform to local codes or, in the absence of local codes, with the *National Fuel Gas Code, ANSI Z223.1/NFPA 54 - latest edition*, or the *Natural Gas and Propane Installation Code, CSA B149.1*.

The appliance, when installed, must be electrically grounded in accordance with local codes or, in the absence of local codes, with the *National Electrical Code, ANSI/NFPA 70*, or the *Canadian Electrical Code, CSA C22.1*.

DO NOT ATTEMPT TO ALTER OR MODIFY THE CONSTRUCTION OF THE APPLIANCE OR ITS COMPONENTS. ANY MODIFICATION OR ALTERATION MAY VOID THE WARRANTY, CERTIFICATION AND LISTINGS OF THIS UNIT.

GENERAL INFORMATION

Note: Installation and repair should be performed by a qualified service person. The appliance should be inspected annually by a qualified professional service technician. More frequent inspections and cleaning may be required due to excessive lint from carpeting, bedding material, etc. It is imperative that the control compartment, burners and circulating air passage ways of the appliance be kept clean.

S'assurer que le brûleur et le compartiment des commandes sont propres. Voir les instructions d'installation et d'utilisation qui accompagnent l'appareil.

Provide adequate clearances around air openings and adequate accessibility clearance for service and proper operation. Never obstruct the front openings of the appliance.

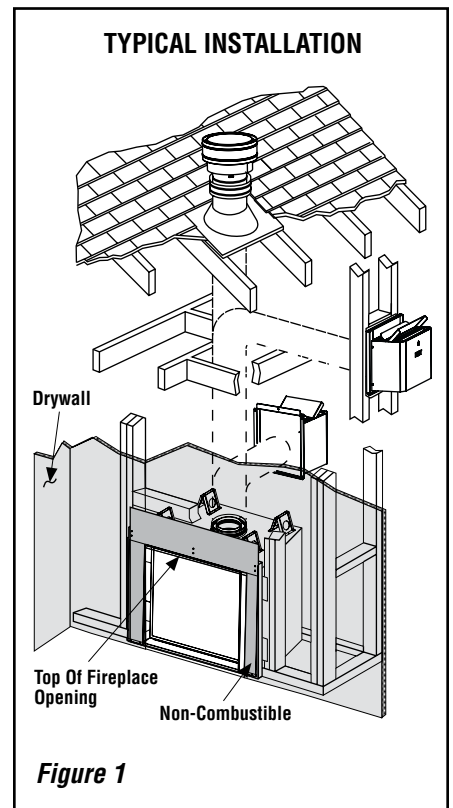

NOTE: DIAGRAMS & ILLUSTRATIONS ARE NOT TO SCALE.

These appliances are designed to operate on natural or propane gas only.

Millivolt Models -

Millivolt models come standard with the manually-modulated gas valve; flame appearance and heat output can be controlled at the gas valve.

Input of millivolt models is shown in the following table:

Millivolt Models with Manually-Modulated Gas Valve	
Model No.	Input (BTU/Hr)
Natural Gas	
LSM40MN-2	40,000 to 50,000
LSM45MN-2	47,000 to 60,000
Propane Gas	
LSM40MP-2	40,000 to 50,000
LSM45MP-2	48,000 to 60,000

Table 1

Electronic Models -

Electronic models have a manually modulated gas valve. Input of electronic models is shown in the following table:

Electronic Models with Manually-Modulated Gas Valve	
Model No.	Input (BTU/Hr)
Natural Gas	
LSM40EN-2	40,000 to 50,000
LSM45EN-2	47,000 to 60,000
Propane Gas	
LSM40EP-2*	40,000 to 50,000
LSM45EP-2*	48,000 to 60,000

Table 2 * If field converted to propane

All Models -

Maximum manifold pressure is 3.5 in. w.c. (0.87 kPa) for natural gas and 10 in. w.c. (2.49 kPa) for LP/Propane gas.

Installations at altitudes of 0 to 4500 ft.- Units are tested and approved for elevations of 0 to 4500 feet (0 to 1372 meters).

Installations at altitudes above 4500 ft.- For elevations above 4500 feet (1372 meters), install the unit according to the regulations of the local authorities having jurisdiction and, in the USA, the latest edition of the National Fuel Gas Code (ANSI Z223.1) or, in Canada, the latest edition of the CAN1-B149.1 and .2 codes.

Table 3 shows the gas orifice size required for the elevations indicated.

Model	Orifice Size		Elevation Feet (meters)
	Nat.	Prop.	
LSM40-2	.1405" (#28)	.086" (#44)	0-4500 (0-1372)
LSM45-2	.161" (#20)	.093" (#42)	

Table 3

The millivolt appliances are manually controlled and feature a spark igniter (piezo) that allows the appliance's pilot gas to be lit without the use of matches or batteries. This system provides continued service in the event of a power outage.

Do not use these appliances if any part has been under water. Immediately call a qualified, professional service technician to inspect the appliance and to replace any parts of the control system and any gas control which have been under water.

Ne pas se servir de cet appareil s'il a été plongé dans l'eau, complètement ou en partie. Appeler un technicien qualifié pour inspecter l'appareil et remplacer toute partie du système de contrôle et toute commande qui ont été plongés dans l'eau.

This appliance may be installed in an aftermarket permanently located, manufactured home (USA only) or mobile home, where not prohibited by local codes. This appliance is only for use with the type of gas indicated on the rating plate. This appliance is not convertible for use with other gases, unless a certified kit is used.

Cet appareil peut être installé dans un maison préfabriquée (É.-U. seulement) ou mobile déjà installée à demeure si les règlements locaux le permettent.

Cet appareil doit être utilisé uniquement avec les types de gaz indiqués sur la plaque signalétique. Ne pas l'utiliser avec d'autres gaz sauf si un kit de conversion certifié est installé.

Test gauge connections are provided on the front of the millivolt and electronic gas control valve (identified IN for the inlet and OUT for the manifold side).

Minimum inlet gas pressure to these appliances is 5.5 inches water column (1.37 kPa) for natural gas and 11 inches water column (2.74 kPa) for propane for the purpose of input adjustment.

Maximum inlet gas supply pressure to these appliances is 10.5 inches water column (2.61 kPa) for natural gas and 13.0 inches water column (3.23 kPa) for propane.

These appliances must be isolated from the gas supply piping system (by closing their individual manual shut-off valve) during any pressure testing of the gas supply piping system at test pressures equal to or less than 1/2 psig (3.5 kPa).

These appliances and their individual shut-off valves must be disconnected from the gas supply piping system during any pressure testing of that system at pressures in excess of 1/2 psig (3.5 kPa).

These appliances must not be connected to a chimney or flue serving a separate solid fuel burning appliance.

Carbon Monoxide Poisoning: Early signs of carbon monoxide poisoning are similar to the flu with headaches, dizziness and/or nausea. If you have these signs, obtain fresh air immediately. Have the appliance serviced by a qualified technician as it may not be operating correctly. Some people are more affected by carbon monoxide than others. These include pregnant women, people with heart or lung disease or anemia, those under the influence of alcohol, and those at high altitudes.

New York City, New York (MEA)

Installation of these fireplaces are approved for installation in New York City in the US state of New York.

Requirements for the Commonwealth of Massachusetts

Note: The following requirements reference various Massachusetts and national codes not contained in this document.

For all side wall horizontally vented gas fueled equipment installed in every dwelling, building or structure used in whole or in part for residential purposes, including those owned or operated by the Commonwealth and where the side wall exhaust vent termination is less than seven (7) feet above finished grade in the area of the venting, including but not limited to decks and porches, the following requirements shall be satisfied:

Installation Of Carbon Monoxide Detectors

At the time of installation of the side wall horizontal vented gas fueled equipment, the installing plumber or gasfitter shall observe that a hard wired carbon monoxide detector with an alarm and battery back-up is installed on the floor level where the gas equipment is to be installed. In addition, the installing plumber or gasfitter shall observe that a battery operated or hard wired carbon monoxide detector with an alarm is installed on each additional level of the dwelling, building or structure served by the side wall horizontal vented gas fueled equipment. It shall be the responsibility of the property owner to secure the services of qualified licensed professionals for the installation of hard wired carbon monoxide detectors.

In the event that the side wall horizontally vented gas fueled equipment is installed in a crawl space or an attic, the hard wired carbon monoxide detector with alarm and battery back-up may be installed on the next adjacent floor level.

In the event that the requirements of this subdivision can not be met at the time of completion of installation, the owner shall have a period of thirty (30) days to comply with the above requirements; provided, however, that during said thirty (30) day period, a battery operated carbon monoxide detector with an alarm shall be installed.

Approved Carbon Monoxide Detectors

Each carbon monoxide detector as required in accordance with the above provisions shall comply with NFPA 720 and be ANSI/UL 2034 listed and IAS certified.

Signage

A metal or plastic identification plate shall be permanently mounted to the exterior of the building at a minimum height of eight (8) feet above grade directly in line with the exhaust vent terminal for the horizontally vented gas fueled heating appliance or equipment. The sign shall read, in print size no less than one-half (1/2) inch in size, **“GAS VENT DIRECTLY BELOW. KEEP CLEAR OF ALL OBSTRUCTIONS.”**

Inspection

The state or local gas inspector of the side wall horizontally vented gas fueled equipment shall not approve the installation unless, upon inspection, the inspector observes carbon monoxide detectors and signage installed in accordance with the provisions of 248 CMR 5.08(2)(a)1 through 4.

Exemptions

The following equipment is exempt from 248 CMR 5.08(2)(a)1 through 4:

- The equipment listed in Chapter 10 entitled “Equipment Not Required To Be Vented” in the most current edition of NFPA 54 as adopted by the Board; and
- Product Approved side wall horizontally vented gas fueled equipment installed in a room or structure separate from the dwelling, building or structure used in whole or in part for residential purposes.

MANUFACTURER REQUIREMENTS

Gas Equipment Venting System Provided

When the manufacturer of Product Approved side wall horizontally vented gas equipment provides a venting system design or venting system components with the equipment, the instructions provided by the manufacturer for installation of the equipment and the venting system shall include:

- Detailed instructions for the installation of the venting system design or the venting system components; and
- A complete parts list for the venting system design or venting system.

Gas Equipment Venting System NOT Provided

When the manufacturer of a Product Approved side wall horizontally vented gas fueled equipment does not provide the parts for venting the flue gases, but identifies “special venting systems”, the following requirements shall be satisfied by the manufacturer:

- The referenced “special venting system” instructions shall be included with the appliance or equipment installation instructions; and
- The “special venting systems” shall be Product Approved by the Board, and the instructions for that system shall include a parts list and detailed installation instructions.

A copy of all installation instructions for all Product Approved side wall horizontally vented gas fueled equipment, all venting instructions, all parts lists for venting instructions, and/or all venting design instructions shall remain with the appliance or equipment at the completion of the installation.

- Installation and repair must be done by a plumber or gas fitter licensed in the Commonwealth of Massachusetts.
- The flexible gas line connector used shall not exceed 36 inches (92 centimeters) in length.
- The individual manual shut-off must be a T-handle type valve.

⚠ WARNING

Failure to comply with the installation and operating instructions provided in this document will result in an improperly installed and operating appliance, voiding its warranty. Any change to this appliance and/or its operating controls is dangerous. Improper installation or use of this appliance can cause serious injury or death from fire, burns, explosion or carbon monoxide poisoning.

⚠ WARNING

Children and adults should be alerted to the hazards of high surface temperatures. Use caution around the appliance to avoid burns or clothing ignition. Young children should be carefully supervised when they are in the same room as the appliance.

Note: An Optional Screen Door or Screen Panel for the glass is available (see Care and Operations Manual for ordering information).

⚠ WARNING

Do not place clothing or other flammable materials on or near this appliance.

⚠ AVERTISSEMENT

Surveiller les enfants. Garder les vêtements, les meubles, l'essence ou autres liquides à vapeur inflammables loin de l'appareil.

LOCATION

In selecting the location, the aesthetic and functional use of the appliance are primary concerns. However, vent system routing to the exterior and access to the fuel supply are also important. Consideration should be given to traffic ways, furniture, draperies, etc., due to elevated surface temperatures (*Figure 2*). The location should also be free of electrical, plumbing or other heating/air conditioning ducting.

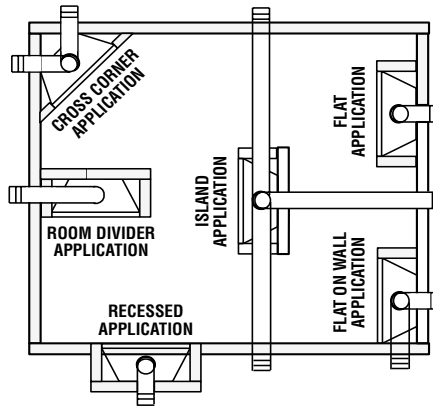
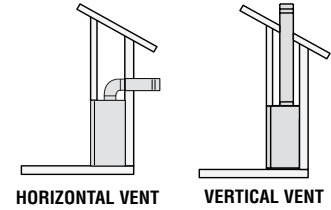

Figure 2



Typical Locations

Do not insulate the space between the appliance and the area above it. See *Figure 3*. The minimum height from the base of the appliance to the underside of combustible materials used to construct a utility shelf in this fashion is shown in the table in *Figure 3*.

The appliance should be mounted on a fully supported base extending the full width and depth of the unit. The appliance may be located on or near conventional construction materials. However, if installed on combustible materials, such as carpeting, vinyl tile, etc., a metal or wood barrier covering the entire bottom surface must be used.

MINIMUM VENTING CLEARANCES Inches (millimeters)	
Vertical Sections	
Sides	1" (25 mm)
Horizontal Sections	
Top	3" (75 mm)
Bottom	1" (25 mm)
Sides	1" (25 mm)
Vertical Vent Applications	
Sides	1" (25 mm)

Table 4

APPLIANCE MINIMUM CLEARANCES* Inches (millimeters)	
Back	1/2 (13) 0 (0) Spacers
Sides	1/2 (13) 0 (0) Spacers
Top Spacers	0 (0)
Floor	0 (0)
Bottom of Appliance To Ceiling	69 (1743)

Table 5

*Note: See *Page 6, Step 1* for clearance requirements to the nailing flange located at each side of the unit and any screw heads adjacent to it.

APPLIANCE AND VENT CLEARANCES

The appliance is approved with zero clearance to combustible materials on all sides (as detailed in *Table 5*), with the following exception: When the unit is installed with one side flush with a wall, the wall on the other side of the unit must not extend beyond the front edge of the unit. In addition, when the unit is recessed, the side walls surrounding the unit must not extend beyond the front edge of the unit. See *Figure 2*.

Model No.	Combustible Shelf Height Inches (millimeters)
	Top Vent - with 2 Feet Vertical Vent and One 90 Degree Elbow
	Secure Vent
LSM40-2	*84-1/16 (2135)
LSM45-2	89-1/16 (2252)

* Includes 3" clearance to combustibles (required above vent components)

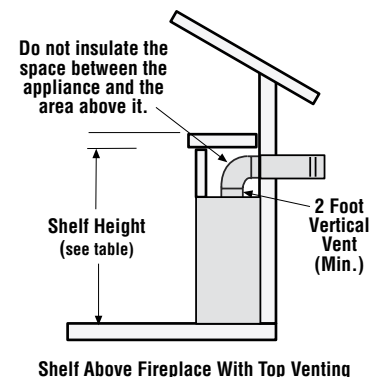

Figure 3

NOTE: DIAGRAMS & ILLUSTRATIONS ARE NOT TO SCALE.

VENT TERMINATION CLEARANCES

These instructions should be used as a guideline and do not supersede local codes in any way. Install vent according to local codes, these instructions, the current National Fuel Gas Code (ANSI-Z223.1) in the USA or the current standards of CAN/CGA-B149.1 and -B149.2 in Canada.

Vertical Vent Termination Clearances

Terminate single vent caps relative to building components according to **Figure 4**.

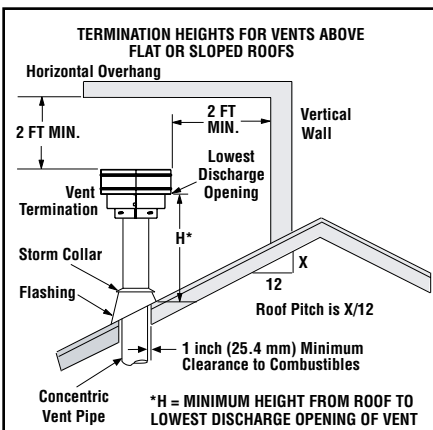

The vent / air intake termination clearances above the high side of an angled roof is as shown in the following chart:

Termination Heights For Vents Above Flat Or Sloped Roofs Ref. NFPA 54 / ANSI Z223.1, 7.6		
Roof Pitch	* Feet	* Meters
Flat to 6/12	1.0	0.3
6/12 to 7/12	1.25	0.38
7/12 to 8/12	1.5	0.46
8/12 to 9/12	2.0	0.61
9/12 to 10/12	2.5	0.76
10/12 to 11/12	3.25	0.99
11/12 to 12/12	4.0	1.22

Figure 4

Terminate multiple vent terminations according to the installation codes listed at the top of **this Page**.

Horizontal Vent Termination Clearances

The horizontal vent termination must have a minimum of 3" (76 mm) clearance to any overhead combustible projection of 2-1/2" (64 mm) or less. See **Figure 5**. For projections exceeding 2-1/2" (64 mm), see **Figure 5**. For additional vent location restrictions refer to **Figure 8 on Page 7**.

TYPICAL INSTALLATION SEQUENCE

The typical sequence of installation follows, however, each installation is unique resulting in variations to those described.

See the Page numbers references in the following steps for detailed procedures.

Step 1. (Page 6) Construct the appliance framing. Position the appliance within the framing and secure with nailing brackets.

Step 2. (Page 6) Route gas supply line to the right side of the appliance.

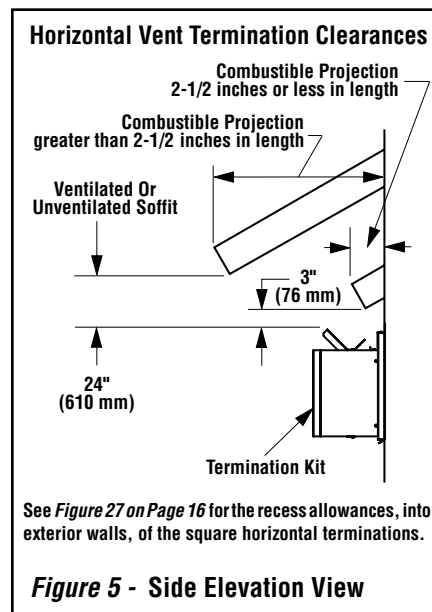

Figure 5 - Side Elevation View

Step 3. (Page 10) Install the vent system and exterior termination.

Step 4. (Page 19) Field Wiring

a. Millivolt and Electronic Appliances – The operating control switch is factory installed.

b. Electronic Appliances – Connect 120 Vac electrical power to the appliance receptacle.

Step 5. (Page 20) Remove glass door frame assembly.

Step 6. (Page 20) Make connection to gas supply.

Step 7. (Page 20) Install ceramic panels, logs and glowing embers.

Step 8. (Page 21) Checkout appliance operation.

Step 9. (Page 21) Install glass door frame assembly.

Step 10. (Page 21) Adjust burner to ensure proper flame appearance.

DETAILED INSTALLATION STEPS

The appliance is shipped with all gas controls and components installed and pre-wired. Remove the shipping carton, exposing the front glass door. Using a Phillips screwdriver, unfasten two (2) screws located at the top of the glass frame (see **Figure 37**). Tilt the top of the glass frame away from the unit. Lift it carefully off the bottom door track and set the door aside, protecting it from inadvertent damage.

Step 1. FRAMING

Frame these appliances as illustrated in **Figure 9 on Page 8**, unless the appliance is to be installed in a corner. See **Figure 10 on Page 8** for corner framing installations. All framing details must allow for a minimum clearance to combustible framing members as shown in **Table 5 on Page 5**.

the appliance is to be elevated above floor level, a solid continuous platform must be constructed.

Headers may be in direct contact with the appliance top spacers but must not be supported by them or notched to fit around them. All construction above the appliance must be self supporting, **DO NOT** use the appliance for structural support.

The fireplace should be secured to the side framing members using the unit's nailing flanges - one top and bottom on each side of the fireplace front. See **Figure 6**. Use 8d nails or their equivalent.

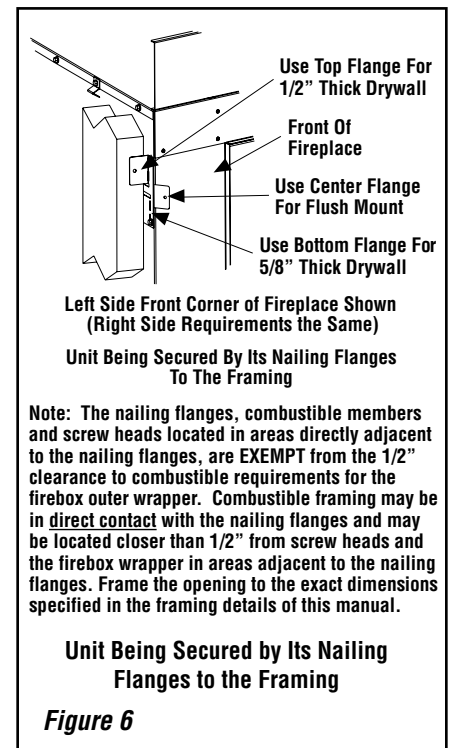

Figure 6

Step 2. ROUTING GAS LINE

Route a 1/2" (13 mm) gas line along the inside of the right side framing as shown in **Figure 7**. Gas lines must be routed, constructed and made of materials that are in strict accordance with local codes and regulations.

All appliances are factory-equipped with a flexible gas line connector and 1/2 inch shutoff valve. (See **Step 5 on Page 20**).

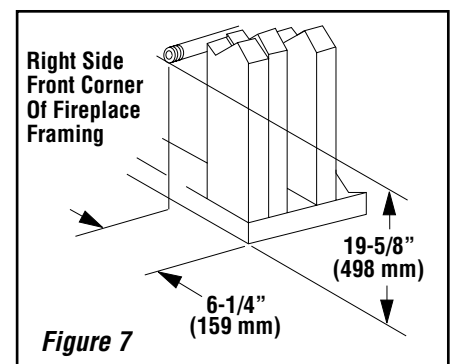
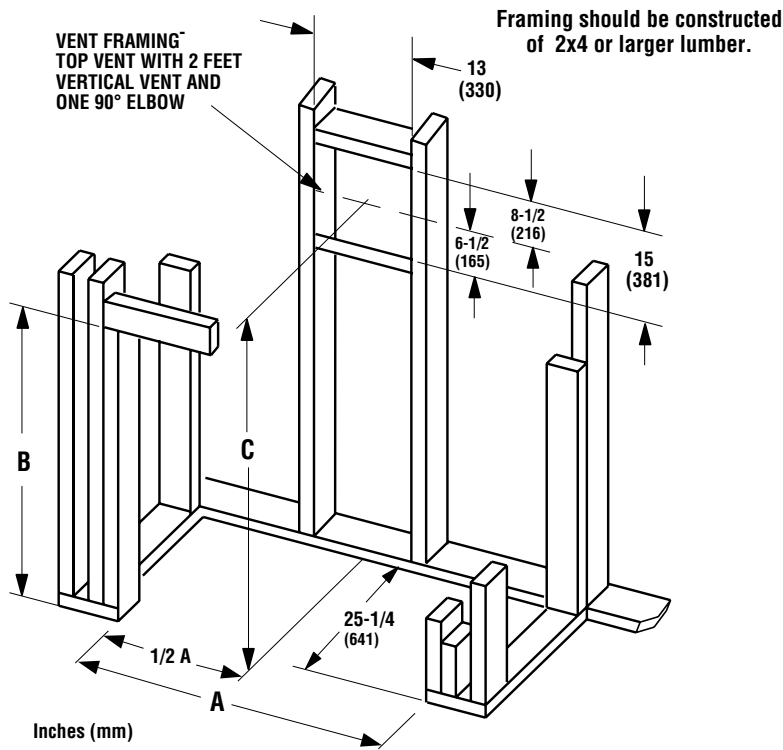

Figure 7

FIREPLACE FRAMING SPECIFICATIONS



Model No.		A	B	C
LSM40-2	in.	50-3/4	43	75-1/8
	mm	1289	1092	1908
LSM45-2	in.	56-7/8	48	80-1/16
	mm	1445	1219	2034

Figure 9 Framing

Model No.		A	B	C	D
LSM40-2	in.	50-5/8	83-5/8	59-1/8	41-7/8
	mm	1286	2124	1502	1064
LSM45-2	in.	56-3/4	89-7/8	63-1/2	44-7/8
	mm	1441	2283	1613	1140

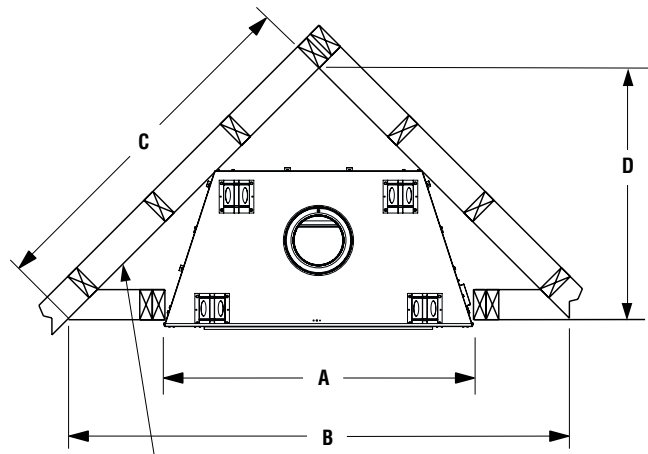

Back wall of chase/enclosure (including any finishing materials)

Figure 10 Corner Framing with Square Termination (SV8HTS)

FIREPLACE SPECIFICATIONS

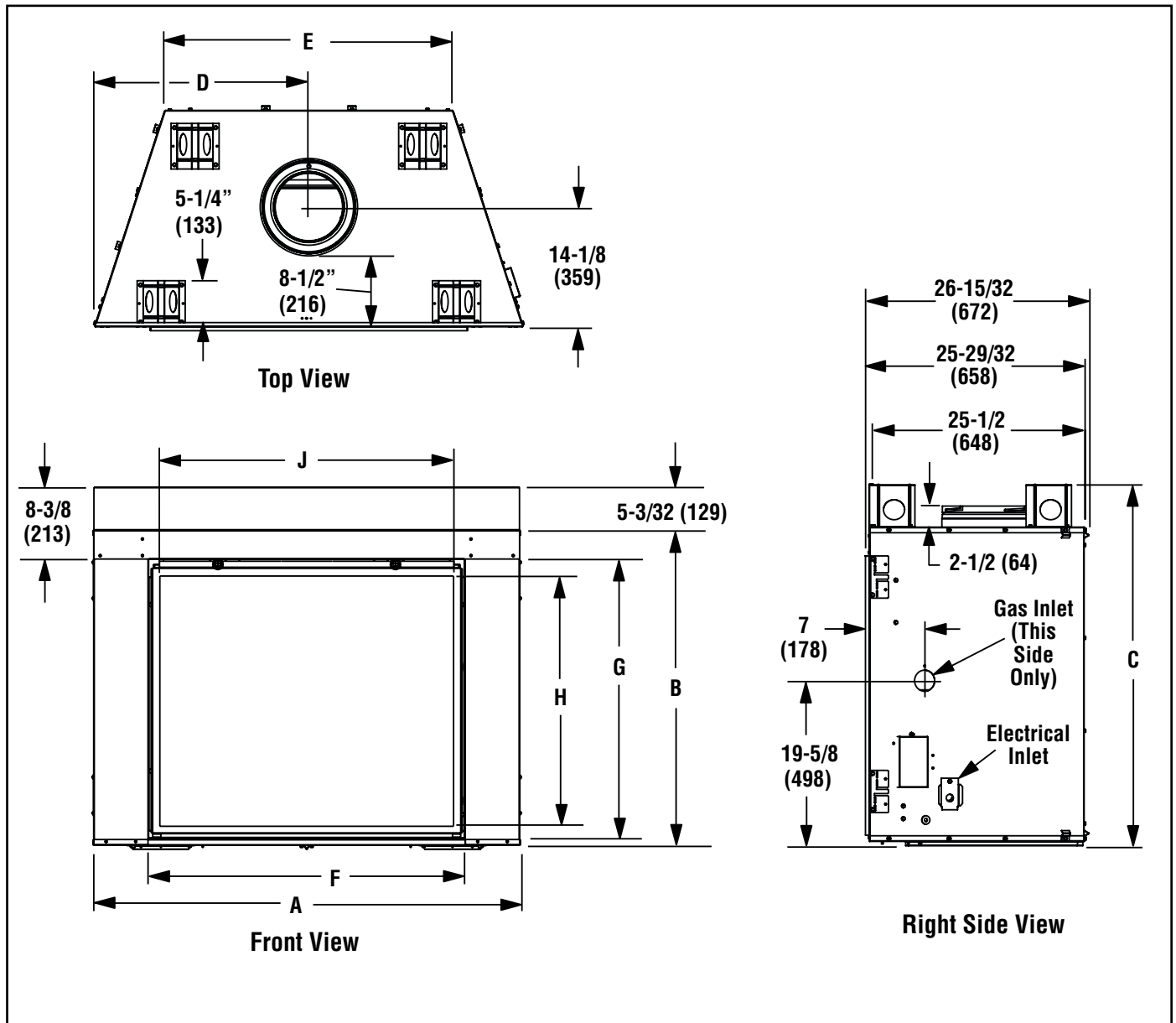

Unit Dimensions

Model No.		A	B	C	D	E	F	G	H	J
LSM40-2	in.	50-5/8	37-1/4	42-7/8	25-5/16	34	37-5/8	33-3/32	29-9/32	34-3/4
	mm	1286	946	1089	643	864	956	840	744	883
LSM45-2	in.	56-11/16	42-1/4	47-7/8	28-3/8	40-1/8	43-5/8	38-3/32	34-1/2	40-59/64
	mm	1440	1073	1216	721	1019	1108	968	876	1039

Figure 11

Step 3. INSTALL THE VENT SYSTEM

General Information

These instructions should be used as a guideline and do not supersede local codes in any way. Install vent according to local codes, these instructions, the current National Fuel Gas Code (ANSI-Z223.1) in the USA or the current standards of CAN/CGA-B149.1 and -B149.2 in Canada.

These fireplaces are designed, tested and listed for operation and installation with, and only with, Secure Vent™ (SV8) Direct Vent System Components, manufactured by Security Chimneys International. These approved vent system components are labeled for identification. **DO NOT** use any other manufacturer's vent components with these appliances.

These fireplaces must be vented directly to the outside.

The vent system may not service multiple appliances, and must never be connected to a flue serving a solid fuel burning appliance. The vent pipe is tested to be run inside an enclosing wall (such as a chase). There is no requirement for inspection openings in the enclosing wall at any of the joints in the vent pipe.

Select Venting System - Horizontal or Vertical

With the appliance secured in framing, determine vent routing and identify the exterior termination location. The following sections describe vertical (roof) and horizontal (exterior wall) vent applications. Refer to the section relating to your installation. **A list of approved venting components is shown on Pages 24 and 25.**

VERTICAL TERMINATION SYSTEMS (ROOF)

Figures 12A, 12B on Page 10 and Figures 22 through 24 on Pages 13 and 14 and their associated Vertical Vent Tables illustrate the various vertical venting configurations that are possible for use with these appliances. A Vertical Vent Table summarizes each system's minimum and maximum vertical and horizontal length values that can be used to design and install the vent components in a variety of applications.

The vertical vent system terminates through the roof. The minimum vent height above the roof and/or adjacent walls is specified in ANSI Z223.1-(latest edition) (In Canada, the current CAN-1 B149 installation code) by major building codes. Always consult your local codes for specific requirements. A general guide to follow is the Gas Vent Rule (refer to **Figure 4 on Page 6**).

For vertical venting from 6 feet to 12 feet or more, from the top of the fireplace to the top of the termination, the installation of a vent restrictor is required.

Install a vent restrictor (provided) in the appliance flue outlet as shown in **Figure 12A**. It is held in place by friction, only.

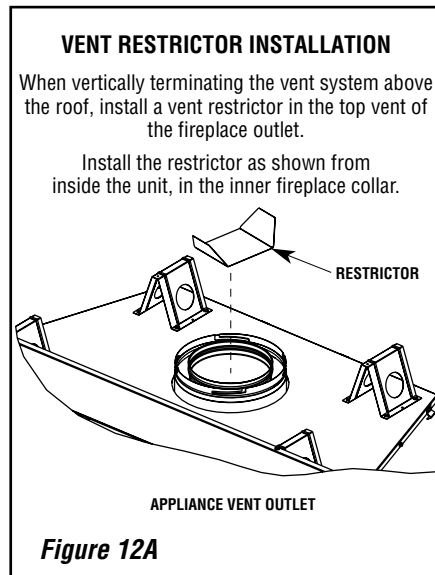

For vertical venting above 12 feet, in addition to the restrictor (**Figure 12A**) an air inlet baffle has to be installed over the grate as shown in **Figure 12B**.

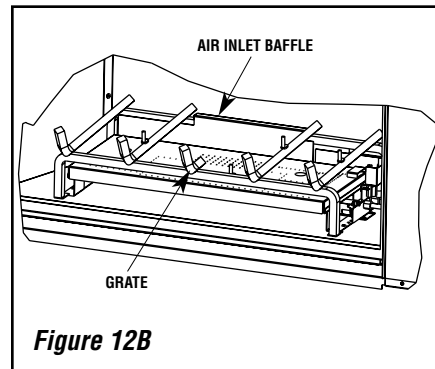

Vertical (Straight) Installation (Figure 13)

Determine the number of straight vent sections required. 4-1/2" (114 mm), 10-1/2" (267 mm), 22-1/2" (572 mm), 34-1/2" (876 mm) and 46-1/2" (1181 mm) net section lengths are available. Refer to the Vent Section Length Chart.

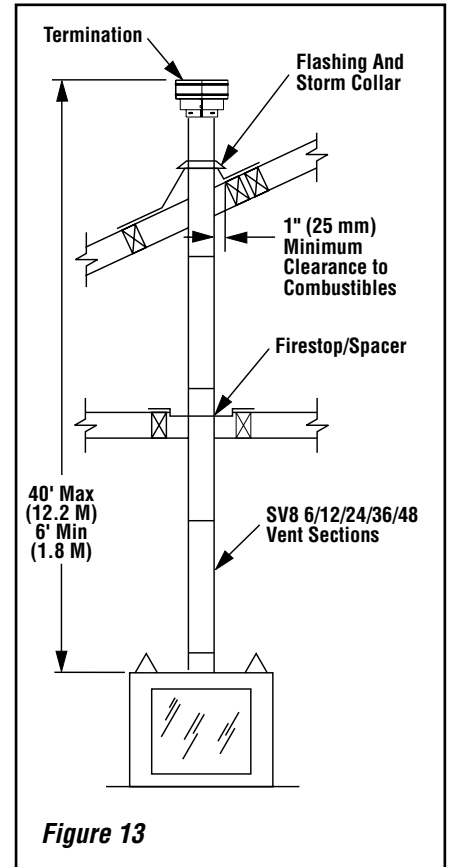

VENT SECTION LENGTH CHART							T O T A L
Nominal Section Length (inches)	6	12	24	36	48	Q U A N T I T Y	
Net Section Length (inches)	4-1/2	10-1/2	22-1/2	34-1/2	46-1/2		
Height of Vent	Number of Vent Sections					Q U A N T I T Y	
inches	ft						
4.5	0.375	1	0	0	0	0	1
9	0.75	2	0	0	0	0	2
10.5	0.875	0	1	0	0	0	1
15	1.25	1	1	0	0	0	2
19.5	1.625	2	1	0	0	0	3
21	1.75	0	2	0	0	0	2
22.5	1.875	0	0	1	0	0	1
25.5	2.125	1	2	0	0	0	3
31.5	2.625	0	3	0	0	0	3
34.5	2.875	0	0	0	1	0	1
37.5	3.125	1	1	1	0	0	3
43.5	3.625	0	2	1	0	0	3
45	3.75	0	0	2	0	0	2
46.5	3.875	0	0	0	0	1	1
49.5	4.125	1	0	2	0	0	3
51	4.25	1	0	0	0	1	2
55.5	4.625	0	1	2	0	0	3
57	4.75	0	0	1	1	0	2
66	5.25	0	2	2	0	0	4
67.5	5.625	0	0	3	0	0	3
69	5.75	0	0	0	2	0	2
72	6	1	0	3	0	0	4
73.5	6.125	1	0	0	2	0	3
79.5	6.625	0	1	0	2	0	3
81	6.75	0	0	0	1	1	2
90	7.5	0	2	1	0	1	4
91.5	7.625	0	0	2	0	1	3
93	7.75	0	0	0	0	2	2
96	8	1	0	1	2	0	4
97.5	8.125	1	0	0	0	2	3
102	8.5	2	0	0	0	2	4
103.5	8.625	0	0	0	3	0	3
108	9	1	0	0	3	0	4
114	9.5	0	2	0	0	2	4
117	9.75	1	0	5	0	0	6
118.5	9.875	1	1	0	3	0	5
126	10.5	0	0	1	3	0	4
130.5	10.875	1	0	1	3	0	5
135	11.25	0	0	6	0	0	6
138	11.5	0	0	0	4	0	4
139.5	11.625	0	0	0	0	3	3
142.5	11.875	1	0	0	4	0	5

VENT SECTION LENGTH CHART							T O T A L
Nominal Section Length (inches)	6	12	24	36	48	Q U A N T I T Y	
Net Section Length (inches)	4-1/2	10-1/2	22-1/2	34-1/2	46-1/2		
Height of Vent	Number of Vent Sections					Q U A N T I T Y	
inches	ft						
144	12	1	0	0	0	3	4
150	12.5	0	1	0	0	3	4
154.5	12.875	1	1	0	0	3	5
160.5	13.375	0	2	0	0	3	5
172.5	14.375	0	0	0	5	0	5
177	14.75	1	0	0	5	0	6
183	15.25	0	1	0	5	0	6
186	15.5	0	0	0	0	4	4
190.5	15.875	1	0	0	0	4	5
196.5	16.375	0	1	0	0	4	5
205.5	17.125	0	1	1	5	0	7
207	17.25	0	0	0	6	0	6
211.5	17.625	1	0	0	6	0	7
217.5	18.125	0	1	0	6	0	7
229.5	19.125	0	0	1	6	0	7
232.5	19.375	0	0	0	0	5	5
237	19.75	1	0	0	0	5	6
241.5	20.125	0	0	0	7	0	7
246	20.5	1	0	0	7	0	8
252	21	0	1	0	7	0	8
264	22	0	0	1	7	0	8
276	23	0	0	0	8	0	8
279	23.25	0	0	0	0	6	6
280.5	23.375	1	0	0	8	0	9
283.5	23.625	1	0	0	0	6	7
289.5	24.125	0	1	0	0	6	7
301.5	25.125	0	0	1	0	6	7
310.5	25.875	0	0	0	9	0	9
315	26.5	1	0	0	9	0	10
325.5	27.125	0	0	0	0	7	7
330	27.5	1	0	0	0	7	8
336	28	0	1	0	0	7	8
345	28.75	0	0	0	10	0	10
349.5	29.125	1	0	0	10	0	11
372	31	0	0	0	0	8	8
376.5	31.375	1	0	0	0	8	9
379.5	31.625	0	0	0	11	0	11
418.5	34.875	0	0	0	0	9	9
423	35.25	1	0	0	0	9	10
465	38.75	0	0	0	0	10	10

Vertical (Offset) Installation

Analyze the vent routing and determine the quantities of vent sections and number of elbows required. Refer to **Vertical Vent Figures and Tables on Pages 13 and 14** to select the type of vertical installation desired. Vent sections are available in net lengths of 4-1/2" (114 mm), 10-1/2" (267 mm), 22-1/2" (572 mm), 34-1/2" (876 mm) and 46-1/2" (1181 mm). Refer to the **Vent Section Length Chart on this Page** for an aid in selecting length combinations. Elbows are available in 90° and 45° configurations. Refer to **Figure 17 on Page 12** for the SV8 E45 and SV8 E90 elbow dimensional specifications.

Where required, a **telescopic vent section (SV8LA)** may be used to provide the installer with an option in installing in tight and confined spaces or where the vent run made up of fixed length pieces develops a joint in a undesirable location, or will not build up to the required length. The SV8LA Telescopic Vent Section has an effective length of from 1-1/2" (38 mm) to 6-3/4" (171 mm). The SV8LA is fitted with a dimpled end (identical to a normal vent section component) and a plain end with 3 pilot holes. Slip the dimpled end over the locking channel end of a standard SV8 vent component the required distance and secure with three screws.

Maintain a minimum 1" (25 mm) clearance to combustible materials for all vertical elements. Clearances for all horizontal elements are 3" (76 mm) on top, 1" (25 mm) on sides and 1" (25 mm) on the bottom.

A. Frame ceiling opening - Use a plumb line from the ceiling above the appliance to locate center of the vertical run. Cut and/or frame an opening, 13" x 13" (330 mm x 330 mm) inside dimensions, about this center mark (**Figure 14**).

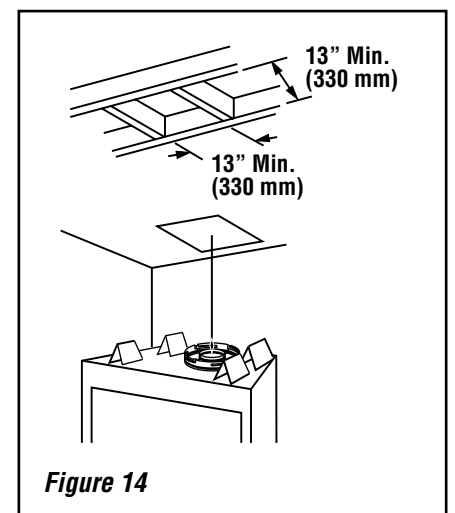

Figure 14

B. Attach vent components to appliance
- Secure Vent SV8 direct vent system components are unitized concentric pipe components featuring positive twist lock connections (see **Figure 15**).

All of the appliances covered in this document are fitted with collars having locking inclined channels. The dimpled end of the vent components fit over the appliance collar to create the positive twist lock connection.

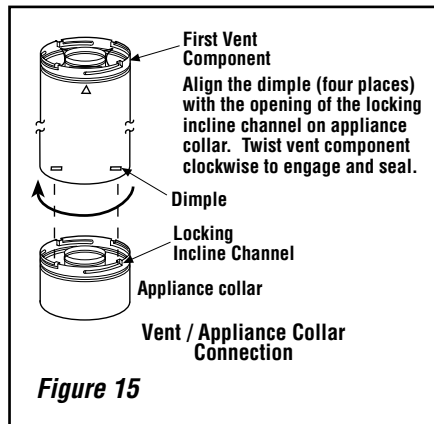

Figure 15

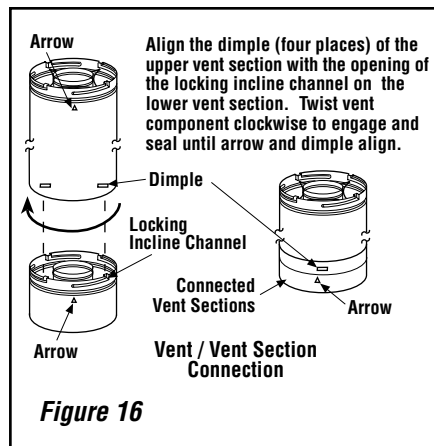

Figure 16

To attach a vent component to the appliance collar, align the dimpled end over the collar, adjusting the radial alignment until the four locking dimples are aligned with the inlet of the four inclined channels on the collar (refer to **Figure 15**). Push the vent component against the collar until it fully engages, then twist the component clockwise, running the dimples down and along the incline channels until they seat at the end of the channels. The unitized design of the **Secure Vent** components will engage and seal both the inner and outer pipe without the need for sealant or screws. If desired a #6 x 1/2" screw may be used at the joint, but it is not required as the pipe will securely lock when twisted.

C. Attach vent components to each other
 - Other vent sections may be added to the previously installed section in accordance with the requirements of the vertical vent figures and tables. To add another vent component to a length of vent run, align the dimpled end over the inclined channel end of the previously installed section, adjusting the radial alignment until the four locking dimples are aligned with the inlets of the four incline channels of the previous section.

Push the vent component against the previous section until it fully engages, then twist the component clockwise running the dimples down and along the incline channels until they seat at the end of the channels. **This seating position is indicated by the alignment of the arrow and dimple as shown in Figure 16.**

D. Install firestop/spacer at ceiling - When using Secure Vent, use SV8BF firestop/spacer at ceiling joists. If there is living space above the ceiling level, the firestop/spacer must be installed on the bottom side of the ceiling. If attic space is above the ceiling, the firestop/spacer must be installed on the top side of the joist. Route the vent sections through the framed opening and secure the firestop/spacer with 8d nails or other appropriate fasteners at each corner. **Remember to maintain 1" (25 mm) clearance to combustibles, framing members, and attic or ceiling insulation when running vertical chimney sections. Attic insulation shield (H3908) may be used to obtain the required clearances indicated here. See installation accessories on Pages 24 and 25. The gap between the vent pipe and a vertical firestop can be sealed with non-combustible caulking.**

E. Support the vertical vent run sections -

Note - Proper venting support is very important. The weight of the vent must not be supported by the fireplace in any degree.

Support the vertical portion of the venting system every 8 feet (2.4 m) above the fireplace vent outlet. One method of support is by utilizing field provided support straps (conventional plumber's tape). Secure the plumber's tape to the framing members with nails or screws. Strap the tape around the vent, securing the ends of the tape to the framing. If desired, sheet metal screws #6 x 1/2" length may be used to secure the support straps to the vent pipe.

F. Change vent direction to horizontal/inclined run - At transition from or to a horizontal/inclined run, install the SV8 E45 and SV8 E90 elbows in the same manner as the straight vent sections. The elbows feature a twist section to allow them to be routed about the center axis of their initial collar section to align with the required direction of the next vent run element. **Twist elbow sections in a clockwise direction only so as to avoid the possibility of unlocking any of the previously connected vent sections.** See **Figure 17**.

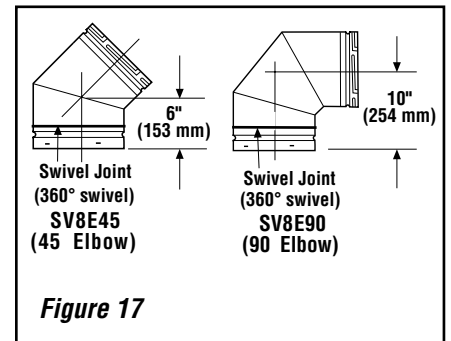
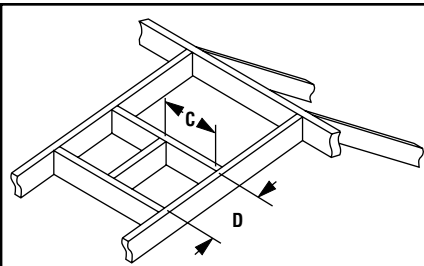

Figure 17

G. Continue installation of horizontal/inclined sections - Continue with the installation of the straight vent sections in horizontal/inclined run as described in **Step C**. Install support straps every 3' (914 mm) along horizontal/inclined vent runs using conventional plumber's tape. **It is very important that the horizontal/inclined run be maintained in a straight (no dips) and recommend to be in a slightly elevated plane, in a direction away from the fireplace 1/4" per foot (20 mm per meter) which is ideal, through rise per foot run ratios that are smaller are acceptable all the way down to at or near level. Use a carpenter's level to measure from a constant surface and adjust the support straps as necessary.**

It is important to maintain the required clearances to combustibles: 1" (25 mm) at all sides for all vertical runs; and 3" (76 mm) at the top, 1" (25 mm) at sides, and 1" (25 mm) at the bottom for all horizontal/inclined runs.

H. Frame roof opening - Identify location for vent at the roof. Cut and/or frame opening per Roof Framing Chart and **Figure 18 on Page 13**.



Framing Dimensions for Roof Inches (millimeters)		
Pitch	C	D
0/12	13 in. (330 mm)	13 in. (330 mm)
6/12	13 in. (330 mm)	15-1/2 in. (394 mm)
12/12	13 in. (330 mm)	20-1/2 in. (541 mm)

Figure 18 - Roof Framing

I. Install the roof flashing - Extend the vent sections through the roof structure. Install the roof flashing over the vent section and position such that the vent column rises vertically (use carpenter's level) (**Figure 19**). Nail along perimeter to secure flashing or adjust roofing to overlap the flashing edges at top and sides only and trim where necessary. Seal the top and both sides of the flashing with waterproof caulking.

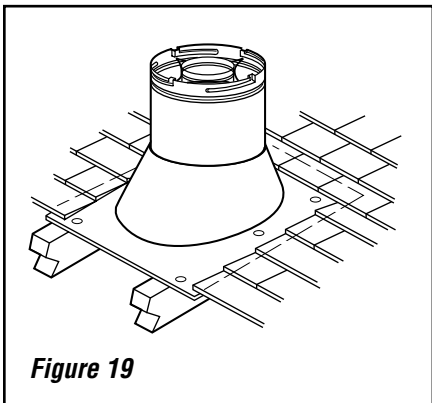

Figure 19

J. Install the storm collar - Install the storm collar, supplied with the flashing, over the vent/flashing joint. See **Figure 20**. Loosen the storm collar screw. Slide collar down until it meets the top of the flashing. Tighten the adjusting screw. Apply non-combustible caulking or mastic around the circumference of the joint to provide a water tight seal.

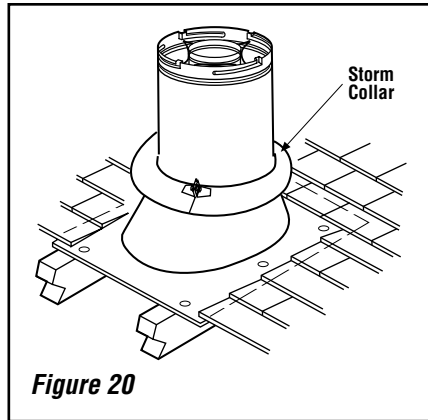

Figure 20

K. Install the vertical termination - The final step involves installation of the Vertical Termination. Extend the vent sections to the height as shown in the "Vertical vent termination section" on **Page 6**. The Vertical Termination (**Figure 21**) installs in the exact same fashion as any other **Secure Vent** section. Align the termination over the end of the previously installed section, adjusting the radial alignment until the four locking dimples of the termination are aligned with the inlets of the four incline channels of the last vent section. Push the termination down until it fully engages, then twist the termination clockwise running the dimples down and along the incline channels until they seat at the end of the channels.

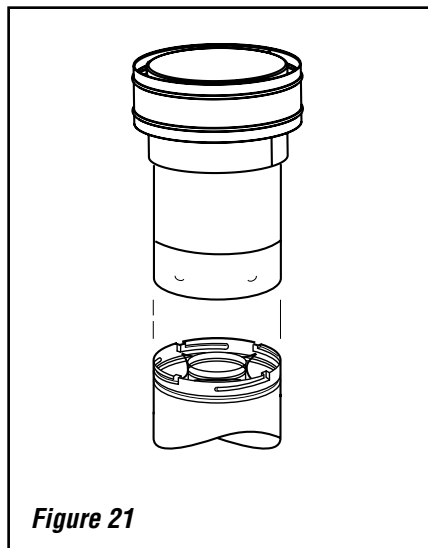

Figure 21

If the vent system extends more than 5' (1.5 m) above the roof flashing, stabilizers may be necessary. Additional screws may be used at section joints for added stability. Guide wires may be attached to the joint for additional support on multiple joint configurations.

VERTICAL VENT FIGURES/TABLES

Note: It is very important that the horizontal/inclined run be maintained in a straight (no dips) and recommended to be in a slightly elevated plane, in a direction away from the fireplace of 1/8" rise per foot (20 mm per meter) which is ideal, though rise per foot run ratios that are smaller are acceptable all the way down to at or near level.

Note: SV8BF (Secure Vent) firestop/spacer must be used anytime vent pipe passes through a combustible floor or ceiling. SV8HF (Secure Vent) firestop/spacer must be used anytime vent pipe passes through a combustible wall.

Note: Two 45 degree elbows may be used in place of one 90 degree elbow. The same rise to run ratios, as shown in the venting figures for 90 elbows, must be followed if 45 degree elbows are used.

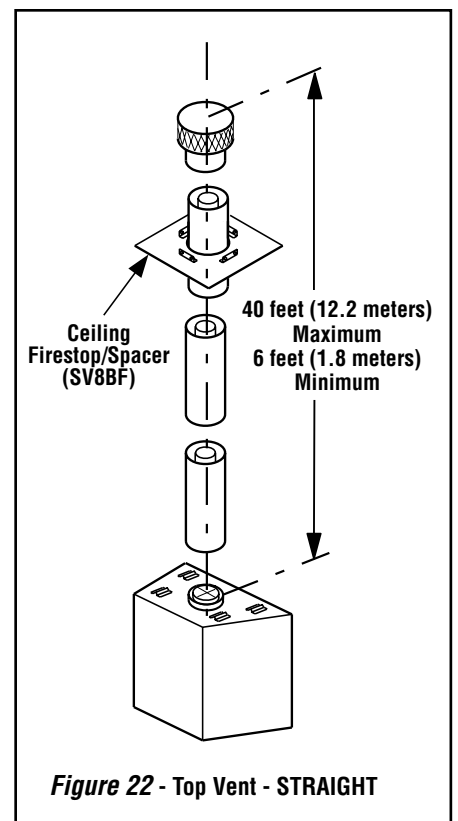

Figure 22 - Top Vent - STRAIGHT

VERTICAL VENT FIGURES/TABLES (continued)

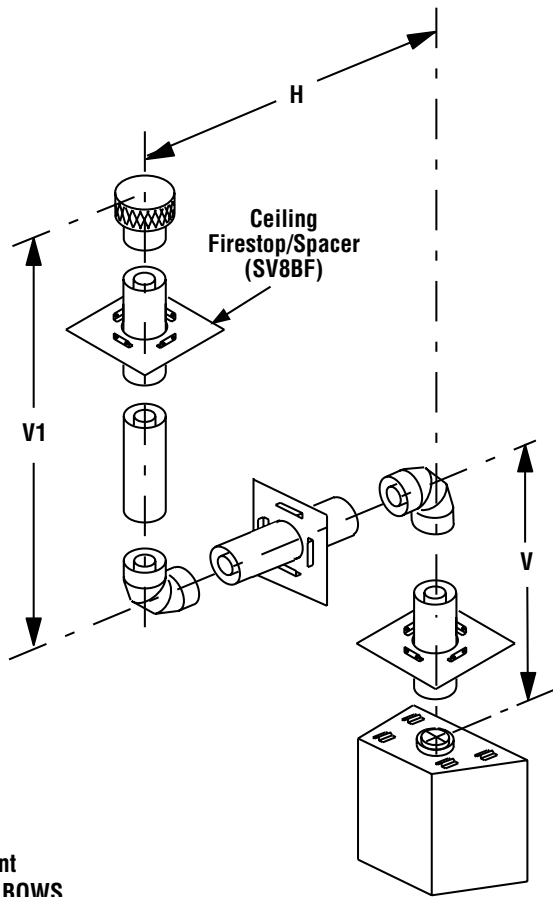

Table A			
H Maximum		V Minimum	
feet	(meter)	feet	(meter)
10	(3.1)	2.5	(0.762)
15	(4.65)	3.5	(1.07)
20	(6.2)	4.5	(1.37)

$V + V_1 + H = 40$ feet (12.4 meters) Max.
 $V + V_1 = 11$ feet (3.3 meters) Minimum for LSM40-2
 $V + V_1 = 10.5$ feet (3.2 meters) Minimum for LSM45-2

Figure 23 - Top Vent
TWO 90 DEGREE ELBOWS

Table B			
H + H ₁ Maximum		V Minimum	
feet	(meter)	feet	(meter)
10	(3.1)	2.5	(0.762)
15	(4.65)	3.5	(1.06)
20	(6.2)	4.5	(1.37)

$H + H_1 = 20$ feet (6.2 m) Max.
 $V + V_1 + H + H_1 = 40$ ft. (12.4 m) Max.
 $V + V_1 = 11$ feet (3.3 meters) Min. for LSM40-2
 $V + V_1 = 10.5$ feet (3.2 meters) Min. for LSM45-2

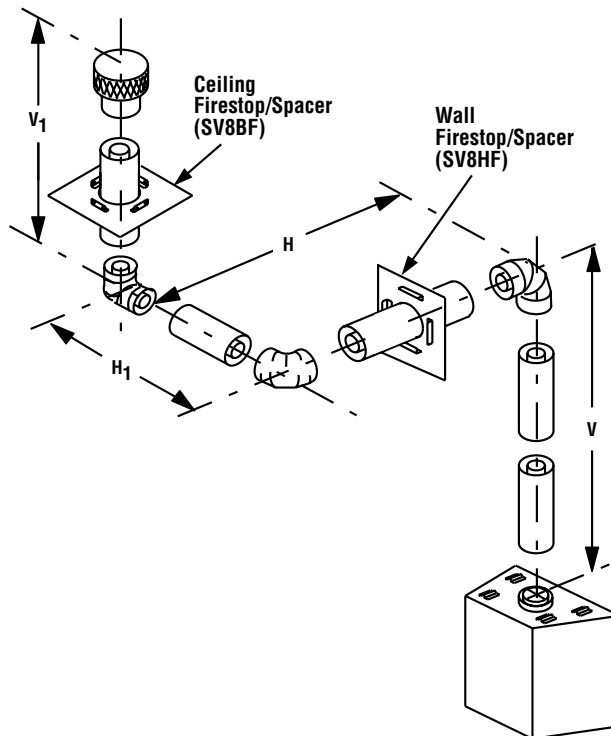

Figure 24 - Top Vent - THREE ELBOWS

HORIZONTAL (OUTSIDE WALL) TERMINATION SYSTEM

Figures 25, 28, 29 and 30 on Pages 15, 17 and 18 and their associated Horizontal Vent Table illustrate the various horizontal venting configurations that are possible for use with these appliances. A Horizontal Vent Table summarizes each system's minimum and maximum vertical and horizontal length values that can be used to design and install the vent components in a variety of applications.

The horizontal vent system terminates through an outside wall. Building Codes limit or prohibit terminating in specific areas. Refer to **Figure 8 on Page 7** for location guidelines.

Secure Vent SV8 direct vent system components are unitized concentric pipe components featuring positive twist lock connection, (refer to **Figure 16 on Page 12**). All of the appliances covered in this document are fitted with collars having locking inclined channels. The dimpled end of the vent components fit over the appliance collar to create the positive twist lock connection.

A. Plan the vent run -

Analyze the vent routing and determine the types and quantities of sections required 4-1/2" (114 mm), 10-1/2" (267 mm), 22-1/2" (572 mm), 34-1/2" (876 mm) and 46-1/2" (1181 mm) net section lengths are available. Make allowances for elbows as indicated in **Figure 17 on Page 12**.

Maintain a minimum 1" (25 mm) clearance to combustibles on the vertical sections. Clearances for the horizontal runs are; 3" (76 mm) on top, 1" (25 mm) on sides, and 1" (25 mm) at the bottom.

B. Frame exterior wall opening -

Locate the center of the vent outlet on the exterior wall according to the dimensions shown in **Figure 9 on Page 8**.

Cut and/or frame an opening, 15" x 13" (381 mm x 330 mm) inside dimensions, with 9" above center and 7" below center.

C. Frame ceiling opening - If the vertical route is to penetrate a ceiling, use plumb line to locate the center above the appliance. Cut and/or frame an opening, 13" x 13" (330 mm x 330 mm) inside dimensions, about this center (refer to **Figure 14 on Page 11**).

D. Attach vent components to appliance - To attach a vent component to the appliance collar, align the dimpled end over the collar, adjusting the radial alignment until the four locking dimples are aligned with the inlets of the four incline channels on the collar (refer to **Figure 15 on Page 12**).

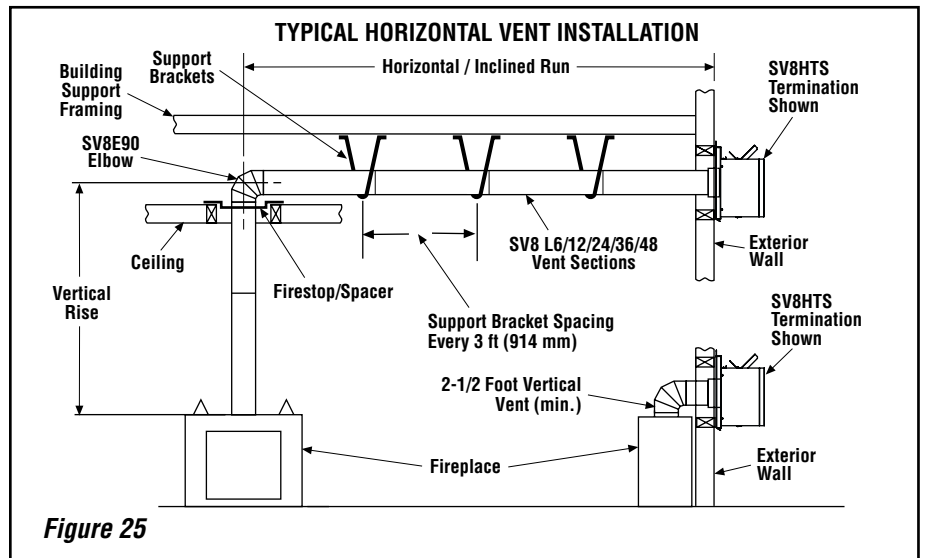

Push the vent component against the collar until it fully engages, then twist the component clockwise, running the dimples down and along the incline channels until they seat at the end of the channels. The unitized design of the **Secure Vent** components will engage and seal both the inner and outer pipe elements with the same procedure. Sealant and securing screws are not required.

E. Attach vent components to each other

- Other vent sections may be added to the previously installed section in accordance with the requirements of the vent tables. To add another vent component to a length of vent run, align the dimpled end of the component over the inclined channel end of the previously installed section, adjusting the radial alignment until the four locking dimples are aligned with the inlets of the four incline channels of the previous section. Push the vent component against the previous section until it fully engages, then twist the component clockwise running the dimples down and along the incline channels until they seat at the end of the channels. **This seating position is indicated by the alignment of the arrow and dimple as shown in Figure 16 on Page 12.**

F. Install firestop/spacer at ceiling -

When using **Secure Vent**, use SV8BF firestop/spacer at ceiling joists. If there is living space above the ceiling level, the firestop/spacer must be installed on the bottom side of the ceiling. If attic space is above the ceiling, the firestop/spacer must be installed on the top side of the joist. Route the vent sections through the framed opening and secure the firestop/spacer with 8d nails or other appropriate fasteners at each corner.

Remember to maintain 1" (25 mm) clearance to combustibles, framing members, and attic or ceiling insulation when running vertical chimney sections.

G. Support the vertical run sections -

On the vertical run, support the venting system every 8 feet (2.4m) above the fireplace vent outlet with field provided support straps (Plumber's tape). Attach the straps to the vent pipe and secure to the framing members with nails or screws.

H. Change vent direction - At transition from or to a horizontal/inclined run, install the SV8E45 and SV8E90 elbows in the same manner as the straight vent sections. The elbows feature a twist section to allow them to be routed about the center axis of their initial collar section to align with the required direction of the next vent run element. **Twist elbow sections in a clockwise direction only so as to avoid the possibility of unlocking any of the previously connected vent sections (see Figure 17 on Page 12).**

I. Continue installation of horizontal/inclined sections - Continue with the installation of the straight vent sections in horizontal/inclined run as described in **Step E**. Install support straps every 3 feet (914 mm) along horizontal/inclined vent runs using conventional plumber's tape. See **Figure 25**, it is very important that the horizontal/inclined run be maintained in a straight (no dips) and recommended to be in a slightly elevated plane, in a direction away from the fireplace of 1/4" rise per foot (20 mm per meter) which is ideal, though rise per foot run ratios that are smaller are acceptable all the way down to at or near level. Use a carpenter's level to measure from a constant surface and adjust the support straps as necessary.

It is important to maintain the required clearances to combustibles: 1" (25 mm) at all sides for all vertical runs; and 3" (76 mm) at the top, 1" (25 mm) at sides, and 1" (25 mm) at the bottom for all horizontal/inclined runs

J. Assemble vent run to exterior wall - If not previously measured, locate the center of the vent at the exterior wall. Prepare an opening as described in **Step B**. Assemble the vent system to point where the terminus of the last section is within 5 in. (127 mm) to 8-1/2 in. (216 mm) inboard of the exterior surface to which the SV8HTS termination is to be attached, see **Figure 27**. If the terminus of the last section is not within this distance, use the **telescopic vent section SV8LA**, as the last vent section. For wall thicknesses greater than that shown in **Figure 27**, refer to **Table 6 on Page 17**. This table lists the additional venting components needed (in addition to the termination and adapter) for a particular range of wall thicknesses.

K. Attach termination adapter - Attach the adapter (adapter - SV8RCH - provided with the termination) to the vent section or telescoping vent section), or elbow as shown in **Figure 26** in the same manner as any SV vent component (refer to **Step E**).

L. Install Firestop/Spacer at exterior wall - When using the square termination, install SV8HF Firestop/Spacer over the opening at the exterior side of the framing, long side up, with the 3 inch spacer clearance at the top as shown in **Figure 26**, and nail into place.

(The Firestop/Spacer may also be installed over the opening at the interior side of the framing).

M. Install the square termination (SV8HTS)- For the last step, from outside the exterior wall, slide the collars of the termination onto the adapter (the outer over the outer and the inner inside the inner) until the termination seats against the exterior wall surface to which it will be attached. Orient the housing of the termination with the arrow pointed upwards. Secure the termination to the exterior wall. **The horizontal termination must not be recessed into the exterior wall or siding** by more than the 1-1/4" (32 mm) as shown in **Figure 27**.

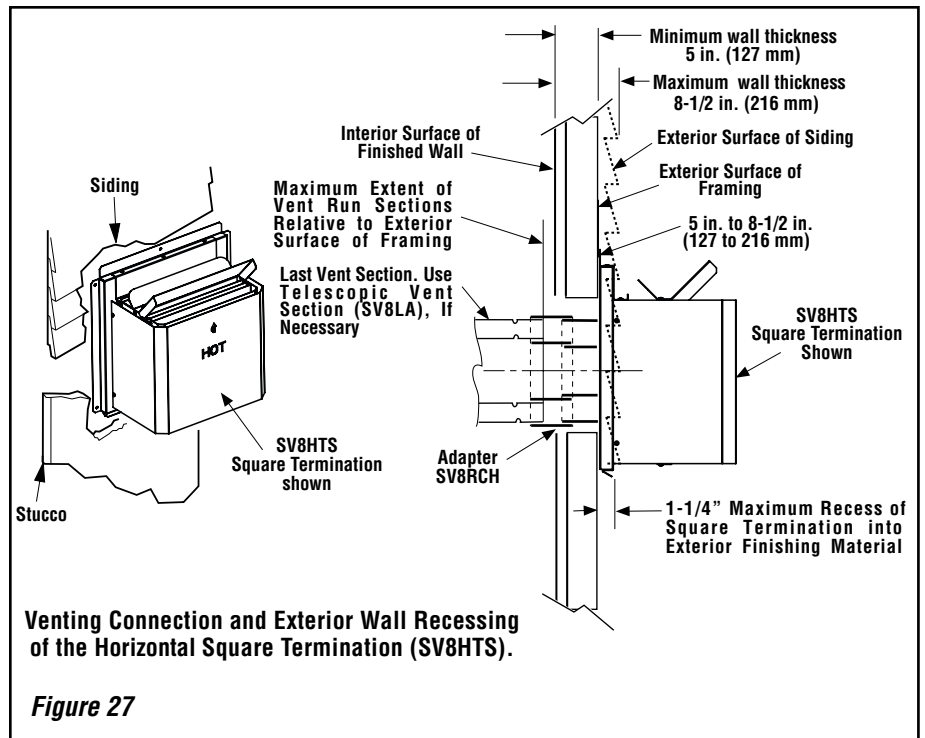
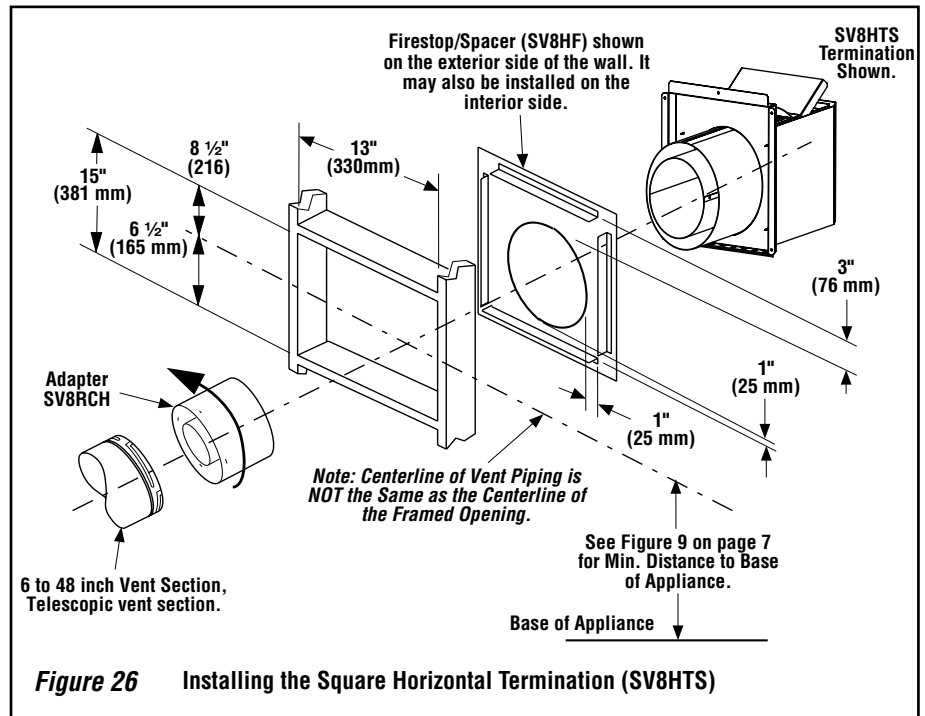

HORIZONTAL VENT FIGURES/TABLES

Note: Two 45 degree elbows may be used in place of one 90 degree elbow. The same rise to run ratios, as shown in the venting figures for 90 elbows, must be followed if 45 degree elbows are used.

Note: It is very important that the horizontal/inclined run be maintained in a straight (no dips) and recommended to be in a slightly elevated plane, in a direction away from the fireplace of 1/4" rise per foot (20 mm per meter) which is ideal, though rise per foot run ratios that are smaller are acceptable all the way down to at or near level.

Note: SV8BF (Secure Vent) firestop/spacer must be used anytime vent pipe passes through a combustible floor or ceiling. SV8HF (Secure Vent) firestop/spacer must be used anytime vent pipe passes through a combustible wall.

Vent Components Required	Exterior Wall Thickness - inches (mm)
Termination Kit Only	5 to 8-1/2 (127 to 216)
Termination Kit and 6 In. Vent Section (SV8L6)	9-3/4 to 14 (248 to 356)
Termination Kit and Telescopic Section (SV8LA)	6-3/4 to 15-1/4 (171 to 387)
Termination Kit and Telescopic Section (SV8LA) and 6 in. vent section (SV8L6)	11-1/4 to 19-3/4 (286 to 502)

Table 6

H Maximum		V Minimum	
feet	(meter)	feet	(meter)
3.5	(1.07)	2.5	(0.762)
6.5	(1.98)	3.5	(1.07)
8.5	(2.6)	4.5	(1.37)
10.5	(3.2)	5.5	(1.68)
12.5	(3.8)	6.5	(1.98)
14.5	(4.4)	7.5	(2.3)
16.5	(5.0)	8.5	(2.6)
18.5	(5.6)	9.5	(2.9)
20	(6.0)	10	(3.0)
V + H = 40 feet (12.4 m) Max.			
H = 20 ft. (6.2 m) Max.			

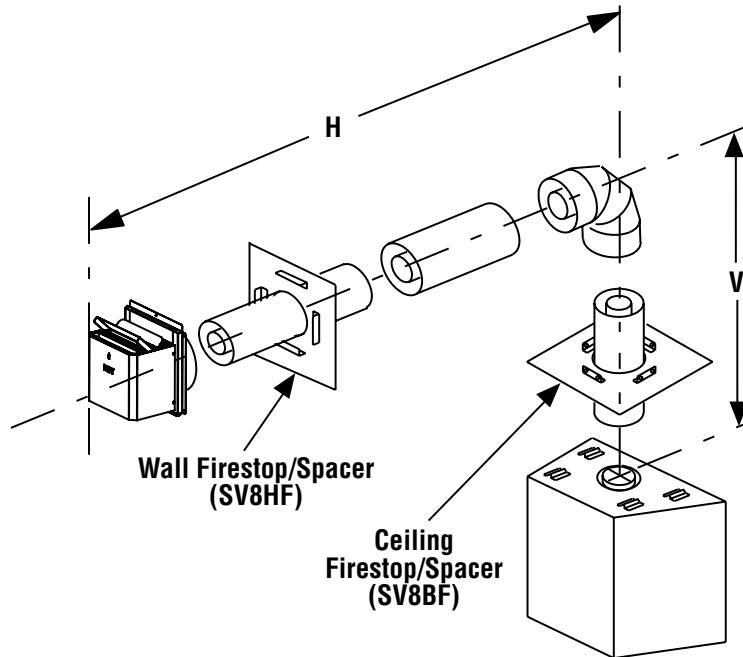

Square termination (SV8HTS) shown.

See **Table 6** as an aid in venting component selection for a particular range of exterior wall thicknesses.

Figure 28 - Top Vent - ONE 90 DEGREE ELBOW - ELBOW CONNECTION NOT DIRECTLY AT APPLIANCE

HORIZONTAL VENT FIGURES/TABLES
(continued)

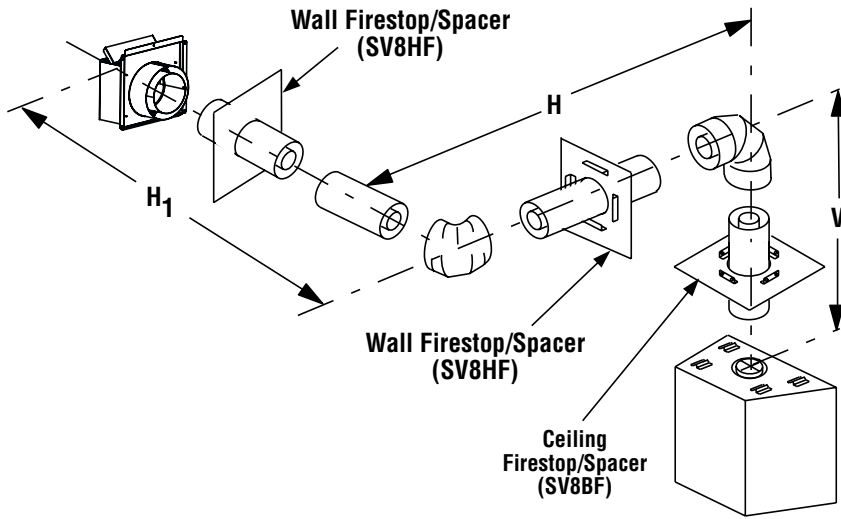

H + H ₁ Maximum		V Minimum	
feet	(meter)	feet	(meter)
3.5	(1.07)	2.5	(0.762)
6.5	(1.98)	3.5	(1.07)
8.5	(2.6)	4.5	(1.37)
10.5	(3.2)	5.5	(1.68)
12.5	(3.8)	6.5	(1.98)
14.5	(4.4)	7.5	(2.3)
16.5	(5.0)	8.5	(2.6)
18.5	(5.6)	9.5	(2.9)
20	(6.0)	10	(3.0)

V + H + H₁ = 40 feet (12.4 m) Max.
H + H₁ = 20 ft. (6.2 m) Max.

See **Table 6 on Page 17** as an aid in venting component selection for a particular range of exterior wall thicknesses.

Figure 29 - Top Vent - TWO 90 DEGREE ELBOWS

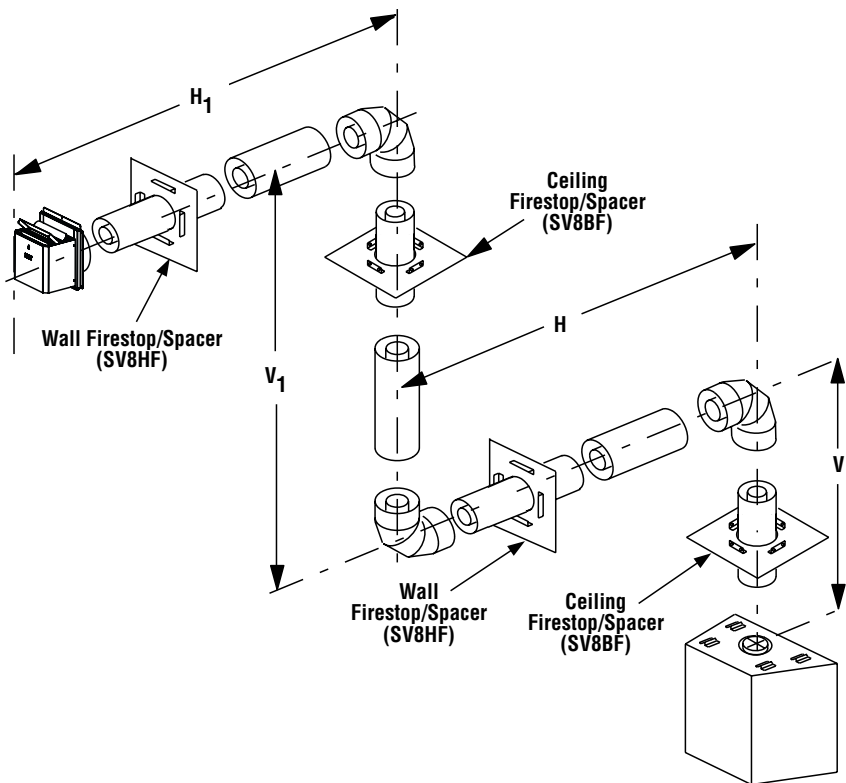

H + H ₁ = 20 feet (6.2 m) Max.
V + V ₁ + H + H ₁ = 40 ft. (12.4 m) Max.
V = 2.5 feet Min. (0.762 m)
V + V ₁ = 11 feet (3.35 m) Min. for LSM40-2
V + V ₁ = 10.5 feet (3.2 m) Min. for LSM45-2

See **Table 6 on Page 17** as an aid in venting component selection for a particular range of exterior wall thicknesses.

Figure 30 - Top Vent - THREE 90 DEGREE ELBOWS

Step 4. FIELD WIRING

Caution: Label all wires prior to disconnection when servicing controls. Wiring errors can cause improper and dangerous operation. Verify proper operation after servicing.

Refer to Section A for millivolt appliances and Section B for electronic appliances. The gas valve is set in place and pre-wired at the factory on both models.

A. Millivolt Wiring (See Figure 31) –

1. Appliance-mounted ON/OFF burner control switch (rocker switch) is factory installed. Optional wall-mounted switch, or one of the optional remote control kits may also be used.
2. If wall-mounted ON/OFF control is selected mount it in a convenient location on a wall near the fireplace.
3. Wire the control switch within the millivolt control circuit using the 15 feet of 2 conductor wire supplied with the unit.

Note: The supplied 15 feet of 2 conductor wire has one end of each conductor connected to the gas valve circuit and the other end of each conductor placed on top of the unit.

Caution: Do Not connect the optional wall switch to a 120V power supply.

4. If an optional control switch is installed, turn the appliance-mounted ON/OFF burner control switch to the OFF position.

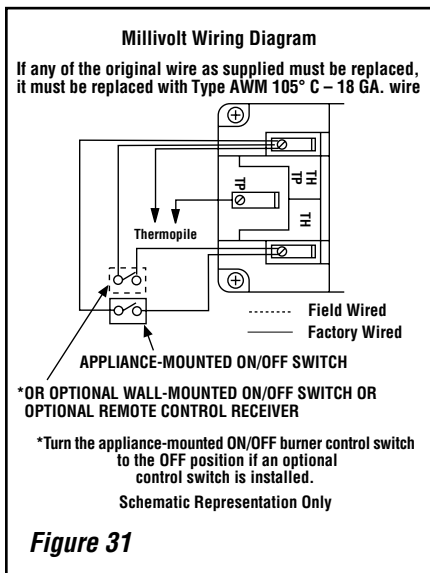

B. Electronic Wiring (See Figures 32A and 32B)

Note: The electronic appliance must be connected to the main power supply.

1. Route a 3-wire 120Vac 60Hz 1ph power supply to the appliance junction box.
2. Remove the electrical inlet cover plate from the side of the unit by removing the plate's securing screws. See Figure 11 on Page 9.

3. Remove the cover plate's knockout and then feed the power supply wire through the knockout opening and into the unit junction box.
4. Connect the black power supply wire to the power outlet's red pigtail lead and the white power supply wire to the common terminal of the outlet as shown in Figures 32A and 32B.
5. Connect the ground supply wire to the pigtail lead attached to outlet's green ground screw.
6. Appliance-mounted ON/OFF burner control switch (rocker switch) is factory installed. Optional wall-mounted switch, or one of the optional remote control kits may also be used.
7. If wall-mounted ON/OFF control is to be used, mount it in a convenient location on a wall near the fireplace.
8. If an optional control is to be used, wire it in the low voltage circuit (see Figures 32A and 32B).

Note: The supplied 15 feet of 2 conductor wire has one end of each conductor connected in parallel with the appliance mounted ON/OFF burner control switch and the other end of each conductor placed on top of the unit.

Caution: Do Not connect the optional wall switch to a 120V power supply.

9. If an optional control switch is installed, turn the appliance-mounted ON/OFF burner control switch to the OFF position.

10. After the wiring is complete, replace the cover plate.

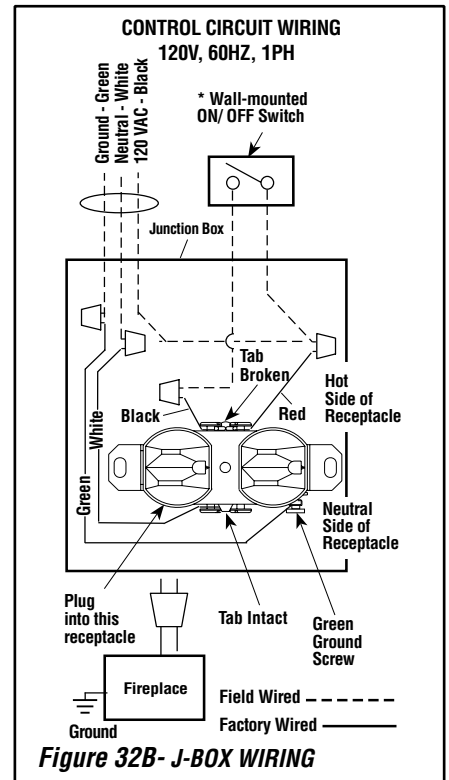

CAUTION

Ground supply lead must be connected to the wire attached to the green ground screw located on the outlet box. See Figures 32A and 32B. Failure to do so will result in a potential safety hazard. The appliance must be electrically grounded in accordance with local codes or, in the absence of local codes, the National Electrical Code, ANSI/NFPA 70-latest edition. (In Canada, the current CSA C22-1 Canadian Electrical Code).

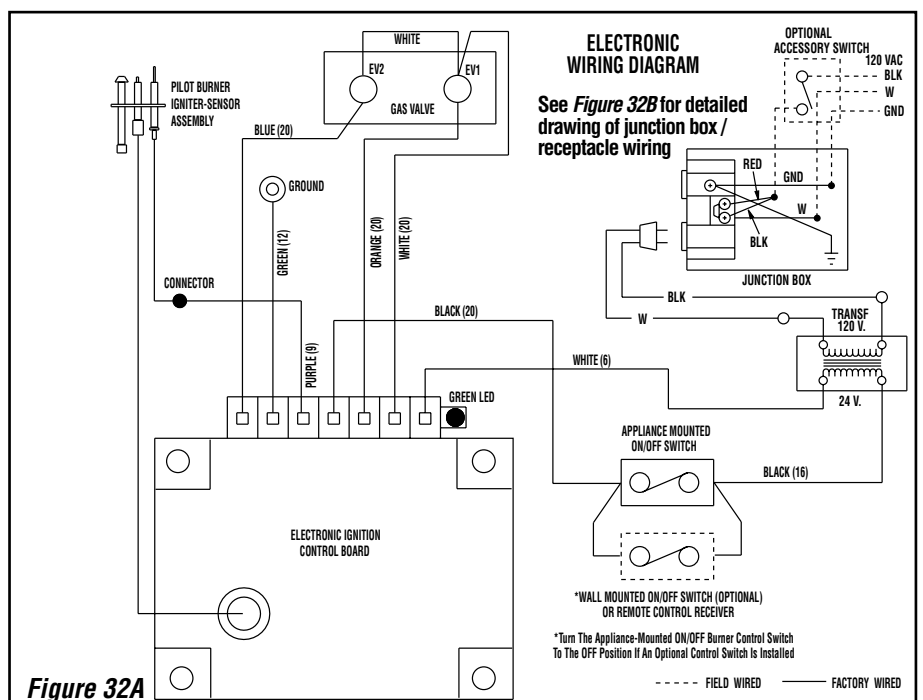

Step 5. REMOVING GLASS DOOR FRAME ASSEMBLY

! WARNING

Handle this glass with extreme care! Glass is susceptible to damage – Do not scratch or handle roughly while reinstalling the glass door frame.

! WARNING

Do not attempt to substitute the materials used on this door, or replace cracked or broken glass with any materials other than those provided by the appliance manufacturer.

! WARNING

The glass door of this appliance must only be replaced as a complete unit as provided by the manufacturer. Do not attempt to replace broken, cracked or chipped glass separately.

Refer to *Figure 37 on Page 21* and remove the front glass door assembly as follows:

To remove the firescreens, lift up the center of the rod to disengage it from the center bracket, bend down at center, hold left side with hand until it disengages from left side, being careful not to scratch paint. Slowly remove the rod from the right side.

Using a Phillips screwdriver, unfasten two (2) screws located at the top of the glass frame.

Tilt the glass frame at the top away from the unit. Lift it carefully off the bottom door track and set the door aside, protecting it from inadvertent damage.

Step 6. CONNECTING GAS LINE

Make gas line connections. Codes require a shut-off valve mounted in the supply line. *Figure 33* illustrates two methods for connecting the gas supply. The flex-line method is acceptable in the U.S., however, Canadian requirements vary depending on locality. Installation must be in compliance with local codes.

These appliances are equipped with a gas flex line for use (where permitted) in connecting the unit to the gas line. A gas flex line is provided to aid in attaching the direct vent appliance to the gas supply. The gas flex line can only be used where local codes permit. See *Figure 33* for flex line description. The flex line is rated for both natural and propane gas. A manual shut off valve is also provided with the flex line.

The gas control valve is located on the right side of the unit.

To access the valve, remove the front door assembly and the access plate (refer to *Figure 34*).

The control valves have a 3/8" (10 mm) NPT thread inlet port.

Secure all joints tightly using appropriate tools and sealing compounds (ensure propane resistant compounds are used in propane applications).

Test all connections for gas leaks (Factory and field):

! WARNING

Never use an open flame to check for leaks.

Turn on gas supply and test for gas leaks using a gas leak test solution (also referred to as bubble leak solution). **Note:** Using a soapy water solution (50% dish soap, 50% water) is an effective leak test solution but it is not recommended, because the soap residue that is left on the pipes/fittings can result in corrosion over time.

- Light the appliance (refer to the lighting instructions label in control compartment or homeowner's manual).
- Brush all joints and connections with the gas leak test solution to check for leaks. If bubbles are formed, or gas odor is detected, turn the gas control knob (off/pilot/on) to the "OFF" position. Either tighten or refasten the leaking connection, then retest as described above.
- When the gas lines are tested and leak free be sure to rinse off the leak testing solution,

- Turn on burner then observe the individual tongues of flame on the burner. Make sure all ports are open and producing flame evenly across the burner. If any ports are blocked, or partially blocked, clean out the ports.

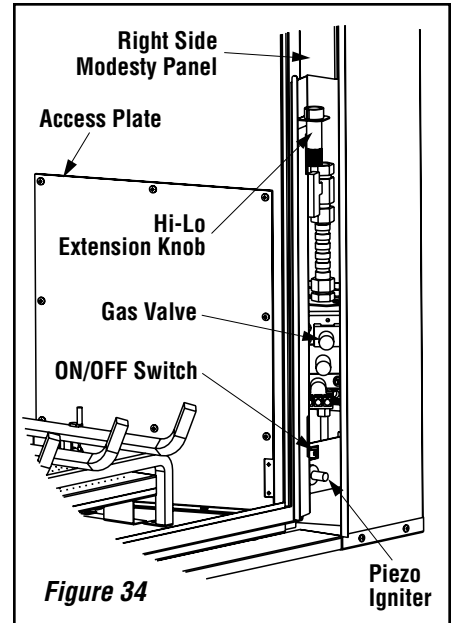

- Re-install the access plate, making certain the gasket has not been damaged.

Step 7. INSTALLING CERAMIC PANELS, LOGS AND GLOWING EMBERS

The logs are packaged in a carton and shipped separately. Plastic bags with glowing embers, lava rock and vermiculite are also included. Refer to the **Ceramic Panel and Log Set Placement Supplement** for detailed placement instructions.

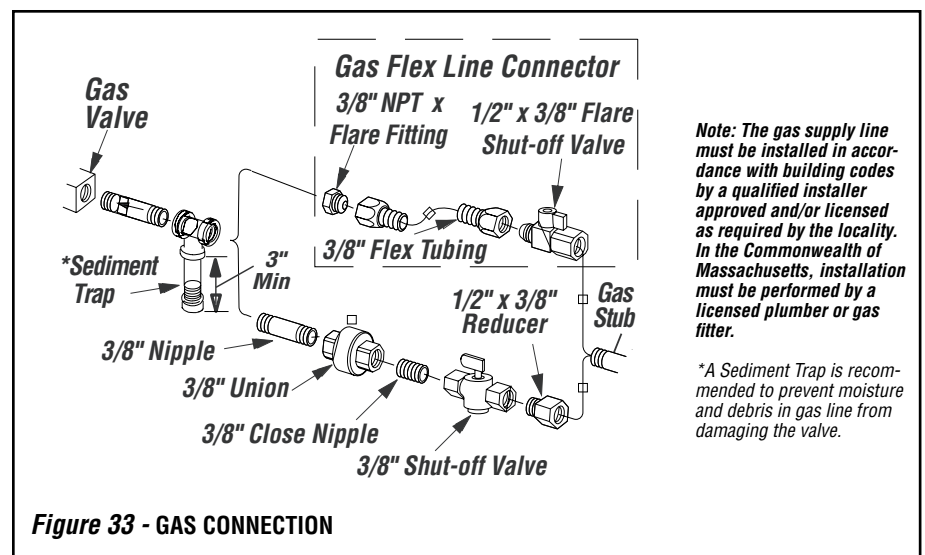

Note: The gas supply line must be installed in accordance with building codes by a qualified installer approved and/or licensed as required by the locality. In the Commonwealth of Massachusetts, installation must be performed by a licensed plumber or gas fitter.

*A Sediment Trap is recommended to prevent moisture and debris in gas line from damaging the valve.

Figure 33 - GAS CONNECTION

NOTE: DIAGRAMS & ILLUSTRATIONS ARE NOT TO SCALE.

Step 8. CHECKING APPLIANCE OPERATION

With gas line installed run initial system check-out before closing up the front of the unit. Follow the pilot lighting instructions provided. For piezo igniter location refer to **Figure 34** (millivolt appliances only).

Note: Lighting Instructions are also found on the literature tag tied to the bracket above the gas valve. To access the tag, reach into the right side opening.

When first lighting the appliance, it will take a few minutes for the line to purge itself of air. Once purging is complete, the pilot and burner will light and operate as indicated in the instruction manual. Subsequent lighting of the appliance will not require such purging. Inspect the pilot flame (remove logs, if necessary, handling carefully).

Millivolt Appliance Checkout

The pilot flame should be steady, not lifting or floating. Flame should be blue in color with traces of orange at the outer edge.

The top 3/8" (10 mm) at the pilot generator (thermopile) and the top 1/8" minimum (tip) of the quick drop out thermocouple should be engulfed in the pilot flame.

The flame should project 1" (25 mm) beyond the hood at all three ports (**see Figure 35**). Replace logs if removed for pilot inspection.

To light the burner; rotate the gas valve control knob counterclockwise to the "ON" position ("ON" will be at the bottom side of the valve) and turn "ON" the appliance mounted ON/OFF switch.

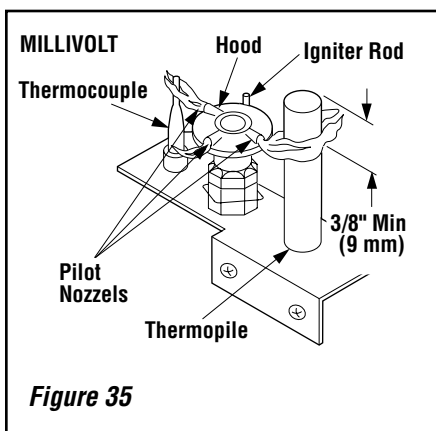

Figure 35

Electronic Appliance Checkout

To light the burner, turn "ON" the optional remote wall switch or turn the appliance mounted ON/OFF switch to the "ON" position. Ensure the igniter lights the pilot. The pilot flame should engulf the flame rod as shown in **Figure 36**.

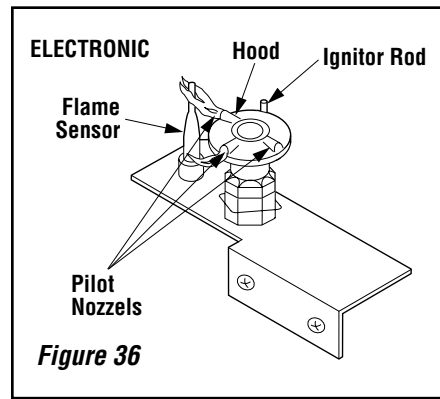

Figure 36

Step 9. INSTALLING THE GLASS DOOR

Retrieve the glass door. Visually inspect the gasket on the backside of the frame. Gasket surface must be clean, free of irregularities and seated firmly.

Position the door in front of the firebox opening with the top of the door held away from the fireplace (**Figure 37**). Lower the bottom of the door assembly on the bottom door track and set on padded surface. Pivot the door up after engaging and centering in the base channel.

Using a Phillips screwdriver, fasten the door frame to the door latch with the two (2) screws. The latch should pull forward to engage the door frame.

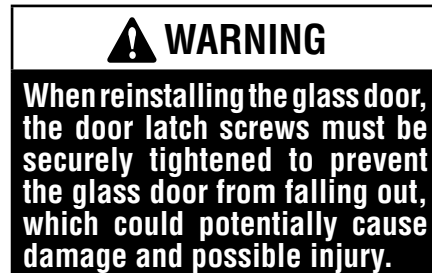

Install the door modesty shield on top flange glass door as follows: grab the door modesty shield with both hands, with the open hem going down and engage it with the upper lip of the glass door frame by pushing it all the way down. Make sure the installed shield is firmly in place.

With the firescreen hanging on the screen rod, insert the right side of the rod into the existing hole on the right modesty panel. Bend down the rod at the center and drop the left end into the slot on the left modesty panel, being careful not to scratch the paint.

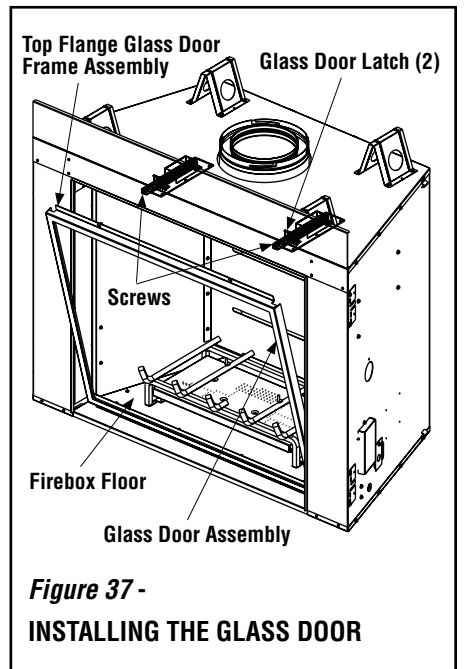

**Figure 37 -
INSTALLING THE GLASS DOOR**



Step 10. BURNER ADJUSTMENTS

Flame Appearance and sooting

Proper flame appearance is a matter of taste. Generally, most people prefer the warm glow of a yellow to orange flame. Appliances operated with air shutter openings that are too large will exhibit flames that are blue and transparent. These weak, blue and transparent flames are termed anemic.

If the air shutter opening is too small sooting may develop. Sooting is indicated by black puffs developing at the tips of very long orange flames.

Sooting results in black deposits forming on the logs, appliance inside surfaces and on exterior surfaces adjacent to the vent termination. Sooting is caused by incomplete combustion in the flames and lack of combustion air entering the air shutter opening. To achieve a warm yellow to orange flame with an orange body that does not soot, the shutter opening must be adjusted between these two extremes.

No smoke or soot should be present. Reposition the logs if flames impinge on any of them.

If the logs are properly positioned and sooting conditions exist, the air shutter opening on the main burner tube should be adjusted. Normally, the more offsets in the vent system, the greater the need for the air shutter to be opened further.

Burner Adjustment

! WARNING

Air shutter adjustment should only be performed by a qualified professional service technician.

To adjust the flame, rotate the air shutter toward the back or toward the front of the fireplace. Position the air shutter to the factory setting as shown in the table in **Figure 38**. Allow the burner to operate for at least 15 minutes. Observe the flame continuously. If it appears weak or sooty as previously described, adjust the air shutter until the flame appearance is as desired.

Use the extension knob (refer to **Figure 34**), to adjust the flame height as desired, by sliding the knob over the variable flame adjustment knob located on the front of the valve. Replace the extension knob back to the hanger after the adjustment.

Propane models may exhibit a flame pattern that may candle or appear stringy. If this is problematic or persists as the appliance is continually operated, adjust the air shutter closed as described in the previous paragraphs. Operate the appliance for a period of time as the effect diminishes, ensuring that the appliance does not develop sooty flames. When satisfied that the appliance operates properly, proceed to finish the installation.

Leave the control knob in the ON position and the remote switch OFF.

Main Burner Factory Air Shutter Opening Setting - Inches (millimeter)		
Model	Nat. Gas	Propane Gas
LSM40-2	1/16 (1.59)	9/32 (7.14)
LSM45-2	1/16 (1.59)	9/32 (7.14)

Figure 38

NOTE: DIAGRAMS & ILLUSTRATIONS ARE NOT TO SCALE.

FINISHING REQUIREMENTS

Wall Details

Complete finished interior wall. To install the appliance facing flush with the finished wall, position framework to accommodate the thickness of the finished wall (**Figure 39**).

① Installations with horizontal terminations which have minimum vertical vent height only will require 4" (102mm) minimum side clearance as shown in shaded zone above. All other installations require 1" (25mm) minimum side clearance as specified in **Table 4** on **Page 5**.

* Insulation is NOT ALLOWED in the clearance zones around vent components. Keep this area free from combustible materials.

Figure 39

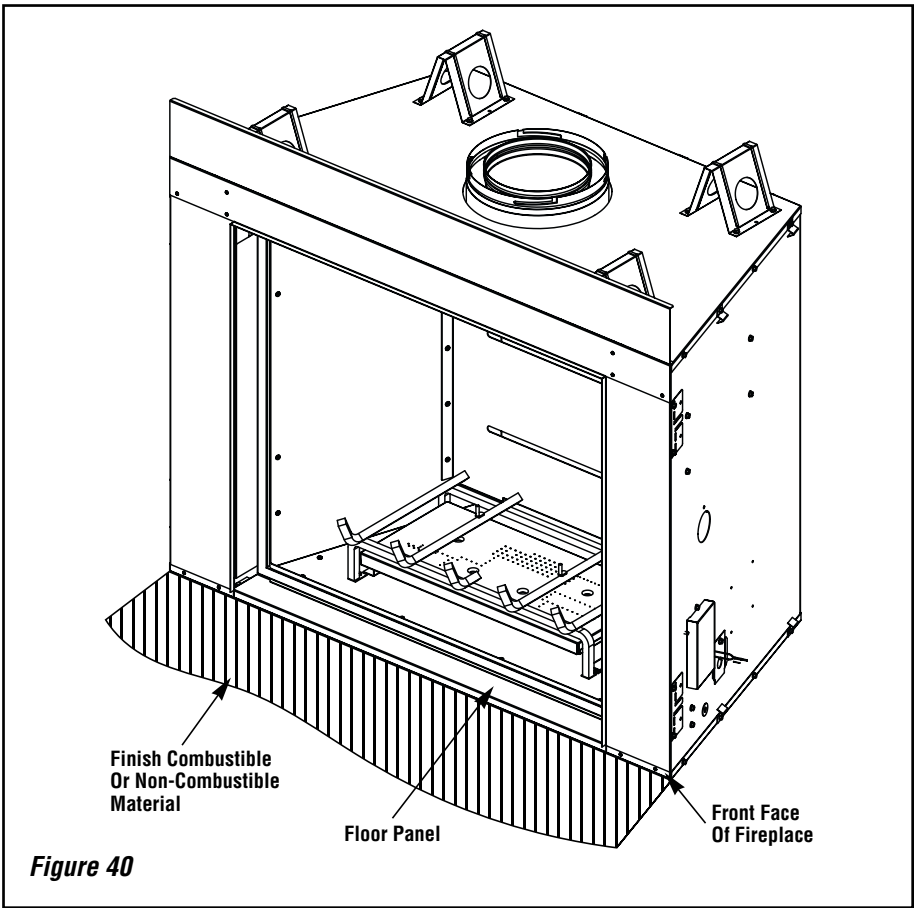

A hearth extension is not required with this appliance. If a hearth extension is used, there are two methods of installation. One, the finish combustible or non-combustible material could be ended by butting up against the front face of the fireplace and the floor panel (refer to **Figure 40**).

Two, the finish combustible or non-combustible material could be ended below the fireplace (refer to **Figure 41**). Remove the floor panel as shown in **Figure 40** by removing the screws on the right side of the panel and sliding the left side away from the tab. Discard the screws and floor panel. **It is critical that there is at least a 1/8" gap between the bottom of the door track and the surface of the finish material.**

Non-combustible materials, such as surrounds and other appliance trim, may be installed on the appliance front face with the exceptions.

Vertical installation clearances to combustible mantels vary according to the depth of the mantel. See **Figure 42**. Mantels constructed of non-combustible materials may be installed at any height above the appliance opening.

Combustible materials may project beyond the sides of the fireplace opening as long as they are kept within the shaded areas illustrated in **Figure 43**.

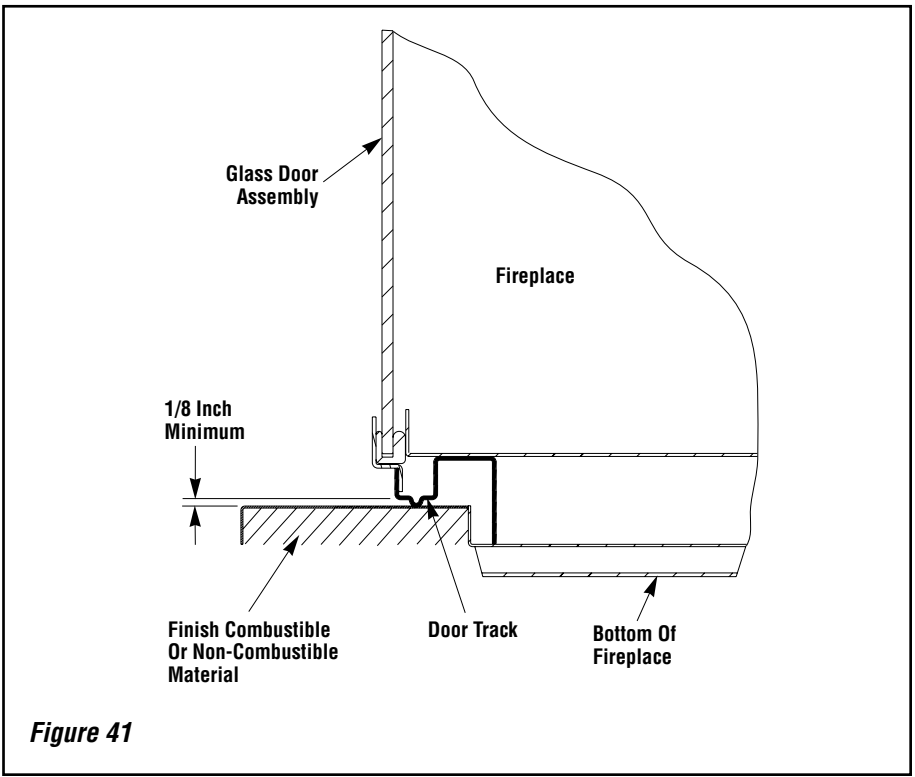

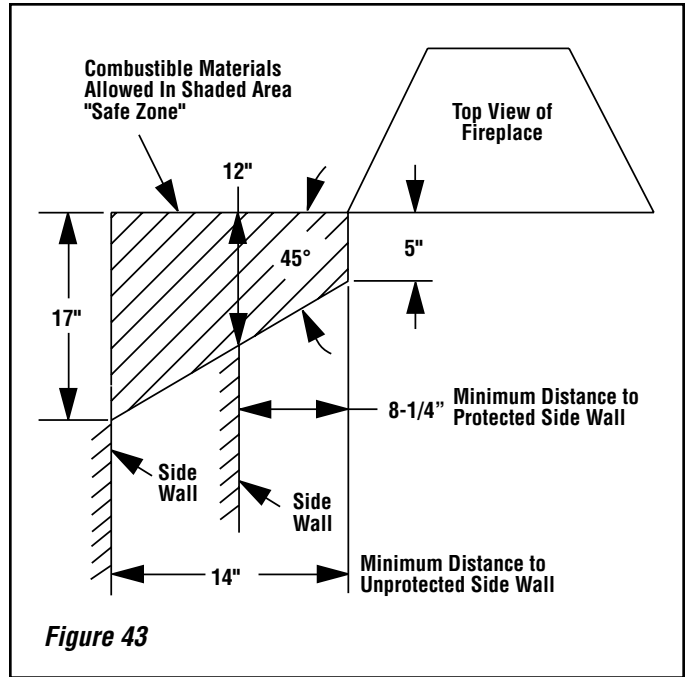
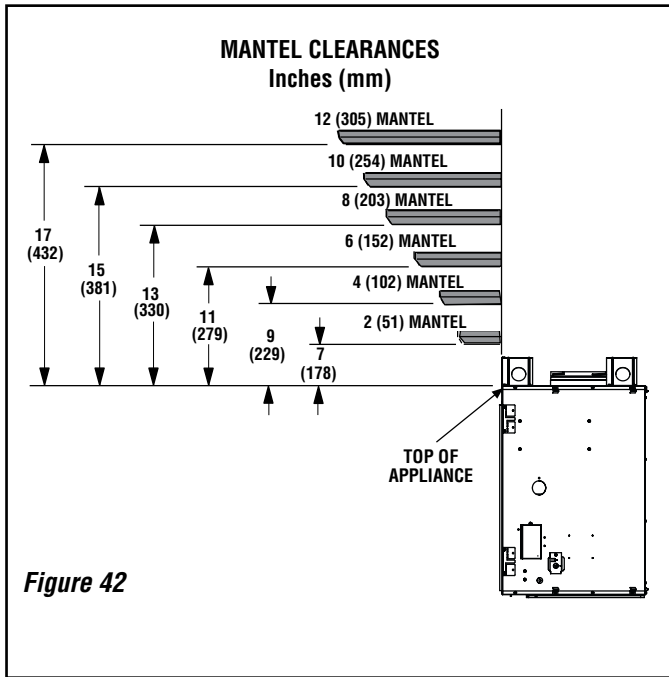

COLD CLIMATE INSULATION

For cold climate installations, seal all cracks around your appliance with noncombustible material and wherever cold air could enter the room. It is especially important to insulate outside chase cavity between studs and under floor on which appliance rests, if floor is above ground level. Gas line holes and other openings should be caulked or stuffed with unfaced fiberglass insulation. In cold climates, if the fireplace is being installed on a cement slab, a sheet of plywood or other raised platform can be placed underneath to prevent conducting cold up into the room. It also helps to sheetrock inside surfaces and tape for maximum airtightness and caulk firestops.

INSTALLATION ACCESSORIES

	Cat. No.	Model No.	Description
	H6179	SV8CTS-B	Chase Top Termination, Black
	H6180	SV8CTS-TC	Chase Top Termination, Terra Cotta

INSTALLATION ACCESSORIES

Listed Secure Vent™ Components			
	Cat. No.	Model No.	Description
	H2266	SV8HTS	Horizontal Square Termination with Firestop/Spacer (H2260) and Adapter (H2267)
	H2265	SV8VTR	Vertical Termination
	H2250	SV8L6	6 inch (152mm) Vent Section
	H2251	SV8L12	12 inch (305mm) Vent Section
	H2252	SV8L24	24 inch (610mm) Vent Section
	H2253	SV8L36	36 inch (914mm) Vent Section
	H2254	SV8L48	48 inch (1219mm) Vent Section
	H2255	SV8LA	Telescopic Section
	H2256	SV8E45	45 Degree Elbow
	H2257	SV8E90	90 Degree Elbow
	The following flashings come packaged with a storm collar		
	H3236	SV8F	Flat Roof Flashing
	H2258	SV8FA	1/12 to 7/12 Adjustable Flashing
	H2259	SV8FB	7/12 to 12/12 Adjustable Flashing
	H3237	SV8SC6	Storm Collars, 6 pack
	H2260	SV8HF	Firestop/Spacer - Horizontal (3 - 1 - 1 spacing)
	H2261	SV8BF	Firestop/Spacer - Vertical (1 - 1 - 1 spacing)

	H2262	SV8SU	Support Strap
	H2263	SV8SP	Support Plate
	H3908	SV8ARSA	Attic Insulation Shield (adjustable 12" to 22")

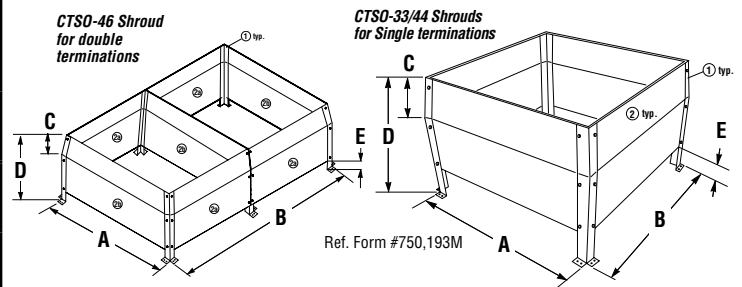

Open Top Shroud Kits Inches (millimeters)						
Cat. No.	Model	A	B	C	D	*E
H1985	CTS0-33	37-5/8 (955)	37-5/8 (955)	7-1/2 (191)	24-1/2 (622)	3 (76)
H1987	CTS0-44	48-5/8 (1235)	48-5/8 (1235)	7-1/2 (191)	24-1/2 (622)	3 (76)
H1986	CTS0-46	48-5/8 (1235)	73 1/4 (1860)	7-1/2 (191)	24-1/2 (622)	3 (76)

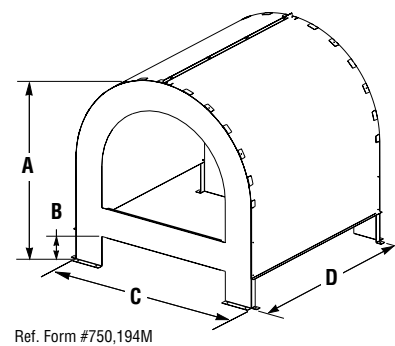

Closed Top Shroud Termination Kits Inches (millimeters)					
Cat. No.	Model	A	B	C	D
H1988	CTSA-33	34" (864)	5" (127)	34" (864)	34" (864)

NOTE: DIAGRAMS & ILLUSTRATIONS ARE NOT TO SCALE.

GAS CONVERSION KITS

⚠ WARNING

This conversion kit shall be installed by a qualified service agency in accordance with the manufacturer's instructions and all applicable codes and requirements of the authorized having jurisdiction. If the information in these instructions is not followed exactly, a fire, explosion or production of carbon monoxide may result causing property damage, personal injury or loss of life. The installation is not proper and complete until the operation of the converted appliance is checked as specified in the owner instructions supplied with the kit. The qualified service agency performing this installation assumes responsibility for this conversion.

⚠ AVERTISSEMENT

Cet équipement de conversion sera installé par une agence qualifiée de service conformément aux instructions du fabricant et toutes exigences et codes applicables de l'autorisation avoir la juridiction. Si l'information dans cette instruction n'est pas suivie exactement, un feu, explosion ou production de protoxyde de carbone peut résulter le dommages causer de propriété, perte ou blessure personnelle de vie. L'agence qualifiée de service est esponsable de l'installation propre de cet équipement. L'installation n'est pas propre et complète jusqu'à l'opération de l'appareil converti est chèque suivant les critères établis dans les instructions de propriétaire provisionnées avec l'équipement.

In Canada:

⚠ IMPORTANT/CANADA

The conversion shall be carried out in accordance with the requirements of the provincial authorities having jurisdiction and in accordance with the requirements of the CAN1-B149.1 And B149.2 Installation code.

⚠ ATTENTION/CANADA

La conversion devra être effectuée conformément aux recommandations des autorités provinciales ayant juridiction et conformément aux exigences du code d'installation CAN1-B149.1 ET.2.

Gas conversion kits are available to adapt your appliance from the use of one type of gas to the use of another. These kits contain all the necessary components needed to complete the task including labeling that must be affixed to ensure safe operation.

Kit part numbers are listed here and the following steps detail the conversion procedure.

Natural Gas To Propane Gas Conversion Kit		
Model No.	Unit Type	Cat. No.
LSM40MP-2	Millivolt	H2268
LSM45MP-2	Millivolt	H4811
LSM40EN-2	Electronic	H3238
LSM45EN-2	Electronic	H4813

Propane to Natural Gas Conversion Kit		
Model No.	Unit Type	Cat. No.
LSM40EN-2	Millivolt	H2269
LSM45EN-2	Millivolt	H2271

Step 1. Turn off the gas supply to the appliance. Remove the front glass door/frame and the access plate from the appliance.

Step 2. Carefully remove the logs and the grate assembly. **Exercise care so as not to break the logs.**

Step 3. Refer to **Figure 44**. Remove the burner assembly with attached venturi tube.

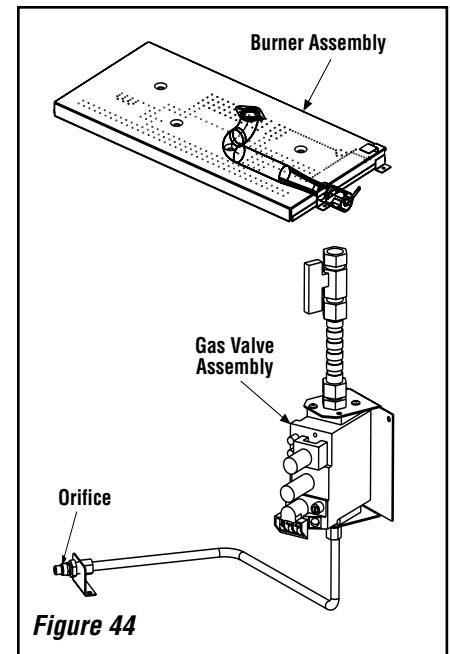
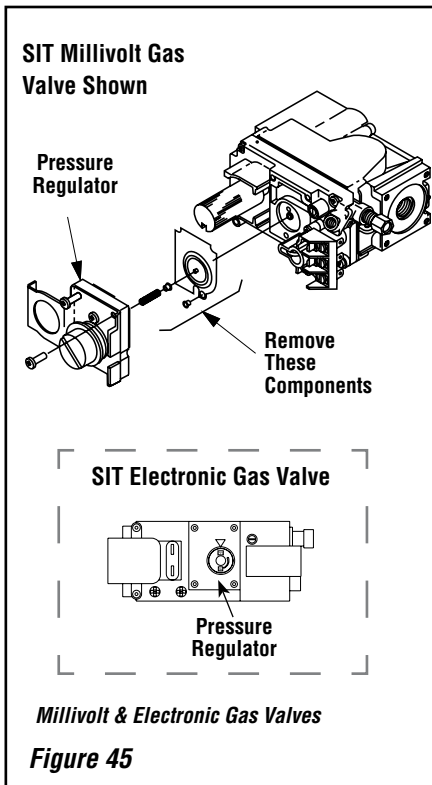

Figure 44

Step 4. Refer to **Figure 45 on Page 27** and the instructions provided with the kit. Using a Torx T20 (with 1/4" shank and center hole), remove and discard the three pressure regulator mounting screws. Remove the pressure regulator, spring, poppet, diaphragm and bushing. **Discard all removed components.** Ensure the rubber gasket installed on the back of the replacement pressure regulator is properly positioned and install the new pressure regulator using the new screws supplied with the kit. Tighten screws to 25 In. lb. torque.



Step 5. Attach manometer to the manifold side pressure test fitting and verify manifold pressure reads 3.5 inches water column (0.87 kPa) for natural gas, and 10.0 inches water column (2.49 kPa) for propane gas.

Step 6. Refer to **Figure 46** and remove the pilot hood assembly to access the hexed pilot orifice. Remove and replace the orifice with the one provided with the kit.

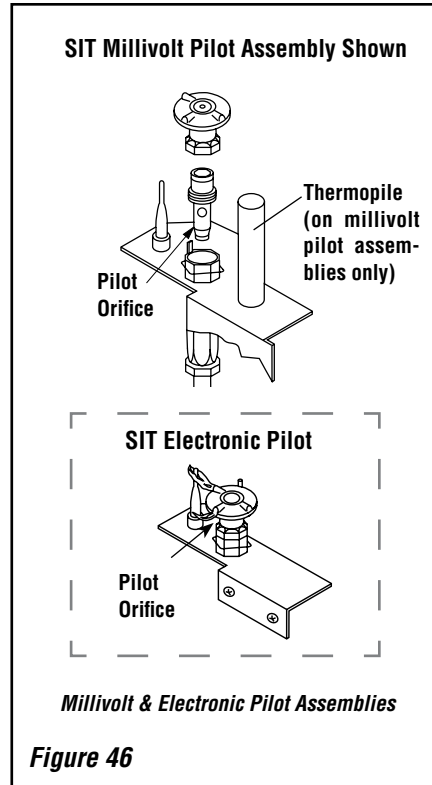

Step 7. (Refer to **Figure 44 on Page 26**)

A. Remove the orifice from the manifold and replace it with the one provided in the kit. See the following table for orifice sizes for natural and propane models. **Figure 47** illustrates the orifice. Use pipe joint compound or Teflon tape when installing the orifice.

B. Retrieve the burner and slide the venturi tube over the orifice. Set the burner assembly into its position and secure it.

C. Reinstall the grate assembly.

Model	Orifice Size		Elevation Feet (meters)
	Nat.	Prop.	
LSM40-2	.1405" (#28)	.086" (#44)	0-4500 (0-1372)
LSM45-2	.161" (#20)	.093" (#42)	

Table 7

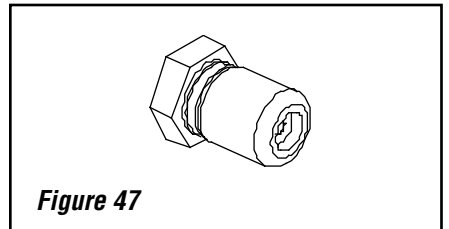

Step 8. Reassemble the remaining components by reversing the procedures outlined in the preceding steps.

Step 9. Attach the conversion label provided in the conversion kit to the rating plate on the appliance.

Step 10. Turn on gas supply and test for gas leaks.

Lennox Hearth Products reserves the right to make changes at any time, without notice, in design, materials, specifications, prices and also to discontinue colors, styles and products. Consult your local distributor for fireplace code information.

Printed in U.S.A. © 2005 by Lennox Hearth Products

P/N 850,026M REV. D 08/2007



HEARTH PRODUCTS

1110 West Taft Avenue • Orange, CA 92865