

This Owner's Manual is provided and hosted by [Appliance Factory Parts](#).



# Black & Decker PD1200 Owner's Manual

[Shop genuine replacement parts for Black & Decker  
PD1200](#)



[Find Your Black & Decker Vacuum Cleaner Parts - Select From 339 Models](#)

----- Manual continues below -----

## Powerful Solutions™

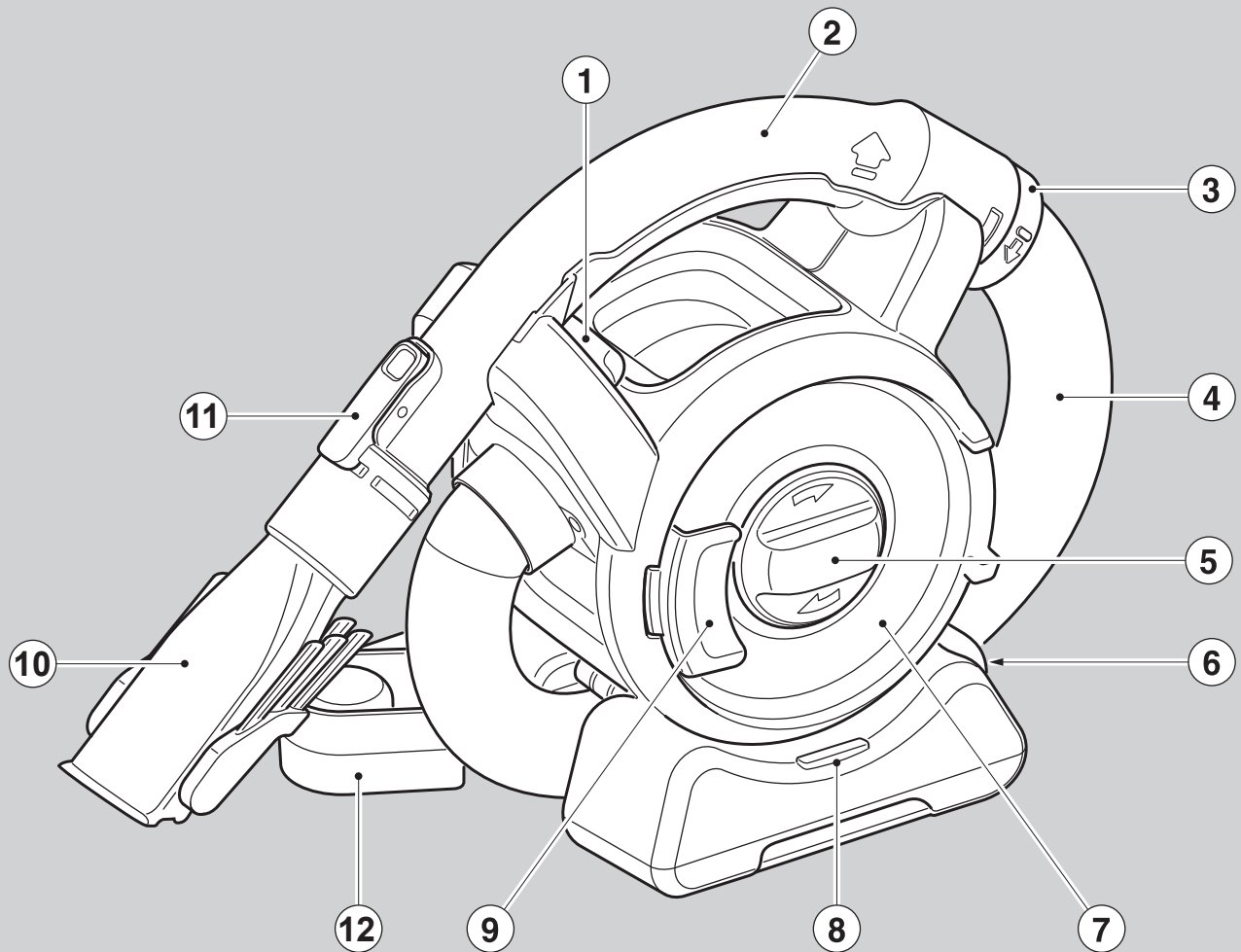

[www.blackanddecker.co.uk](http://www.blackanddecker.co.uk)

PD1200  
PD1080



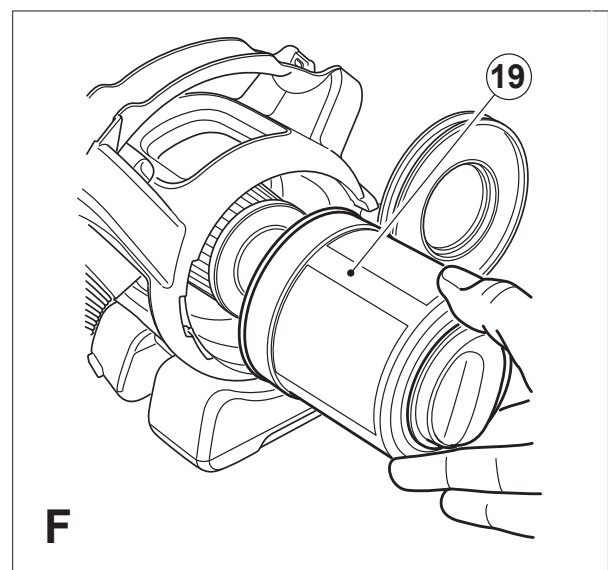
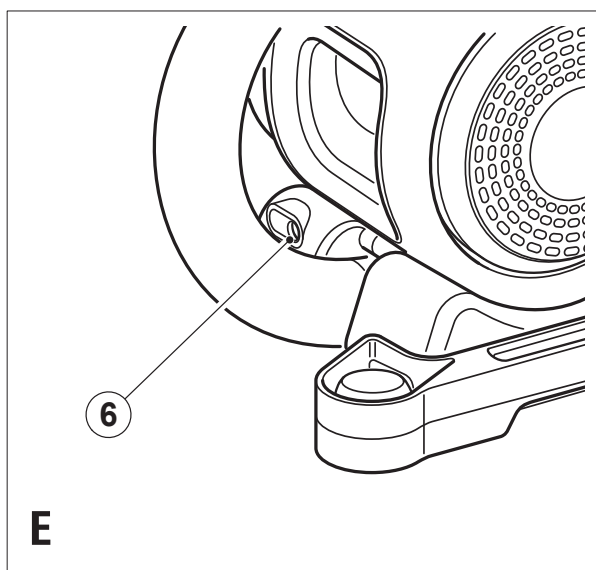
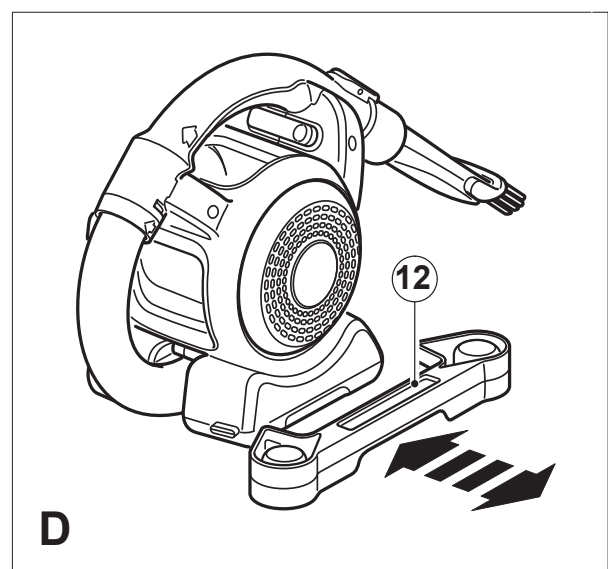
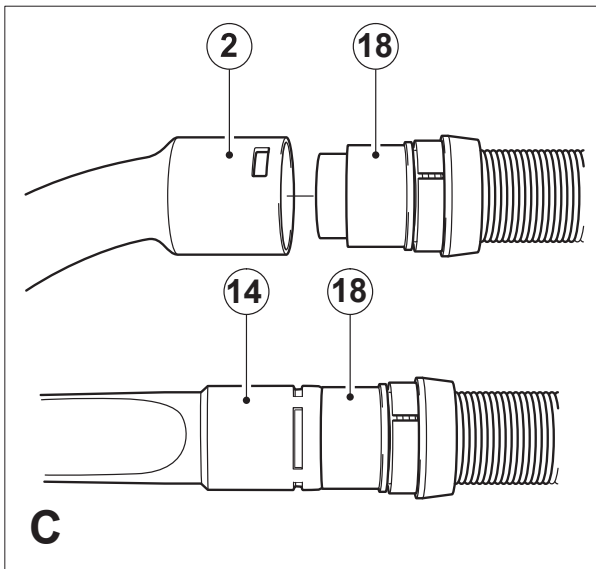
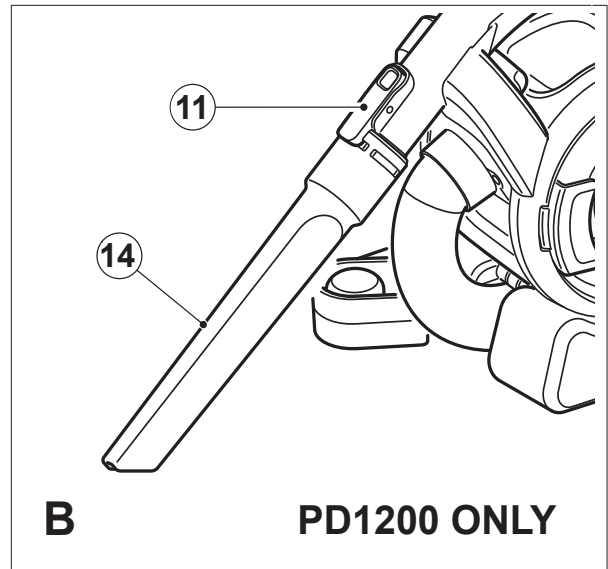
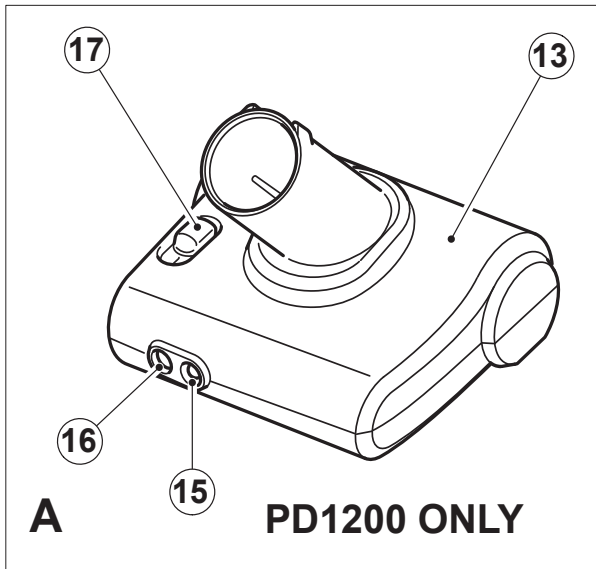

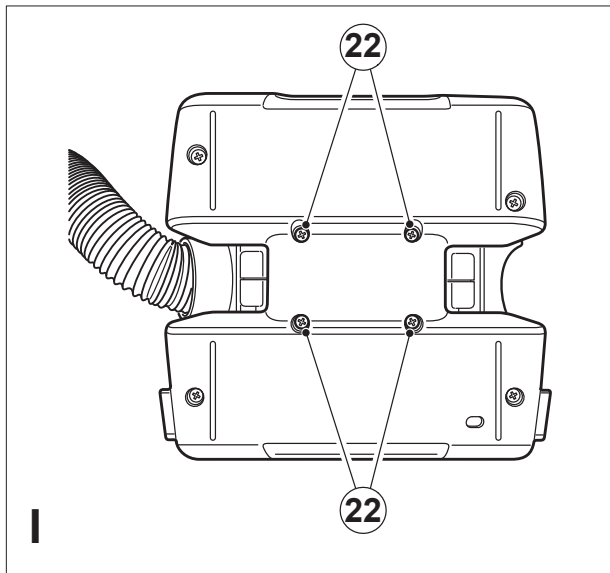
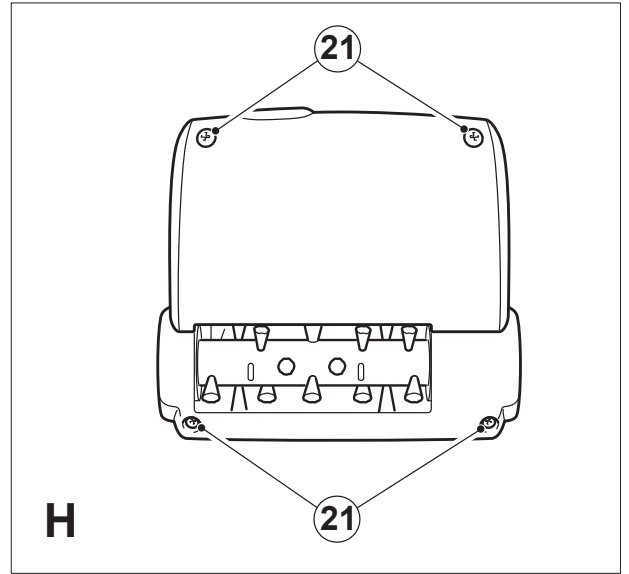
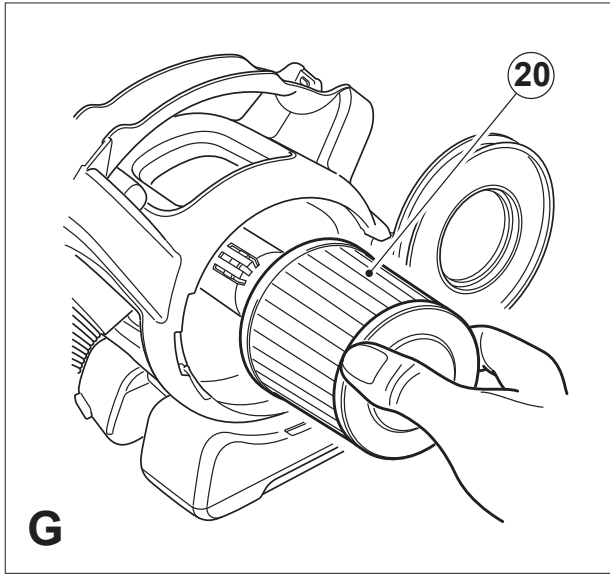

## Intended use

Your Black & Decker Dustbuster Flexi™ vacuum cleaner has been designed for dry vacuum cleaning purposes. This appliance is intended for household use only.

## Safety instructions

**Warning!** When using battery-powered appliances, basic safety precautions, including the following, should always be followed to reduce the risk of fire, leaking batteries, personal injury and material damage.

- ◆ Read all of this manual carefully before using the appliance.
- ◆ The intended use is described in this manual. The use of any accessory or attachment or the performance of any operation with this appliance other than those recommended in this instruction manual may present a risk of personal injury.
- ◆ Retain this manual for future reference.

### Using your appliance

- ◆ Do not use near water.
- ◆ Do not use the appliance to pick up liquids or any materials that could catch fire.
- ◆ Do not immerse the appliance in water.
- ◆ Never pull the charger lead to disconnect the charger from the socket. Keep the charger lead away from heat, oil and sharp edges.
- ◆ This tool is not intended for use by persons (including children) with reduced physical, sensory or mental capabilities, or lack of experience and knowledge, unless they have been given supervision or instruction concerning use of the appliance by a person responsible for their safety.
- ◆ Children should be supervised to ensure that they do not play with the appliance.

### After use

- ◆ Unplug the charger before cleaning the charger or charging base.
- ◆ When not in use, the appliance should be stored in a dry place.
- ◆ Children should not have access to stored appliances.

### Inspection and repairs

- ◆ Before use, check the appliance for damaged or defective parts. Check for breakage of parts, damage to switches and any other conditions that may affect its operation.
- ◆ Do not use the appliance if any part is damaged or defective.
- ◆ Have any damaged or defective parts repaired or replaced by an authorized repair agent.

- ◆ Regularly check the charger lead for damage. Replace the charger if the lead is damaged or defective.
- ◆ Never attempt to remove or replace any parts other than those specified in this manual.

## Additional safety instructions - batteries and chargers

### Batteries

- ◆ Never attempt to open for any reason.
- ◆ Do not expose the battery to water.
- ◆ Do not expose the battery to heat.
- ◆ Do not store in locations where the temperature may exceed 40°C.
- ◆ Charge only at ambient temperatures between 10°C and 40°C.
- ◆ Charge only using the charger provided with the appliance/tool. Using the wrong charger could result in an electric shock or overheating of the battery.
- ◆ When disposing of batteries, follow the instructions given in the section "Protecting the environment".
- ◆ Do not damage/deform the battery pack either by puncture or impact, as this may create a risk of injury and fire.
- ◆ Do not charge damaged batteries.
- ◆ Under extreme conditions, battery leakage may occur. When you notice liquid on the batteries carefully wipe the liquid off using a cloth. Avoid skin contact.
- ◆ In case of skin or eye contact, follow the instructions below.

**Warning!** The battery fluid may cause personal injury or damage to property. In case of skin contact, immediately rinse with water. If redness, pain or irritation occurs seek medical attention. In case of eye contact, rinse immediately with clean water and seek medical attention.

### Chargers

Your charger has been designed for a specific voltage. Always check that the mains voltage corresponds to the voltage on the rating plate.

**Warning!** Never attempt to replace the charger unit with a regular mains plug.

- ◆ Use your Black & Decker charger only to charge the battery in the appliance/tool with which it was supplied. Other batteries could burst, causing personal injury and damage.
- ◆ Never attempt to charge non-rechargeable batteries.
- ◆ If the supply cord is damaged, it must be replaced by the manufacturer or an authorised Black & Decker Service Centre in order to avoid a hazard.
- ◆ Do not expose the charger to water.
- ◆ Do not open the charger.
- ◆ Do not probe the charger.

The appliance/tool/battery must be placed in a well ventilated area when charging.

### Electrical safety

Your charger has been designed for a specific voltage. Always check that the mains voltage corresponds to the voltage on the rating plate. Never attempt to replace the charger unit with a regular mains plug.



This appliance is double insulated; therefore no earth wire is required. Always check that the power supply corresponds to the voltage on the rating plate.



The charger is intended for indoor use only.



Read the instruction manual before use.



The charger automatically shuts off if the ambient temperature becomes too high. As soon as the ambient temperature has cooled down, the charger will resume operating.



Charge only at ambient temperatures between 10°C and 40°C.

### Features

This appliance includes some or all of the following features.

1. On/off power switch
2. Removable hose/handle
3. Locking ring
4. Hose
5. Filter cleaning wheel
6. Charging inlet
7. Transparent door
8. LED charging indicator
9. Door latch
10. 2-in-1 combi nozzle accessory
11. Accessory clip

The following accessories are only available with model number PD1200 (fig. A & B):

12. Accessory caddy
13. Powered brush head
14. Crevice tool

The powered brush head is not included with all models.

### Assembly

#### Mounting accessories (fig. A, B & C)

The 2-in-1 combi nozzle (10) has a brush that can be folded forward for dusting and upholstery cleaning.

The crevice tool (14) allows for vacuuming in narrow and hard to-reach places.

The powered brush head (13) has its own rechargeable batteries and is charged separately from the appliance, refer to "Charging the battery" section.

- ◆ To fit an accessory press the accessory clip (11) and slide the accessory onto the handle (2).
- ◆ To remove an accessory, press the accessory clip (11) and remove the accessory.

The handle (2) can be removed from the hose (4) allowing the accessories to be connected directly to the hose cuff (18) when required. To remove the handle:

- ◆ Unclip the handle (2) from the appliance.
- ◆ Rotate the locking ring (3) anti-clockwise to release the clips.
- ◆ Pull the hose (4) away from the handle (2).
- ◆ Fit the accessory directly to the hose cuff (18).

To refit the handle:

- ◆ Remove the accessory from the hose.
- ◆ Push the hose (4) into the handle (2). Rotate the locking ring (3) clockwise until it clicks into place.

#### Fitting the accessory caddy (PD1200) (fig. D)

When not in use, accessories can be stored in the accessory caddy (12). The accessory caddy can be removed if necessary.

- ◆ To install the accessory caddy (12) slide it onto the lugs on the body of the appliance until it clicks into place.
- ◆ To remove the accessory caddy (12) pull it away from the base of the appliance.

#### Residual risks

Additional residual risks may arise when using the tool which may not be included in the enclosed safety warnings. These risks can arise from misuse, prolonged use etc.

Even with the application of the relevant safety regulations and the implementation of safety devices, certain residual risks cannot be avoided. These include:

- ◆ Injuries caused by touching any rotating/moving parts.
- ◆ Injuries caused when changing any parts, blades or accessories.
- ◆ Injuries caused by prolonged use of a tool. When using any tool for prolonged periods make sure you take regular breaks.
- ◆ Impairment of hearing.
- ◆ Health hazards caused by breathing dust developed when using your tool (example:- working with wood, especially oak, beech and MDF).

## Use

Before first use, the batteries must be charged for at least 24 hours.

- ◆ Connect the appliance and the powered brush head (13) to the charger for a minimum of 24 hours.
- ◆ Charge the batteries as described below.

You may need to charge/discharge the appliance a minimum of 5 times in order to achieve the best running time performance.

### Charging the battery (fig. A & E)

**Warning!** Do not charge the battery at ambient temperatures below 10°C or above 40°C.

**Note:** If your vacuum cleaner is supplied with a single charger with a dual lead to charge both the appliance and the powered brush head (13), the jack plugs are the same size and are interchangeable. The appliance and the powered brush head (13) can be charged at the same time.

To charge the appliance:

- ◆ Make sure that the appliance is switched off. The battery will not be charged with the on/off power switch (1) in the on position.
- ◆ Insert the plug into the charging inlet (6) in the base.
- ◆ Plug in the charger and switch on at the mains.
- ◆ The charging indicator (8) will be lit.
- ◆ For the first charging, leave the appliance to charge for at least 24 hours.

To charge the powered brush head:

- ◆ Make sure that the powered brush head (13) is switched off. The battery will not be charged with the on/off power switch (17) in the on position.
- ◆ Insert the plug into the charger inlet (16).
- ◆ Plug in the charger and switch on at the mains.
- ◆ The charging indicator (15) will be lit.
- ◆ For the first charging, leave the appliance to charge for at least 24 hours.

While charging, the charger may become warm. This is normal and does not indicate a problem.

While it is safe to leave the appliance/powered brush head connected to the charger indefinitely, to reduce power consumption, we would recommend unplugging the charger after 24 hours. The charging indicators will be lit as long as the appliance is connected to the plugged-in charger.

### Switching on and off

- ◆ To switch the appliance on, slide the on/off power switch (1) to the right to position 1.
- ◆ To switch the appliance off, slide the on/off power switch (1) to the left until it clicks into the off position.

## Vacuuming

- ◆ When operating the appliance, make sure that the hose is not trapped, twisted or blocked.
- ◆ The handle (2) can be easily removed from the appliance allowing you to reach up to 1.5 m from the appliance.
- ◆ With the handle (2) removed, the appliance can be carried using the built-in handle.
- ◆ The handle (2) can also be removed from the hose (4) so that you can connect an accessory directly to the hose cuff (18) when required.

### Hints for optimum use

- ◆ When working in confined spaces, temporarily remove the accessory caddy (12) from the base to improve your scope.
- ◆ When vacuuming stairs, always start at the bottom and work your way up.

### Using the powered brush head (fig. A)

The powered brush head (13) can only be used with the handle removed from the appliance.

- ◆ To switch the powered brush head to on, move the on/off switch (17) to the on position .
- ◆ slide the on/off power switch (1) to the on position.
- ◆ Move the powered brush head (13) steadily backwards and forwards. Do not keep the brush on the same place for a long time, as this might damage the surface.
- ◆ Move the on/off switch (17) to the off position to switch the powered brush head off.

### Optimising the suction force

In order to keep the suction force optimised, the filters must be cleared regularly during use.

- ◆ Turn the filter cleaning wheel (5) two turns clockwise to remove out any dust from the filters.
- ◆ The fine particulate filter must be cleaned regularly, see "Cleaning the fine particulate filter" section.

## Cleaning and maintenance

### Emptying the dust container (fig. F)

The dust container must be emptied regularly, preferably after every use.

- ◆ Release the door catch (9) and open the transparent door (7) 180° until it clicks in the open position.
- ◆ Remove the pre-filter (19).
- ◆ Empty the dust container.
- ◆ Clean the pre-filter (19) by lightly shaking over a dustbin.
- ◆ Refit the pre-filter (19).

- ◆ Close the transparent door (7) and make sure that it clicks into place.

**Warning!** Do not, under any circumstances, rinse out the dust container.

**Warning!** Do not immerse the appliance in water. A damp cloth and soapy water should be used to clean the exterior of the appliance. Always make sure that the appliance is completely dry before re-use or storing.

### Cleaning the fine particulate filter (fig. H)

The fine particulate filter (20) prevents particles and larger objects from entering the motor housing.

The filter (20) is re-usable and should be cleaned regularly.

- ◆ Remove the pre-filter (19) from the appliance as described above.
- ◆ Remove the fine particulate filter (20) by pulling firmly.
- ◆ Tap the filter vigorously to remove loose dust from the filter.
- ◆ If necessary, wash the filter in warm, soapy water.
- ◆ Make sure that the filters are dry.
- ◆ Refit the fine particulate filter (20) on to the appliance.
- ◆ Refit the pre-filter (19) as described above.

### Clearing the powered brush head (fig. H)

- ◆ Remove any hair or threads that have collected on the brush, use a pair of scissors if necessary.

### Replacing the filters

The filters should be replaced every 6 to 9 months and whenever worn or damaged. Replacement filters are available from your Black & Decker dealer (cat. no. PD10):

- ◆ Remove the old filters as described above.
- ◆ Fit the new filters as described above.

## Protecting the environment



Separate collection. This product must not be disposed of with normal household waste.

Should you find one day that your Black & Decker product needs replacement, or if it is of no further use to you, do not dispose of it with household waste. Make this product available for separate collection.



Separate collection of used products and packaging allows materials to be recycled and used again. Re-use of recycled materials helps prevent environmental pollution and reduces the demand for raw materials.

Local regulations may provide for separate collection of electrical products from the household, at municipal waste sites or by the retailer when you purchase a new product.

Black & Decker provides a facility for the collection and recycling of Black & Decker products once they have reached the end of their working life. To take advantage of this service please return your product to any authorised repair agent who will collect them on our behalf.

You can check the location of your nearest authorised repair agent by contacting your local Black & Decker office at the address indicated in this manual. Alternatively, a list of authorised Black & Decker repair agents and full details of our after-sales service and contacts are available on the Internet at: [www.2helpU.com](http://www.2helpU.com).

### Batteries



Black & Decker batteries can be recharged many times. At the end of their useful life, discard batteries with due care for our environment.:

If you want to dispose of the product yourself, the batteries must be removed as described below and disposed of in accordance with local regulations.

- ◆ Discharge the battery by operating the appliance until the motor stops.
- ◆ Invert the appliance to get access to the screws that attach the base (fig. H & I).
- ◆ Remove the 4 screws (21 or 22).
- ◆ Remove the base.
- ◆ Disconnect the 3-pin connector.
- ◆ Place the battery in suitable packaging to ensure that the terminals cannot be short-circuited.
- ◆ NiHM batteries are recyclable. Take them to any authorised repair agent or a local recycling station.

## Technical data

	PD1200 H2	PD1080 H2
Voltage	Vdc 12	10.8
Weight	kg 1.8	1.75

Charger	*A170020D
Input voltage	Vac 230
Output voltage	Vac 17
Output current	mA 200
Approx. charging time	h 24
Weight	kg 0.2

Powered brush head	
Voltage	Vdc 2.4
Brush rotation	rpm 2500

Level of sound pressure, measured according to EN 60704-1: = 72 dB(A)

## Guarantee

Black & Decker is confident of the quality of its products and offers an outstanding guarantee. This guarantee statement is in addition to and in no way prejudices your statutory rights. The guarantee is valid within the territories of the Member States of the European Union and the European Free Trade Area.

If a Black & Decker product becomes defective due to faulty materials, workmanship or lack of conformity, within 24 months from the date of purchase, Black & Decker guarantees to replace defective parts, repair products subjected to fair wear and tear or replace such products to make sure of the minimum inconvenience to the customer unless:

- ◆ The product has been used for trade, professional or hire purposes.
- ◆ The product has been subjected to misuse or neglect.
- ◆ The product has sustained damage through foreign objects, substances or accidents.
- ◆ Repairs have been attempted by persons other than authorised repair agents or Black & Decker service staff.

To claim on the guarantee, you will need to submit proof of purchase to the seller or an authorised repair agent. You can check the location of your nearest authorised repair agent by contacting your local Black & Decker office at the address indicated in this manual. Alternatively, a list of authorised Black & Decker repair agents and full details of our after-sales service and contacts are available on the Internet at:

**[www.2helpU.com](http://www.2helpU.com)**

Please visit our website **[www.blackanddecker.co.uk](http://www.blackanddecker.co.uk)** to register your new Black & Decker product and to be kept up to date on new products and special offers. Further information on the Black & Decker brand and our range of products is available at **[www.blackanddecker.co.uk](http://www.blackanddecker.co.uk)**.

Partial support - Only parts shown available  
Nur die aufgeführten teile sind lieferbar  
Reparation partielle - Seules les pieces indiquees sont disponibles  
Supporto parziale - Sono disponibili soltanto le parti evidenziate  
Solo estan disponibles las peizas listadas  
Gedeeltelijke ondersteuning - alleen de getoonde onderdelen zijn beschikbaar

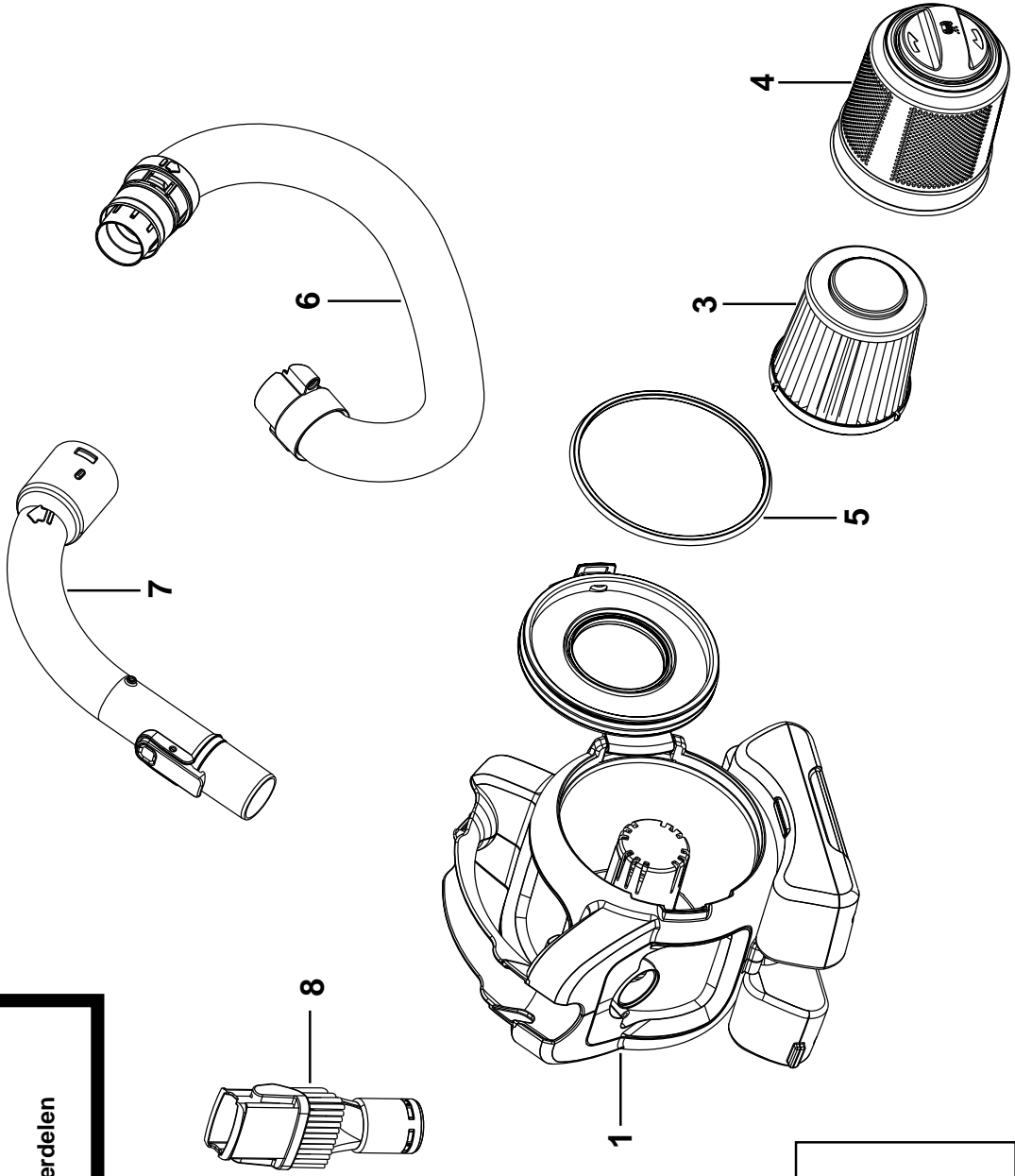
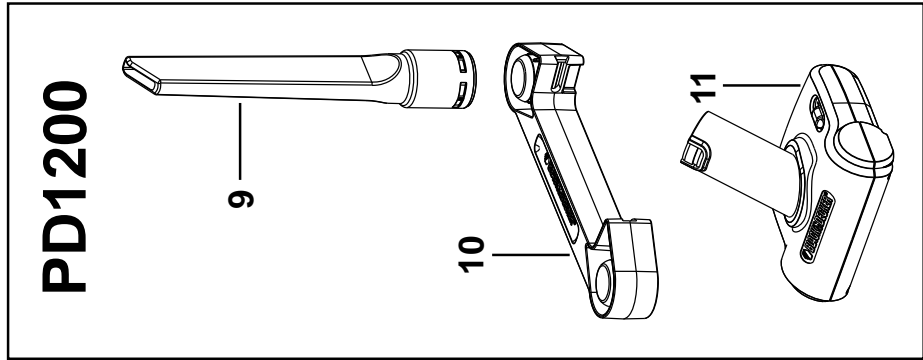

ENGLISH

**Do not forget to register your product!**

**[www.blackanddecker.co.uk/productregistration](http://www.blackanddecker.co.uk/productregistration)**

Register your product online at **[www.blackanddecker.co.uk/productregistration](http://www.blackanddecker.co.uk/productregistration)** or send your name, surname and product code to Black & Decker in your country.

**Australia**

Black & Decker (Australia) Pty. Ltd.  
20 Fletcher Road, Mooroolbark,  
Victoria, 3138

Tel. 03-8720 5100  
Fax 03-9727 5940

**New Zealand**

Black & Decker  
5 Te Apunga Place  
Mt Wellington  
Auckland 1060

Tel. +64 9 259 1133  
Fax +64 9 259 1122

**United Kingdom**

Black & Decker  
210 Bath Road  
Slough, Berkshire SL1 3YD

Tel. 01753 511234  
Fax 01753 551155  
Helpline 01753 574277