

This Owner's Manual is provided and hosted by [Appliance Factory Parts](#).



Black & Decker FV1205 Owner's Manual

[Shop genuine replacement parts for Black & Decker
FV1205](#)



[Find Your Black & Decker Vacuum Cleaner Parts - Select From 339 Models](#)

----- Manual continues below -----

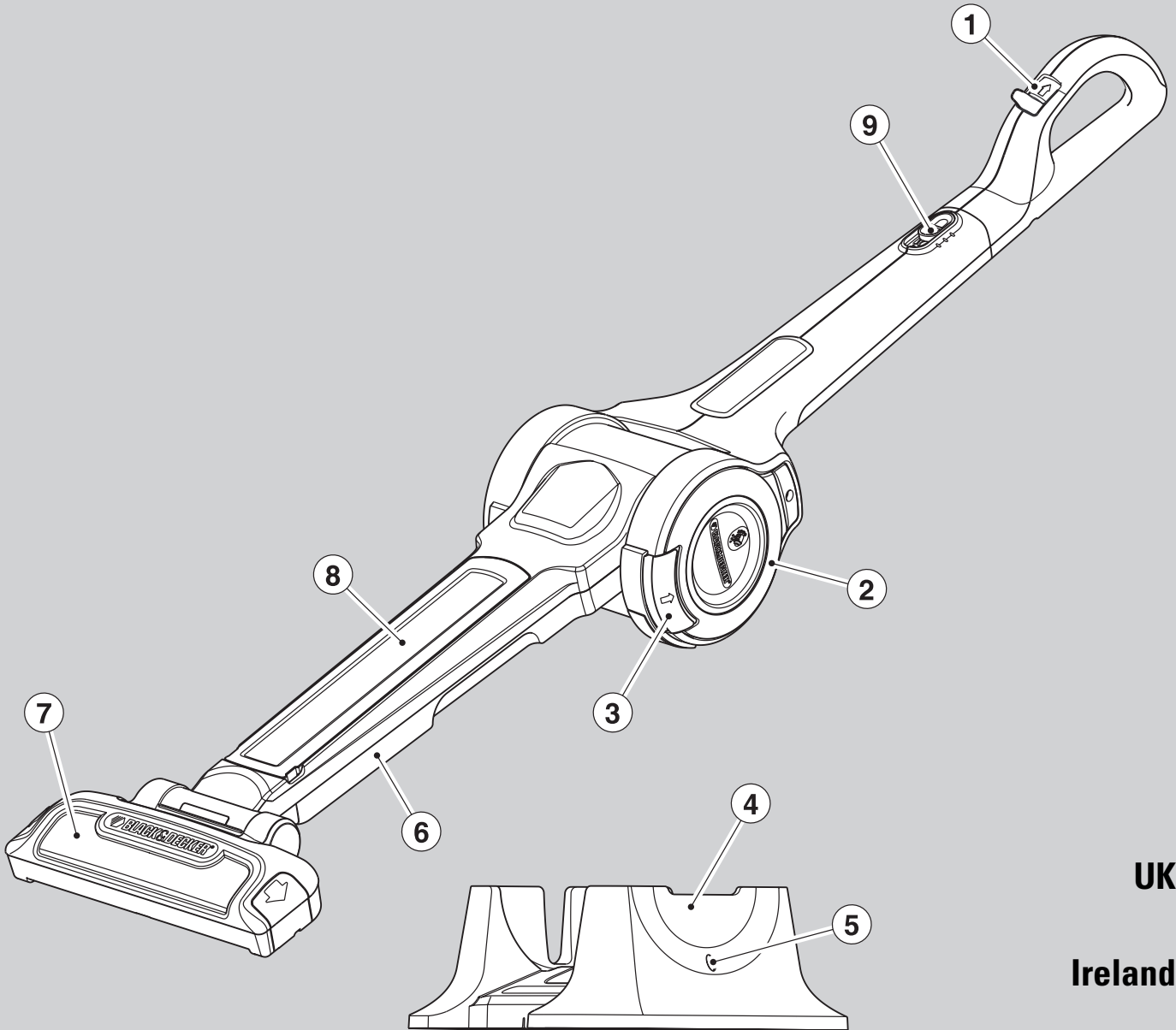

UK

Ireland

Australia

New Zealand

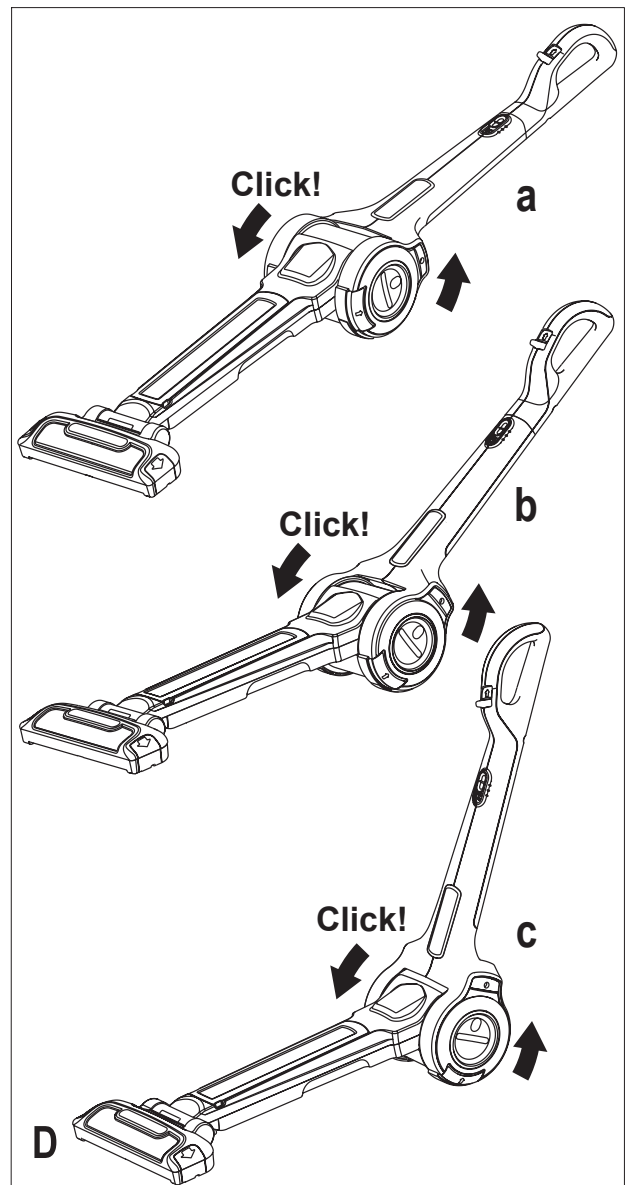
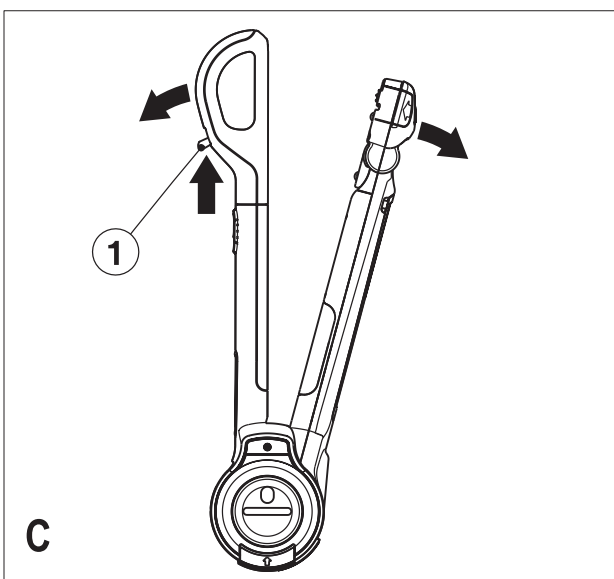
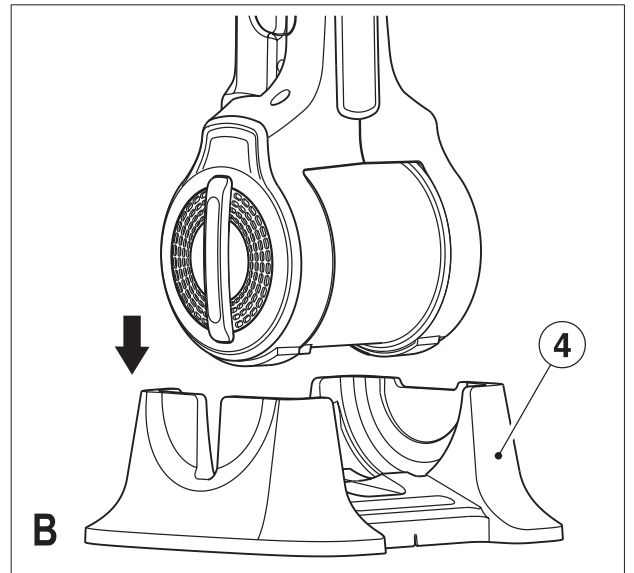
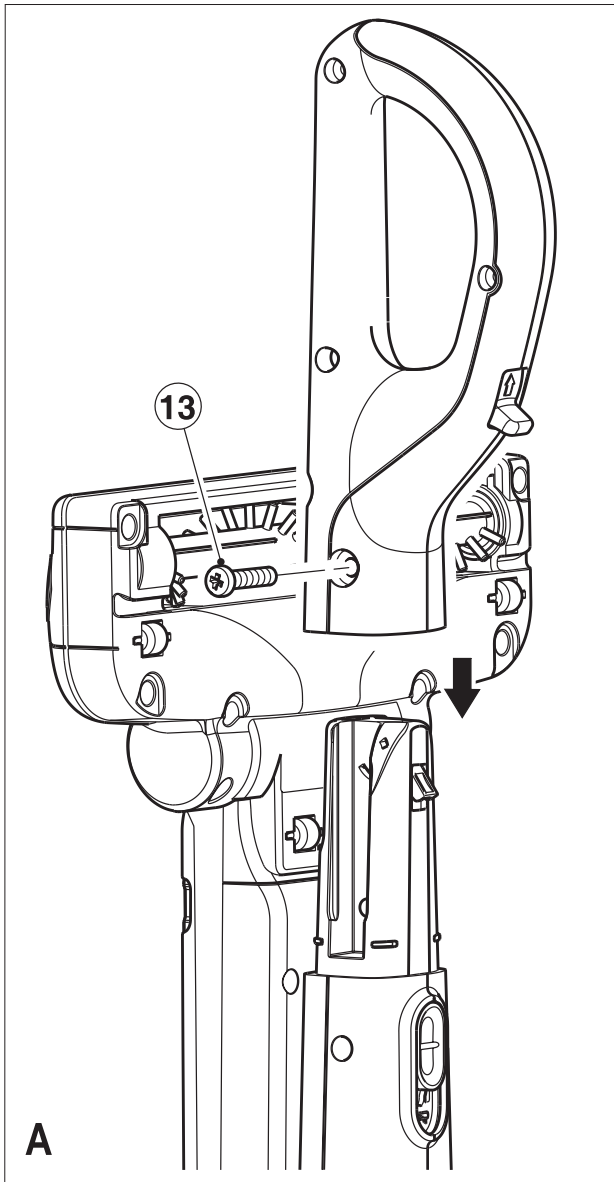

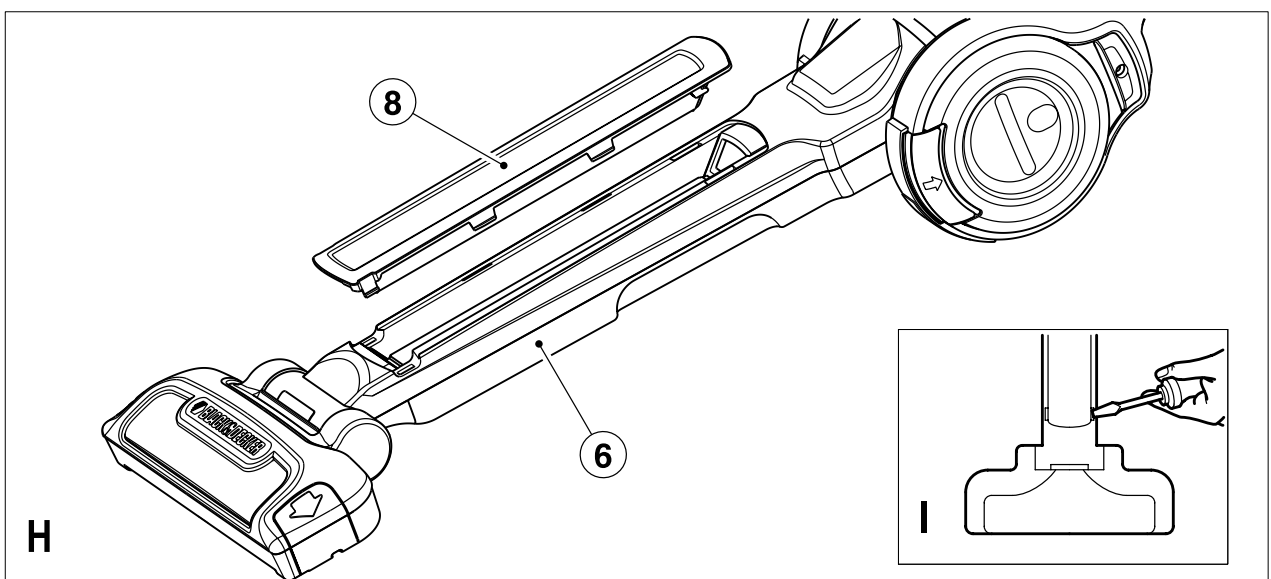
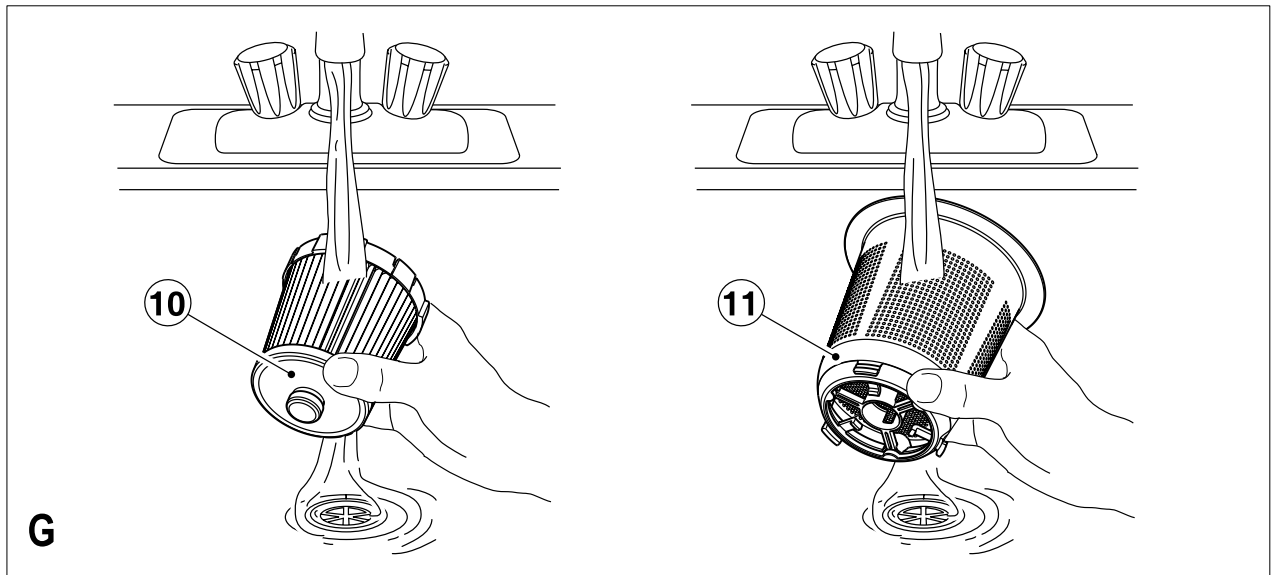
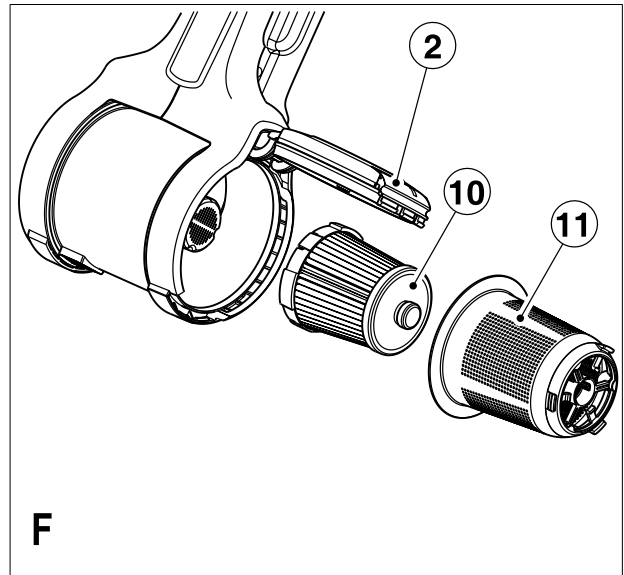
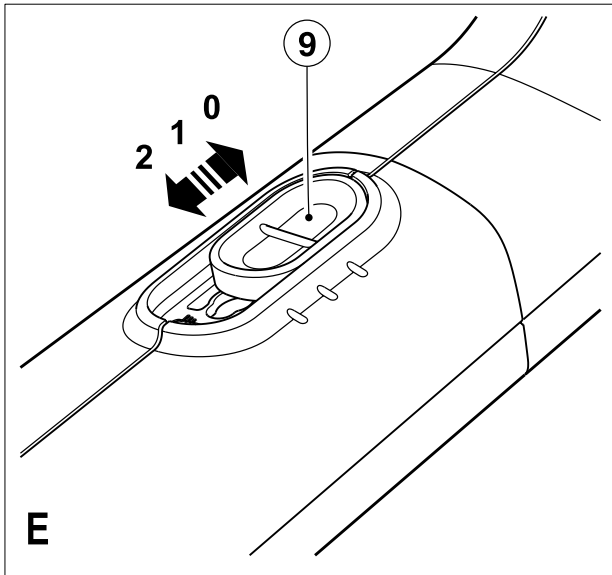

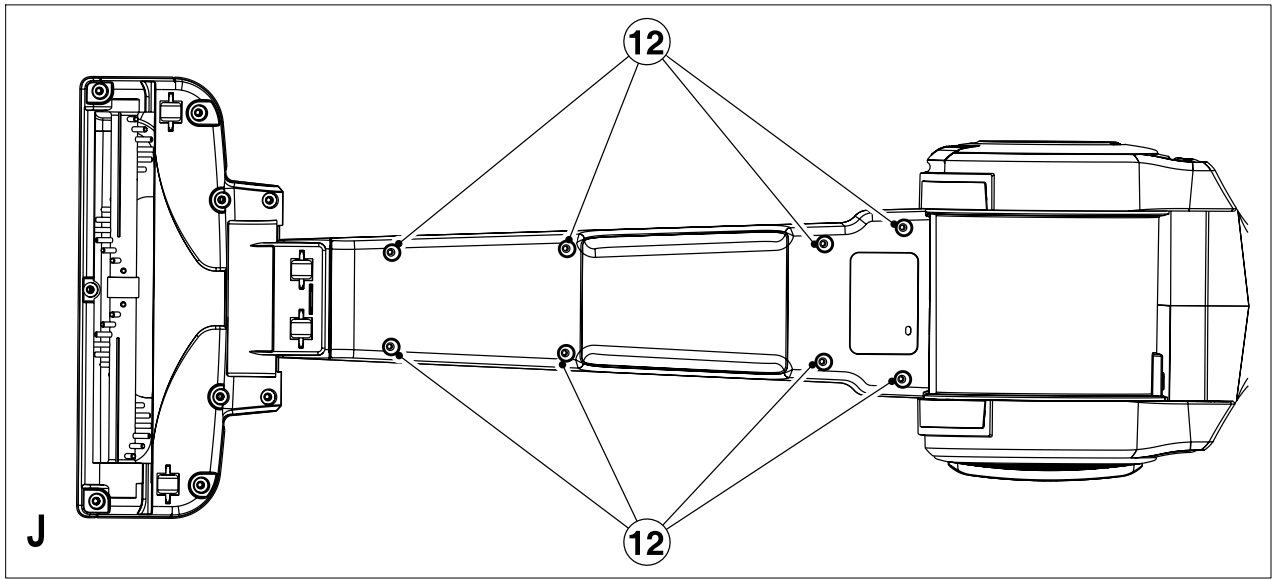

Intended use

Your Black & Decker Pivot Plus® slim vac has been designed for light dry vacuum cleaning purposes. This appliance is intended for household use only.

Safety instructions

Warning! When using battery-powered appliances, basic safety precautions, including the following, should always be followed to reduce the risk of fire, leaking batteries, personal injury and material damage.

- ◆ Read all of this manual carefully before using the appliance.
- ◆ The intended use is described in this manual. The use of any accessory or attachment or the performance of any operation with this appliance other than those recommended in this instruction manual may present a risk of personal injury.
- ◆ Retain this manual for future reference.

Using your appliance

- ◆ Do not use the appliance to pick up liquids or any materials that could catch fire.
- ◆ Do not immerse the appliance in water.
- ◆ Never pull the charger lead to disconnect the charger from the socket. Keep the charger lead away from heat, oil and sharp edges.
- ◆ This appliance is not intended for use by young or infirm persons without supervision. Children must be supervised to ensure they do not play with the appliance.

After use

- ◆ Unplug the charger before cleaning the charger or charging base.
- ◆ When not in use, the appliance should be stored in a dry place.
- ◆ Children should not have access to stored appliances.

Inspection and repairs

- ◆ Before use, check the appliance for damaged or defective parts. Check for breakage of parts, damage to switches and any other conditions that may affect its operation.
- ◆ Do not use the appliance if any part is damaged or defective.
- ◆ Have any damaged or defective parts repaired or replaced by an authorized repair agent.
- ◆ Regularly check the charger lead for damage. Replace the charger if the lead is damaged or defective.
- ◆ Never attempt to remove or replace any parts other than those specified in this manual.

Additional safety instructions for batteries and chargers

Battery and charger

- ◆ Never attempt to open for any reason.
- ◆ Do not expose the battery to water.
- ◆ Do not short circuit the charging terminals on the vacuum cleaner bowl or the charging unit.
- ◆ Do not store in locations where the temperature may exceed 40°C.
- ◆ Charge only at ambient temperatures between 10°C and 40°C.
- ◆ Do not incinerate the battery.
- ◆ When disposing of batteries, follow the instructions given in the section "Protecting the environment".
- ◆ Have defective cords replaced immediately.
- ◆ Do not expose the charging base to water.
- ◆ Do not open the charging base.
- ◆ Do not probe the charger.

Electrical safety

Your charger has been designed for a specific voltage. Always check that the mains voltage corresponds to the voltage on the rating plate. Never attempt to replace the charger unit with a regular mains plug.



The charger is intended for indoor use only.



Read the instruction manual before use.



The charger automatically shuts off if the ambient temperature becomes too high. As soon as the ambient temperature has cooled down, the charger will resume operating.



Charge only at ambient temperatures between 10°C and 40°C.



Charging.

Features

1. Pivot lock trigger
2. Dust container door
3. Release latch (for dust container door)
4. Charging base
5. Charging indicator
6. Pivoting arm
7. Beater bar/vac head
8. Maintenance access panel
9. Beater bar/vac On/Off switch

Installation

Attaching the handle to the appliance (fig. A)

- ◆ Align the D-handle with the main body of the unit and push it down until it is fully seated.
- ◆ Remove the phillips head screw from the plastic bag.
- ◆ Insert the screw (13) into the hole.
- ◆ Tighten the screw (13) using a phillips screwdriver.

Charging base (fig. B)

Place the charging base (4) on the floor, convenient to an electrical outlet. The Pivot Plus® slim vac is stored and charged in the base whenever it is not in use.

Warning! Falling/tripping hazard. Do not place the charging base on any elevated surface. The appliance is designed to be placed into and removed from the charging base when it is sitting on the floor convenient to an electrical outlet.

Use

Before first use, the battery must be charged for at least 16 hours.

- ◆ Place the appliance on the charging base (4) whenever it is not in use.

You may need to charge the appliance many times initially in order to achieve the best running time performance.

Charging the battery (fig. B)

Warning! Do not charge the battery at ambient temperatures below 10°C or above 40°C.

- ◆ Make sure that the appliance is switched off.

The battery will not be charged with the beater bar/vac on/off switch (9) in the on position.

- ◆ Place the appliance on the charging base (4) as shown.
- ◆ Plug in the charger. Switch on at the mains.

The charging indicator (5) will be lit.

- ◆ For the first charging, leave the appliance to charge for at least 16 hours.

While charging, the charger may become warm. This is normal and does not indicate a problem.

The appliance can be left connected to the charger indefinitely. The charging indicator (5) will be lit as long as the appliance is connected to the plugged-in charger.

Opening the appliance (fig B, C and D)

- ◆ To open the appliance for use, lift it from the charging base (4) (fig. B).
- ◆ Pull back the pivot lock trigger (1) on the handle and rotate the vacuum head (fig. C).
- ◆ Release the pivot lock trigger (1) to lock the appliance in any of the three different working positions a, b and c (fig. D).

Switching on and off (fig. E)

- ◆ To switch the appliance on, slide the beater bar/vac On/Off switch (9) forward to position 1 (vacuum only).
- ◆ For vacuuming with the beater bar operation, slide the switch (9) forward to position 2.
- ◆ To switch the appliance off, slide the switch (9) back to position 0.

Troubleshooting

If the product does not work, check the following:

- ◆ The charger was correctly plugged in for recharge (it feels slightly warm to the touch).
- ◆ The charger cord is not damaged and is correctly attached to the base.
- ◆ The charger is plugged into a working electrical outlet.

If the unit does not charge, check the following:

- ◆ Make sure that the beater bar/vac On/Off switch (9) is at position 0. The appliance will not charge if the appliance is switched ON.

Cleaning and maintenance

Warning! Regularly clean the filters.

Cleaning the dust container and filters (fig. F and G)

The filters are re-usable and should be cleaned regularly.

- ◆ Press the release latch (3) and open the container door (2).
- ◆ Remove the filters (10 and 11).
- ◆ Empty the dust container.
- ◆ Brush any loose dust off the filters.
- ◆ Wash the filters in warm, soapy water (fig. G).

Warning! Do not immerse the appliance in water. A damp cloth and soapy water should be used to clean the exterior of the appliance. Always make sure that the appliance is completely dry before re-use or storing.

- ◆ Make sure that the filters (10 and 11) are dry.
- ◆ Refit the filters (10 and 11).
- ◆ Close the container door (2). Make sure that the release latch (3) clicks into place.

Warning! Never use the appliance without the filters. Optimum dust collection will only be achieved with clean filters.

Maintenance access (Fig. H and I)

The maintenance access panel (8) can be removed to aid cleaning should the appliance become blocked, resulting in a loss of suction.

- ◆ Remove the maintenance access panel (8) from the pivot arm (6) using a flat bladed screwdriver (fig. I) to release the front clip features.
- ◆ Once released, the section will pivot free of the main assembly to give access for cleaning.

Replacing the filters

The filters should be replaced every 6 to 9 months and whenever worn or damaged. Replacement filters are available from your Black & Decker dealer (cat. no. FVF90):

- ◆ Remove the old filters as described above.
- ◆ Fit the new filters as described above.

Protecting the environment



Separate collection. This product must not be disposed of with normal household waste.

Should you find one day that your Black & Decker product needs replacement, or if it is of no further use to you, do not dispose of it with household waste. Make this product available for separate collection.



Separate collection of used products and packaging allows materials to be recycled and used again. Re-use of recycled materials helps prevent environmental pollution and reduces the demand for raw materials.

Local regulations may provide for separate collection of electrical products from the household, at municipal waste sites or by the retailer when you purchase a new product.

Black & Decker provides a facility for the collection and recycling of Black & Decker products once they have reached the end of their working life. To take advantage of this service please return your product to any authorised repair agent who will collect them on our behalf.

You can check the location of your nearest authorised repair agent by contacting your local Black & Decker office at the address indicated in this manual. Alternatively, a list of authorised Black & Decker repair agents and full details of our after-sales service and contacts are available on the Internet at: **www.2helpU.com**.

Batteries



Black & Decker batteries can be recharged many times. At the end of their useful life, discard batteries with due care for our environment.:

If you want to dispose of the product yourself, the battery must be removed as described below and disposed of in accordance with local regulations.

- ◆ Discharge the battery by operating the appliance until the motor stops.
- ◆ Open the appliance to get access to the eight screws (12) securing the two housing halves (fig. J).
- ◆ Remove the eight screws (12).
- ◆ Pull the cover away from the appliance.
- ◆ Disconnect the battery pack.
- ◆ Place the battery in a suitable packaging to ensure that the terminals cannot be short-circuited.
- ◆ NiHM batteries are recyclable. Take them to any authorised repair agent or a local recycling station.

Technical data

	FV1205N	FV1805N
Voltage	Vdc 12.0	18.0
Weight	kg 3.4	3.7

Charger

Input voltage	Vac 230
Approx. charging time	h 16
Weight	kg 0.6

EC declaration of conformity

FV1205N, FV1805N

Black & Decker declares that these products conform to:

2006/95/EEC, EN60335

Level of sound pressure:

<70 dB(A) according to EN 60704

The undersigned is responsible for compilation of the technical file and makes this declaration on behalf of
Black & Decker



Kevin Hewitt
Director of Consumer Engineering
Spennymoor, County Durham, DL16 6JG
United Kingdom
04-06-2008

To claim on the guarantee, you will need to submit proof of purchase to the seller or an authorised repair agent. You can check the location of your nearest authorised repair agent by contacting your local Black & Decker office at the address indicated in this manual. Alternatively, a list of authorised Black & Decker repair agents and full details of our after-sales service and contacts are available on the Internet at:

www.2helpU.com

Please visit our website **www.blackanddecker.co.uk** to register your new Black & Decker product and to be kept up to date on new products and special offers. Further information on the Black & Decker brand and our range of products is available at **www.blackanddecker.co.uk**.

Guarantee

Black & Decker is confident of the quality of its products and offers an outstanding guarantee. This guarantee statement is in addition to and in no way prejudices your statutory rights. The guarantee is valid within the territories of the Member States of the European Union and the European Free Trade Area.

If a Black & Decker product becomes defective due to faulty materials, workmanship or lack of conformity, within 24 months from the date of purchase, Black & Decker guarantees to replace defective parts, repair products subjected to fair wear and tear or replace such products to make sure of the minimum inconvenience to the customer unless:

- ◆ The product has been used for trade, professional or hire purposes.
- ◆ The product has been subjected to misuse or neglect.
- ◆ The product has sustained damage through foreign objects, substances or accidents.
- ◆ Repairs have been attempted by persons other than authorised repair agents or Black & Decker service staff.

Partial support - Only parts shown available
Nur die aufgeführten teile sind lieferbar
Reparation partielle - Seules les pieces indiquees sont disponibles
Supporto parziale - Sono disponibili soltanto le parti evidenziate
Solo estan disponibles las peizas listadas
So se encontraran disponibles as pecas listadas
Gedeeltelijke ondersteuning - alleen de getoonde onderdelen
zijn beschikbaar

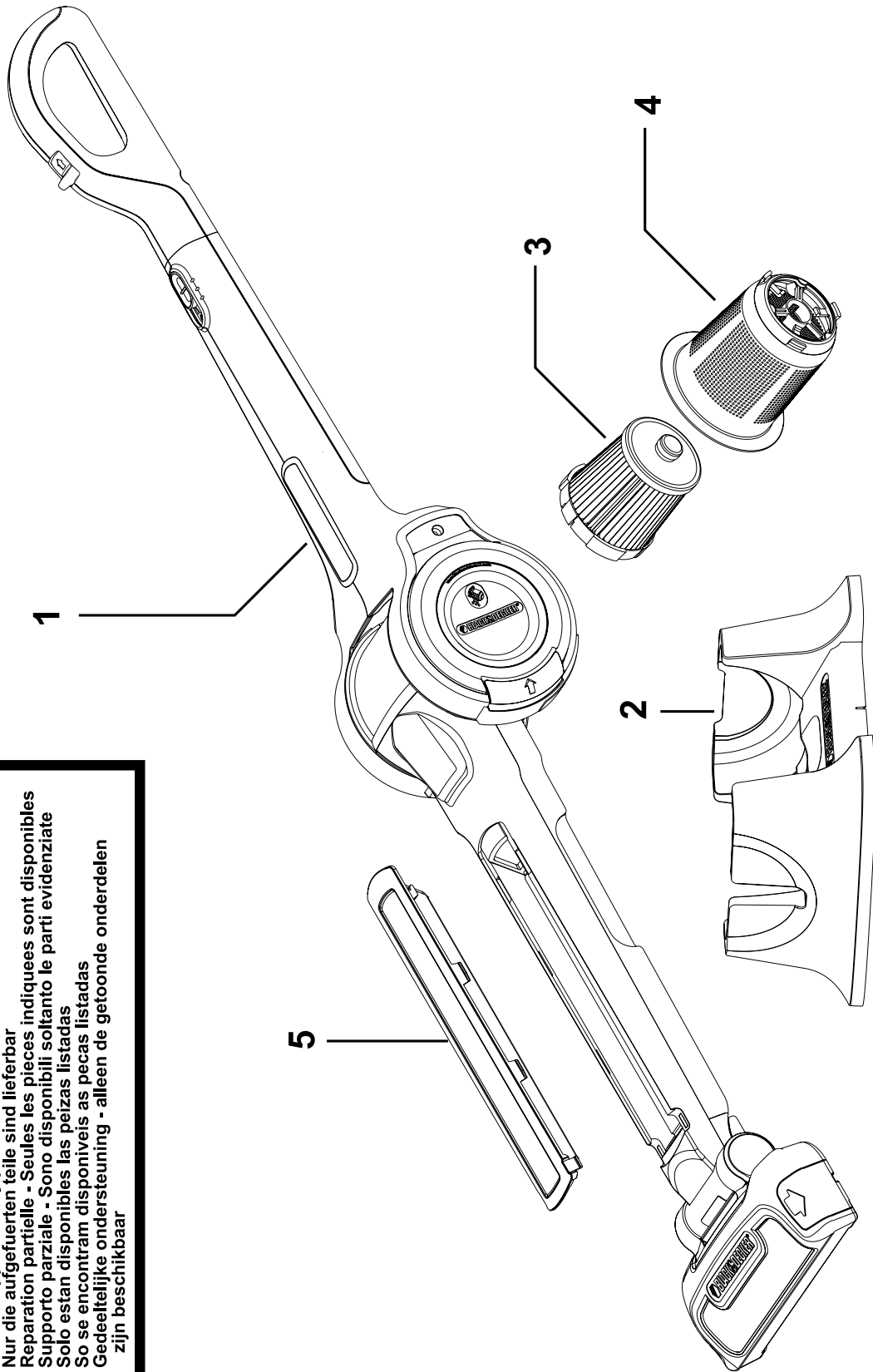

Australia

Black & Decker (Australia) Pty. Ltd.
20 Fletcher Road, Mooroolbark,
Victoria, 3138

Tel. 03-8720 5100
Fax 03-9727 5940

New Zealand

Black & Decker
5 Te Apunga Place
Mt Wellington
Auckland 1060

Tel. +64 9 259 1133
Fax +64 9 259 1122

United Kingdom

Black & Decker
210 Bath Road
Slough, Berkshire SL1 3YD

Tel. 01753 511234
Fax 01753 551155
Helpline 01753 574277