

This Owner's Manual is provided and hosted by Appliance Factory Parts.

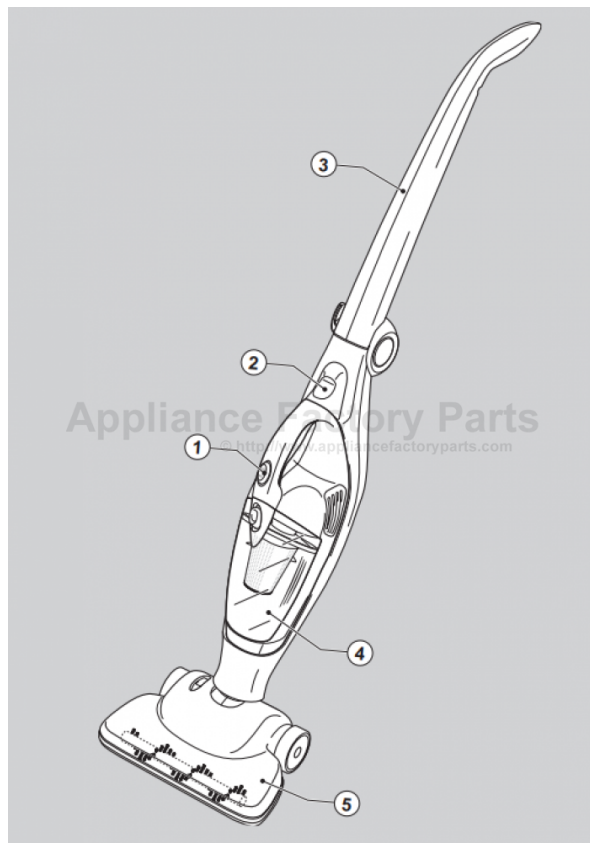

Black & Decker FV750 Owner's Manual

[Shop genuine replacement parts for Black & Decker
FV750](#)



[Find Your Black & Decker Vacuum Cleaner Parts - Select From 339 Models](#)

----- Manual continues below -----



www.blackanddecker.co.uk

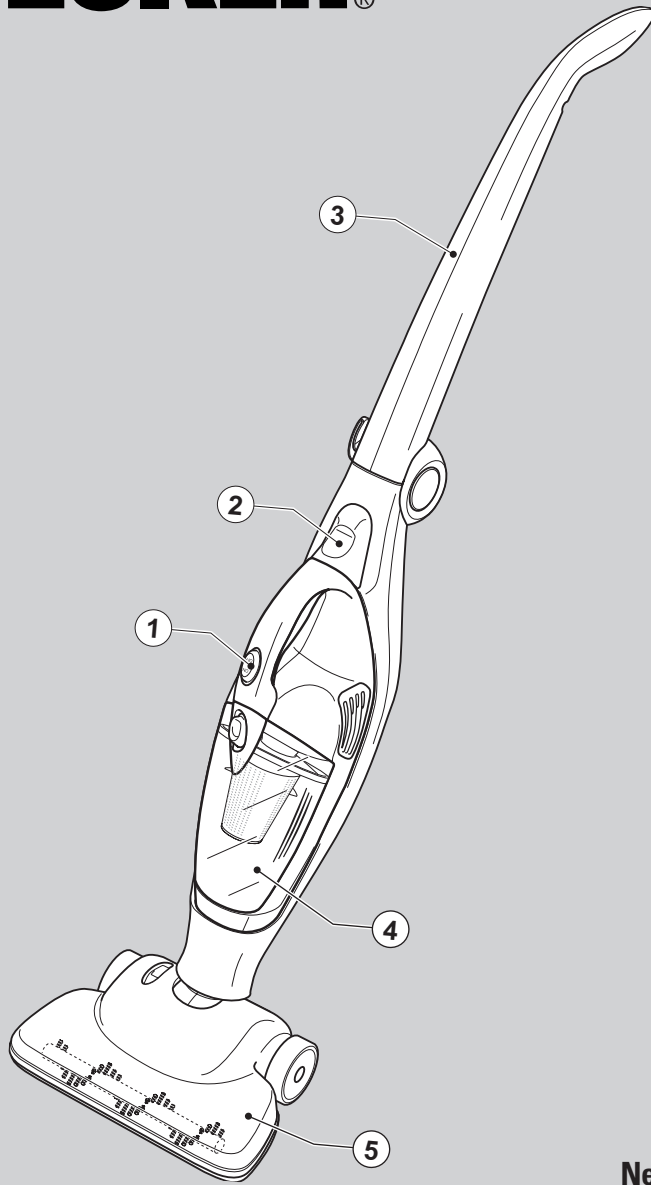

UK

Ireland

Australia

New Zealand

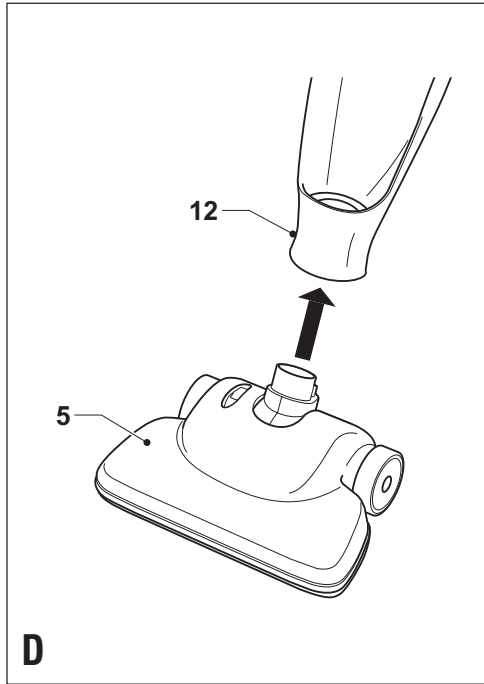
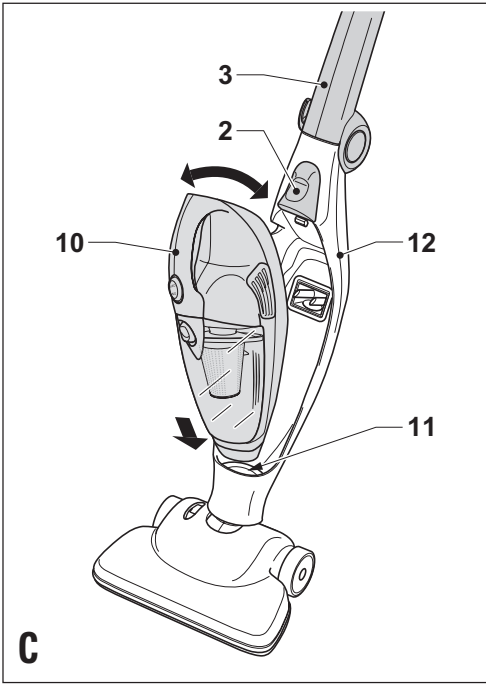
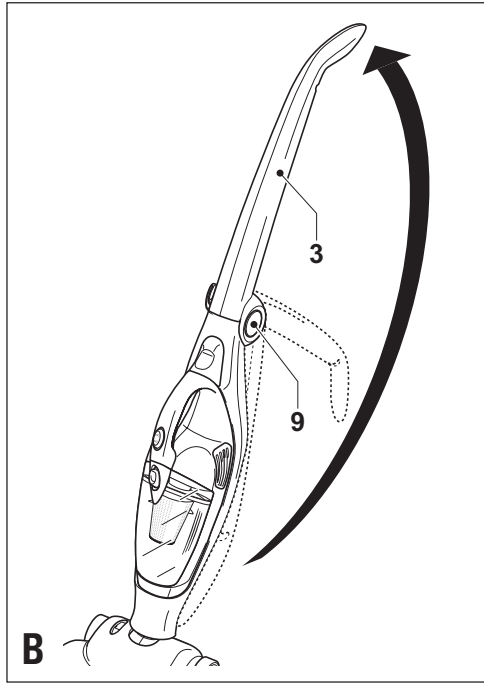
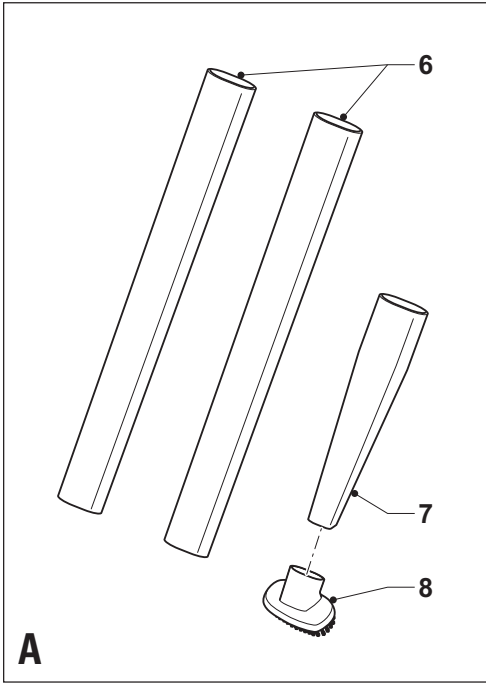

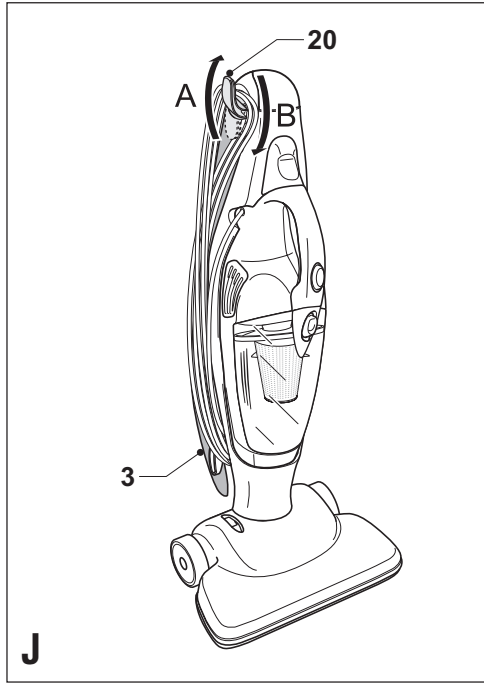
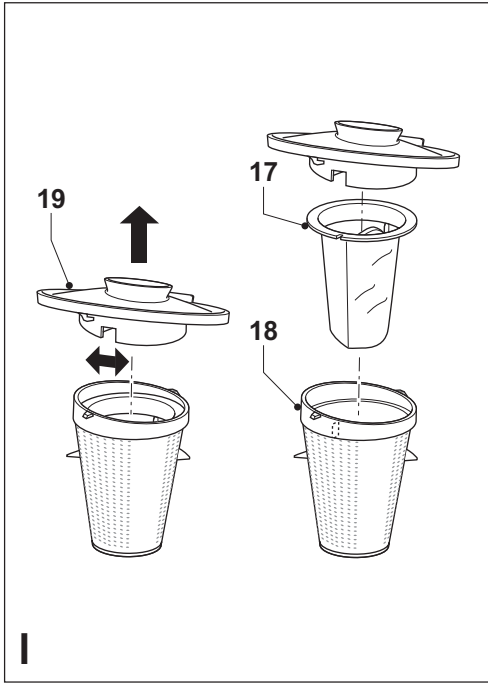

Intended use

Your Black & Decker Dustbuster® Stick Vac has been designed for light dry vacuum cleaning.

This product is intended for household use only.

Safety instructions

- ◆ **Warning!** When using mains-powered appliances, basic safety precautions, including the following, should always be followed to reduce the risk of fire, electric shock, personal injury and material damage.
- ◆ Read all of this manual carefully before using the appliance.
- ◆ The intended use is described in this manual. The use of any accessory or attachment or the performance of any operation with this appliance other than those recommended in this instruction manual may present a risk of personal injury.
- ◆ Retain this manual for future reference.

Using your appliance

- ◆ Make sure that the appliance is switched off before connecting to or disconnecting from the power supply.
- ◆ Always take care when using the appliance.
- ◆ Do not use the appliance outdoors.
- ◆ Do not leave the appliance unattended while it is connected to the power supply.
- ◆ Never pull the power supply cord to disconnect the plug from the socket. Keep the power supply cord away from heat, oil and sharp edges.
- ◆ If the power supply cord is damaged during use, disconnect the appliance from the power supply immediately. Do not touch the power supply cord before disconnecting from the power supply.
- ◆ Disconnect the appliance from the power supply when not in use, before fitting or removing parts and before cleaning.

Safety of others

- ◆ Do not allow children or any person unfamiliar with these instructions to use the appliance.
- ◆ Do not allow children or animals to come near the work area or to touch the appliance or power supply cord. Close supervision is necessary when the appliance is used near children.

After use

- ◆ Switch off and remove the plug from the socket before leaving the appliance unattended and before changing, cleaning or inspecting any parts of the appliance.
- ◆ When not in use, the appliance should be stored in a dry place. Children should not have access to stored appliances.

Inspection and repairs

- ◆ Before use, check the appliance for damaged or defective parts. Check for breakage of parts, damage to switches and any other conditions that may affect its operation.
- ◆ Do not use the appliance if any part is damaged or defective.
- ◆ Have any damaged or defective parts repaired or replaced by an authorised repair agent.
- ◆ Before use, check the power supply cord for signs of damage, ageing and wear.
- ◆ Do not use the appliance if the power supply cord or mains plug is damaged or defective.
- ◆ If the power supply cord or mains plug is damaged or defective it must be repaired by an authorised repair agent in order to avoid a hazard. Do not cut the power supply cord and do not attempt to repair it yourself.
- ◆ Never attempt to remove or replace any parts other than those specified in this manual.

Double insulation



This appliance is double insulated; therefore no earth wire is required. Always check that the power supply corresponds to the voltage on the rating plate.

Additional safety instructions for vacuum cleaners

- ◆ Do not use the appliance to pick up hot objects
- ◆ Do not use the appliance to pick up liquids.
- ◆ Do not use the appliance to pick up any materials that could catch fire.
- ◆ Do not use the appliance near water.
- ◆ Do not immerse the appliance in water or any other liquid.
- ◆ Keep the motor draught away from your eyes and face.
- ◆ Keep your hair, clothing and gloves away from moving parts.
- ◆ Use caution when using the appliance at the top of stairs or near children.
- ◆ Always work from bottom up when using the appliance on stairs.
- ◆ Always route the cord carefully to avoid a tripping hazard
- ◆ Keep children and animals at a safe distance when using this appliance.
- ◆ Do not use the appliance to vacuum any electrical appliances while they are plugged in.
- ◆ Do not use the appliance to pick up sharp objects that could damage the filter or other parts.
- ◆ Do not use the appliance without the dust bowl or filters in place.

Features

1. On/off switch
2. Release button
3. Handle
4. Dust bowl
5. Suction head

Fig. A

6. Extension tubes
7. Crevice tool
8. Brush tool

Assembly

Warning! Make sure that the appliance is switched off and unplugged.

Raising and folding the handle (fig. B)

Raising

- ◆ Press the release button (9).
- ◆ Raise the handle until it clicks into place.

Folding

- ◆ Press the release button (9).
- ◆ Lower the handle until it clicks into place.

Fitting and removing the hand-held vacuum cleaner (fig. C)

Fitting

- ◆ Position the front (10) of the appliance in the lower part (11) of the base.
- ◆ Push the back end of the appliance down into the base (12) until a click is heard.

Removing

- ◆ Hold the appliance at the handle.
- ◆ Keep the release button (2) depressed.
- ◆ Pull out the back end of the appliance.
- ◆ Lift the appliance off the base.

Fitting the suction head (fig. D)

- ◆ Slide the head (5) into the nozzle of the base (12).
- ◆ To remove the head, pull it off the base.

Fitting the accessories (fig. E)

The accessories provided can be used in various combinations, depending on the task:

- General vacuuming / dusting (7 & 8)
- Vacuuming in confined spaces (7)

To fit an accessory, proceed as follows:

- ◆ Remove the appliance from the base.
- ◆ Insert the appropriate accessory into the front of the appliance.
- ◆ If necessary, fit the required number of tubes (6) between the appliance and the accessory to extend the working height.

Use

Warning! Before connecting to the power supply, make sure that the appliance is switched off.

Switching on and off

- ◆ To switch the appliance on, slide the on/off switch (1) forward.
- ◆ To switch the appliance off, slide the on/off switch backward.

Warning! Make sure the accessories are securely attached before switching on. Keep a firm grip on the appliance when switching on and during use.

Operating the appliance

The appliance can be used either with the long handle as an upright vacuum cleaner or without the long handle as a hand-held vacuum cleaner:

Operating as an upright vacuum cleaner (fig. F & G)

The upright vacuum cleaner is used for vacuuming hard floors, carpets and rugs.

- ◆ Raise the handle (3).
- ◆ Clip the cable end leading to the appliance into the cable restraint (13).
- ◆ Switch the appliance on.
- ◆ If the appliance is locked in the upright position by the suction head, hold the head in place with your foot and pull at the handle until the head dislocates.

The brush roller (14) is needed when cleaning rugs and carpets.

- ◆ To switch on the brush roller, press the button (15).
- ◆ To switch off the brush roller, press the button (15) again.

Operating as a hand-held vacuum cleaner

The hand-held vacuum cleaner is for use on upholstery and in confined spaces.

- ◆ Remove the hand-held vacuum cleaner from the base.
- ◆ If necessary, fit the required accessory.
- ◆ Switch the appliance on.

Thermal safeguard

The motor of the appliance is fitted with a thermal safeguard. This device automatically switches the appliance off in case of overheating. If this occurs, proceed as follows:

- ◆ Switch the appliance off and remove the plug from the wall socket.
- ◆ Allow the unit to cool. When the unit has cooled down, empty the dust bowl and clean the filter.
- ◆ Re-insert the plug in the wall socket and switch the appliance on.

Emptying the dust bowl (fig. H & I)

When the dust bowl is full or the filter is clogged, the bowl should be emptied. Always empty the dust bowl into a waste bin outdoors.

FV750

- ◆ Release the bowl (4) by pushing the button (16) forward. While keeping the button in forward position remove the bowl from the appliance.
- ◆ Take the filter (17) out of the dust bowl.
- ◆ Empty the dust bowl.
- ◆ Refit the filter.
- ◆ Refit the dust bowl into the appliance. Make sure the dust bowl clicks into place.

FV850

- ◆ Release the bowl (4) by pushing the button (16) forward. While keeping the button in forward position remove the bowl from the appliance.
- ◆ Take the filter holder (18) out of the dust bowl.
- ◆ Empty the dust bowl.
- ◆ Open the cover (19) as shown (fig. I).
- ◆ Pull the filter (17) out of the filter holder (19).
- ◆ Refit the filter.
- ◆ Refit the cover
- ◆ Refit the dust bowl into the appliance. Make sure the dust bowl clicks into place.

Cleaning, maintenance and storage

Your tool has been designed to operate over a long period of time with a minimum of maintenance. Continuous satisfactory operation depends upon proper tool care and regular cleaning.

- ◆ Frequently clean the filter to avoid overheating.
- ◆ Regularly clean the ventilation slots in your tool using a soft brush.
- ◆ Regularly clean the motor housing using a damp cloth. Do not use any abrasive or solvent-based cleaner.

Cleaning the dust bowl and the filter (fig. H & I)

The filter is reusable and should be cleaned frequently. It should be replaced when it is worn or damaged.

- ◆ Empty the dust bowl as described above.
- ◆ Brush any loose dust off the filter (17).
- ◆ Wash the filter and the dust bowl in warm, soapy water.
- ◆ Make sure that the dust bowl and the filter are completely dry.
- ◆ Refit the filter.
- ◆ Refit the dust bowl into the appliance. Make sure the dust bowl clicks into place.

FV850 - Replacing the HEPA filter (fig. I)

The HEPA filter reduces the amount of dust exiting the motor housing to a minimum. The filter should be replaced whenever worn or damaged. Replacement filters are available from your Black & Decker dealer.

- ◆ Empty the dust bowl as described above.
- ◆ Open the cover (19).
- ◆ Remove the old filter (17).
- ◆ Insert the new filter as shown.
- ◆ Refit the cover.
- ◆ Refit the dust bowl into the appliance. Make sure the dust bowl clicks into place.

Storing the appliance (fig. J)

- ◆ Place the appliance in an upright position.
 - ◆ Fold the handle (3).
 - ◆ Set the hook (20) to the up position (A).
 - ◆ Wind the cord around the upper and the lower hook.
- To release the cord:
- ◆ Set the hook (18) to the down position (B) or raise the handle.

Mains plug replacement (U.K. & Ireland only)

If a new mains plug needs to be fitted:

- ◆ Safely dispose of the old plug.
- ◆ Connect the brown lead to the live terminal in the new plug.
- ◆ Connect the blue lead to the neutral terminal.

Warning! No connection is to be made to the earth terminal. Follow the fitting instructions supplied with good quality plugs. Recommended fuse: 5 A.

Protecting the environment



Separate collection. This product must not be disposed of with normal household waste.

Should you find one day that your Black & Decker product needs replacement, or if it is of no further use to you, do not dispose of it with household waste. Make this product available for separate collection.



Separate collection of used products and packaging allows materials to be recycled and used again. Re-use of recycled materials helps prevent environmental pollution and reduces the demand for raw materials.

Local regulations may provide for separate collection of electrical products from the household, at municipal waste sites or by the retailer when you purchase a new product.

Black & Decker provides a facility for the collection and recycling of Black & Decker products once they have reached the end of their working life. To take advantage of this service please return your product to any authorised repair agent who will collect them on our behalf.

You can check the location of your nearest authorised repair agent by contacting your local Black & Decker office at the address indicated in this manual. Alternatively, a list of authorised Black & Decker repair agents and full details of our after-sales service and contacts are available on the Internet at: www.2helpU.com

Technical data

		FV750	FV850
Voltage	V _{AC}	230	230
Power input	W	750	850
Weight	kg	3.6	3.6

EC declaration of conformity

FV750/FV850

Black & Decker declares that these products conform to:
89/336/EEC, 73/23/EEC, EN 50144, EN 55014



Kevin Hewitt
Director of Consumer Engineering
Spennymoor, County Durham DL16 6JG,
United Kingdom
1-10-2004

Guarantee

Black & Decker is confident of the quality of its products and offers an outstanding guarantee. This guarantee statement is in addition to and in no way prejudices your statutory rights. The guarantee is valid within the territories of the Member States of the European Union and the European Free Trade Area.

If a Black & Decker product becomes defective due to faulty materials, workmanship or lack of conformity, within 24 months from the date of purchase, Black & Decker guarantees to replace defective parts, repair products subjected to fair wear and tear or replace such products to ensure minimum inconvenience to the customer unless:

- ◆ The product has been used for trade, professional or hire purposes;
- ◆ The product has been subjected to misuse or neglect;
- ◆ The product has sustained damage through foreign objects, substances or accidents;
- ◆ Repairs have been attempted by persons other than authorised repair agents or Black & Decker service staff.

To claim on the guarantee, you will need to submit proof of purchase to the seller or an authorised repair agent. You can check the location of your nearest authorised repair agent by contacting your local Black & Decker office at the address indicated in this manual. Alternatively, a list of authorised Black & Decker repair agents and full details of our after-sales service and contacts are available on the Internet at: www.2helpU.com

Please visit our website www.blackanddecker.co.uk to register your new Black & Decker product and to be kept up to date on new products and special offers. Further information on the Black & Decker brand and our range of products is available at www.blackanddecker.co.uk

Australia

Black & Decker (Australia) Pty. Ltd. Tel. 03-8720 5100
20 Fletcher Road, Mooroolbark, Fax 03-9727 5940
Victoria, 3138

New Zealand

Black & Decker Tel. 09 579 7600
81 Hugo Johnston Drive Fax 09 579 8200
Penrose, Auckland, New Zealand

United Kingdom

Black & Decker Tel. 01753 511234
210 Bath Road Fax 01753 551155
Slough, Berkshire SL1 3YD Helpline 01753 574277