

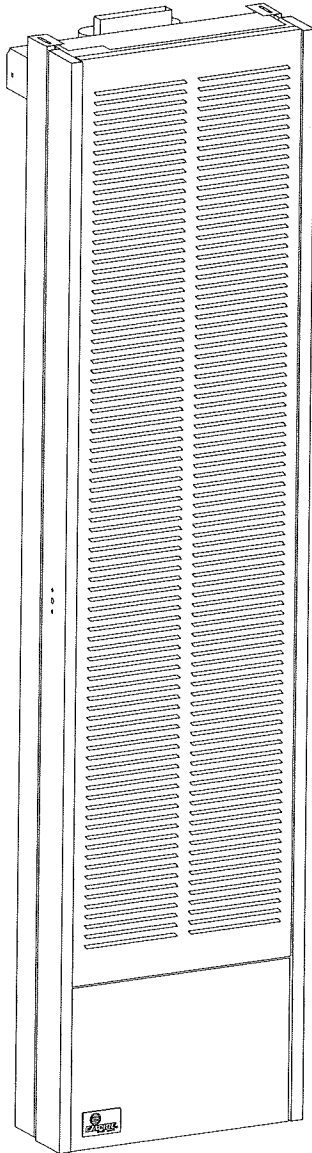

# INSTALLATION INSTRUCTIONS AND OWNER'S MANUAL



Patent Pending

## GRAVITY VENTED WALL FURNACE

### MODELS

GWT-25-1(SG, RB)

GWT-35-1(SG, RB)



EFFECTIVE DATE  
JANUARY, 1999

**WARNING:** If the information in this manual is not followed exactly, a fire or explosion may result causing property damage, personal injury or loss of life.

- Do not store or use gasoline or other flammable vapors and liquids in the vicinity of this or any other appliance.
- **WHAT TO DO IF YOU SMELL GAS**
  - Do not try to light any appliance.
  - Do not touch any electrical switch; do not use any phone in your building.
  - Immediately call your gas supplier from a neighbor's phone. Follow the gas supplier's instructions.
  - If you cannot reach your gas supplier, call the fire department.
- Installation and service must be performed by a qualified installer, service agency or the gas supplier.

**WARNING:** If not installed, operated and maintained in accordance with the manufacturer's instructions, this product could expose you to substances in fuel or from fuel combustion which can cause death or serious illness.

## Introduction

Vented wall furnace is shipped ready to install in a 2" x 4" stud wall, with studs 16" (406mm) center to center. Always consult your local Building Department regarding regulations, codes or ordinances which apply to the installation of a vented wall furnace.

## Instructions to Installer

1. Installer must leave instruction manual with owner after installation.
2. Installer must have owner fill out and mail warranty card supplied with furnace.
3. Installer should show owner how to start and operate furnace and thermostat.

### Warning:

**Any change to this furnace or its control can be dangerous. This is a heating appliance and any panel, door or guard removed for servicing an appliance must be replaced prior to operating the appliance.**

## General Information

This series is design certified in accordance with American National Standard / CSA Standard Z21.86b-1998 and CSA 2.32b-M98 by the American Gas Association and Canadian Gas Association, as a Vented Wall Furnace and must be installed according to these instructions.

**Any alteration of the original design, installed other than as shown in these instructions or use with a type of gas not shown on the rating plate is the responsibility of the person and company making the change.**

## Important

All correspondence should refer to complete Model No., Serial No. and type of gas.

**Notice:** During initial firing of this furnace, its paint will bake out and smoke will occur. To prevent triggering of smoke alarms, ventilate the room in which the furnace is installed.

## Installation in Residential Garages

Gas utilization equipment in residential garages shall be installed so that all burners and burner ignition devices are located not less than 18" (457mm) above the floor.

Such equipment shall be located, or protected, so it is not subject to physical damage by a moving vehicle.

## Specifications

Model	GWT-25	GWT-35
Input BTU/HR(KW/H)	25,000 (7.3)	35,000 (10.3)
Height	66 1/8" (168cm)	66 1/8" (168cm)
Width	16" (406mm)	16" (406mm)
Depth	6" (152mm)	6" (152mm)
Gas Inlet Pipe	1/2"	1/2"
Vent Pipe Type B Oval	4" (102mm)	4" (102mm)
<b>Accessories For Above Furnaces</b>		
Blower Kit		GWTB-1
Rear Register Kit		GWTR-1
Out-of-the-Wall Kit		GWTW-1

**Attention:** When the GWTW-1, Out-of-the-Wall kit is used the GWTR-1, Rear Register kit **cannot** be used.

## Qualified Installing Agency

Installation and replacement of gas piping, gas utilization equipment or accessories and repair and servicing of equipment shall be performed only by a qualified agency. The term "qualified agency" means any individual, firm, corporation or company which either in person or through a representative is engaged in and is responsible for (a) the installation or replacement of gas piping or (b) the connection, installation, repair or servicing of equipment, who is experienced in such work, familiar with all precautions required and has complied with all the requirements of the authority having jurisdiction.

The installation must conform to local codes or, in the absence of local codes, with the *National Fuel Gas Code ANSI Z223.1\*/Canadian Installation Code, CAN/CGA B149.*

\*Available from the American National Standards Institute, Inc., 11 West 42nd St., New York, N.Y. 10036.

## THIS IS A HEATING APPLIANCE

DO NOT OPERATE THIS APPLIANCE WITHOUT OUTER CASING INSTALLED.

- Due to high temperatures the appliance should be located out of traffic and away from furniture and draperies.
- Children and adults should be alerted to the hazards of high surface temperatures and should stay away to avoid burns or clothing ignition.
- Young children should be carefully supervised when they are in the same room as the appliance.
- Clothing or other flammable material should not be placed on or near the appliance.
- Any safety screen or guard removed for servicing an appliance must be replaced prior to operating the appliance.
- Keep burner and control compartment clean.
- Installation and repair should be done by a QUALIFIED SERVICE PERSON. The appliance should be inspected before use and at least annually by a qualified service person. More frequent cleaning may be required due to excessive lint from carpeting, bedding materials, etc. It is imperative that control compartments, burners and circulating air passageways of the appliance be kept clean.
- DO NOT put anything around the furnace that will obstruct the flow of combustion and ventilation air.
- DO keep the appliance area clear and free from combustible material, gasoline and other flammable vapors and liquids.
- DO examine venting system periodically and replace damaged parts.
- DO make a periodic visual check of pilot and burners. Clean and replace damaged parts.
- DO NOT use this heater if any part has been under water. Immediately call a qualified service technician to inspect the heater and to replace any part of the control system and any gas control which has been under water.
- This furnace must not be connected to a chimney flue serving a separate solid-fuel burning appliance.

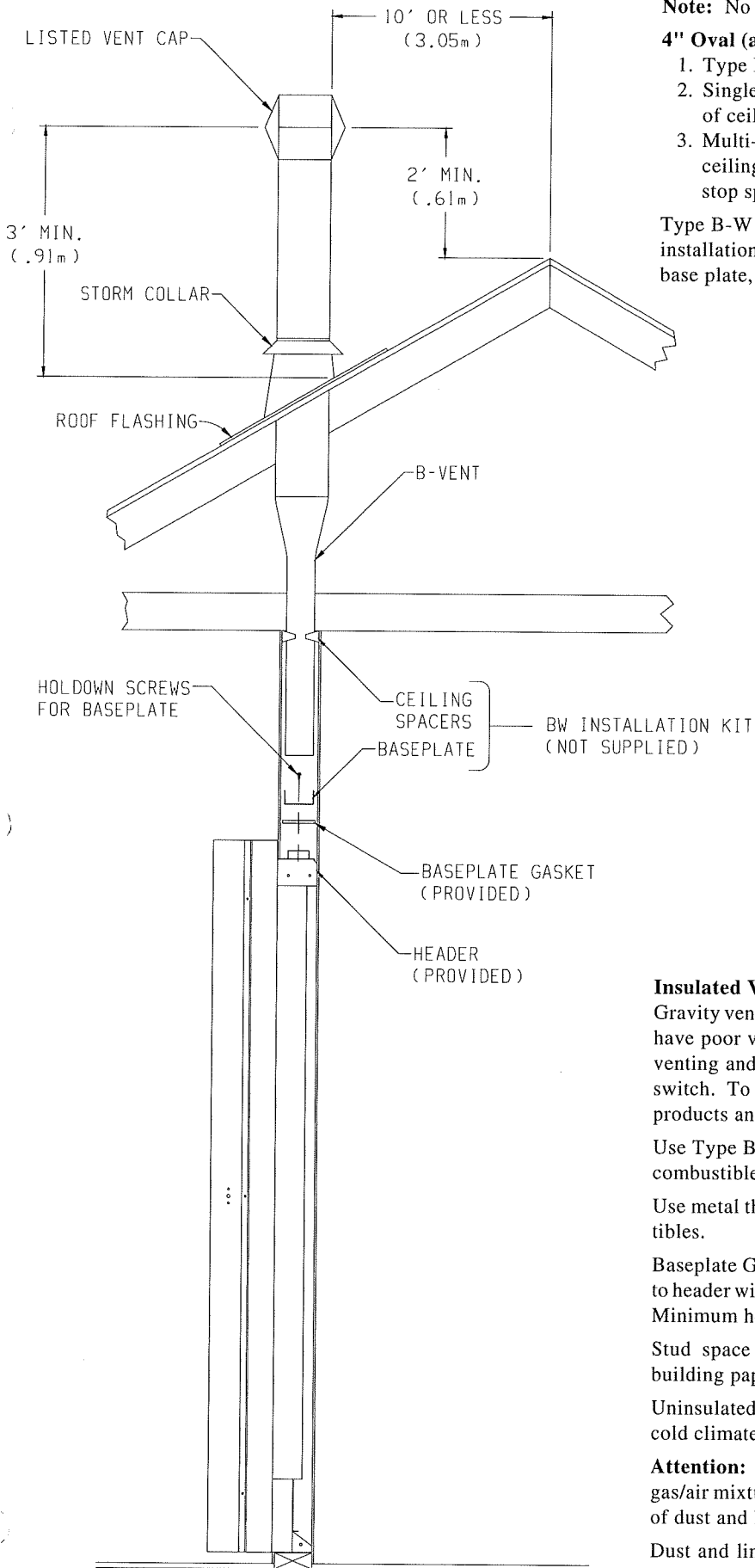

**Note:** No vent equipment supplied with furnace.

**4" Oval (all parts purchase locally)**

1. Type B-1 oval pipe
2. Single story type B-1 gas vents require a baseplate and one pair of ceiling plate spacers.
3. Multi-story type B-1 gas vents require a baseplate, one pair of ceiling plate spacers at the first floor ceiling and one pair of fire stop spacers at each successive ceiling level.

Type B-W gas vent pipe is available for single story or multi-story installations. Type B-W gas vent pipe is to be used with the Listed base plate, ceiling plate spacers and fire stop spacers.

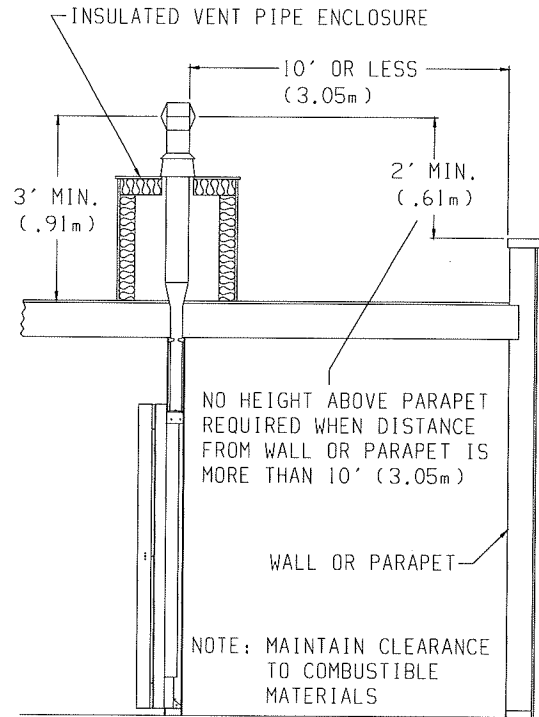

**Insulated Vent Enclosure**

Gravity vented wall furnaces installed in buildings with flat roofs can have poor venting. The cold vent pipe will have a delay in proper venting and cause the wall furnace to shut "off" by the vent safety switch. To prevent delayed venting as well as condensation of flue products an insulated vent enclosure is recommended.

Use Type B vent pipe and maintain at least a one inch clearance to combustibles.

Use metal thimble to protect vent pipe as it passes through combustibles.

Baseplate Gasket is factory installed on header. Baseplate attaches to header with screws. B-vent snaps into and is attached to baseplate. Minimum height of vent pipe must be six feet above header.

Stud space around gas vents must be free of obstructions and building paper.

Uninsulated Single-Wall Metal Pipe shall not be used outdoors in cold climates for venting gas utilization equipment.

**Attention:** The main burner uses room air for combustion. As the gas/air mixture is injected into the main burner, there is also the flow of dust and lint particles into the main burner.

Dust and lint accumulation inside the main burner will result in a yellow main burner flame and possible sooting inside the combustion chamber and vent pipe. To clean main burner refer to Page 8, "Proper Main Burner Flame."

## SAFETY INFORMATION FOR USERS OF LP-GAS

Propane (LP-Gas) is a flammable gas which can cause fires and explosions. In its natural state, propane is odorless and colorless. You may not know all the following safety precautions which can protect both you and your family from an accident. Read them carefully now, then review them point

by point with the members of your household. Someday when there may not be a minute to lose, everyone's safety will depend on knowing exactly what to do. If, after reading the following information, you feel you still need more information, please contact your gas supplier.

### LP-GAS WARNING ODOR

If a gas leak happens, you should be able to smell the gas because of the odorant put in the LP-Gas. That's your signal to go into immediate action!

- Do not operate electric switches, light matches, use your phone. Do not do anything that could ignite the gas.
- Get everyone out of the building, vehicle, trailer, or area. Do that IMMEDIATELY.
- Close all gas tank or cylinder supply valves.
- LP-Gas is heavier than air and may settle in low areas such as basements. When you have reason to suspect a gas leak, keep out of basements and other low areas. Stay out until firefighters declare them to be safe.
- Use your neighbor's phone and call a trained LP-Gas service person and the fire department. Even though you may not continue to smell gas, do not turn on the gas again. Do not re-enter the building, vehicle, trailer, or area.
- **Finally**, let the service man and firefighters check for escaped gas. Have them air out the area before you return. Properly trained LP-Gas service people should repair the leak, then check and relight the gas appliance for you.

### NO ODOR DETECTED - ODOR FADE

Some people cannot smell well. Some people cannot smell the odor of the chemical stench put into the gas. You must find out if you can smell the odorant in propane. Smoking can decrease your ability to smell. Being around an odor for a time can affect your sensitivity or ability to detect that odor. Sometimes other odors in the area mask the gas odor. People may not smell the gas odor or their minds are on something else. Thinking about smelling a gas odor can make it easier to smell.

The odorant in LP-gas is colorless, and it can fade under some circumstances. For example, if there is an underground leak, the movement of the gas through soil can filter the odorant. Odorants in LP-Gas also are subject to oxidation. This fading

can occur if there is rust inside the storage tank or in iron gas pipes.

The odorant in escaped gas can adsorb or absorb onto or into walls, masonry and other materials and fabrics in a room. That will take some of the odorant out of the gas, reducing its odor intensity.

LP-Gas may stratify in a closed area, and the odor intensity could vary at different levels. Since it is heavier than air, there may be more odor at lower levels. Always be sensitive to the slightest gas odor. If you detect any odor, treat it as a serious leak. Immediately go into action as instructed earlier.

### SOME POINTS TO REMEMBER

- **Learn to recognize the odor of LP-gas.** Your local LP-Gas Dealer can give you a "Scratch and Sniff" pamphlet. Use it to find out what the propane odor smells like. If you suspect that your LP-Gas has a weak or abnormal odor, call your LP-Gas Dealer.
- If you are not qualified, do not light pilot lights, perform service, or make adjustments to appliances on the LP-Gas system. If you are qualified, consciously think about the odor of LP-Gas prior to and while lighting pilot lights or performing service or making adjustments.
- Sometimes a basement or a closed-up house has a musty smell that can cover up the LP-Gas odor. Do not try to light pilot lights, perform service, or make adjustments in an area where the conditions are such that you may not detect the odor if there has been a leak of LP-Gas.
- Odor fade, due to oxidation by rust or adsorption on walls of new cylinders and tanks, is possible. Therefore, people should be particularly alert and careful when new tanks or cylinders are placed in service. Odor fade can occur in new tanks, or reinstalled old tanks, if they are filled and allowed to set too long before refilling. Cylinders and tanks which have been out of service for a time may develop internal rust which will cause odor fade. If such conditions are suspected to exist, a periodic sniff test of the gas is advisable. **If you have any question about the gas odor, call your LP-gas dealer. A periodic sniff test of the LP-gas is a good safety measure under any condition.**
- If, at any time, you do not smell the LP-Gas odorant and you think you should, assume you have a leak. Then take the same immediate action recommended above for the occasion when you do detect the odorized LP-Gas.
- If you experience a complete "gas out," (the container is under no vapor pressure), turn the tank valve off immediately. If the container valve is left on, the container may draw in some air through openings such as pilot light orifices. If this occurs, some new internal rusting could occur. If the valve is left open, then treat the container as a new tank. Always be sure your container is under vapor pressure by turning it off at the container before it goes completely empty or having it refilled before it is completely empty.

## Ventilation and Combustion Air

Wall furnaces shall be installed in a location in which the facilities for ventilation permit satisfactory combustion of gas and proper venting under normal conditions. In buildings of conventional frame, brick, or stone construction without tight storm windows and doors, infiltration is normally adequate to provide air for combustion and draft hood dilution.

Where appliances are installed in confined and unconfined spaces within a building, the building being of unusually tight construction, air for combustion and ventilation must be obtained directly from outdoors or from such spaces that freely communicate with the outdoors. Under these conditions, the confined and unconfined spaces shall be provided with two permanent openings, one near the top of the enclosure and one near the bottom; each opening shall have a free area of not less than one square inch (6.45cm<sup>2</sup>) per 2,000 BTU (.6KW/H) per hour of total input.

## Clearances

1. In selecting a location for installation, it is necessary to provide adequate accessibility clearances for servicing and proper installation.
2. Clearances to combustible surfaces are 4" (102mm) from sides, 12" (305mm) to top, 1 1/2" (38mm) from floor.

**NOTE:** Minimum distance of 1 1/2" (38mm) must also be maintained from top surface of carpeting, tile, etc.

## LOCATION - ALL MODELS

Select a location near the center of the space to be heated. Overflow heat will circulate through doorways into adjacent rooms.

For large homes or spread-out floor plans, two or more furnaces are recommended. Do not locate furnace where a door could swing over the outer casing, or where circulation could be retarded by furniture or cabinets.

Do not install in a closet, alcove or small hallway where the furnace could be isolated by closing doors to the heated space.

When location is selected, check the walls, attic and roof to make sure there are no obstructions such as pipes, electric wiring, etc., which would interfere with the installation of the furnace or vent pipe.

**NOTE:** If rear Register Kit is to be used, see Rear Register Kit instructions for location of hole in rear wall. Register outlet must be cut in wall before furnace is installed.

**NOTE:** If Optional Blower is to be used, hard wiring must be completed for the optional blower prior to installation of header plate.

## ROUGH-IN INSTRUCTIONS

### Header Plate and Vent Pipe (Figure 1 and Figure 2)

Provide an opening in the wall 14 1/2" (368mm) wide and 66 1/8" (168cm) high measured from top of floor plate (See Figure 1 and Figure 2). Wall depth is to be 2" x 4" framing with 1/4" (6.5mm) to 5/8" (16mm) sheathing. Attach baseplate (not supplied with furnace) to header plate with sheet metal screws at each end. Attach 4" (102mm) oval, double wall vent pipe to baseplate. Attach enough vent pipe so that when installed in wall opening the vent pipe will extend above the ceiling plate by at least 6" (152mm). Install ceiling spacers according to manufacturer's instructions. Insert header plate with attached 4" oval, double wall vent pipe into wall opening. Position header plate at height shown in Figure 1. Locate rear edge of nailing flange at the back of the 2" x 4" stud which will center the vent collar in the wall. Locate the angled edge of header plate flush with the top of the wall opening. Nail header plate to the wall studs.

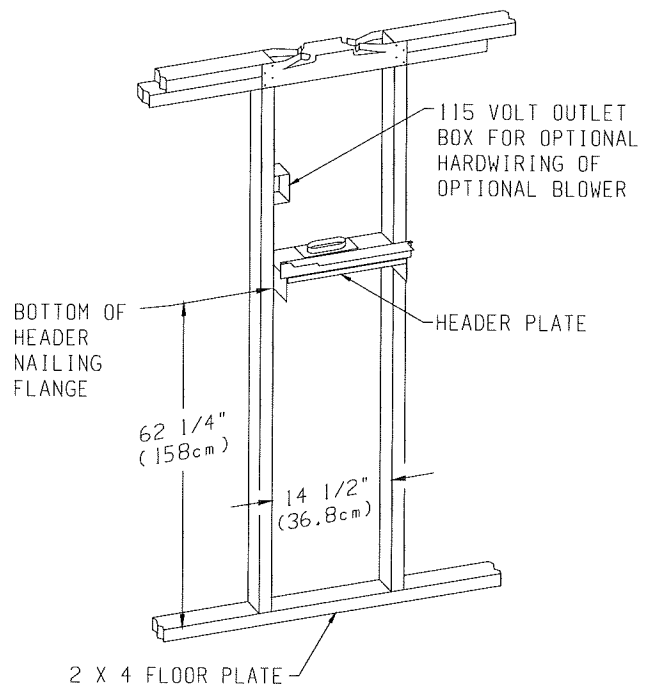

Figure 1

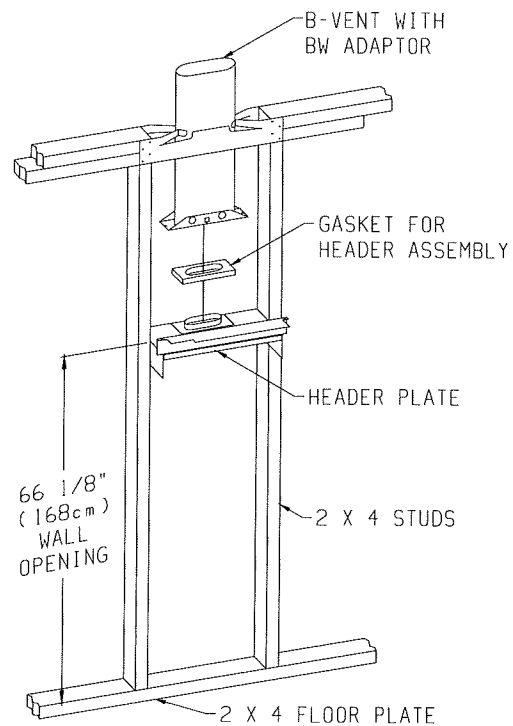

Figure 2

## Gas Supply

Check all local codes for requirements, especially for the size and type of gas supply line required. On Natural gas lines less than 15' (4.57m) long, use 1/2" pipe; on longer runs, use 3/4" iron pipe or equal. On LP gas lines please consult LP gas supplier.

## Installing a New Main Gas Cock

Each appliance should have its own manual gas cock.

A manual main gas cock should be located in the vicinity of the unit. Where none exists, or where its size or location is not adequate, contact your local authorized installer for installation or relocation.

Compounds used on threaded joints of gas piping shall be resistant to the action of liquefied petroleum gases. The gas lines must be checked for leaks by the installer. This should be done with a soap solution watching for bubbles on all exposed connections, and if unexposed, a pressure test should be made.

**Never use an exposed flame to check for leaks. Appliance must be disconnected from piping at inlet of control valve and pipe capped or plugged for pressure test. Never pressure test with appliance connected; control valve will sustain damage!**

A gas valve and ground joint union should be installed in the gas line upstream of the gas control to aid in servicing. It is required by the National Fuel Gas Code that a drip line be installed near the gas inlet. This should consist of a vertical length of pipe tee connected into the gas line that is capped on the bottom in which condensation and foreign particles may collect.

#### Method of Installing a Tee Fitting Sediment Trap (Figure 3)

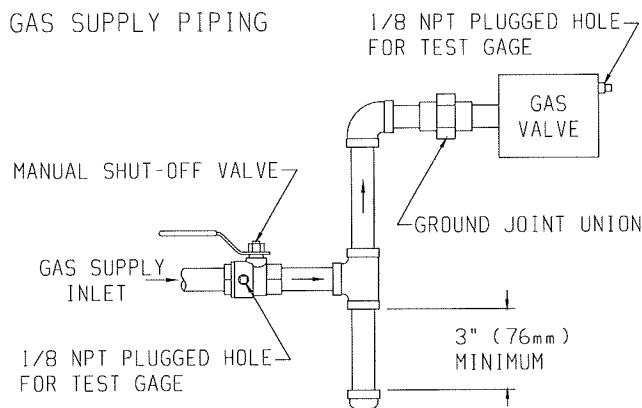

Figure 3

The use of the following gas connectors is recommended:

- ANS Z21.24 Appliance Connectors of Corrugated Metal Tubing and Fittings
- ANS Z21.45 Assembled Flexible Appliance Connectors of Other Than All-Metal Construction

The above connectors may be used if acceptable by the authority having jurisdiction.

#### Pressure Testing of the Gas Supply System

1. To check the inlet pressure to the gas valve, a 1/8" (3.175mm) N.P.T. plugged tapping, accessible for test gauge connection, must be placed immediately upstream of the gas supply connection to the appliance.
2. The appliance and its individual shutoff valve must be disconnected from the gas supply piping system during any pressure testing of that system at test pressures in excess of 1/2 psig (3.5 kPa).
3. The appliance must be isolated from the gas supply piping system by closing its individual manual shutoff valve during any pressure testing of the gas supply piping system at test pressures equal to or less than 1/2 psig (3.5 kPa).

**Attention!** If one of the procedures results in pressures in excess of 1/2 psig (14" w.c.) (3.5 kPa) on the appliance gas valve, it will result in a hazardous condition.

#### Checking Manifold Pressure

Both Propane and Natural gas valves have a built-in pressure regulator in the gas valve. Natural gas models will have a manifold pressure of approximately 3.5" w.c. (.871kPa) at the valve outlet with the inlet pressure to the valve from a minimum of 4.5" w.c. (1.120kPa) for the purpose of input adjustment to a maximum of 10.5" w.c. (2.614kPa) Propane gas models will have a manifold pressure approximately 10.0" w.c. (2.49kPa) at the valve outlet with the inlet pressure to the valve from a minimum of 11.0" w.c. (2.739kPa) for the purpose of input adjustment to a maximum of 13.0" w.c. (3.237kPa).

A 1/8" (3.175mm) N.P.T. plugged tapping, accessible for test gauge connection, is located on the outlet side of the gas control.

#### High Altitudes

For altitudes/elevations above 2,000 feet (610m), input ratings should be reduced at the rate of 4 percent for each 1,000 (305m) feet above sea level. **Canadian High Altitudes** for locations having an elevation above mean sea level between 2,000 feet (610m) and 4,500 feet (1370m), the manifold pressure is to be decreased from 3.5" w.c. (.871kPa) to 3.0" w.c. (.747kPa) for Natural Gas and from 10.0" w.c. (2.49kPa) to 8.0" w.c. (1.992kPa) for Propane Gas.

#### Piezo Pilot Ignitor Instructions

Depressing the red button completely causes a spark to occur at the pilot. This is a substitute for a match which requires opening the pilot hole cover.

To light the pilot, it is important that the electrode be 1/8" (3mm) from the thermopile. The spark must occur at the point the burner flame hits the thermopile. The end of the electrode will be red hot with the pilot on.

On a new installation with air in the gas line, it is suggested that a match be used. The match will light the pilot faster than the piezo under this condition.

### FINISHING INSTRUCTIONS

#### Plastering (Figure 4)

In new construction use only plain (not perforated) gypsum lath around furnace and vent pipe so that plaster "Keys" will not project into wall space.

Use wood strips nailed to inside of studs and top of bottom plate. These must be removed before installation of furnace. Lath and plaster against top projection of Header Plate.

Do not allow wall finish materials to project into furnace recess.

#### Installing Furnace (Figure 5)

Clear the recess of all debris, and remove any wood plaster-grounds. Stand the furnace on floor in front of wall opening.

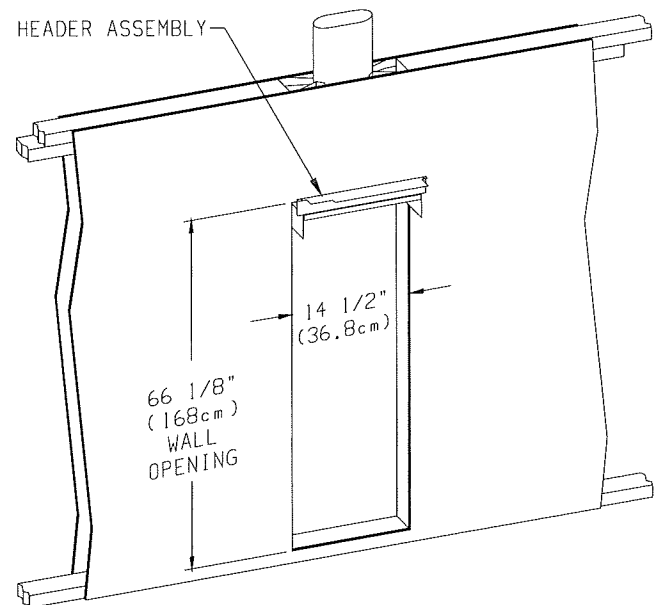
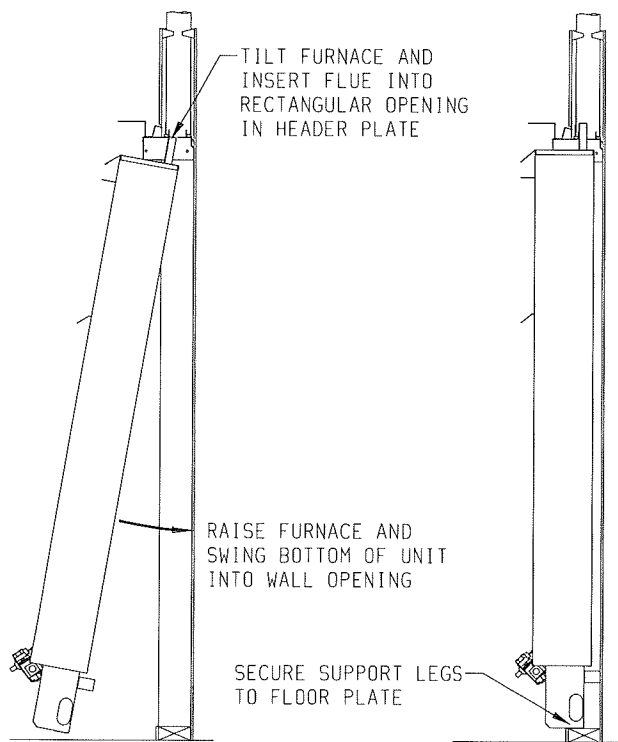

Figure 4

Insert furnace flue into rectangular opening in header plate and raise furnace carefully (see Figure 5). Swing bottom of furnace into wall opening with back of legs flush with rear of floor plate. Secure furnace support legs to the floor plate.



**Figure 5**

**IMPORTANT** — Avoid securing too tightly and disturbing the inner casing. Do not try to force furnace into a wall opening which is smaller than specified dimension.

**OUTER CASING (Figure 6)**

The shadow trim is factory installed onto the outer casing. For field installation, remove the two bottom #10 x 1/2" screws which attach the shadow trim to the outer casing. Now, align the screw holes on the casing brackets with the bottom screw holes on the shadow trim. Refer to Figure 6 for proper positioning of the 1 5/8" long slots on the casing brackets. Reattach the two #10 x 1/2" screws through the bottom holes on the outer casing, shadow trim and casing brackets.

Place outer casing with attached shadow trim in front of furnace. Align slots at the top of the shadow trim with the screw holes at the top of the header assembly. Position the entire length of the shadow trim flush with the wall surface. Attach the top of the shadow trim to the header assembly with (2) #8 x 3/8" pan-head Phillips screws supplied in hardware package.

Position the casing brackets at the bottom of the shadow trim between the bottom of the inner casing and the furnace legs. Align the slots on the casing brackets with the screw holes on the inner casing. Check again to insure the entire length of the shadow trim is flush with the wall surface. Attach the casing brackets to the inner casing with (2) #10 x 3/8" truss-head Phillips screws supplied in hardware package.

**Optional Step (Not Required)**

To square the bottom of the outer casing with the wall opening, align the edge of the 5/8" (16mm) flange on the shadow trim with the wall opening. Attach the shadow trim to the wall surface with (2) #10 x 1" screws supplied in hardware package.

**INSTALLING CONTROL DOOR**

Attach two washers supplied in hardware package to pivot pins located at bottom of control door. Install control door to outer casing assembly.

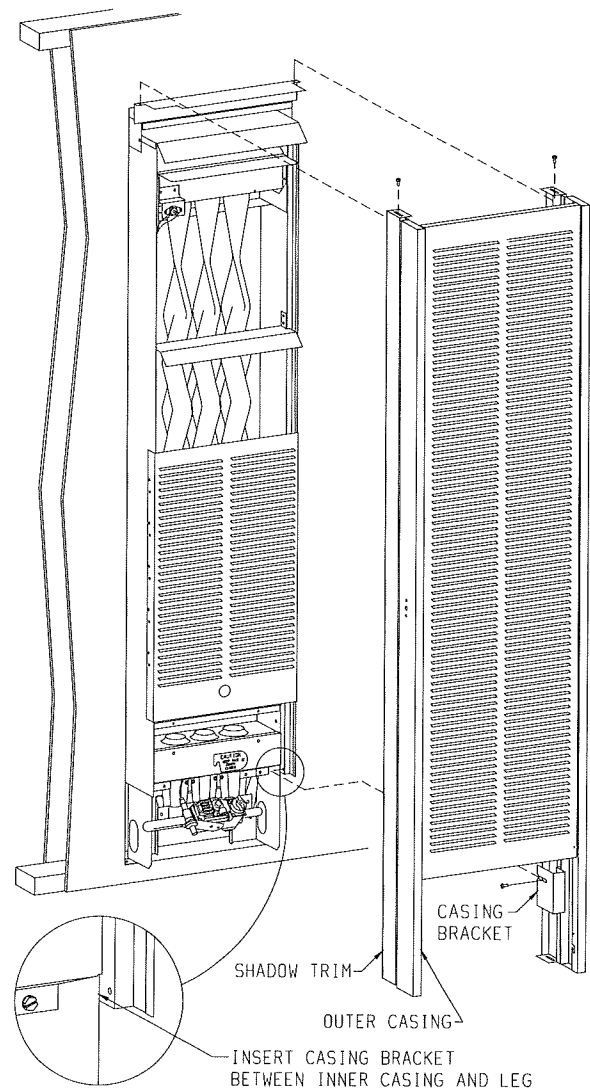

**Figure 6**

**THERMOSTAT LOCATION (SG MODELS)**

**CAUTION** — Do not run wire behind flanges of Header Plate or in any location where it might be damaged.

Millivolt wall thermostats are specially designed for use on self-generating systems. They should **never** be used on **line** or **low** voltage A.C. circuits.

**Interior Wall** — The thermostat should be installed on an inside wall away from the furnace but in the same room.

**Note:** Use 16 gauge wire to prevent excessive loss of millivolts.

Proper operation depends on a good pilot flame. The flame must cover the top of the thermopile. Cleaning of the pilot orifice and burner may be required due to spiders.

### System Check (Figure 7)

A millivolt meter is required to check the system. Millivolt readings should be:

- Across the thermopile terminals, 400-450 millivolts with thermostat OFF.
- Across the thermopile terminals, 150-250 millivolts with thermostat ON.
- Across the thermostat wires at the valve, less than 30 millivolts with thermostat ON.
- Across the thermostat wires at the thermostat, less than 5 millivolts with thermostat ON. (Dirty pilot or low pressure will reduce readings.)

Connect thermostat wires to gas valve as shown in Figure 7.

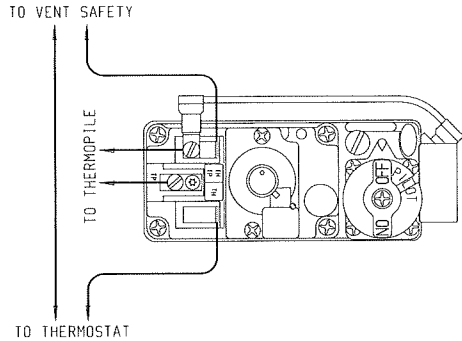

Figure 7

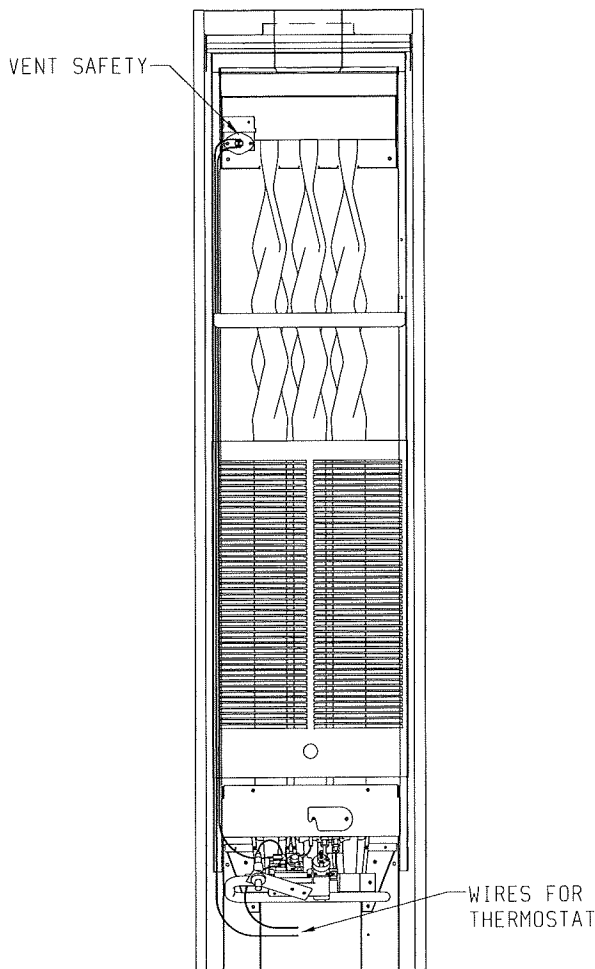

Figure 8

### Vent Safety Shutoff System (Figure 8)

This appliance must be properly connected to a venting system. This appliance is equipped with a vent safety shutoff system.

**Warning: Operation of this wall furnace when not connected to a properly installed and maintained venting system or tampering with the vent safety shutoff system can result in carbon monoxide (CO) poisoning and possible death.**

This furnace is equipped with a manual reset vent safety switch. The manual reset vent safety switch will cause gas flow to the main burner to "shut off" due to improper venting or a blocked flue.

To reset the manual reset vent safety switch:

1. Remove outer casing.
2. Depress manual reset button. The manual reset vent safety switch is located on the draft diverter.
3. Replace outer casing.

If the manual reset vent safety switch continues to "shut off" the gas flow to the main burner a qualified service person must be contacted to inspect for improper venting, blockage in the vent pipe or the manual reset vent safety switch for being defective.

### Proper Main Burner Flame (Figure 9)

The correct flame will be a short blue inner flame with a much larger light blue outer flame. The burner does not have a primary air adjustment. The flame will be proper if the factory-set pressure and orifice are used. After the furnace has begun operating, cleaning of the burner may be needed for proper flame, examine at least 2 times per season.

To clean burner ports, disconnect the gas supply to the valve. Remove the burner assembly from the combustion chamber. Remove pilot burner from main burner and then remove the main burner. Force water into the ports and blow dry with vacuum cleaner air, or low pressure compressed air.

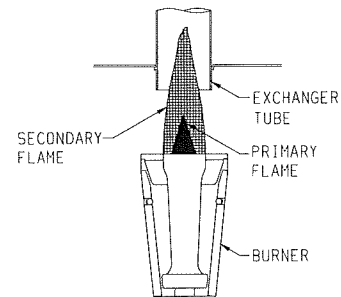

Figure 9

### Proper Pilot Flame (Figure 10)

The correct flame will be blue, extending past the thermopile. The flame will surround the thermopile just below its tip.

Natural gas pilots require adjusting when the inlet gas pressure is above 5" w.c. (1.245kPa). Remove the pilot cover screw on the control valve and turn the adjustment screw clockwise to reduce flame. Replace pilot cover screw to eliminate gas leaking at that control valve opening.

LP gas (propane) will not require adjustment.

After use, cleaning may be required for the proper flame.

Examine the pilot flame before and during each heating season.

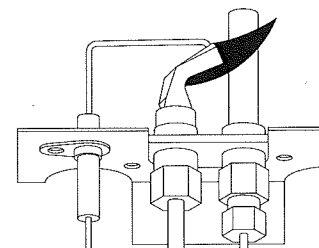

Figure 10



# FOR YOUR SAFETY READ BEFORE LIGHTING

**WARNING:** If you do not follow these instructions exactly, a fire or explosion may result causing property damage, personal injury or loss of life.

- A. This appliance has a pilot which must be lighted by hand. When lighting the pilot, follow these instructions exactly.
- B. **BEFORE LIGHTING** smell all around the appliance area for gas. Be sure to smell next to the floor because some gas is heavier than air and will settle on the floor.

## WHAT TO DO IF YOU SMELL GAS

- Do not try to light any appliance.
- Do not touch any electrical switch; do not use any phone in your building.
- Immediately call your gas supplier from a neighbor's phone. Follow the gas supplier's instructions.

- If you cannot reach your gas supplier, call the fire department.

- C. Use only your hand to push in or turn the gas control knob. Never use tools. If the knob will not push in or turn by hand, don't try to repair it; call a qualified service technician. Force or attempted repair may result in a fire or explosion.
- D. Do not use this appliance if any part has been under water. Immediately call a qualified service technician to inspect the appliance and to replace any part of the control system and any gas control which has been under water.

## LIGHTING INSTRUCTIONS

1. **STOP!** Read the safety information above.
2. Set the thermostat to lowest setting.
3. Turn off all electric power to the appliance (if applicable).
4. Remove control access panel (control door).
5. Push in gas control knob slightly and turn clockwise to "OFF."

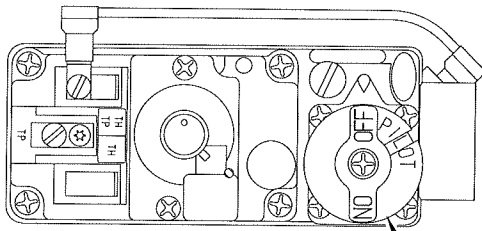

GAS CONTROL KNOB SHOWN IN "OFF" POSITION

**NOTE:** Knob cannot be turned from "PILOT" to "OFF" unless knob is pushed in slightly. Do not force.

6. Wait ten (10) minutes to clear out any gas. Then smell for gas, including near the floor. If you smell gas, **STOP!** Follow "B" in the safety information above. If you don't smell gas, go to the next step.

7. Find pilot - follow metal tube from gas control. The pilot is mounted on front of main burner.

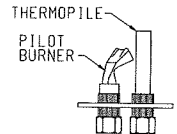

8. Turn gas control knob counterclockwise to "PILOT."
9. Push in control knob all the way and hold in. Immediately light the pilot with the Piezo Pilot Ignitor or a match. Continue to hold the control knob in for about one (1) minute after the pilot is lit. Release knob and it will pop back up. Pilot should remain lit. If it goes out, repeat steps 5 through 9.

- If knob does not pop up when released, stop and immediately call a qualified service technician or gas supplier.
- If the pilot will not stay lit after several tries, turn the gas control knob to "OFF" and call your service technician or gas supplier.

10. Turn gas control knob counterclockwise to "ON."
11. Replace control access panel (control door).
12. Turn on all electric power to the appliance (if applicable).
13. Set thermostat to desired setting.

## TO TURN OFF GAS TO APPLIANCE

1. Set the thermostat to lowest setting.
2. Turn off all electric power (if applicable) to appliance if service is to be performed.
3. Remove control access panel (control door).
4. Push in gas control knob slightly and turn clockwise to "OFF." Do not force.
5. Replace control access panel (control door).

# SERVICE AND MAINTENANCE SUGGESTIONS

## CALL SERVICEMAN

**GENERAL** All furnaces have been fire-tested to check for proper operation. This includes main burner flame, pilot flame, and gas control operation. If the furnace fails to function on initial installation, it is advisable to re-check the following:

1. Inlet gas pressure.
2. Type of gas being used and that shown on the rating plate.

The Service Department at Empire Comfort Systems, Inc. may be contacted to assist in servicing furnace.

### Servicing the Pilot and Main Burner, Pilot Orifice, Thermopile and Main Burner Orifice

Disconnect the gas supply at the inlet to the control valve. Remove the burner assembly to which the above components are attached.

### Spark Igniter Does Not Light Pilot

With air in the gas line, such as when the furnace is first installed or was "OFF" all summer, the pilot flame may be too lean to ignite on the first few trials. Turn the gas control knob to PILOT position and depress the gas control knob. Hold the gas control knob down to bleed the line;

1. Use lighter rod to light pilot with a match.
2. Use the spark generator at 30 second intervals until the pilot lights.

### If Electrode Does Not Produce Spark

1. Check wire connections.
2. Check gap for pilot burner to the electrode tip. The gap should be approximately 1/8" (3.2mm) to 3/16" (4.8mm). Electrode wire and tip must be more than 1/4" (6.4mm) away from all other metal components.

### If Pilot Does Not Light By Any Means

1. Check gas control knob for being in the "Pilot" position.
2. Check pilot adjustment for being full open (counterclockwise to open).
3. If gas is available in the supply tubing, the pilot orifice and/or pilot burner is probably restricted by a spider web. Clean pilot assembly and relight.

### If Pilot Does Not Remain "On" After Releasing Gas Control Knob

1. Follow instructions and hold gas control knob down longer and harder.
2. Determine if pilot flame extends past thermopile; if not, adjust pilot flame or clean pilot burner.
3. Replace thermopile if millivolt reading is less than 300 millivolts when wall thermostat or remote bulb is turned OFF. Replace gas control if magnet dropout millivolt reading is over 100 millivolts.

### Pilot Outage During Normal Operation

1. Check input by manifold pressure gauge or gas meter.
2. Check millivolt output when furnace is in operation. If millivolt output decreases during furnace operation gas control may be defective.

### Main Gas Valve Does Not Open When Thermostat Is Turned "On"

1. Check millivolt output of thermopile.
2. Thermostat wires may be broken.
3. Thermostat may be defective.

**PLEASE NOTE:** When ordering parts, it is very important that **part number** and **description** of part coincide.

INDEX NO.	PART NUMBER	DESCRIPTION	INDEX NO.	PART NUMBER	DESCRIPTION
1	GWT-045	SHADOW TRIM (2 REQUIRED)	18	7422105	BURNER ORIFICE - GWT-25-1 LPG (3 REQUIRED)
2	GWT-080	OUTER CASING ASSEMBLY	18	7421116	BURNER ORIFICE - GWT-35-1 NAT (4 REQUIRED)
3	GWT-164	CASING BRACKET	18	7422105	BURNER ORIFICE - GWT-35-1 LPG (4 REQUIRED)
4	GWT-164	CASING BRACKET	19	R-3031	BURNER (GWT-25-1 - 3 REQUIRED) (GWT-35-1 - 4 REQUIRED)
5	EL-158	MAGNET (2 REQUIRED)	20	R-2708	PIEZO IGNITOR
6	GWT-087	CASING DOOR ASSEMBLY	21	GWT-022	PIEZO BRACKET
7	8520103	NYLON WASHER (2 REQUIRED)	22	R-3032	GAS VALVE - NAT
8	R-3039	ELECTRODE AND WIRE ASSEMBLY	22	R-3033	GAS VALVE - LPG
9	GWT-021	PILOT BRACKET	23	GWT-070	BURNER BRACKET ASSEMBLY - GWT-25-1
10	672064	THERMOPILE	23	GWT-073	BURNER BRACKET ASSEMBLY - GWT-35-1
11	R-3035	PILOT - LPG	24	GWT-068	EXCHANGER ASSEMBLY - GWT-25-1
11	R-3034	PILOT - NAT	24	GWT-069	EXCHANGER ASSEMBLY - GWT-35-1
12	DV-064	COVER PLATE	25	GWT-077	HEAT SHIELD
13	GWT-009	BURNER COMPARTMENT FRONT - GWT-25-1 NAT	26	GWT-020	FRONT SHIELD
13	GWT-010	BURNER COMPARTMENT FRONT - GWT-25-1 LPG	27	R-3239	VENT SAFETY SWITCH - GWT-25-1
13	GWT-007	BURNER COMPARTMENT FRONT - GWT-35-1 NAT	27	R-3045	VENT SAFETY SWITCH - GWT-35-1
13	GWT-008	BURNER COMPARTMENT FRONT - GWT-35-1 LPG	28	R-3038-A	ECO LEAD ASSEMBLY
14	GWT-006	INLET PLATE - GWT-25-1 NAT	29	GWT-065	DIVERTER ASSEMBLY - GWT-25-1
14	GWT-005	INLET PLATE - GWT-35-1 NAT	29	GWT-066	DIVERTER ASSEMBLY - GWT-35-1
15	GWT-014	AIR SHUTTER FRONT - GWT-25-1	30	GWT-064	INNER CASING ASSEMBLY
15	GWT-011	AIR SHUTTER FRONT - GWT-35-1	31	GWT-083	HEADER ASSEMBLY (INCLUDES NO. 32, GASKET)
16	GWT-016	AIR SHUTTER BOTTOM - GWT-25-1 NAT	32	WFA-115	HEADER GASKET
16	GWT-054	AIR SHUTTER BOTTOM - GWT-25-1 LPG	NOT SHOWN	GWT-121	PILOT TUBING - GWT-25-1
16	GWT-013	AIR SHUTTER BOTTOM - GWT-35-1 NAT	NOT SHOWN	GWT-076	PILOT TUBING - GWT-35-1
16	GWT-049	AIR SHUTTER BOTTOM - GWT-35-1 LPG	NOT SHOWN	742266	PILOT ORIFICE (HONEYWELL .009 LPG ONLY)
17	GWT-015	AIR SHUTTER REAR - GWT-25-1	NOT SHOWN	742158	PILOT ORIFICE (HONEYWELL .014 NAT ONLY)
17	GWT-012	AIR SHUTTER REAR - GWT-35-1	NOT SHOWN	662021	MILLIVOLT WALL THERMOSTAT
18	7421117	BURNER ORIFICE - GWT-25-1 NAT (3 REQUIRED)	NOT SHOWN	6620100	RB THERMOSTAT

**USE ONLY MANUFACTURER'S REPLACEMENT PARTS. USE OF ANY OTHER PARTS COULD CAUSE INJURY OR DEATH.**

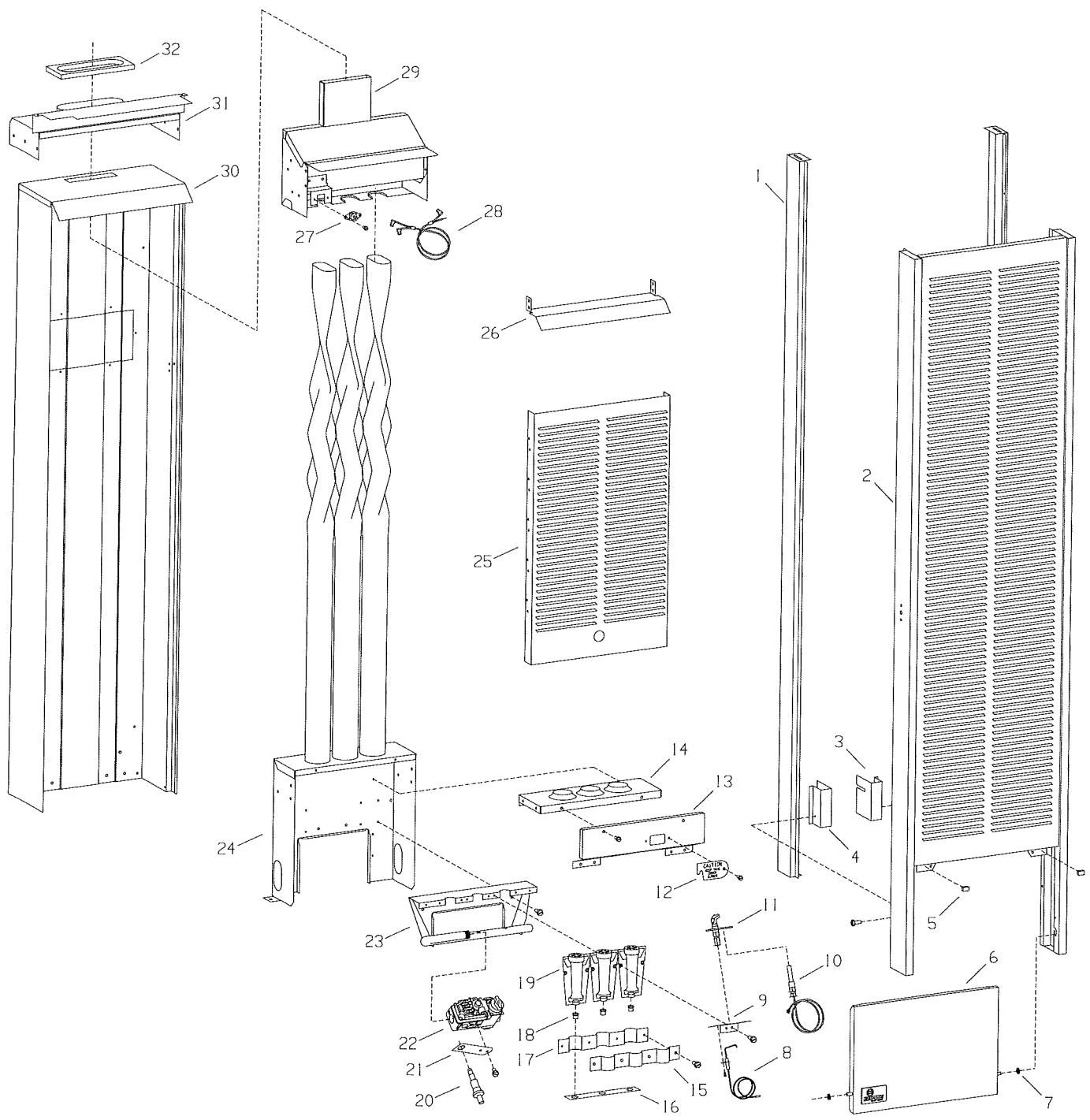

**How To Order Repair Parts . . .**

Parts can be ordered **only** through your **service person or dealer**. For best results, the **service person or dealer** should order parts through the distributor. Parts can be shipped directly to the **service person/dealer**.

All parts listed in the Parts List have a Part Number. When ordering parts, first obtain the Model Number from the name plate on your equipment. Then determine the Part Number (**not** the Index Number) and the Description of each part from the following appropriate illustration and list. Be sure to give all this information . . .

Furnace Model Number \_\_\_\_\_

Part Description \_\_\_\_\_

Furnace Serial Number \_\_\_\_\_

Kind of Gas (Propane or Natural) \_\_\_\_\_

Part Number \_\_\_\_\_

Do not order bolts, screws, washers or nuts. They are standard hardware items and can be purchased at any local hardware store.

Shipments contingent upon strikes, fires and all causes beyond our control.

# REMOTE BULB CONTROL INSTALLATION INSTRUCTIONS

GWT-25 RB  
GWT-35 RB  
GWT-50 RB

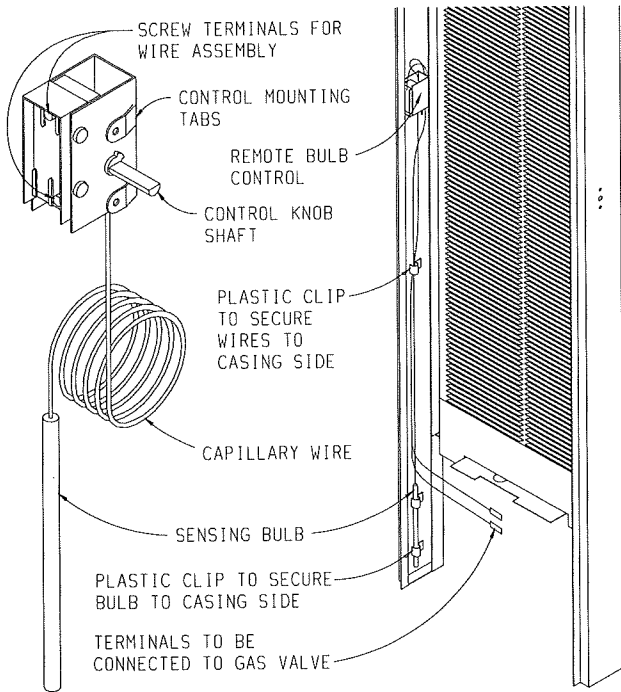

## INSTRUCTIONS

*Note: At the option of the owner, the remote bulb control may be located on the left or right side of the outer casing.*

1. Remove remote bulb control from the shipping carton.
2. Remove outer casing assembly from shipping carton.  
**Note:** If wall furnace is already installed, remove outer casing from unit and lay on floor with front side down.
3. Attach wire assembly to remote bulb control.
4. Carefully unwind capillary wire on remote bulb control.
5. Remove (3) hole plugs from left or right side of outer casing where remote bulb control is to be installed.
6. Mount remote bulb control to inside of outer casing with (2) No. 6-32 x 1/4" (6mm) screws.

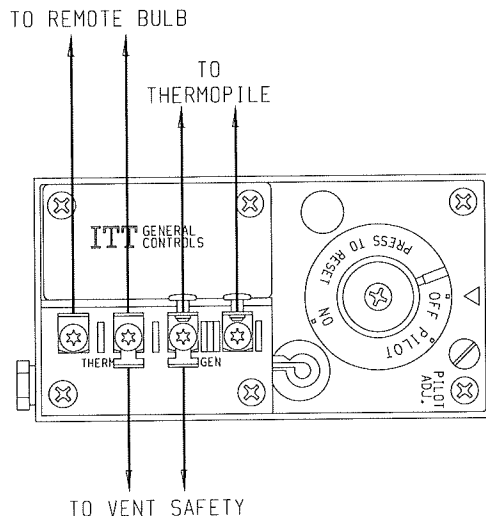

Index No.	Part Number	Description
1	GW-130	Remote Bulb Control Kit
2	R-1224	Remote Bulb Control
3	R-2499	Wire Assembly
4	R-1162	Control Knob
5	R-1720	Plastic Clip (3 Required)
6	R-1223	Instructions
7	R-1578	No. 6-32 x 1/4" (6mm) Screw (2 Required)

**Caution:** Remote bulb wire routing is important. Wires should be in proper location to avoid damage from being overheated. Incorrect routing of remote bulb control wires may result in damage to wires and incorrect operation of remote bulb control. Follow these instructions and refer to the drawing for proper wire routing.

7. If remote bulb control is located on the right side of the outer casing, carefully bend or loop capillary wire around control. This will enable the sensing bulb to be positioned at the bottom of the unit.
8. Secure sensing bulb on the inside, at the bottom, of the outer casing with (2) plastics clips.
9. Feed the wire assembly down along the inside of the outer casing.
10. Use third plastic clip to secure wire assembly and capillary wire to the casing. (Approximately 24" (610mm) from bottom of unit.)
11. Attach control knob to remote bulb control.
12. Install furnace according to instructions in the Installation Instructions and Owner's Manual.  
**Note:** If wall furnace is already installed, secure outer casing to unit.
13. Attach wire assembly to gas valve at the "TH" and "TH/TP" terminals on the Robertshaw valve.  
Attach wire assembly to gas valve at the "THERMO" terminals on the ITT valve. If the wire assembly has two 1/4" (6mm) female connectors, the connectors should be cut off the wire assembly. Strip and bare the wires and attach wires to the "THERMO" terminals.  
**Note:** This remote bulb control is connected to the gas valve the same way as a wall thermostat. Any references made to the thermostat in the lighting instructions would also apply to the remote bulb control.

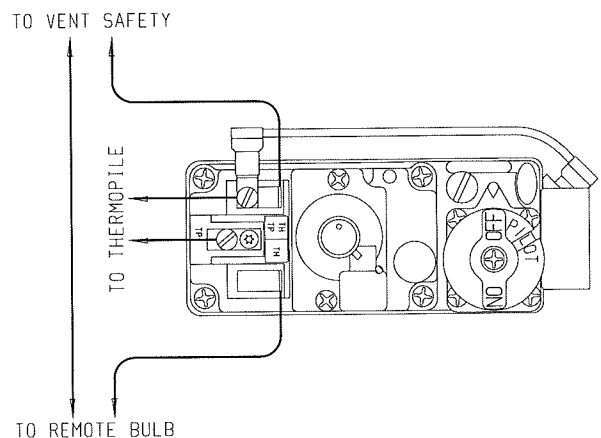



## OPTIONAL BLOWER INSTALLATION INSTRUCTIONS

**OPTIONAL BLOWER  
GWTB-1  
FOR MODELS  
GWT-25 (SG, RB)  
GWT-35 (SG, RB)  
GWT-50 (SG, RB)  
VENTED WALL FURNACES**

### Installing Blower Using Three-Prong Plug

1. Install furnace according to Installation Instructions and Owner's Manual.
2. Refer to Drawing for measurements to locate (2) mounting holes on wall surface above the furnace.

### On Solid Wall

3. After locating mounting holes, attach (2) #10 x 1 1/2" screws provided in blower kit into the wall. Do not completely tighten screwheads to the wall, leave a 7/16" gap between screwheads and wall.

### On Sheet Rock Wall

3. After locating mounting holes, drill (2) 5/16" diameter holes into the wall. Insert the (2) plastic expansion anchors into the holes. Insert the (2) #10 x 1 1/2" screws provided in blower kit into the (2) plastic expansion anchors. Do not completely tighten screwhead to the plastic expansion anchors, leave a 7/16" gap between screwheads and plastic expansion anchors.
4. At the top of the shadow trim loosen the (2) screws that attach the shadow trim to the header assembly. Also, loosen the (2) screws that attach the bottom of the outer casing to the inner casing. If applicable, remove the (2) screws that attach the bottom of the shadow trim to the wall.
5. Pull the outer casing with attached shadow trim forward approximately 1 inch away from the wall surface.
6. Position blower assembly on top of the header assembly and route three-prong cord set between the left, shadow trim and the inner casing.

**Caution:** Blower cord set routing is important. Cord set should be in proper location to avoid being overheated. Incorrect routing of cord set may result in damage to cord set.

7. Replace the outer casing with attached shadow trim to the wall surface.
8. Tighten (4) screws that attach shadow trim to header assembly and outer casing to inner casing. If applicable, replace (2) screws that attach shadow trim to wall.
9. Align key hole slots on back of blower housing with the (2) screws attached to wall. Position blower assembly flush with wall surface and on top of shadow trim and outer casing.
10. Installation of optional blower assembly is completed.

### Installing Blower With Hard Wiring

1. When facing the wall opening, install 120V electrical outlet junction box inside wall opening on left wall stud approximately 12 inches above header plate.
2. Refer to Drawing for measurements to locate access hole for electrical wiring on wall surface.
3. After locating access hole, drill a 1/2" hole into wall.
4. Route enough field wiring from 120V electrical outlet junction box through 1/2" access hole in wall for connection to blower housing.
5. Install furnace according to Installation Instructions and Owner's Manual.
6. Refer to Drawing for measurements to locate (2) mounting holes on wall surface above the furnace.

### On Solid Wall

7. After locating mounting holes, attach (2) #10 x 1 1/2" screws provided in blower kit into the wall. Do not completely tighten screwheads to the wall, leave a 7/16" gap between screwheads and wall.

### On Sheet Rock Wall

7. After locating mounting holes, drill (2) 5/16" diameter holes into the wall. Insert the (2) plastic expansion anchors into the holes. Insert the (2) #10 x 1 1/2" screws provided in blower kit into the (2) plastic expansion anchors. Do not completely tighten screwhead to the plastic expansion anchors, leave a 7/16" gap between screwheads and plastic expansion anchors.
8. Remove (4) screws that attach blower front to blower housing.
9. Remove three prong cord set from blower assembly.
10. Route 120V field wiring into blower housing through cord set hole on back of blower housing.
11. Refer to wiring diagram to make wiring connections inside blower housing. Be sure to follow all local and National electrical codes when making field wiring connections.
12. Attach blower front to blower housing with (4) screws removed in Step 8.
13. Align key hole slots on back of blower housing with the (2) screws attached to wall. Position blower assembly flush with wall surface and on top of shadow trim and outer casing.
14. Installation of optional blower assembly is completed.

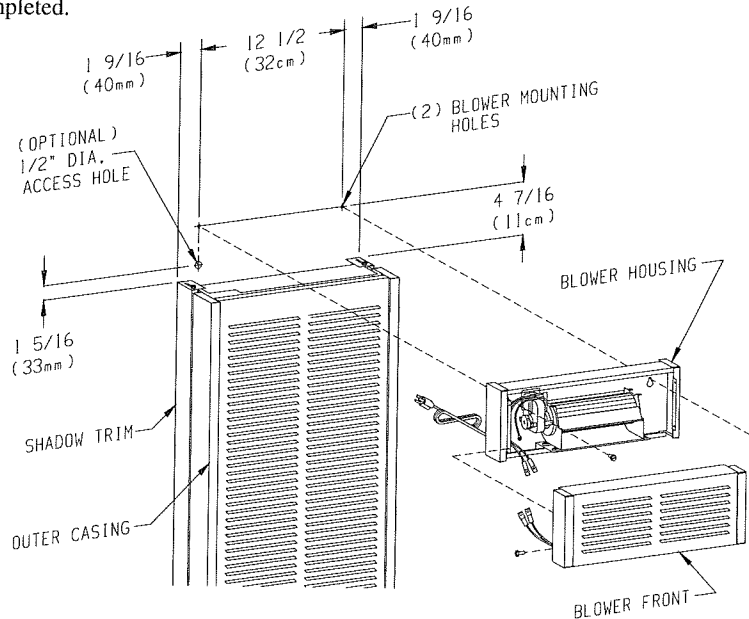

### Fan Control

The automatic fan control is located on the bottom of the blower assembly. The fan control is a nonadjustable, automatic type. The fan control will require between 3 and 7 minutes of main burner operation before the fan control "closes" and activates the blower. The blower will continue to run between 3 and 7 minutes after the main burner shuts off, before the fan control "opens" and deactivates the blower.

### Wiring

The appliance, when installed, must be electrically grounded in accordance with local codes or, in the absence of local codes, with the *National Electrical Code, ANSI/NFPA 70* or *Canadian Electrical Code, CSA C22.1*, if an external electrical source is utilized. **This appliance is equipped with a three-prong [grounding] plug for your protection against shock hazard and should be plugged directly into a properly grounded three-prong receptacle. Do not cut or remove the grounding prong from this plug.** For an ungrounded receptacle, an adapter, which has two prongs and a wire for grounding, can be purchased, plugged into the ungrounded receptacle and its wire connected to the receptacle mounting screws. With this wire completing the ground, the appliance cord plug can be plugged into the adapter and be electrically grounded.

#### WARNING:

**Unplugging of blower accessory will not stop the heater from cycling. To shut heater off: Turn temperature dial or thermostat to lowest setting. Turn knob on gas control to "OFF", depressing slightly. Do not force.**

**CAUTION:** Label all wires prior to disconnection when servicing controls. Wiring errors can cause improper and dangerous operation. Verify proper operation after servicing.

### Oiling

The blower motor does not have oiling holes. Do not attempt to oil the blower motor.

### PARTS LIST

INDEX NO.	PART NUMBER	DESCRIPTION
1	R-2204	CORD SET
2	R-1468	STRAIN RELIEF BUSHING
3	GWT-104	BLOWER HOUSING
4	R-1454	BRASS BUSHING (4 REQUIRED)
5	GWT-038	BLOWER HOUSING SIDE (2 REQUIRED)
6	R-3085	WIRE ASSEMBLY
7	R-2503	FAN SWITCH
8	GWT-036	BLOWER HOUSING FRONT
9	R-1499	RUBBER GROMMET (4 REQUIRED)
10	R-2804A	BLOWER MOTOR
NOT SHOWN	GWT-149	HARDWARE PACKAGE

### GWTB-1 WIRING DIAGRAM

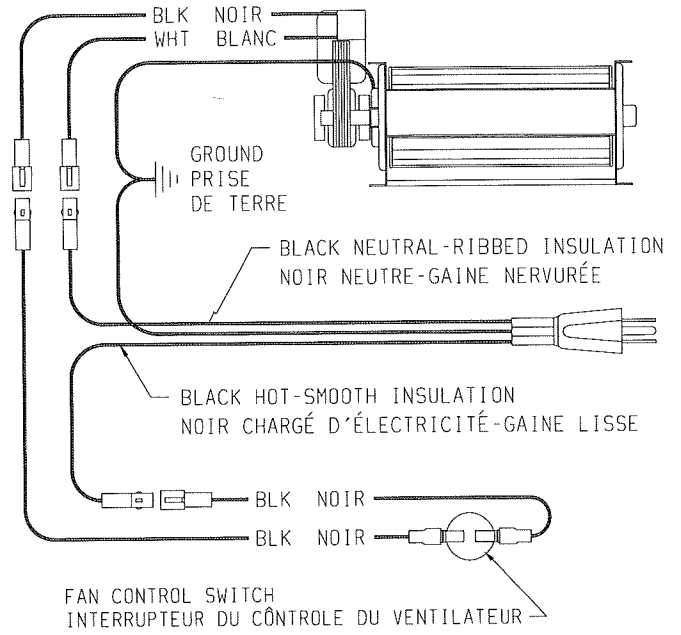

IF ANY OF THE ORIGINAL WIRE AS SUPPLIED WITH THIS UNIT MUST BE REPLACED, IT MUST BE REPLACED WITH 125°C WIRE OR ITS EQUIVALENT. S'IL Y A UN FIL ORIGINAL FOURNI AVEC L'APPAREIL QUI DOIT ÊTRE REMPLACÉ, IL DOIT ÊTRE REMPLACÉ AVEC UN FIL DU GENRE 125°C OU L'ÉQUIVALENT.

