



HEARTH PRODUCTS

This appliance may be installed in an aftermarket permanently located, manufactured home (USA only) or mobile home, where not prohibited by local codes. This appliance is only for use with the type of gas indicated on the rating plate. This appliance is not convertible for use with other gases, unless a certified kit is used.

In the Commonwealth of Massachusetts:

- Installation must be performed by a licensed plumber or gas fitter.

See Table of Contents for location of additional Commonwealth of Massachusetts requirements.

WARNING: IF THE INFORMATION IN THIS MANUAL IS NOT FOLLOWED EXACTLY, A FIRE OR EXPLOSION MAY RESULT CAUSING PROPERTY DAMAGE, PERSONAL INJURY OR LOSS OF LIFE.

FOR YOUR SAFETY: Do not store or use gasoline or other flammable vapors or liquids in the vicinity of this or any other appliance.

FOR YOUR SAFETY: What to do if you smell gas:

- DO NOT light any appliance.
- DO NOT touch any electrical switches.
- DO NOT use any phone in your building.
- Immediately call your gas supplier from a neighbor's phone. Follow your gas suppliers instructions.
- If your gas supplier cannot be reached, call the fire department.

Installation and service must be performed by a qualified installer, service agency or the gas supplier.

Tested &
Listed By



Portland
Oregon USA

OMNI-Test Laboratories, Inc.

OTL Report No. 116-F-47-5

A French manual is available upon request. Order Form Number 850,043CF.

Ce manuel d'installation est disponible en français, simplement en faire la demande. Numéro de la pièce 850,043CF.

INSTALLATION INSTRUCTIONS

DIRECT VENT MERIT™ PLUS SERIES

VENTED GAS FIREPLACE HEATERS - DIRECT VENT MODELS
P/N 850,043M REV. F 09/2008

MODELS

Millivolt Models

MPLDV-30NM
MPLDV-30PM
MPLDV-35NM-2
MPLDV-35PM-2
MPLDV-40NM
MPLDV-40PM
MPLDV-45NM
MPLDV-45PM

Electronic Models

MPLDV-30NE
MPLDV-35NE-2
MPLDV-40NE
MPLDV-45NE

INSTALLER: Leave this manual with the appliance.
CONSUMER: Retain this manual for future reference.

AVERTISSEMENT: ASSUREZ-VOUS DE BIEN SUIVRE LES INSTRUCTIONS DONNÉ DANS CETTE NOTICE POUR RÉDUIRE AU MINIMUM LE RISQUE D'INCENDIE OU POUR ÉVITER TOUT DOMMAGE MATÉRIEL, TOUTE BLESSURE OU LA MORT.

POUR VOTRE SÉCURITÉ: Ne pas entreposer ni utiliser d'essence ni d'autre vapeurs ou liquides inflammables dans le voisinage de cet appareil ou de tout autre appareil.

POUR VOTRE SÉCURITÉ: Que faire si vous sentez une odeur de gaz:

- Ne pas tenter d'allumer d'appareil.
- Ne touchez à aucun interrupteur. Ne pas vous servir des téléphones se trouvant dans le bâtiment où vous vous trouvez.
- Evacuez la pièce, le bâtiment ou la zone.
- Appelez immédiatement votre fournisseur de gaz depuis un voisin. Suivez les instructions du fournisseur.
- Si vous ne pouvez rejoindre le fournisseur de gaz, appelez le service des incendies.

L'installation et service doit être exécuté par un qualifié installateur, agence de service ou le fournisseur de gaz.

TABLE OF CONTENTS

Packaging	page 2
Introduction	page 2
General Information	page 2
Location	page 4
Appliance and Vent Clearances	page 5
Requirements for Commonwealth of Massachusetts	page 5
Vent Termination Clearances	page 5
Typical Installation Sequence	page 6
Detailed Installation Steps	page 6
Step 1. Framing	page 6
Step 2. Routing Gas Line	page 6
Fireplace Specifications	page 9
Step 3. Install the Vent System	page 10
Vertical Termination Systems	page 10
Vent Section Length Chart	page 11
Vertical Vent Tables and Figures	page 14
Horizontal Termination System	page 15
Horizontal Vent Tables and Figures .	page 18
Venting Using Flexible Vent Pipe	page 21
Step 4. Field Wiring	page 22
Step 5. Connecting Gas Line	page 23
Step 6. Installing Logs	page 24
Step 7. Checking Unit Operation	page 24
Step 8. Installing Glass Door	page 24
Step 9. Burner Adjustments	page 25
Finishing Requirements	page 25
Cold Climate Insulation	page 26
Installation Accessories	page 26
Gas Conversion Kits	page 28

This manual is part of a set of three supporting this product. Refer to manuals 875,036M for Care & Operations and 750,230M for Log Placement Guide.

Please read and understand these instructions before beginning your installation.



We suggest that our gas hearth products be installed and serviced by professionals who are certified in the U.S. by the National Fireplace Institute® (NFI) as NFI Gas Specialists.

PACKAGING

The assembled vented gas fireplace heater is packaged with the following:

- 1 - The logs are packaged in a carton located within the firebox.
- 2 - One bag of volcanic stones is located in the bottom compartment.
- 3 - One envelope containing the literature package, which consists of the homeowner's manual, installation instructions, log set supplement, warranty, gas access plate, screws (4) and gasket. The envelope is located in the bottom compartment.
- 4 - One vent restrictor, to be used as detailed on page 10.
- 5 - One hood and one control compartment cover and one 45 degree starter elbow are strapped to the top of the unit.

INTRODUCTION

These fireplaces are designed, tested and listed for operation and installation with, and only with, **Secure Vent™** Direct Vent System Components, **Secure Flex™** Flexible Vent Components manufactured by Security Chimneys International and **Z-Flex™** Model GA Venting Systems, listed to UL1777 and ULCS635 manufactured by Flexmaster Canada Limited. These approved vent system components are labeled for identification. **DO NOT** use any other manufacturer's vent components with these appliances.

Millivolt appliances are designed to operate on natural or propane gas. A millivolt gas control valve with piezo ignition system provides safe, efficient operation. There is no optional blower with these units.

Electronic appliances are designed to operate on natural or propane gas. An electronic intermittent pilot ignition system provides safe, efficient operation. External electrical power is recommended to operate these units. If the system operates on line voltage with 3V adapters, two (2) "D" batteries can be used as a backup in case of a power outage. The electronic appliance can be operated solely with two (2) "D" batteries.

These appliances comply with National Safety Standards and are tested and listed by Omni-Test Laboratories (Report No. 116-F-47-5) to ANSI Z21.88 (in Canada, CSA-2.33), and CAN/CGA-2.17-M91 in both USA and Canada, as vented gas fireplace heaters.

Both millivolt and electronic versions of these appliances are listed by Omni-Test Laboratories for installation in bedrooms and mobile homes.

The Installation must conform to local codes or, in the absence of local codes, with the *National Fuel Gas Code, ANSI Z223.1/NFPA 54*, or the *Natural Gas and Propane Installation Code, CSA B149.1*.

The appliance, when installed, must be electrically grounded in accordance with local codes or, in the absence of local codes, with the *National Electrical Code, ANSI/NFPA 70*, or the *Canadian Electrical Code, CSA C22.1*.

DO NOT ATTEMPT TO ALTER OR MODIFY THE CONSTRUCTION OF THE APPLIANCE OR ITS COMPONENTS. ANY MODIFICATION OR ALTERATION MAY VOID THE WARRANTY, CERTIFICATION AND LISTINGS OF THIS UNIT.

GENERAL INFORMATION

Note: Installation and repair should be performed by a qualified service person. The appliance should be inspected annually by a qualified professional service technician. More frequent inspections and cleanings may be required due to excessive lint from carpeting, bedding material, etc. It is imperative that the control compartment, burners and circulating air passage ways of the appliance be kept clean. S'assurer que le brûleur et le compartiment des commandes sont propres. Voir les instructions d'installation et d'utilisation qui accompagnent l'appareil.

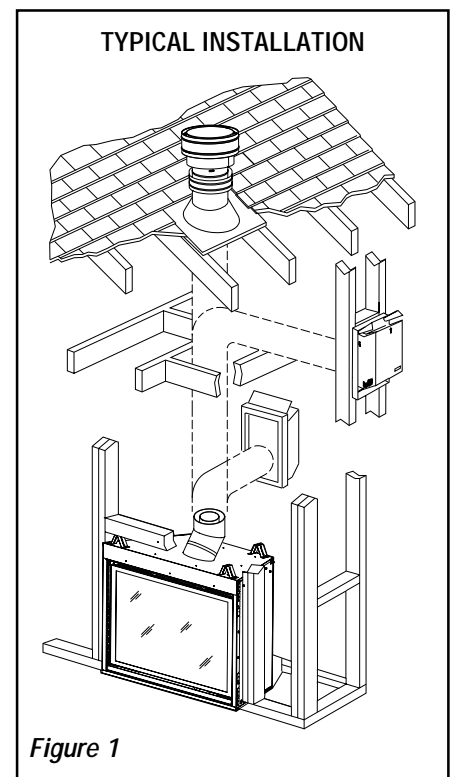

Figure 1

Provide adequate clearances around air openings and adequate accessibility clearance for service and proper operation. Never obstruct the front openings of the appliance.

These appliances are designed to operate on natural or propane gas only.

Millivolt And Electronic Models -

Millivolt and Electronic models come standard with the manually-modulated gas valve; flame appearance and heat output can be controlled at the gas valve.

Input of millivolt and electronic models is shown in the following table:

Millivolt And Electronic Models with Manually-Modulated Gas Valve			
Natural Gas		Propane Gas	
Model No.	Input rate (BTU/H)	Model No.	Input rate (BTU/H)
MPLDV30	13,000 to 10,000	MPLDV30	11,500 to 9,000
MPLDV35	19,000 to 15,000	MPLDV35	18,000 to 14,000
MPLDV40	25,000 to 18,500	MPLDV40	21,500 to 16,500
MPLDV45	26,000 to 20,000	MPLDV45	25,000 to 19,000

All Models -

Maximum manifold pressure is 3.5 in. w.c. (0.87 kPa) for natural gas and 10 in. w.c. (2.49 kPa) for LP/Propane gas.

Efficiencies%						
Models	Natural Gas			Propane		
	P4	Steady State	AFUE	P4	Steady State	AFUE
MPLDV30	58	65	63	58	66	64
MPLDV35	60	65	63	62	65	63
MPLDV40	58	67	64	57	67	65
MPLDV45	58	67	65	60	66	64

Note: Power venting of direct vent fireplaces may result in the reduction of efficiencies by as much as ten percent. Consider this in making any venting and heating decisions in any installation application.

Installations at Altitudes of 0 to 4500 ft.-
Units are tested and approved for elevations of 0 to 4500 feet (0 to 1372 meters).

Installations at Altitudes above 4500 ft.-
For elevations above 4500 feet (1372 meters), install the unit according to the regulations of the local authorities having jurisdiction and, in the USA, the latest edition of the National Fuel Gas Code (ANSI Z223.1) or, in Canada, the latest edition of the CAN1-B149.1 and .2 codes.

Table 1 shows the units' gas orifice size for the elevations indicated.

The millivolt appliances are manually controlled and feature a spark ignitor (piezo) that allows the appliance's pilot gas to be lit without the use of matches or batteries. This system provides continued service in the event of a power outage.

Model No.	Orifice size		Elevation Feet (meters)
	Nat.	Prop.	
MPLDV30	0.070"	#61 (0.039")	0-4500 (0-1372)
MPLDV35	#45 (0.082")	0.048"	
MPLDV40	#41 (0.096")	#54 (0.055")	
MPLDV45	#40 (0.098")	#53 (0.0595")	

Table 1

Do not use these appliances if any part has been under water. Immediately call a qualified, professional service technician to inspect the appliance and to replace any parts of the control system and any gas control which have been under water.

Ne pas se servir de cet appareil s'il a été plongé dans l'eau, complètement ou en partie. Appeler un technicien qualifié pour inspecter l'appareil et remplacer toute partie du système de contrôle et toute commande qui ont été plongés dans l'eau.

This appliance may be installed in an aftermarket permanently located, manufactured home (USA only) or mobile home, where not prohibited by local codes. This appliance is only for use with the type of gas indicated on the rating plate. This appliance is not convertible for use with other gases, unless a certified kit is used.

Cet appareil peut être installé dans un maison préfabriquée (É.-U. seulement) ou mobile déjà installée à demeure si les règlements locaux le permettent.
Cet appareil doit être utilisé uniquement avec les types de gaz indiqués sur la plaque signalétique. Ne pas l'utiliser avec d'autres gaz sauf si un kit de conversion certifié est installé.

Test gage connections are provided on the front of the millivolt and electronic gas control valve (identified IN for the inlet and OUT for the manifold side). A 1/8" NPT test gage connection is provided at the inlet and outlet side of the electronic gas control valve.

Minimum inlet gas pressure to these appliances is 5.0 inches water column (1.24 kPa) for natural gas and 11 inches water column (2.74 kPa) for propane for the purpose of input adjustment.

Maximum inlet gas supply pressure to these appliances is 10.5 inches water column (2.61 kPa) for natural gas and 13.0 inches water column (3.23 kPa) for propane.

These appliances must be isolated from the gas supply piping system (by closing their individual manual shut-off valve) during any pressure testing of the gas supply piping system at test pressures equal to or less than 1/2 psig (3.5 kPa).

These appliances and their individual shut-off valves must be disconnected from the gas supply piping system during any pressure testing of that system at pressures in excess of 1/2 psig (3.5 kPa).

These appliances must not be connected to a chimney or flue serving a separate solid fuel burning appliance.

These heater rated appliances are intended for use as supplemental heaters only. Using these appliances as a primary heat source may void the manufacturers warranty.

Carbon Monoxide Poisoning: Early signs of carbon monoxide poisoning are similar to the flu with headaches, dizziness and/or nausea. If you have these signs, obtain fresh air immediately. Turn off the gas supply to the appliance and have it serviced by a qualified professional, as it may not be operating correctly.

WARNING: FAILURE TO COMPLY WITH THE INSTALLATION AND OPERATING INSTRUCTIONS PROVIDED IN THIS DOCUMENT WILL RESULT IN AN IMPROPERLY INSTALLED AND OPERATING APPLIANCE, VOIDING ITS WARRANTY. ANY CHANGE TO THIS APPLIANCE AND/OR ITS OPERATING CONTROLS IS DANGEROUS. IMPROPER INSTALLATION OR USE OF THIS APPLIANCE CAN CAUSE SERIOUS INJURY OR DEATH FROM FIRE, BURNS, EXPLOSION OR CARBON MON-OXIDE POISONING.

WARNING: CHILDREN AND ADULTS SHOULD BE ALERTED TO THE HAZARDS OF HIGH SURFACE TEMPERATURES. USE CAUTION AROUND THE APPLIANCE TO AVOID BURNS OR CLOTHING IGNITION. YOUNG CHILDREN SHOULD BE CAREFULLY SUPERVISED WHEN THEY ARE IN THE SAME ROOM AS THE APPLIANCE.

WARNING: DO NOT PLACE CLOTHING OR OTHER FLAMMABLE MATERIALS ON OR NEAR THIS APPLIANCE.

AVERTISSEMENT: SURVEILLER LES ENFANTS. GARDER LES VÊTEMENTS, LES MEUBLES, L'ESSENCE OU AUTRES LIQUIDES À VAPEUR INFLAMMABLES À CÔTÉ DE L'APPAREIL.

LOCATION

In selecting the location, the aesthetic and functional use of the appliance are primary concerns. However, vent system routing to the exterior and access to the fuel supply are also important. Consideration should be given to traffic ways, furniture, draperies, etc., due to elevated surface temperatures (*Figure 2*).

The location should also be free of electrical, plumbing or other heating/air conditioning ducting. These direct vent appliances are uniquely suited for installations requiring a utility shelf positioned directly above the fireplace. Utility shelves like these are commonly used for locating television sets and decorative plants.

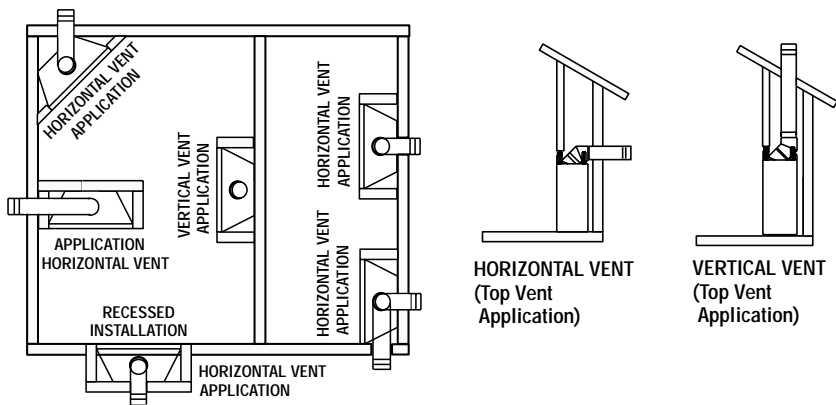

Figure 2

Typical Locations

Model No.	Shelf Height inches (mm)	
	Secure Vent	Secure Flex
MPLDV30	44 3/4 (1132)	44 3/4 (1132)
MPLDV35	46 3/4 (1188)	46 3/4 (1188)
MPLDV40/MPLDV45	51 3/4 (1314)	51 3/4 (1314)

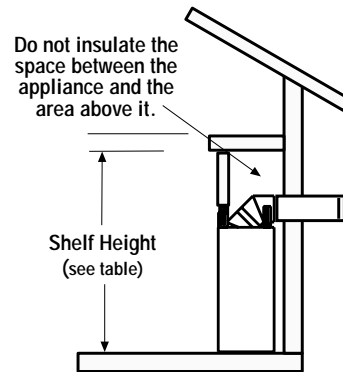

Figure 3

Shelf Above Fireplace With Top Venting

BACK	1 in. (25.4 mm) 0 in. (0 mm) spacers
SIDES	1 in. (25.4 mm)** 0 in. (0 mm) spacers
TOP SPACERS	0 in. (0 mm)
FLOOR	0 in. (0 mm)
From Bottom of Unit to Ceiling	64 in. (1626 mm)
VENT	1 in. (25.4 mm)*
SERVICE CLEARANCES	
FRONT	3 Feet. (0.9 meters)

***Note:** 3 in. (76mm) above any horizontal/ inclined vent component for the MPLDV30 in all cases, and for the MPLDV35, MPLDV40 & MPLDV45, when the vent center line is **greater than 48" (1219 mm)** above the fireplace top wrapper surface. Increase this clearance to 5" (127 mm) for the MPLDV35, MPLDV40 & MPLDV45, when the vent center line is **less than 48" (1219 mm)** above the fireplace top wrapper surface.

****Note:** See **page 6, step 1** for clearance requirements to the nailing flange located at each side of the unit and any screw heads adjacent to it.

Table 2

To provide for the lowest possible shelf surface the venting attached to the top vent should be routed in a way to minimize obstructions to the use of the space above the appliance. **Do not insulate the space between the appliance and the area above it.** Refer to **Figure 3**. The minimum height from the base of the appliance to the underside of combustible materials used to construct a utility shelf in this fashion is shown in the table in **Figure 3**.

The appliance should be mounted on a fully supported base extending the full width and depth of the unit. The appliance may be located on or near conventional construction materials. However, if installed on combustible materials, such as carpeting, vinyl tile, etc., a metal or wood barrier covering the entire bottom surface must be used.

APPLIANCE AND VENT CLEARANCES

Refer To **Table 2** for approved clearances to combustibles for the models covered in this manual, with the following exception: When the unit is installed with one side flush with a wall, the wall on the other side of the unit must not extend beyond the front edge of the unit. In addition, when the unit is recessed, the side walls surrounding the unit must not extend beyond the front edge of the unit. See **Figure 2**.

Maintain a minimum 1" (25 mm) clearance to combustible materials for all vertical vent elements.

Clearances for horizontal vent elements are 1" (25 mm) at the sides and 1" (25 mm) on the bottom. Clearances above horizontal vent elements are 3" (76 mm) for all models and all applications. *Exception: Clearance is 5" (127 mm) for MPLDV35, MPLDV40 & MPLDV45, when the center line of the horizontal run is less than 48" (1219 mm) above the fireplace top wrapper surface.*

Massachusetts And New York City, NY Requirements

These appliances are approved for installation in the following USA locations listed in the following:

Massachusetts:

These fireplaces are approved for installation in the US state of Massachusetts if the following additional requirements are met-

- Installation and repair must be done by a plumber or gas fitter licensed in the Commonwealth of Massachusetts.
- The flexible gas line connector used shall not exceed 36 inches (92 centimeters) in length.
- The individual manual shut-off must be a T-handle type valve.

Massachusetts Horizontal Vent Requirements

In the Commonwealth of Massachusetts, horizontal terminations installed less than seven (7) feet above the finished grade must comply with the following additional requirements:

- A hard wired carbon monoxide detector with an alarm and battery back-up must be installed on the floor level where the gas fireplace is installed. The carbon monoxide detector must comply with NFPA 720, be ANSI/UL 2034 listed and be ISA certified.

- A metal or plastic identification plate must be permanently mounted to the exterior of the building at a minimum height of eight (8) feet above grade and be directly in line with the horizontal termination. The sign must read, in print size no less than one-half (1/2) inch in size, GAS VENT DIRECTLY BELOW. KEEP CLEAR OF ALL OBSTRUCTIONS.

New York City, NY:

These fireplaces are approved for installation in New York City in the US state of New York.

VENT TERMINATION CLEARANCES

These instructions should be used as a guideline and do not supersede local codes in any way. Install vent according to local codes, these instructions, the current National Fuel Gas Code (ANSI-Z223.1) in the USA or the current standards of CAN/CGA-B149.1 and -B149.2 in Canada.

Vertical Vent Termination Clearances

Terminate single vent caps relative to building components according to **Figure 4**.

Terminate multiple vent terminations according to the installation codes listed at the top of this page.

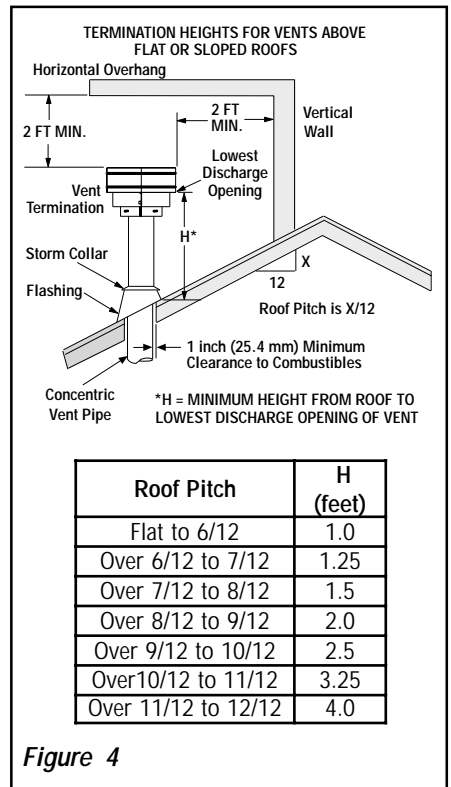

Figure 4

Horizontal Vent Termination Clearances

The horizontal vent termination must have a minimum of 3" (76 mm) clearance to any overhead combustible projection of 2-1/2" (64 mm) or less. See **Figure 5**. For projections exceeding 2-1/2" (64 mm), see **Figure 5**. All horizontal terminations may be located as close as 6" (152mm) to any (non-combustible and combustible) exterior sidewall. This distance may be decreased to 2" (51mm) for non-combustible exterior sidewalls only, if the SV4.5HT-2 termination is used. For additional vent location restrictions, refer to **Figure 8 on page 7**.

TYPICAL INSTALLATION SEQUENCE

The typical sequence of installation follows, however, each installation is unique resulting in variations to those described.

See the page numbers references in the following steps for detailed procedures.

Step 1. (page 6) Construct the appliance framing. Position the appliance within the framing and secure with nailing brackets.

Step 2. (page 6) Route gas supply line to appliance location.

Step 3. (page 10) Install the vent system and exterior termination. Install additional restrictor, if needed.

Step 4. (page 21) Field Wiring

a. Millivolt Appliances – The operating control switch is factory installed.

b. Electronic Appliances – Connect 120 Vac electrical power to the appliance receptacle.

Step 5. (page 22) Make connection to gas supply.

Step 6. (page 23) Install the logs and glowing embers.

Step 7. (page 23) Checkout appliance operation.

Step 8. (page 23) Install glass door frame assembly.

Step 9. (page 24) Adjust burner to ensure proper flame appearance.

DETAILED INSTALLATION STEPS

The appliance is shipped with all gas controls and components installed and pre-wired. Remove the shipping carton, exposing the front glass door. Remove the bottom panel by lifting and pulling it towards the front.

Open the two latches (located under the firebox floor) securing the glass door. Remove the door by tilting it outward at the bottom and lifting it up. Set the door aside protecting it from inadvertent damage. See **Figure 39 on page 23**.

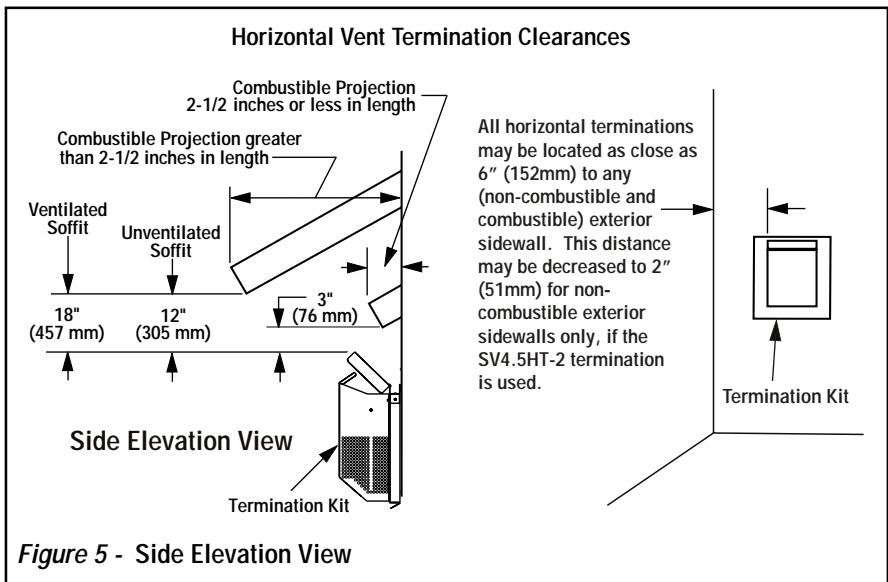

Step 1. FRAMING

Frame these appliances as illustrated in **Figure 9 on page 8**, unless the appliance is to be installed in a corner.

See **Figure 10 on page 8** for corner framing installations. All framing details must allow for a minimum clearance to combustible framing members as shown in **Table 2 on page 4**.

If the appliance is to be elevated above floor level, a solid continuous platform must be constructed. Headers may be in direct contact with the appliance top spacers but must not be supported by them or notched to fit around them. All construction above the appliance must be self supporting, **DO NOT** use the appliance for structural support.

The fireplace should be secured to the side framing members using the unit's nailing flanges - one top and bottom on each side of the fireplace front. See **Figure 6**. Use 8d nails or their equivalent.

Step 2. ROUTING GAS LINE

Route a 1/2" (13 mm) gas line along the inside of the left side framing as shown in **Figure 7**. Gas lines must be routed, constructed and made of materials that are in strict accordance with local codes and regulations.

All appliances are factory-equipped with a flexible gas line connector and 1/2 inch shutoff valve. (See **step 6 on page 22**).

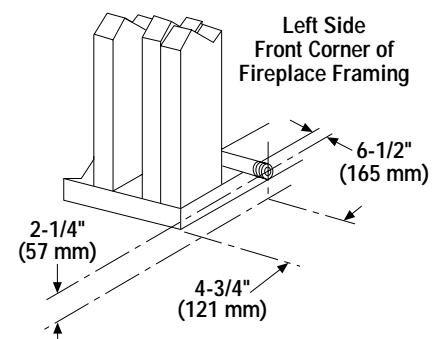

EXTERIOR HORIZONTAL VENT TERMINATION CLEARANCE REQUIREMENTS

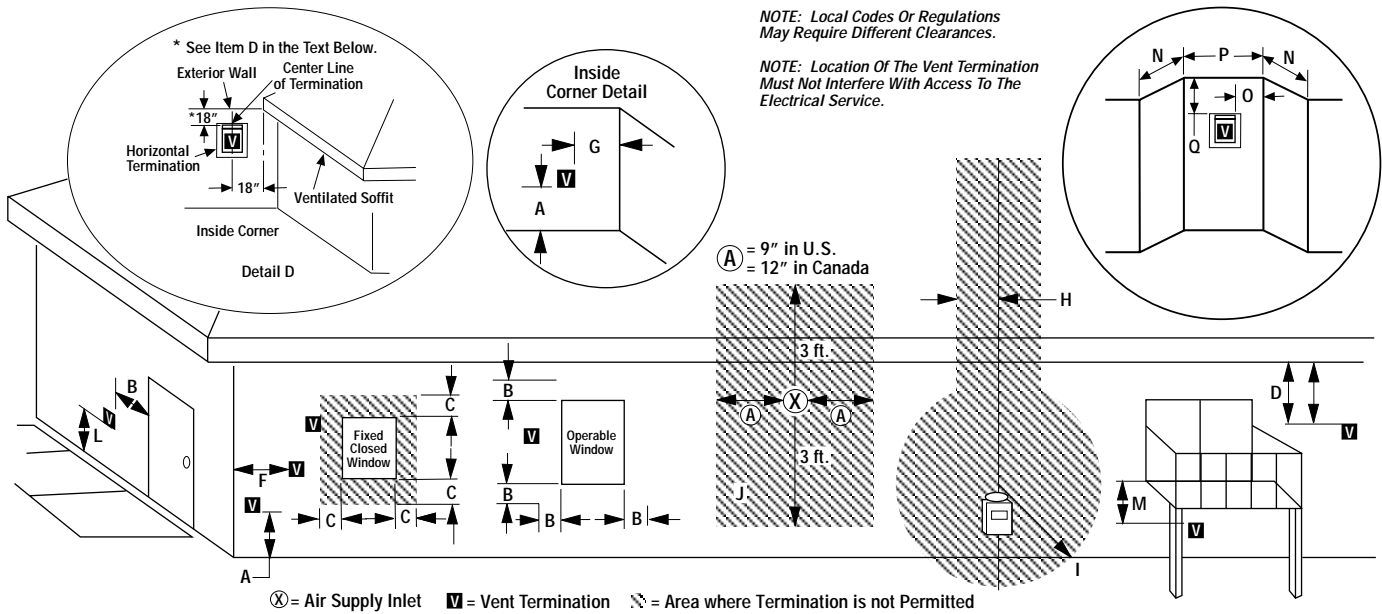

NOTE: Local Codes Or Regulations May Require Different Clearances.

NOTE: Location Of The Vent Termination Must Not Interfere With Access To The Electrical Service.

	Canadian Installation*	US Installation**
A = Clearance above grade, veranda, porch, deck, or balcony.	12 inches (30cm)*	12 inches (30cm)**
B = Clearance to window or door that may be opened.	6 inches (15cm) for appliances < 10,000 Btuh (3kW), 12 inches (30cm) for appliances > 10,000 Btuh (3kW)	6 inches (15cm) for appliances < 10,000 Btuh (3kW), 9 inches (23cm) for appliances > 10,000 Btuh (3kW) and < 50,000 Btuh (15kW), 12 inches (30cm) for appliances > 50,000 Btuh (15kW)**
C = Clearance to permanently closed window	12 inches (305mm) recommended to prevent window condensation	9 inches (229mm) recommended to prevent window condensation
D = Vertical clearance to ventilated soffit located above the termination within a horizontal distance of 18 inches (458mm) from the center line of the termination	18 inches (458mm)	18 inches (458mm)
E = Clearance to unventilated soffit***	12 inches (305mm)	12 inches (305mm)
F = Clearance to outside corner	5 inches (12.7cm) minimum	5 inches (12.7cm) minimum
G = Clearance to inside corner	6 inches (15.2cm) minimum	6 inches (15.2cm) minimum
H = Clearance to each inside of center line extended above meter/regulator assembly	3 feet (91cm) within a height of 15 feet above the meter/regulator assembly*	3 feet (91cm) within a height of 15 feet above the meter/regulator assembly**
I = Clearance to service regulator vent outlet	3 feet (91cm)*	3 feet (91cm)**
J = Clearance to nonmechanical air supply inlet to building or the combustion air inlet to any other appliance	6 inches (15cm) for appliances < 10,000 Btuh (3kW), 12 inches (30cm) for appliances > 10,000 Btuh (3kW)	6 inches (15cm) for appliances < 10,000 Btuh (3kW), 9 inches (23cm) for appliances > 10,000 Btuh (3kW) and < 50,000 Btuh (15kW), 12 inches (30cm) for appliances > 50,000 Btuh (15kW)**
K = Clearance to a mechanical air supply inlet	6 feet (1.83m)*	3 feet (91cm) above if within 10 feet (3m) horizontally**
L = Clearance above paved sidewalk or paved driveway located on public property	7 feet (2.13m)‡	7 feet (2.13m)‡
M = Clearance under veranda, porch, deck or balcony	12 inches (30cm)*‡	12 inches (30cm)‡
N = Depth of Alcove (Maximum)	6 feet (1.83m)*	6 feet (1.83m)**
O = Clearance to Termination (Alcove)	6 inches (15.2mm)*	6 inches (15.2mm)**
P = Width of Alcove (Minimum)	3 feet (91cm)*	3 feet (91cm)*
Q = Clearance to Combustible Above (Alcove)	18 inches (457mm)*	18 inches (457mm)**

* In accordance with the current CSA-B149.1 National Gas And Propane Installation Code.

** In accordance with the current ANSI S222.1/NFPA 54 National Fuel Gas Codes.

*** Clearance required to vinyl soffit material - 30 inches (76cm) minimum.

‡ A vent shall not terminate directly above a sidewalk or paved driveway which is located between two single family dwellings and serves both dwellings.

*‡ Only permitted if veranda, porch, deck or balcony is fully open on a minimum 2 sides beneath the floor:

Figure 8

NOTE: DIAGRAMS & ILLUSTRATIONS NOT TO SCALE.

FIREPLACE FRAMING SPECIFICATIONS

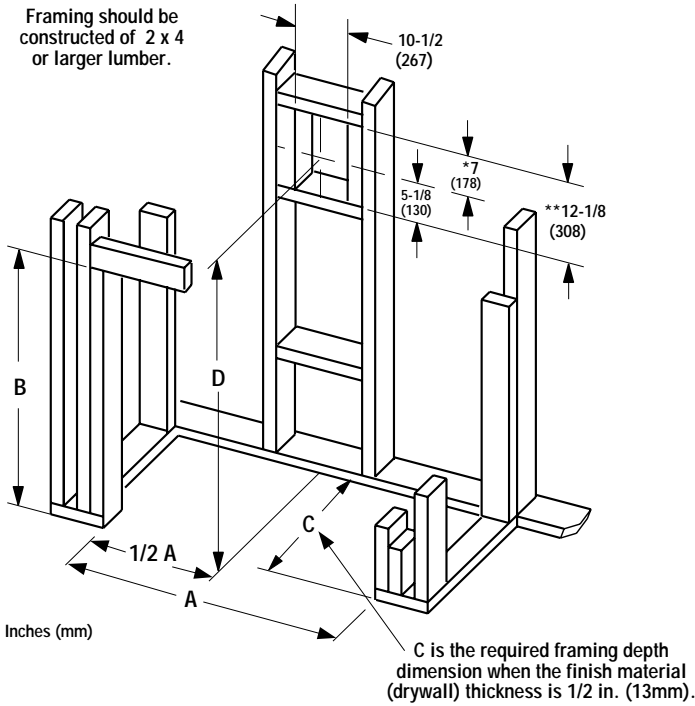

Model No.		A	B	C	D
MPLDV30	in.	30 9/16	40 3/4	16 1/2	38
	mm	786	1035	419	965
MPLDV35	in.	35 9/16	40 3/4	16 1/2	38
	mm	903	1035	419	965
MPLDV40	in.	40 9/16	45 3/4	16 1/2	43
	mm	1030	1162	419	1092
MPLDV45	in.	45 9/16	45 3/4	16 1/2	43
	mm	1157	1162	419	1092

*9" (229 mm) For MPLDV-35, 40 & 45

**14-1/8" (359 mm) For MPLDV-35, 40 & 45

Figure 9 Framing

Model No.		A	B	C	D	E
MPLDV30	in.	30 1/4	52 1/4	37	14 7/64	26 1/8
	mm	768	1327	940	358	664
MPLDV35	in.					
	mm					
MPLDV40	in.	40 1/4	62 1/4	44	17 5/8	31 1/8
	mm	1022	1581	1118	448	791
MPLDV45	in.					
	mm					

Note: The appliance 45° collar can be rotated about its axis to align for corner installation. Remove interfering corner spacer. This spacer is used for shipping only.

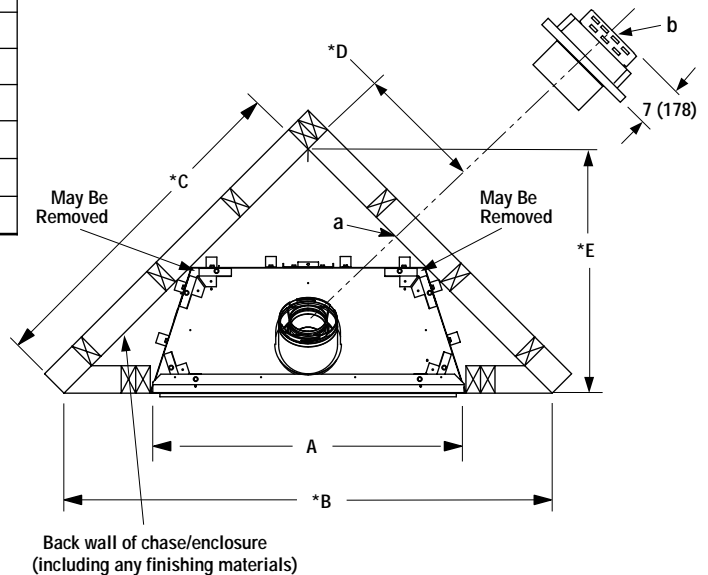

Note- Venting requirements for corner installations - the horizontal vent length "a" to "b," must not exceed 28 inches (711 mm)

*These dimensions occur when one 45 degree elbow is connected directly to the appliance collar.

Inches (millimeters)

Figure 10 Corner Framing with Square Termination (SV4.5HT-2)

FIREPLACE SPECIFICATIONS

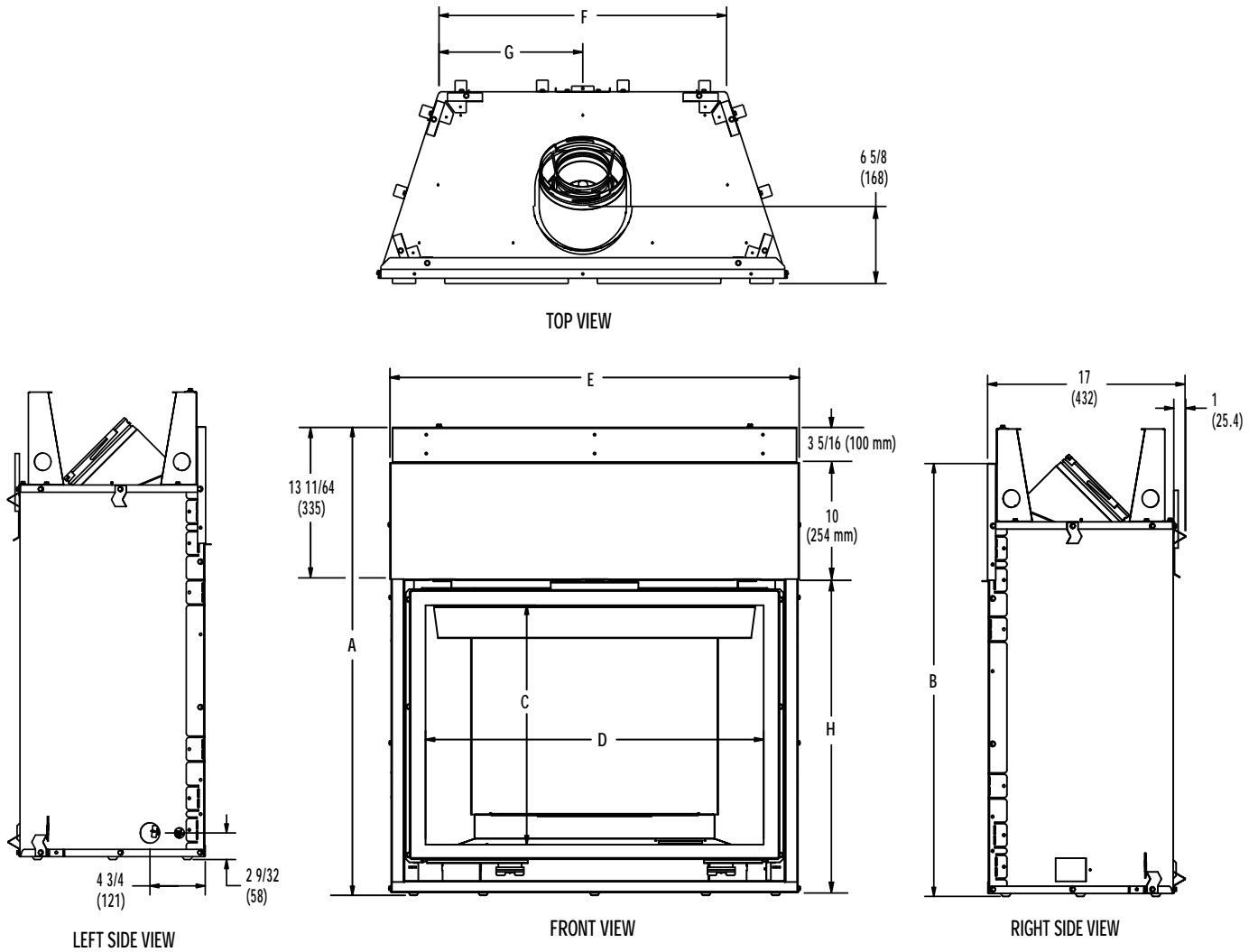

Unit Dimensions

Model No.		A	B	C	D	E	F	G	H
MPLDV30	in.	40 1/2	37 1/2	20 5/8	24 1/8	30 1/4	19 3/4	9 7/8	27 1/4
	mm	1029	953	534	613	768	502	251	692
MPLDV35	in.	40 1/2	37 1/2	20 5/8	29 1/8	35 1/4	24 3/4	12 3/8	27 1/4
	mm	1029	953	534	740	895	629	314	692
MPLDV40	in.	45 1/2	42 1/2	25 5/8	34 1/8	40 1/4	29 3/4	14 7/8	32 1/4
	mm	1156	1080	651	867	1022	756	378	819
MPLDV45	in.	45 1/2	42 1/2	25 5/8	39 1/8	45 1/4	34 3/4	17 3/8	32 1/4
	mm	1156	1080	651	994	1149	883	441	819

Figure 11

Step 3. INSTALL THE VENT SYSTEM

General Information

These instructions should be used as a guideline and do not supersede local codes in any way. Install vent according to local codes, these instructions, the current National Fuel Gas Code (ANSI-Z223.1) in the USA or the current standards of CAN/CGA-B149.1 and -B149.2 in Canada.

These fireplaces are designed, tested and listed for operation and installation with, and only with, Secure Vent™ Direct Vent System Components, Secure Flex™ Flexible Vent Components manufactured by Security Chimneys International and Z-FLEX™ Model GA Venting Systems listed to UL1777 and ULCS635 manufactured by Flexmaster Canada Limited. These approved vent system components are labeled for identification. **DO NOT use any other manufacturer's vent components with these appliances.**

These fireplaces must be vented directly to the outside.

Determine the venting for the appliance. If the vent run will include at least 8 feet of vertical rise, then install the second restrictor in the appliance collar before connecting any vent (Refer to **Figure 12**). Place the second restrictor inside the fixed restrictor.

Note: The second restrictor is included within the firebox.

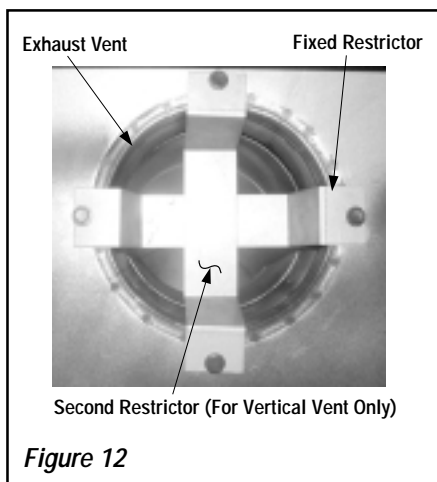

The vent system may not service multiple appliances, and must never be connected to a flue serving a solid fuel burning appliance. The vent pipe is tested to be run inside an enclosing wall (such as a chase). There is no requirement for inspection openings in the enclosing wall at any of the joints in the vent pipe.

Select Venting System - Horizontal or Vertical

With the appliance secured in framing, determine vent routing and identify the exterior termination location. The following sections describe vertical (roof) and horizontal (exterior wall) vent applications. Refer to the section relating to your installation. **A list of approved venting components is shown in the tables on page 26.**

VERTICAL TERMINATION SYSTEMS (ROOF)

Figures 13, 17 and 23 through 25 on pages 12, 14 and 15 and their associated Vertical Vent Tables illustrate the various vertical venting configurations that are possible for use with these appliances. **Secure Vent** pipe applications are shown in these figures; **Secure Flex** pipe may also be used.

A Vertical Vent Table summarizes each system's minimum and maximum vertical and horizontal length values that can be used to design and install the vent components in a variety of applications.

Both these vertical vent systems terminate through the roof. The minimum vent height above the roof and/or adjacent walls is specified in ANSI Z223.1-(latest edition) (In Canada, the current CAN-1 B149 installation code) by major building codes. Always consult your local codes for specific requirements. A general guide to follow is the Gas Vent Rule (refer to **Figure 4 on page 6**).

Vertical (Straight) Installation

Determine the number of straight vent sections required. 4-1/2" (114 mm), 10-1/2" (267 mm), 22-1/2" (572 mm), 34-1/2" (876 mm) and 46 1/2" (1181 mm) net section lengths are available. Plan the vent lengths so that a joint does not occur at the intersection of ceiling or roof joists. Refer to the Vent Section Length Chart.

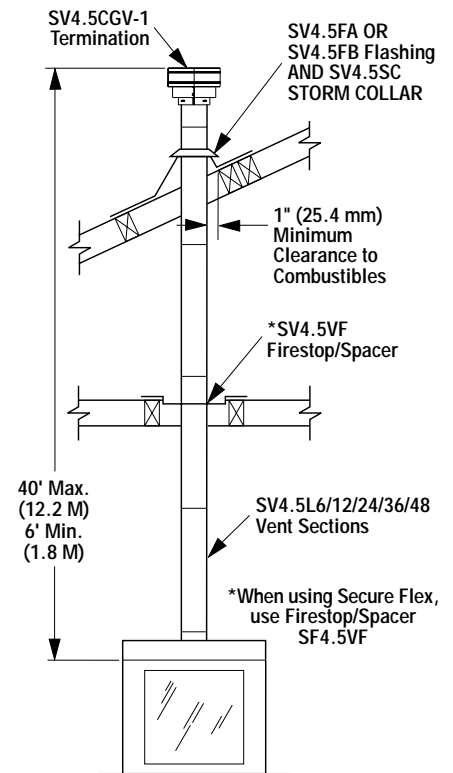

Figure 13

Vertical (Offset) Installation

Analyze the vent routing and determine the quantities of vent sections and number of elbows required. Refer to **Vertical Vent Figures and Tables on page 14 and 15** to select the type of vertical installation desired. Vent sections are available in net lengths of 4-1/2" (114 mm), 10-1/2" (267 mm), 22-1/2" (572 mm), 34-1/2" (876 mm) and 46-1/2" (1181 mm). Refer to the **Vent Section Length Chart on page 11** for an aid in selecting length combinations. Elbows are available in 90° and 45° configurations. Refer to **Figure 18** for the SV4.5E45 and SV4.5E90 elbow dimensional specifications.

VENT SECTION LENGTH CHART							T O T A L
Nominal Section Length (inches)	6	12	24	36	48	Q T Y	
Net Section Length (inches)	4-1/2	10-1/2	22-1/2	34-1/2	46-1/2		
Height of Vent	Number of Vent Sections					Q T Y	
inches	ft						
4.5	0.375	1	0	0	0	0	1
9	0.75	2	0	0	0	0	2
10.5	0.875	0	1	0	0	0	1
15	1.25	1	1	0	0	0	2
19.5	1.625	2	1	0	0	0	3
21	1.75	0	2	0	0	0	2
22.5	1.875	0	0	1	0	0	1
25.5	2.125	1	2	0	0	0	3
31.5	2.625	0	3	0	0	0	3
34.5	2.875	0	0	0	1	0	1
37.5	3.125	1	1	1	0	0	3
43.5	3.625	0	2	1	0	0	3
45	3.75	0	0	2	0	0	2
46.5	3.875	0	0	0	0	1	1
49.5	4.125	1	0	2	0	0	3
51	4.25	1	0	0	0	1	2
55.5	4.625	0	1	2	0	0	3
57	4.75	0	0	1	1	0	2
66	5.25	0	2	2	0	0	4
67.5	5.625	0	0	3	0	0	3
69	5.75	0	0	0	2	0	2
72	6	1	0	3	0	0	4
73.5	6.125	1	0	0	2	0	3
79.5	6.625	0	1	0	2	0	3
81	6.75	0	0	0	1	1	2
90	7.5	0	2	1	0	1	4
91.5	7.625	0	0	2	0	1	3
93	7.75	0	0	0	0	2	2
96	8	1	0	1	2	0	4
97.5	8.125	1	0	0	0	2	3
102	8.5	2	0	0	0	2	4
103.5	8.625	0	0	0	3	0	3
108	9	1	0	0	3	0	4
114	9.5	0	2	0	0	2	4
117	9.75	1	0	5	0	0	6
118.5	9.875	1	1	0	3	0	5
126	10.5	0	0	1	3	0	4
130.5	10.875	1	0	1	3	0	5
135	11.25	0	0	6	0	0	6
138	11.5	0	0	0	4	0	4
139.5	11.625	0	0	0	0	3	3
142.5	11.875	1	0	0	4	0	5

VENT SECTION LENGTH CHART							T O T A L
Nominal Section Length (inches)	6	12	24	36	48	Q T Y	
Net Section Length (inches)	4-1/2	10-1/2	22-1/2	34-1/2	46-1/2		
Height of Vent	Number of Vent Sections					Q T Y	
inches	ft						
144	12	1	0	0	0	3	4
150	12.5	0	1	0	0	3	4
154.5	12.875	1	1	0	0	3	5
160.5	13.375	0	2	0	0	3	5
172.5	14.375	0	0	0	5	0	5
177	14.75	1	0	0	5	0	6
183	15.25	0	1	0	5	0	6
186	15.5	0	0	0	0	4	4
190.5	15.875	1	0	0	0	4	5
196.5	16.375	0	1	0	0	4	5
205.5	17.125	0	1	1	5	0	7
207	17.25	0	0	0	6	0	6
211.5	17.625	1	0	0	6	0	7
217.5	18.125	0	1	0	6	0	7
229.5	19.125	0	0	1	6	0	7
232.5	19.375	0	0	0	0	5	5
237	19.75	1	0	0	0	5	6
241.5	20.125	0	0	0	7	0	7
246	20.5	1	0	0	7	0	8
252	21	0	1	0	7	0	8
264	22	0	0	1	7	0	8
276	23	0	0	0	8	0	8
279	23.25	0	0	0	0	6	6
280.5	23.375	1	0	0	8	0	9
283.5	23.625	1	0	0	0	6	7
289.5	24.125	0	1	0	0	6	7
301.5	25.125	0	0	1	0	6	7
310.5	25.875	0	0	0	9	0	9
315	26.5	1	0	0	9	0	10
325.5	27.125	0	0	0	0	7	7
330	27.5	1	0	0	0	7	8
336	28	0	1	0	0	7	8
345	28.75	0	0	0	10	0	10
349.5	29.125	1	0	0	10	0	11
372	31	0	0	0	0	8	8
376.5	31.375	1	0	0	0	8	9
379.5	31.625	0	0	0	11	0	11
418.5	34.875	0	0	0	0	9	9
423	35.25	1	0	0	0	9	10
465	38.75	0	0	0	0	10	10

Where required, a telescopic vent section (SV4.5LA) may be used to provide the installer with an option in installing in tight and confined spaces or where the vent run made up of fixed length pieces develops a joint in a undesirable location, or will not build up to the required length. The SV4.5LA Telescopic Vent Section has an effective length of from 1-1/2" (38 mm) to 7-1/2" (191 mm).

The SV4.5LA is fitted with a locking inclined channel end (identical to a normal vent section component) and a plain end with 3 pilot holes. Slip the plain end over the locking channel end of a standard SV4.5 vent component the required distance and secure with three #8 x 3/8" screws.

Maintain a minimum 1" (25 mm) clearance to combustible materials for all vertical vent elements.

Clearances for horizontal vent elements are 1" (25 mm) at the sides and 1" (25 mm) on the bottom. Clearances above horizontal vent elements are 3" (76 mm) for all models and all applications. *Exception: Clearance is 5" (127 mm) for MPLDV35, MPLDV40 & MPLDV45, when the center line of the horizontal run is less than 48" (1219 mm) above the fireplace top wrapper surface.*

The starter elbow may not be used if a 45 degree vent run is required directly off of the unit. Refer to *Detail - Figure 17*.

A. Attach Supplied 45 Degree Starter Elbow - Slip the plain end with 3 mounting holes over the locking channel end of the appliance collar and secure with three screws.

B. Support The Elbows - Support the starter elbow and the vertical portions of the venting system with support bracket as shown in *Figure 23 - Detail A*, on page 14. **Do not** use the starter elbow anywhere else in the vent system if not used on the appliance collar. SV4.5 rigid and flex components can be used directly off the collar. **Do not** return to rigid sections after using flex sections in a vent run.

C. Frame ceiling opening - Use a plumb line from the ceiling above the appliance to locate center of the vertical run. Cut and/or frame an opening, 10-1/2" x 10-1/2" (267mm x 267mm) inside dimensions, about this center mark (*Figure 14*).

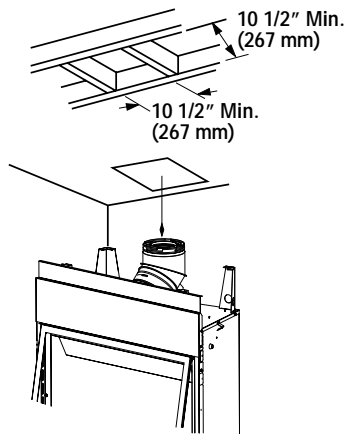

Figure 14

D. Attach vent components to 45 degree starter elbow - Secure Vent SV4.5 direct vent system components are unitized concentric pipe components featuring positive twist lock connections (see Figure 15).

All of the appliances covered in this document are fitted with collars having locking inclined channels. The dimpled end of the vent components fit over the appliance collar to create the positive twist lock connection.

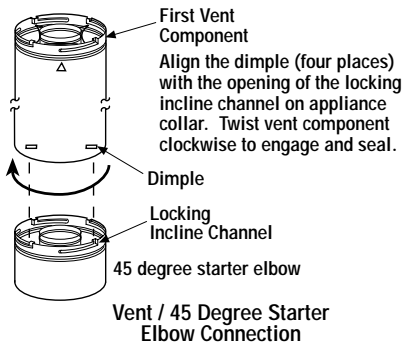

Figure 15

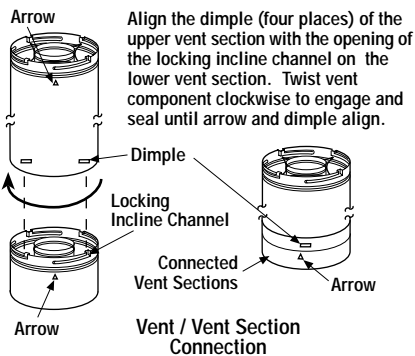

Figure 16

To attach a vent component to the 45 degree starter elbow, align the dimpled end over the elbow, adjusting the radial alignment until the four locking dimples are aligned with the inlet of the four inclined channels on the collar (refer to Figure 15).

Push the vent component against the starter elbow until it fully engages, then twist the component clockwise, running the dimples down and along the incline channels until they seat at the end of the channels.

The unitized design of the **Secure Vent** components will engage and seal both the inner and outer pipe without the need for sealant or screws. If desired a #6 x 1/2" screw may be used at the joint, but it is not required as the pipe will securely lock when twisted.

Note: Always use the starter elbow directly at the appliance 45° collar unless rigid straight pipe of flex pipe is used, as shown in Figure 17.

E. Attach vent components to each other - Other vent sections may be added to the previously installed section in accordance with the requirements of the vertical vent figures and tables. To add another vent component to a length of vent run, align the dimpled end over the inclined channel end of the previously installed section, adjusting the radial alignment until the four locking dimples are aligned with the inlets of the four incline channels of the previous section. Push the vent component against the previous section until it fully engages, then twist the component clockwise running the dimples down and along the incline channels until they seat at the end of the channels.

This seating position is indicated by the alignment of the arrow and dimple as shown in Figure 16.

F. Install firestop/spacer at ceiling - When using Secure Vent, use SV4.5VF firestop/spacer at ceiling joists; when using Secure Flex, use SF4.5VF firestop/spacer. If there is living space above the ceiling level, the firestop/spacer must be installed on the bottom side of the ceiling. If attic space is above the ceiling, the firestop/spacer must be installed on the top side of the joist.

Route the vent sections through the framed opening and secure the firestop/spacer with 8d nails or other appropriate fasteners at each corner. Remember to maintain 1" (25 mm) clearance to combustibles, framing members, and attic or ceiling insulation when running vertical chimney sections. Attic insulation shield (96K94) may be used to obtain the required clearances indicated here. See installation accessories table on page 25.

G. Support the vertical vent run sections - **Note** - Proper venting support is very important. The weight of the vent must not be supported by the fireplace in any degree.

Support the vertical portion of the venting system every 8 feet (2.4m) above the fireplace vent outlet. One method of support is by utilizing field provided support straps (conventional plumber's tape). Secure the plumber's tape to the framing members with nails or screws.

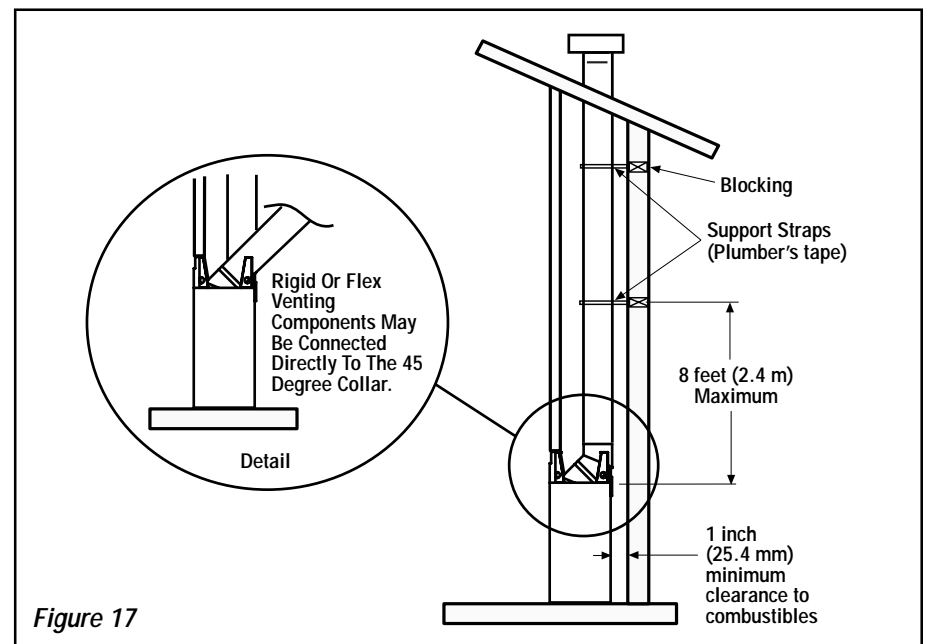

Figure 17

Loop the tape around the vent, securing the ends of the tape to the framing. If desired, sheet metal screws #6 x 1/2" length may be used to secure the support straps to the vent pipe. Refer to **Figure 17**.

H. Change vent direction to horizontal/inclined run - At transition from or to a horizontal/inclined run, install the SV4.5E45 and SV4.5E90 elbows in the same manner as the straight vent sections. The elbows feature a twist section to allow them to be routed about the center axis of their initial collar section to align with the required direction of the next vent run element. **Twist elbow sections in a clockwise direction only so as to avoid the possibility of unlocking any of the previously connected vent sections.** See **Figure 18**.

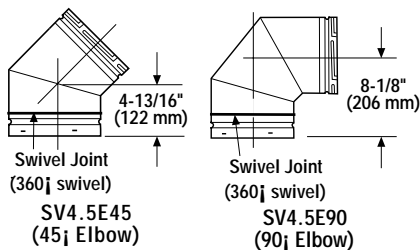

Figure 18

I. Continue installation of horizontal/inclined sections - Continue with the installation of the straight vent sections in horizontal/inclined run as described in **Step E**. Install support straps every 5' (1.52 m) along horizontal/inclined vent runs using conventional plumber's tape. **It is very important that the horizontal/inclined run be maintained in a straight (no dips) and slightly elevated plane in a direction away from the fireplace 1/4" per foot (20 mm per meter) which is ideal, though rise per foot run ratios that are smaller are acceptable all the way down to at or near level.**

It is important to maintain the required clearances to combustibles at the top and bottom for all horizontal/inclined runs.

Maintain a minimum 1" (25 mm) clearance to combustible materials for all vertical vent elements.

Clearances for horizontal vent elements are 1" (25 mm) at the sides and 1" (25 mm) on the bottom. Clearances above horizontal vent elements are 3" (76 mm) for all models and all applications. **Exception: Clearance is 5" (127 mm) for MPLDV35, MPLDV40 & MPLDV45, when the center line of the horizontal run is less than 48" (1219 mm) above the fireplace top wrapper surface.**

H. Frame roof opening - Identify location for vent at the roof. Cut and/or frame opening per Roof Framing Chart and **Figure 19**.

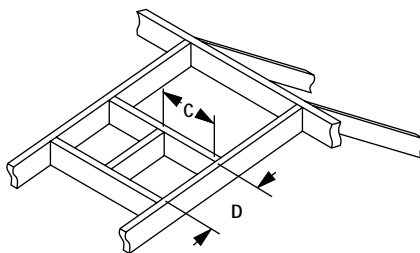

Framing Dimensions for Roof

Pitch	C	D
0/12	10-1/2 in. (267 mm)	10-1/2 in. (267 mm)
6/12	10-1/2 in. (267 mm)	12 in. (305 mm)
12/12	10-1/2 in. (267 mm)	17-3/4 in. (451 mm)

Figure 19

J. Install the roof flashing - Extend the vent sections through the roof structure. Install the roof flashing over the vent section and position such that the vent column rises vertically (use carpenter's level) (**Figure 20**). Nail along perimeter to secure flashing or adjust roofing to overlap the flashing edges at top and sides only and trim where necessary. Seal the top and both sides of the flashing with waterproof caulking.

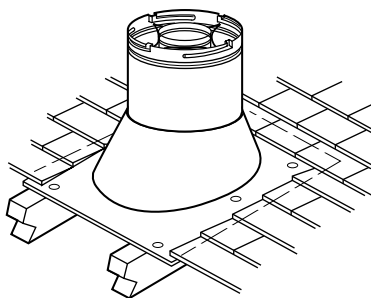

Figure 20

K. Install the storm collar - Install the storm collar, supplied with the flashing, over the vent/flashing joint. See **Figure 21**. Loosen the storm collar screw. Slide collar down until it meets the top of the flashing. Tighten the adjusting screw. Apply non-combustible caulking or mastic around the circumference of the joint to provide a water tight seal.

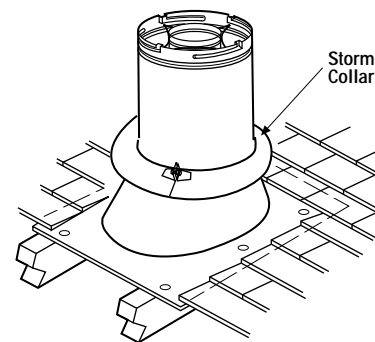

Figure 21

L. Install the vertical termination - The final step involves installation of the SV4.5CGV-1 Vertical Termination. Extend the vent sections to the height as shown in the "Vertical vent termination section" on **page 6**. The SV4.5CGV-1 Vertical Termination (**Figure 22**) installs in the exact same fashion as any other **Secure Vent** section. Align the termination over the end of the previously installed section, adjusting the radial alignment until the four locking dimples of the termination are aligned with the inlets of the four incline channels of the last vent section. Push the termination down until it fully engages, then twist the termination clockwise running the dimples down and along the incline channels until they seat at the end of the channels.

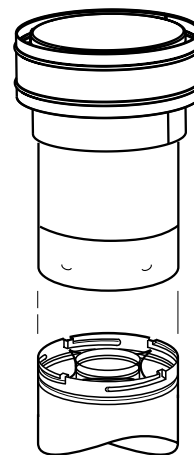

Figure 22

If the vent system extends more than 5' (1.5 m) above the roof flashing, stabilizers may be necessary. Additional screws may be used at section joints for added stability. Guide wires may be attached to the joint for additional support on multiple joint configurations.

VERTICAL VENT FIGURES/TABLES

Note: Secure Vent (rigid vent pipe) is shown in the figures; Secure Flex (flexible vent pipe) may also be used.

WARNING: UNDER NO CIRCUMSTANCES MAY SEPARATE SECTIONS OF CONCENTRIC FLEXIBLE VENT PIPE BE JOINED TOGETHER.

Note: It is very important that the horizontal/inclined run be maintained in a straight (no dips) and recommended to be in a slightly elevated plane, in a direction away from the fireplace of 1/4" rise per foot (20 mm per meter) which is ideal, though rise per foot run ratios that are smaller are acceptable all the way down to at or near level.

Note: SV4.5VF (Secure Vent), SF4.5VF (Secure Flex) firestop/spacer must be used anytime vent pipe passes through a combustible floor or ceiling. SV4.5HF (Secure Vent) or SF4.5HF (Secure Flex) must be used anytime vent pipe passes through a combustible wall. For the MPLDV35/40/45, with a center line lower than 48" (1219 mm) above the fireplace top wrapper surface, use SV4.5HF5 or SF4.5HF5. In all cases the firestop/spacer provided with the termination may be used with the termination, frame to 5" clearance where applicable.

Note: Two 45 degree elbows may be used in place of one 90 degree elbow. The same rise to run ratios, as shown in the venting figures for 90 elbows, must be followed if 45 degree elbows are used.

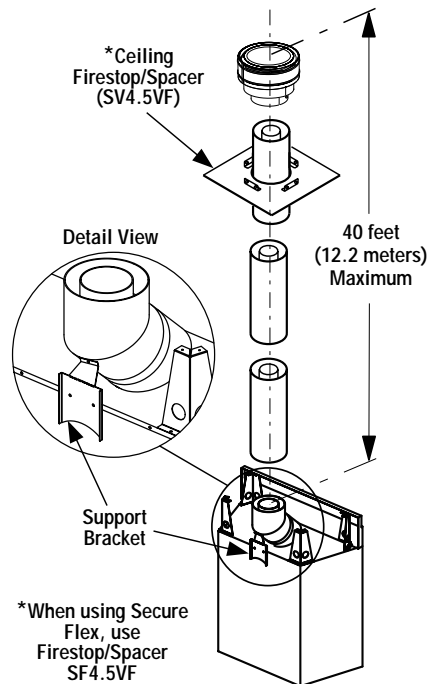

Note: Install second restrictor in any run having more than 8 ft. of vertical rise.

Figure 23 - Top Vent - STRAIGHT

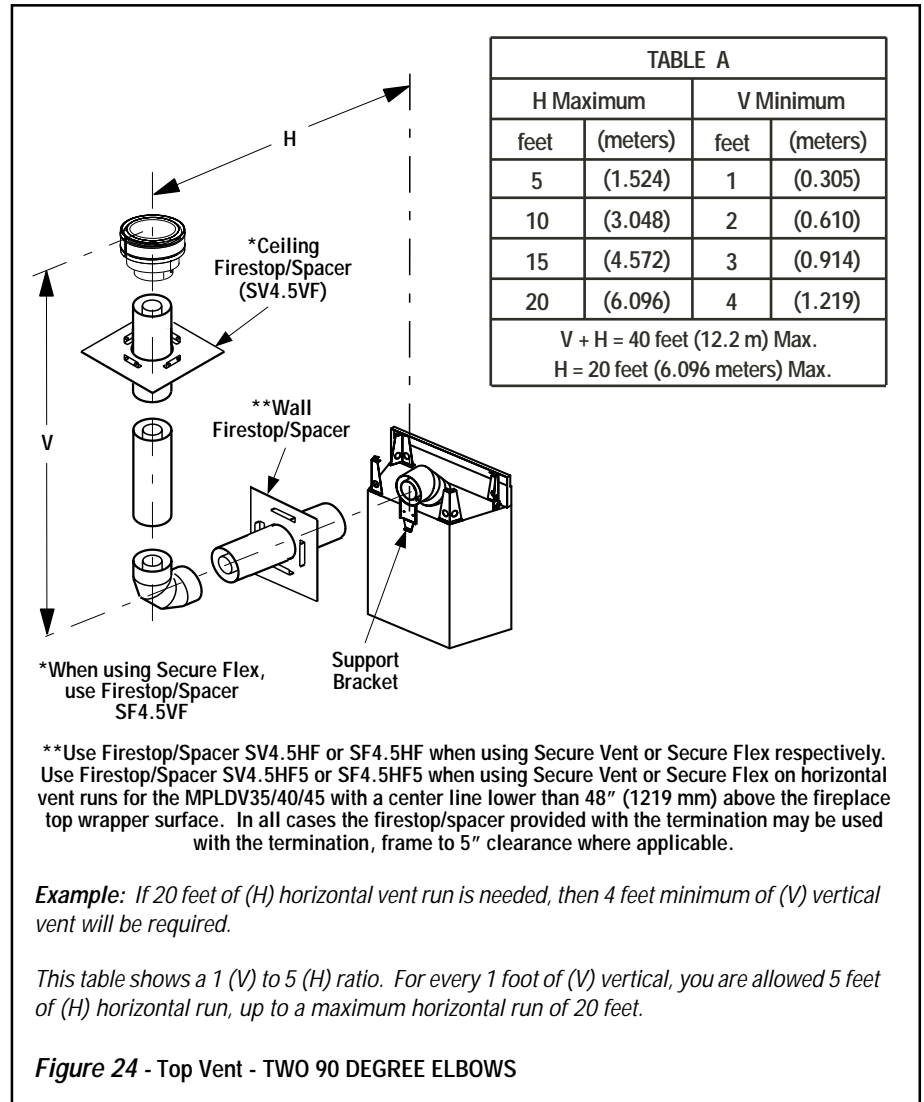

Example: If 20 feet of (H) horizontal vent run is needed, then 4 feet minimum of (V) vertical vent will be required.

This table shows a 1 (V) to 5 (H) ratio. For every 1 foot of (V) vertical, you are allowed 5 feet of (H) horizontal run, up to a maximum horizontal run of 20 feet.

Figure 24 - Top Vent - TWO 90 DEGREE ELBOWS

VERTICAL VENT FIGURES/TABLES
(continued)

TABLE B			
H + H ₁ Maximum		V Minimum	
feet	(meters)	feet	(meters)
5	(1.524)	1	(0.305)
10	(3.048)	2	(0.610)
15	(4.572)	3	(0.914)
20	(6.096)	4	(1.219)
H + H ₁ = 20 feet (6.096 m) Max.			
V + H + H ₁ = 40 ft. (12.192 m) Max.			

Example: If 20 feet of (H) horizontal vent run is needed, then 4 feet minimum of (V) vertical vent will be required.

This table shows a 1 (V) to 5 (H) ratio. For every 1 foot of (V) vertical, you are allowed 5 feet of (H) horizontal run, up to a maximum horizontal run of 20 feet.

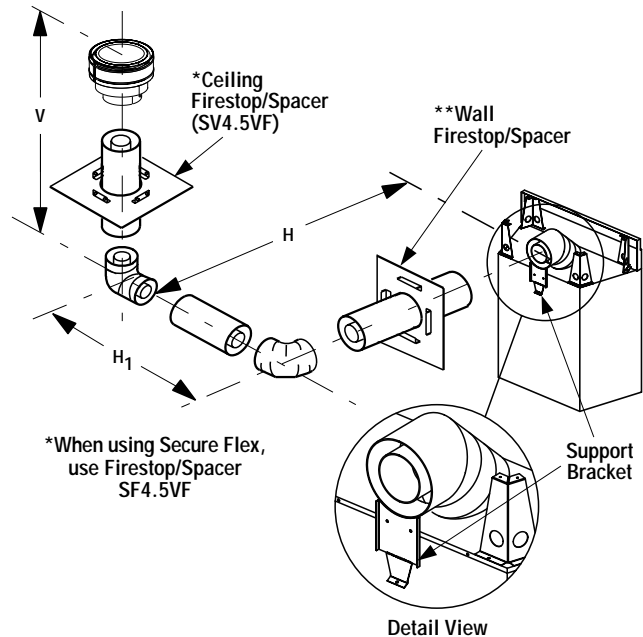

**Use Firestop/Spacer SV4.5HF or SF4.5HF when using Secure Vent or Secure Flex respectively. Use Firestop/Spacer SV4.5HF5 or SF4.5HF5 when using Secure Vent or Secure Flex on horizontal vent runs for the MPLDV35/40/45 with a center line lower than 48" (1219 mm) above the fireplace top wrapper surface. In all cases the firestop/spacer provided with the termination may be used with the termination, frame to 5" clearance where applicable.

Figure 25 - Top Vent - THREE ELBOWS

HORIZONTAL (OUTSIDE WALL) TERMINATION SYSTEM

Figures 26, and Figures 29 to 32 on pages 18 and 19 and their associated Horizontal Vent Table illustrate the various horizontal venting configurations that are possible for use with these appliances. **Secure Vent** pipe applications are shown in these figures; **Secure Flex** pipe may also be used. A Horizontal Vent Table summarizes each system's minimum and maximum vertical and horizontal length values that can be used to design and install the vent components in a variety of applications.

A. Attach Supplied 45 Degree Starter Elbow
- Slip the plain end with 3 mounting holes over the locking channel end of the appliance collar and secure with three screws.

B. Support The Elbows - Support the starter elbow and the horizontal portions of the venting system with support bracket as shown in Figure 29 to 32.

Both of these horizontal vent systems terminate through an outside wall. Building Codes limit or prohibit terminating in specific areas. Refer to Figure 8 on page 7 for location guidelines.

Secure Vent SV4.5 direct vent system components are unitized concentric pipe components featuring positive twist lock connection, (refer to Figure 15 and 16 on page 12). All of the appliances covered in this document are fitted with collars having locking inclined channels. The dimpled end of the vent components fit over the appliance collar to create the positive twist lock connection.

C. Plan the vent run -

Analyze the vent routing and determine the types and quantities of sections required 4-1/2" (114 mm), 10-1/2" (267 mm), 22-1/2" (572 mm), 34-1/2" (876 mm) and 46-1/2" (1181 mm) net section lengths are available. Plan the vent lengths so that a joint does not occur at the intersection of ceiling or roof joists. Make allowances for elbows as indicated in Figure 18 on page 13.

Maintain a minimum 1" (25 mm) clearance to combustible materials for all vertical vent elements.

Clearances for horizontal vent elements are 1" (25 mm) at the sides and 1" (25 mm) on the bottom. Clearances above horizontal vent elements are 3" (76 mm) for all models and all applications. *Exception: Clearance is 5" (127 mm) for MPLDV35, MPLDV40 & MPLDV45, when the center line of the horizontal run is less than 48" (1219 mm) above the fireplace top wrapper surface.*

D. Frame exterior wall opening -

Locate the center of the vent outlet on the exterior wall according to the dimensions shown in *Figure 9 on page 8*.

Cut and/or frame an opening, 10-1/2" x 12-1/8" (267 mm x 308mm) inside dimensions, about this center.

E. Frame ceiling opening - If the vertical route is to penetrate a ceiling, use plumb line to locate the center above the appliance. Cut and/or frame an opening, 10-1/2" x 10-1/2" (267 mm x 267 mm) inside dimensions, about this center (refer to *Figure 14 on page 11*).

F. Attach vent components to starter elbow -

To attach a vent component to the the starter elbow, align the dimpled end over the collar, adjusting the radial alignment until the four locking dimples are aligned with the inlets of the four incline channels on the collar (refer to *Figure 15 on page 12*).

Push the vent component against the elbow until it fully engages, then twist the component clockwise, running the dimples down and along the incline channels until they seat at the end of the channels. The unitized design of the **Secure Vent** components will engage and seal both the inner and outer pipe elements with the same procedure. Sealant and securing screws are not required.

Note: A 90 or 45 degree elbow may not be directly attached to the appliance elbow collar.

G. Attach vent components to each other -

Other vent sections may be added to the previously installed section in accordance with the requirements of the vent tables.

To add another vent component to a length of vent run, align the dimpled end of the component over the inclined channel end of the previously installed section, adjusting the radial alignment until the four locking dimples are aligned with the inlets of the four incline channels of the previous section.

Push the vent component against the previous section until it fully engages, then twist the component clockwise running the dimples down and along the incline channels until they seat at the end of the channels. **This seating position is indicated by the alignment of the arrow and dimple as shown in Figure 16 on page 12.**

H. Install firestop/spacer at ceiling -

When using Secure Vent, use SV4.5VF firestop/spacer at ceiling joists; when using Secure Flex, use SF4.5VF firestop/spacer.

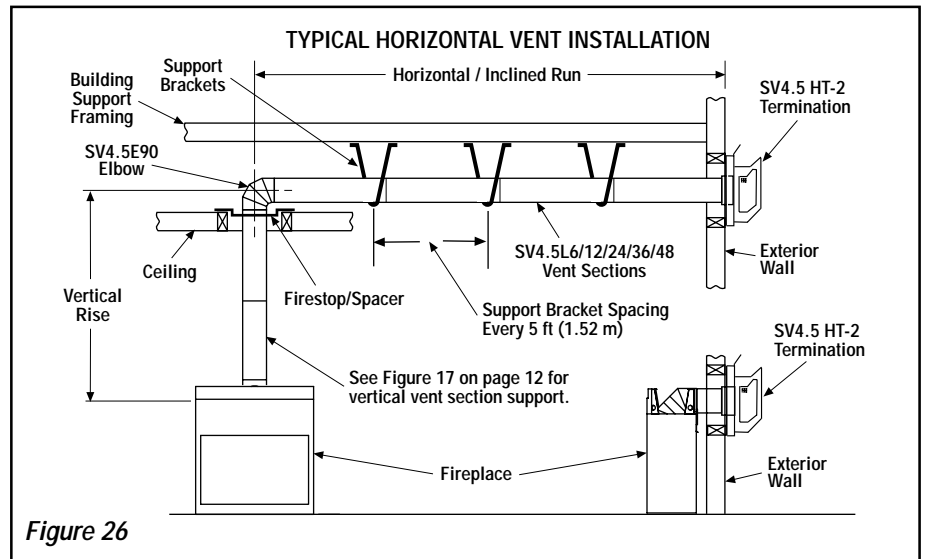

If there is living space above the ceiling level, the firestop/ spacer must be installed on the bottom side of the ceiling. If attic space is above the ceiling, the firestop/ spacer must be installed on the top side of the joist. Route the vent sections through the framed opening and secure the firestop/spacer with 8d nails or other appropriate fasteners at each corner.

Remember to maintain 1" (25 mm) clearance to combustibles, framing members, and attic or ceiling insulation when running vertical chimney sections.

I. Support the vertical run sections -

On the vertical run, support the venting system every 8 feet (2.4m) above the fireplace vent outlet with field provided support straps (Plumber's tape).

Attach the straps to the vent pipe and secure to the framing members with nails or screws. See *Figure 17 on page 12*.

J. Change vent direction - At transition from or to a horizontal/inclined run, install the SV4.5E45 and SV4.5E90 elbows in the same manner as the straight vent sections. The elbows feature a twist section to allow them to be routed about the center axis of their initial collar section to align with the required direction of the next vent run element. **Twist elbow sections in a clockwise direction only so as to avoid the possibility of unlocking any of the previously connected vent sections.** See *Figure 18 on page 13*.

K. Continue installation of horizontal/inclined sections - Continue with the installation of the straight vent sections in horizontal/inclined run as described in **Step F**.

Install support straps every 5 ft. (1.52 m) along horizontal/inclined vent runs using conventional plumber's tape. See *Figure 26*, it is very important that the horizontal/inclined run be maintained in a straight (no dips) and recommended to be in a slightly elevated plane, in a direction away from the fireplace of 1/4" rise per foot (20 mm per meter) which is ideal, though rise per foot run ratios that are smaller are acceptable all the way down to at or near level. Use a carpenter's level to measure from a constant surface and adjust the support straps as necessary.

It is important to maintain the required clearances to combustibles at the top and bottom for all horizontal/inclined runs.

Maintain a minimum 1" (25 mm) clearance to combustible materials for all vertical vent elements.

Clearances for horizontal vent elements are 1" (25 mm) at the sides and 1" (25 mm) on the bottom. Clearances above horizontal vent elements are 3" (76 mm) for all models and all applications. **Exception: Clearance is 5" (127 mm) for MPLDV35, MPLDV40 & MPLDV45, when the center line of the horizontal run is less than 48" (1219 mm) above the fireplace top wrapper surface.**

L. Assemble vent run to exterior wall - If not previously measured, locate the center of the vent at the exterior wall. Prepare an opening as described in **Step D**. Assemble the vent system to point where the terminus of the last section is within 7 in. (178 mm) to 11-1/4 in. (286 mm) inboard of the exterior surface to which the SV4.5 HT-2 termination is to be attached, see *Figure 28*.

If the terminus of the last section is not within this distance, use the **telescopic vent section SV4.5LA**, as the last vent section. For wall thicknesses greater than that shown in **Figure 28**, refer to **Table 3 on page 18**. This table lists the additional venting components needed (in addition to the termination and adapter) for a particular range of wall thicknesses.

M. Attach termination adapter - Attach the adapter (SV4.5RCH - provided with the termination) to the vent section or telescoping vent section, elbow as shown in **Figure 27** in the same manner as any SV4.5 vent component (refer to **Step F**).

N. Install Firestop/Spacer at exterior wall - When using the square termination, install the SV4.5HF (Secure Vent) or SF4.5HF (Secure Flex) Firestop/Spacer over the opening at the exterior side of the framing (long side up) as shown in **Figure 27**, and fasten into place. Ensure 5" clearance is maintained by framing above the vent run for MPLDV35/40/45 when center line of the run is lower than 48" (12119 mm) above the fireplace top wrapper surface.

(The Firestop/Spacer may also be installed over the opening at the interior side of the framing.)

O. Install the desired termination -

1. Install the square termination (SV4.5HT-2) - For the last step, from outside the exterior wall, slide the collars of the termination onto the adapter (the outer over the outer and the inner inside the inner) until the termination seats against the exterior wall surface to which it will be attached. Orient the housing of the termination with the arrow pointed upwards. Secure the termination to the exterior wall. **The horizontal termination must not be recessed into the exterior wall or siding** by more than the 1-1/4" (32 mm) as shown in **Figure 28**.

SVHRK Snorkel Cap -The snorkel cap is designed to be fitted into a basement window box. The SVHRK cap is for use with flex vent. The vertical distance between the inlet and outlet of the cap is 28 in. (711 mm). pipe.

IMPORTANT: The vent termination is hot while in operation and for a period of time following use of the fireplace. To prevent contact with hot surfaces, we recommend the use of a Termination Guard. This can be purchased at your local dealer.

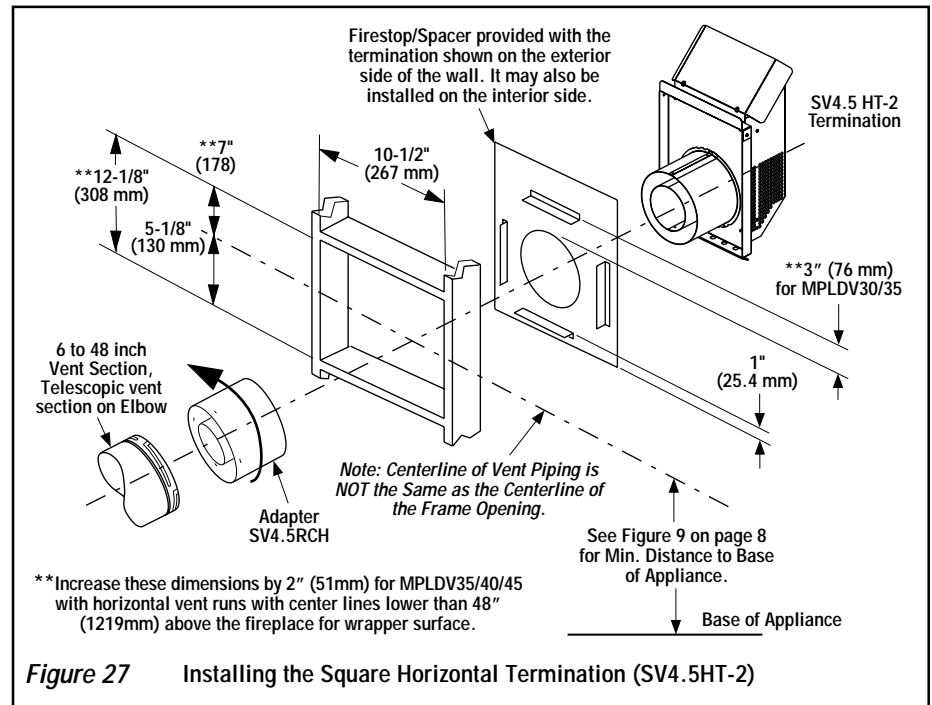

Figure 27 Installing the Square Horizontal Termination (SV4.5HT-2)

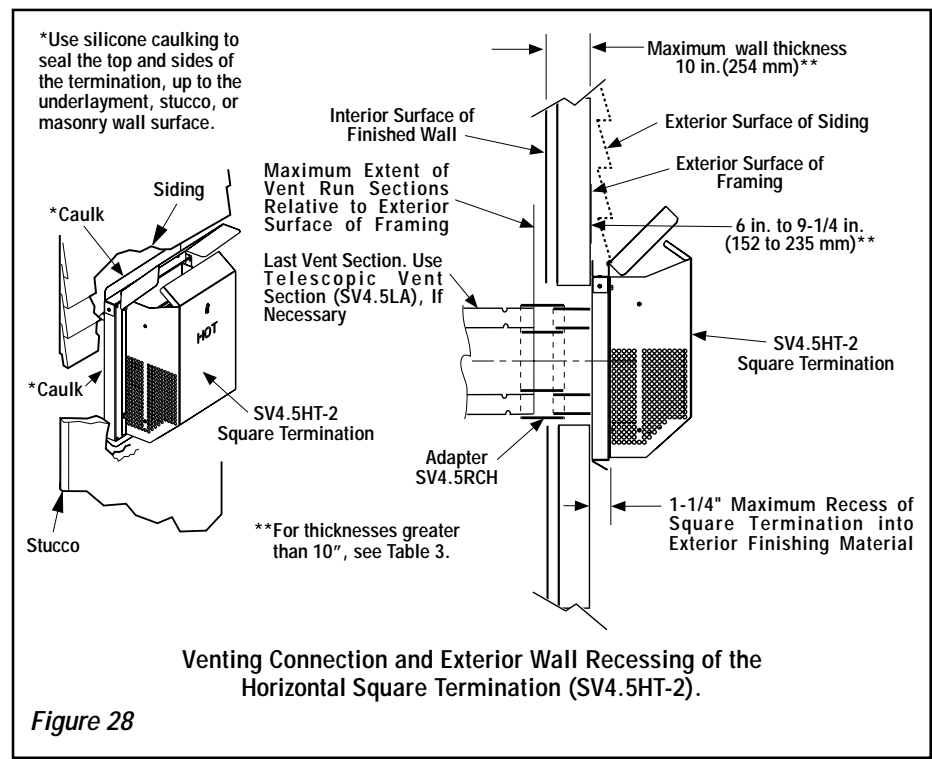

Figure 28

Horizontal terminations have been designed to perform in a wide range of weather conditions. Our terminations meet or exceed industry standards.

When selecting the locations of your horizontal terminations, do not place the termination where water from eaves and adjoining rooflines may create a heavy flow of cascading water onto the termination cap. If the cap must be placed where the possibility of cascading water exists, it is the responsibility of the builder to direct the water away from the termination cap by using gutters or other means.

Take care to carefully follow the installation instructions for the termination, including the use of silicone caulking where required.

NOTE: DIAGRAMS & ILLUSTRATIONS NOT TO SCALE.

HORIZONTAL VENT FIGURES/TABLES

Note: *Secure Vent* components (rigid vent pipe and terminal) are shown in the figures; *Secure Flex* components (flexible vent pipe and terminal) may also be used.

Note: Two 45 degree elbows may be used in place of one 90 degree elbow. The same rise to run ratios, as shown in the venting figures for 90 degree elbows, must be followed if 45 degree elbows are used.

Note: It is very important that the horizontal/inclined run be maintained in a straight (no dips) and recommended to be in a slightly elevated plane, in a direction away from the fireplace of 1/4" rise per foot (20 mm per meter) which is ideal, though rise per foot run ratios that are smaller are acceptable all the way down to at or near level.

Note: SV4.5VF (*Secure Vent*), SF4.5VF (*Secure Flex*) firestop/spacer must be used anytime vent pipe passes through a combustible floor or ceiling. Lennox MPLDV35"/40" & 45" models require 5" clearances to combustibles above horizontal vent runs when the centerline of the horizontal vent run is at or below 48" (1219 mm) above the fireplace top wrapper. In all other instances, with these three models and with the MPLDV30 in all instances, the clearance to combustibles above horizontal vent runs is 3". Please note that to facilitate the 5" clearance when required, we have two 5" clearance firestops. The SV4.5HF5 is for use with rigid (*Secure Vent*[™]) and the SF4.5HF5 is for use with (*Secure Flex*[™]). These firestops should be used whenever horizontal vent runs meeting the use requirements detailed above, penetrate walls separating occupied rooms in a house.

Each of our horizontal terminations are shipped with a standard 3" clearance horizontal firestop. In ALL cases this firestop may be used at the exterior wall regardless of any circumstances that may require the 5" clearance to combustibles above the horizontal vent component. The firestop provided with the termination is not specific for use with any particular clearance height.

The SV4.5HF or SF4.5HF firestop provided with each termination can be used as shown in **Figure 29** when fitted at the exterior wall adjacent to the termination.

WARNING: UNDER NO CIRCUMSTANCES MAY SEPARATE SECTIONS OF CONCENTRIC FLEXIBLE VENT PIPE BE JOINED TOGETHER.

Venting Components Required	Exterior Wall Thickness inches (mm)
Termination Kit Only	6 to 9-1/4 (152 to 235)
Termination Kit and 6 in. Vent Section (SV4.5L6)	10-1/2 to 13-3/4 (267 to 349)
Termination Kit and 12 in. Vent Section (SV4.5L12)	16-1/2 to 19-3/4 (419 to 502)
Termination Kit and Telescopic Section (SV4.5LA 2 to 7-12 in.) & 6 in. vent section (SV4.5L6)	11 to 19-3/4 (279 to 502)

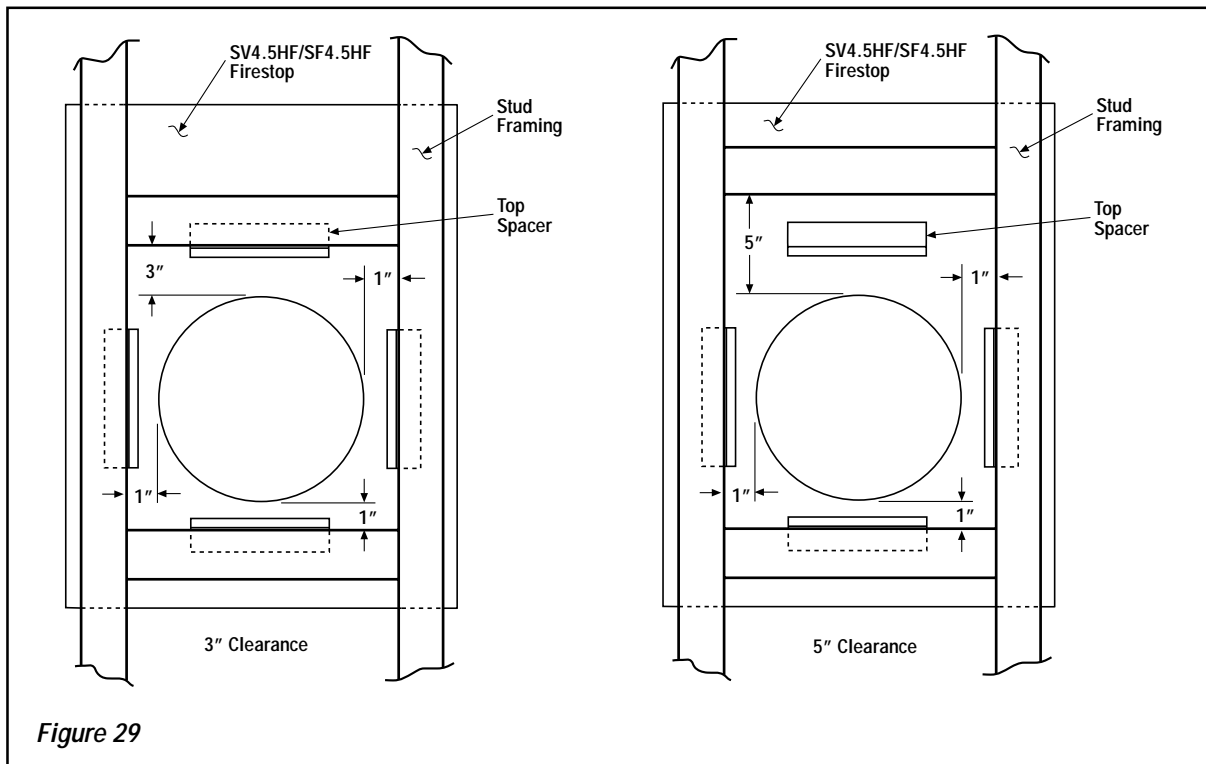

NOTE: DIAGRAMS & ILLUSTRATIONS NOT TO SCALE.

H Maximum		V Minimum	
feet	(meters)	feet	(meters)
5	(1.524)	1	(0.305)
10	(3.048)	2	(0.610)
15	(4.572)	3	(0.914)
20	(6.096)	4	(1.219)

V + H = 40 feet (12.2 m) Max.
H = 20 ft. (6.096 m) Max.

Example: If 20 feet of (H) horizontal vent run is needed, then 4 feet minimum of (V) vertical vent will be required.

This table shows a 1 (V) to 5 (H) ratio. For every 1 foot of (V) vertical, you are allowed 5 feet of (H) horizontal run, up to a maximum horizontal run of 20 feet.

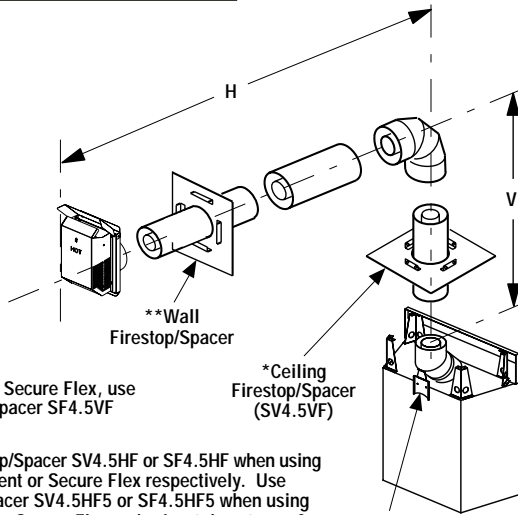

*When using Secure Flex, use Firestop/Spacer SF4.5VF

*Ceiling Firestop/Spacer (SV4.5VF)

**Use Firestop/Spacer SV4.5HF or SF4.5HF when using Secure Vent or Secure Flex respectively. Use Firestop/Spacer SV4.5HF5 or SF4.5HF5 when using Secure Vent or Secure Flex on horizontal vent runs for the MPLDV35/40/45 with a center line lower than 48" (1219 mm) above the fireplace top wrapper surface. In all cases the firestop/spacer provided with the termination may be used with the termination, frame to 5" clearance where applicable.

Square termination (SV4.5HT-2) shown.

See **Table 3** as an aid in venting component selection for a particular range of exterior wall thicknesses.

Figure 30 - Top Vent - ONE 90 DEGREE ELBOW - ELBOW CONNECTION NOT DIRECTLY AT APPLIANCE

*Use Firestop/Spacer SV4.5HF or SF4.5HF when using Secure Vent or Secure Flex respectively. Use Firestop/Spacer SV4.5HF5 or SF4.5HF5 when using Secure Vent or Secure Flex on horizontal vent runs for the MPLDV35/40/45 with a center line lower than 48" (1219 mm) above the fireplace top wrapper surface. In all cases the firestop/spacer provided with the termination may be used with the termination, frame to 5" clearance where applicable.

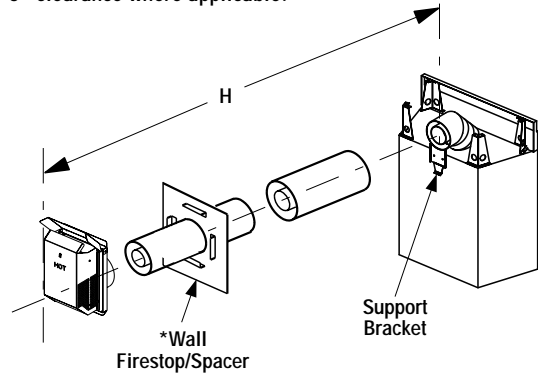

H = 28 inches (711 mm) Maximum

Square termination (SV4.5HT-2) shown.

Figure 31 - Top Vent - ONE 90 DEGREE ELBOW - CONNECTION DIRECTLY AT APPLIANCE

HORIZONTAL VENT FIGURES/TABLES (CONTINUED)

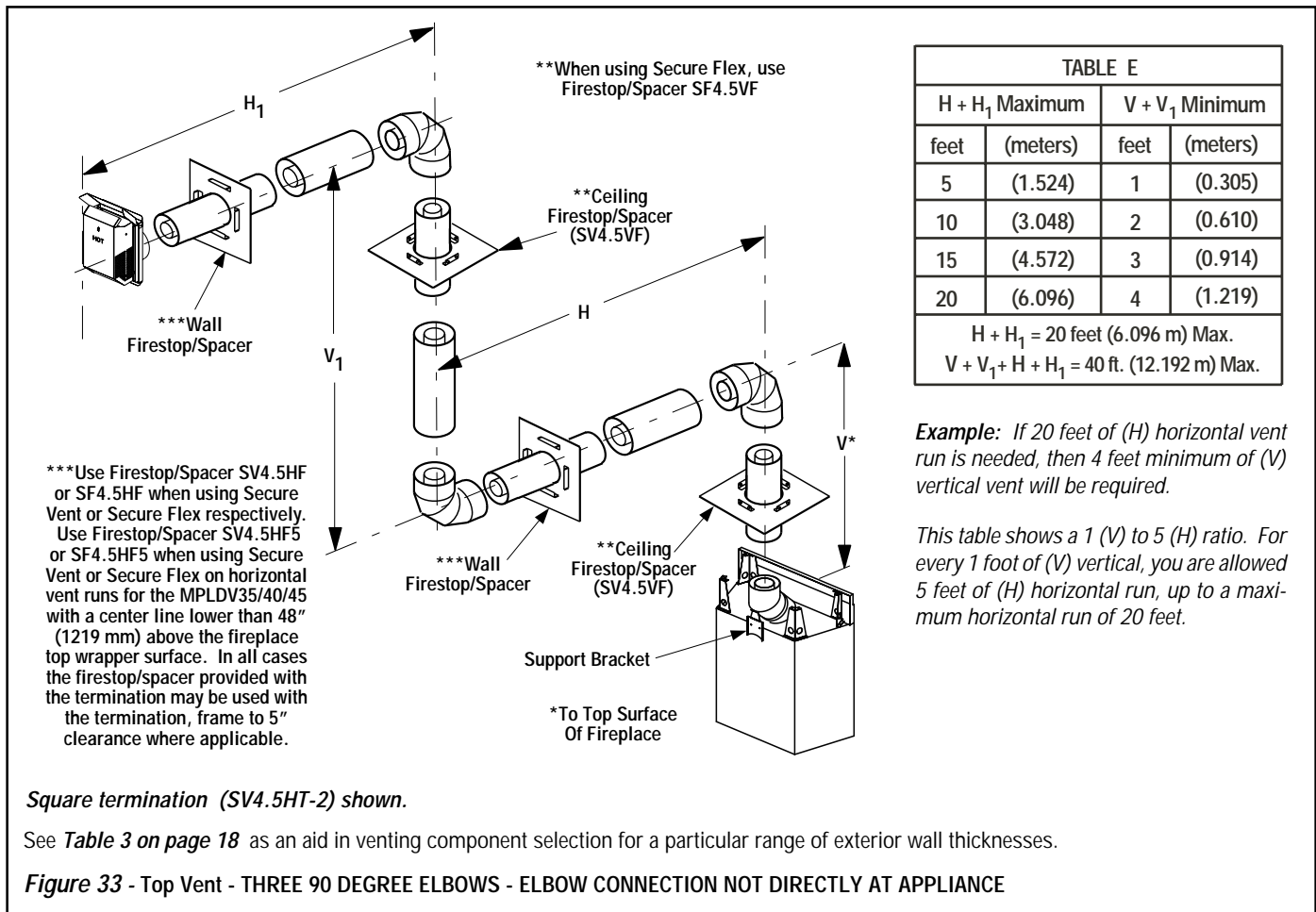
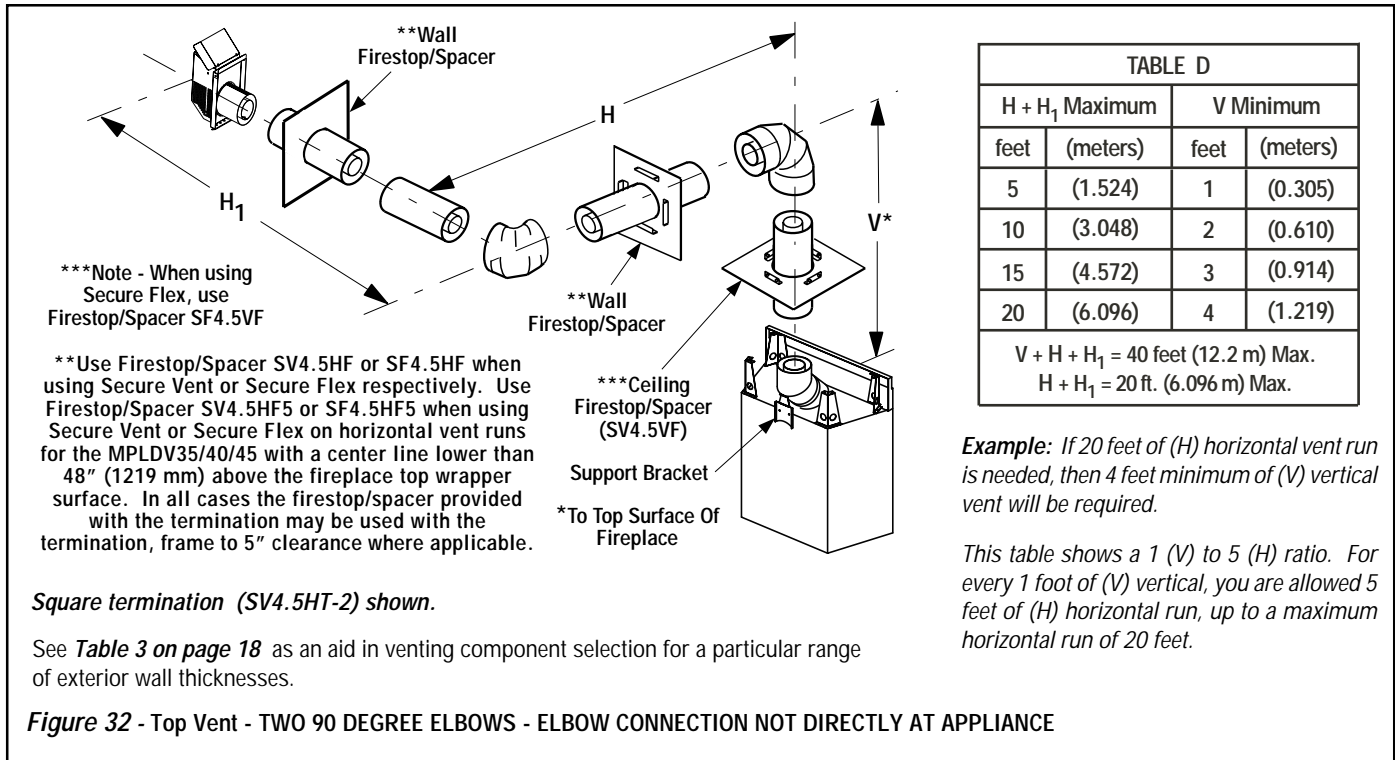

VERTICAL OR HORIZONTAL VENTING USING SECURE FLEX KITS AND COMPONENTS

Secure Flex venting kits and components may be used in any venting application where rigid Secure Vent (SV4.5) direct vent components can be used. All restrictions, clearances and allowances that pertain to the rigid piping apply to the flexible venting. **Secure Flex kits may not be modified; also, under no circumstances may separate sections of flex pipe be joined together.** Secure Flex kits may be added to the end of a vent run made up of rigid Secure Vent (SV4.5) vent sections provided that doing so does not violate any of the venting length, height, routing, horizontal to vertical ratio requirements or clearance considerations detailed in this manual.

Secure Flex kits come with an included adapter that can be fitted to the appliance collar or the inclined channel end of the last Secure Vent (SV4.5) vent section in a rigid system in the exact same fashion as any other Secure Vent section. Align the dimpled end of the adapter over the previously installed section or appliance collar, adjusting the radial alignment until the four locking dimples of the adapter are aligned with the inlets of the four incline channels of the last vent section or collar. Push on the adapter until it fully engages, then twist the adapter clockwise running the dimples down and along the incline channels until they seat at the end of the channels.

Attach the flexible vent to the adapter as follows (also see Figure 34):

A. Install the Inner Flex Pipe -

1. Install the small gear clamp loosely around the inner flexible vent pipe, push it back out of the way.
2. Apply a bead of **Mill-Pac Black (700°F) high temperature sealant - Catalog No. 10K81** to the inner adapter collar, approximately 1/2 inch from the end.
3. Pull and extend the inner flexible vent pipe.
4. Slide the inner flex pipe over the adapter collar. Ensure the flexible vent pipe completely engages the adapter collar to a distance of 1 3/4 inches from the end, and that it is free from damage or tears.
5. Slide the gear clamp down and tighten it fully to secure the flexible vent to the adapter inner collar approximately 3/4 inch from the end of the flex.
6. Install **three screws 120 degrees apart** through the flexible vent pipe and into the adapter collar just below the gear clamp to provide additional security to the connection.

B. Install the Outer Flex Pipe -

1. Install the large gear clamp loosely around the outer flexible vent pipe, push it back out of the way.

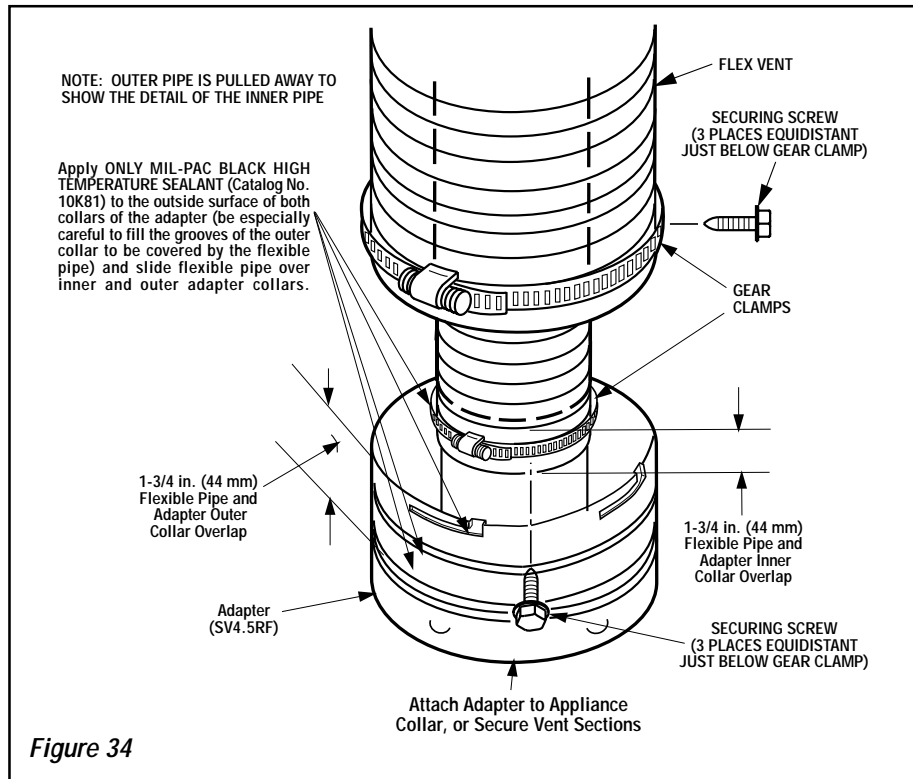

Figure 34

2. Apply a bead of **Mill-Pac Black (700°F) high temperature sealant - Catalog No. 10K81** to the outer adapter collar; to the grooves of the collar which extend approximately 1 inch from the end and to the flat surface, approximately 1-3/8 inches from the end.
3. Pull and extend the outer flexible vent pipe.
4. Slide the outer flex pipe over the adapter collar. Ensure the flexible vent pipe completely engages the adapter collar to a distance of 1-3/4 inches from the end, and that it is free from damage or tears.
5. Slide the gear clamp down and tighten it fully to secure the flexible vent to the adapter outer collar approximately 3/4 inch from the end of the flex.
6. Install **three screws 120 degrees apart** through the flexible vent pipe and into the adapter collar just below the gear clamp to provide additional security to the connection.

C. Route Flex Vent -

Ensure that the flex vent is properly routed to provide the required clearance. Do Not allow the flexible vent to bend in a radius tighter than 5" (127 mm). Refer to **Figure 35**. Support horizontal sections of flex with metal straps at 2 foot (0.61 m) intervals.

D. Install Firestop/Spacers at ceilings and walls - When Secure Flex penetrates a wall or ceiling, a firestop/spacer is required: use SV4.5 (Secure Vent), SF4.5 (Secure Flex) firestop/spacer anytime vent pipe passes through a combustible floor or ceiling.

SV4.5HF (Secure Vent) or SF4.5HF (Secure Flex) must be used anytime vent pipe passes through a combustible wall. For the MPLDV35/40/45 with a center line lower than 48" (1219 mm) above the fireplace top wrapper surface use SV4.5HF5 or SV4.5HF5. In all cases the firestop/spacer provided with the termination may be used with the termination, frame to 5" clearance where applicable.

See the appropriate sections and figures shown throughout the venting section for their installation requirements.

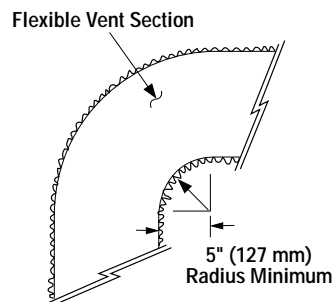

Figure 35

E. Attach Flex Vent to Termination - Secure Flex components can be purchased separately and attached to bulk lengths of Secure Flex flexible tubing cut to size at the job site. Secure the flexible vent to the Secure Flex terminations in the same manner (see **Figure 34**) as it was attached to the adapter.

Note: *Secure Flex* vent must be attached to *Secure Flex* terminations only. DO NOT substitute *Secure Vent* terminations or the *Secure Vent* adapter for *Secure Flex* components. The collars of *Secure Flex* terminations and adapters have a different circumference than that used with the *Secure Vent* pipe. Additionally, *Secure Flex* components have an extended length center tube for use in attaching the flexible vent.

Step 4. FIELD WIRING

Caution: Label all wires prior to disconnection when servicing controls. Wiring errors can cause improper and dangerous operation. Verify proper operation after servicing.

Refer to Section A for millivolt appliances and Section B for electronic appliances. The gas valve is set in place and pre-wired at the factory on both models.

A. Millivolt Wiring (See Figure 36) –

1. Appliance-mounted ON/OFF burner control switch (rocker switch) is factory installed behind the bottom panel. Optional wall-mounted switch, thermostat, or one of the optional remote control kits may also be used.

2. If wall-mounted ON/OFF control or thermostat is selected mount it in a convenient location on a wall near the fireplace.

3. Wire the control switch within the millivolt control circuit using the 15 feet of 2 conductor wire supplied with the unit.

Note: The supplied 15 feet of 2 conductor wire has one end of each conductor connected to the gas valve circuit and the other end of each conductor placed loose inside the bottom compartment.

Caution: Do Not connect the optional wall switch to a 120V power supply.

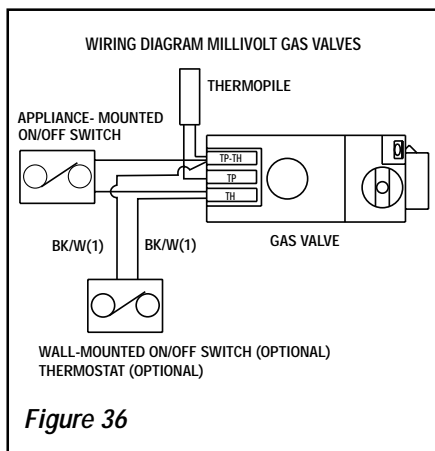

Figure 36

4. If an optional control switch is installed, turn the appliance-mounted ON/OFF burner control switch to the OFF position.

B. Electronic Wiring (See Figure 37) –

Note: The electronic appliance must be connected to the main power supply.

1. Route a 3-wire 120Vac 60Hz 1ph power supply to the appliance junction box.

2. Remove the electrical inlet cover plate from the side of the unit by removing the plate's securing screws. See Figure 11 on page 9.

3. Remove the cover plate's knockout and then feed the power supply wire through the knockout opening and into the unit junction box.

4. Connect the black power supply wire to the lower outlet's red pigtail lead and the white power supply wire to the common terminal of the outlet as shown in Figure 37.

5. Connect the ground supply wire to the pigtail lead attached to outlet's green ground screw.

6. Appliance-mounted ON/OFF burner control switch (rocker switch) is factory installed behind the bottom panel.

Optional wall-mounted switch, thermostat, or one of the optional remote control kits may also be used. The appliance mounted ON/OFF switch needs to be relocated onto the optional style view door, if used.

7. If wall-mounted ON/OFF control or thermostat is to be used, mount it in a convenient location on a wall near the fireplace.

8. If an optional control is to be used, wire it in the low voltage circuit as shown in Figure 37.

Note: The supplied 15 feet of 2 conductor wire has one end of each conductor connected to the gas valve circuit and the other end of each conductor placed loose inside the bottom compartment.

9. If an optional control switch is installed, turn the appliance-mounted ON/OFF burner control switch to the OFF position.

10. After the wiring is complete, replace the cover plate.

Note: No batteries to be installed in the battery holder until a power outage, or if the appliance is to be operated solely with two (2) "D" batteries.

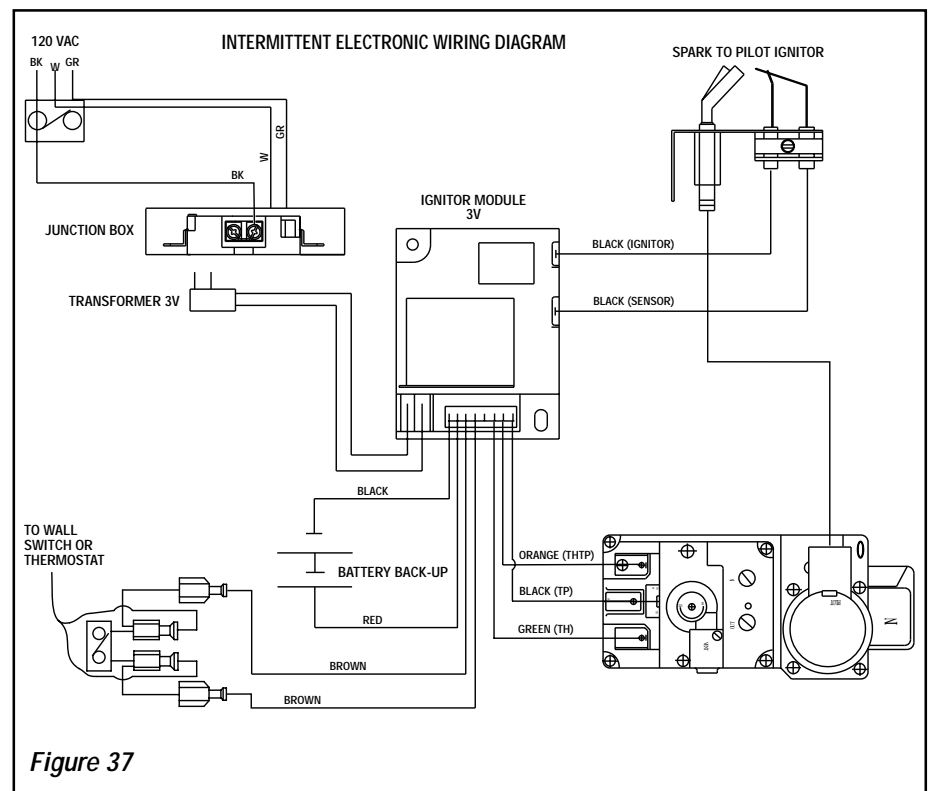

Figure 37

IMPORTANT: Ground supply lead must be connected to the wire attached to the green ground screw located on the outlet box. See *Figure 37*. Failure to do so will result in a potential safety hazard. The appliance must be electrically grounded in accordance with local codes or, in the absence of local codes, the National Electrical Code, ANSI/NFPA 70- (latest edition). (In Canada, the current CSA C22-1 Canadian Electrical Code.)

Step 5. CONNECTING GAS LINE

All codes require a shut-off valve mounted in the supply line. The orientation of the shut-off valve should face the front, as shown in *Figure 39*. *Figure 38* illustrates the method for connecting the gas supply.

The flex-line method is acceptable in the U.S., however, Canadian requirements vary depending on locality. Installation must be in compliance with local codes.

These appliances are equipped with a gas flex line for use in connecting the unit to the gas line. A gas flex line is provided to aid in attaching the direct vent appliance to the gas supply.

The gas flex line can only be used where local codes permit. See *Figure 38* for flex line description. The flex line is rated for both natural and propane gas. A manual shut off valve is also provided with the flex line.

The gas control valve is located in the lower control compartment.

Gas Line Access Plate Not Installed At The Factory. It Is Included In The Installation Instruction Bag.

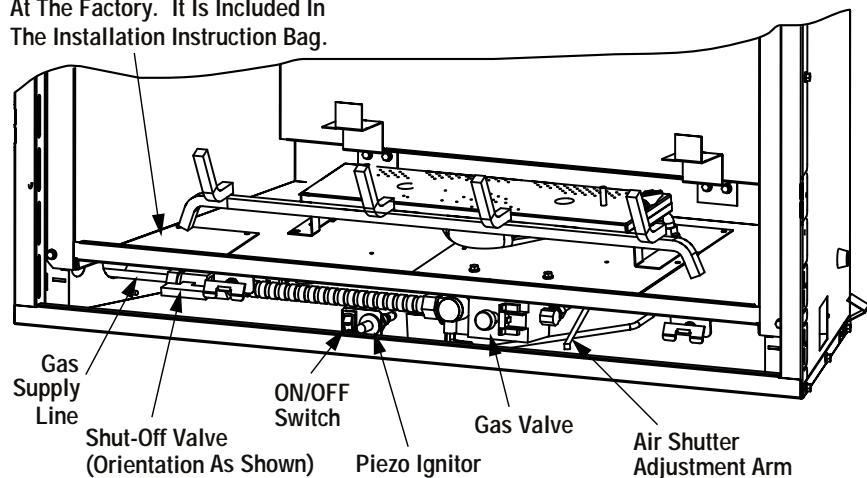

Figure 39

These appliances come from the factory with the gas line access plate removed to provide full access to the end of the gas flex line.

As designed, the glass door needs to be opened to access the open gas access area. Route a hard pipe from the left to a spot directly below the access plate opening.

Bring the shutoff valve on the end of the flex line over to the hard pipe and tighten with wrenches from above through the firebox opening.

If required, access the valve by removing the lower control compartment panel (see *Figure 39*) by lifting and pulling the panel forward. The millivolt and electronic control valve has a 3/8" (10 mm) NPT thread inlet port.

Secure all joints tightly using appropriate tools and sealing compounds (ensure propane resistant compounds are used in propane applications).

Turn on gas supply and test for gas leaks, using a gas leak test solution (also referred to as bubble leak solution).

Note: Using a soapy water solution (50% dish soap, 50% water) is an effective leak test solution but it is not recommended, because the soap residue that is left on the pipes/fittings can result in corrosion over time. **Never use an open flame to check for leaks.**

A. Light the appliance (refer to the lighting instructions label in the control compartment or in the Homeowner's Care and Operation Instructions).

B. Brush all joints and connections with the gas leak test solution to check for leaks. If bubbles are formed, or gas odor is detected, turn the gas control knob to the "OFF" position. Either tighten or refasten the leaking connection and retest as described above.

C. When the gas lines are tested and leak free, be sure to rinse off the leak testing solution.

D. When the gas lines are tested and leak free, observe the individual tongues of flame on the burner. Make sure all ports are open and producing flame evenly across the burner. If any ports are blocked, or partially blocked, clean out the ports.

Flex Line Connector

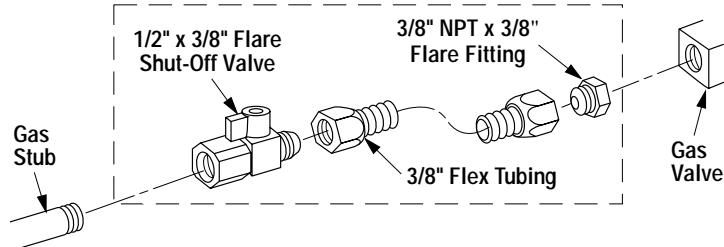

Figure 38 - GAS CONNECTION

Step 6. INSTALLING THE LOGS, GLOWING EMBERS AND VOLCANIC STONES

Remove the gas line access plate and gasket from the provided plastic bag and install them over the opening, using the provided screws (4) as shown in *Figure 39*.

Refer to *Figure 43* and loosen the set screw for the venturi air shutter. Manually actuate the air shutter through several cycles. Set the air shutter to 3/32" before placing the logs.

The logs are packaged in a carton located within the firebox. One plastic bag of glowing embers and volcanic stones are located in the bottom compartment. Refer to the **Log Set Placement Supplement** for detailed placement instructions for the logs, glowing embers and volcanic stones.

Proper log and twig placement is critical to encourage outstanding flame appearance and prevent sooting. These fires are designed to provide a rich orange/red glow on the logs. Ensure the bottom of the rear log is fully seated and pulled as far forward as the pins will allow. Refer to the **Log Set Placement Supplement** for detailed instructions.

Note: Log setup is by design asymmetric. The fire is intentionally positioned off center to provide a natural fire look.

Step 7. CHECKING APPLIANCE OPERATION

With gas line installed run initial system check-out before closing up the front of the unit. Follow the pilot lighting instructions provided in the Homeowner's Care and Operation Instructions. For piezo ignitor location see *Figure 39 on page 23* (millivolt appliances only).

Note: Lighting Instructions are also found on the literature tag tied to the gas piping next to the gas valve. To access the tag, open the lower control compartment door (Figure 39 on page 23) by pulling the panel forward.

When first lighting the appliance, it will take a few minutes for the line to purge itself of air. Once purging is complete, the pilot and burner will light and operate as indicated in the instruction manual. Subsequent lighting of the appliance will not require such purging. Inspect the pilot flame (remove logs, if necessary, handling carefully).

Millivolt Appliance Checkout

The pilot flame should be steady, not lifting or floating. Flame should be blue in color with traces of orange at the outer edge.

The top 3/8" (10 mm) at the pilot generator (thermopile) and the top 1/8" min (tip) of the quick drop out thermocouple should be engulfed in the pilot flame.

The flame should project 1" (25 mm) beyond the hood at all three ports (*Figure 40*). Replace logs if removed for pilot inspection.

To light the burner; turn "ON" the remote wall switch and rotate the gas valve control knob counterclockwise to the "ON" position ("ON" will be at the bottom side of the valve).

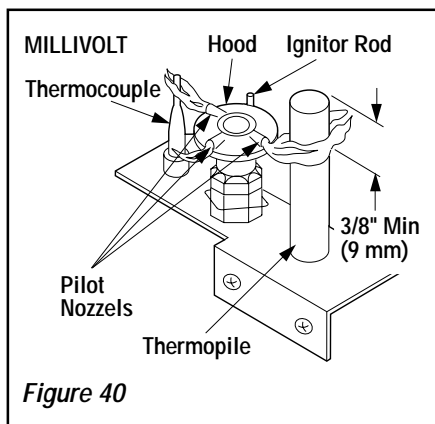

Figure 40

Electronic Appliance Checkout

To light the burner, turn 'ON' the unit mounted On/Off switch or the optional remote wall switch. Ensure the ignitor lights the pilot. The pilot flame should engulf the flame rod as shown in *Figure 41*.

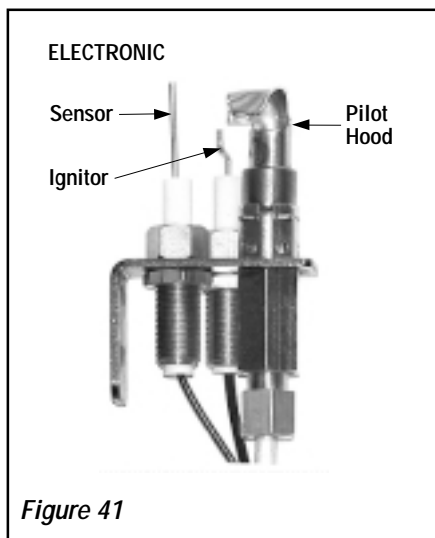

Figure 41

Step 8. INSTALLING THE GLASS DOOR AND OPTIONAL HOOD

To access the glass door securing latches, first open the lower control compartment door (*Figure 42*) by lifting and pulling the bottom panel forward.

Retrieve the glass door. Visually inspect the gasket on the backside of the frame. Gasket surface must be clean, free of irregularities and seated firmly.

Position the door in front of the firebox opening with the bottom of the door held away from the fireplace (*Figure 42*). Hook the top flange of the door frame over the top of the firebox frame. Let the bottom of the door frame swing gently in towards the fireplace ensuring that the gasket seats evenly as the door frame draws shut. Fasten the two latches located underneath the firebox floor to the door's vee-flange. Close both the latches securely.

If desired, install the optional hood. Note the location of the three clips inside the top air channel above the door. The clips are equally spaced on the top surface of the air channel opening. Use a screwdriver to open the clips slightly if needed. Engage the back edge of the eyebrow into the clips to secure.

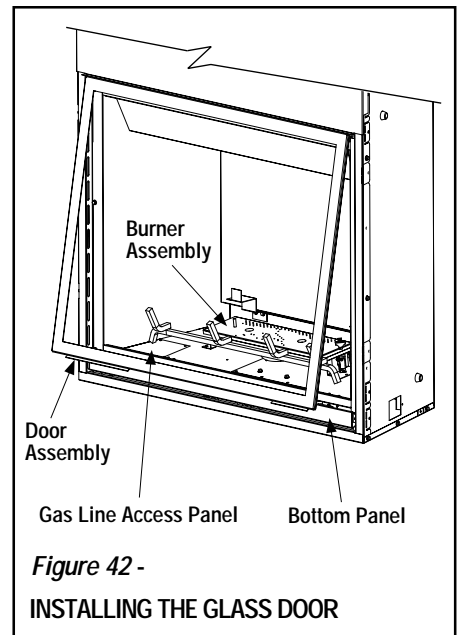

Figure 42 -

INSTALLING THE GLASS DOOR

WARNING: HANDLE THIS GLASS WITH EXTREME CARE! THE GLASS PANEL IS SUSCEPTIBLE TO DAMAGE — DO NOT SCRATCH WHILE HANDLING OR WHILE RE-INSTALLING THE GLASS DOOR FRAME.

WARNING: DO NOT OPERATE APPLIANCE WITH THE GLASS FRONT REMOVED, CRACKED OR BROKEN. REPLACEMENT OF THE GLASS SHOULD BE DONE BY A LICENSED OR QUALIFIED SERVICE TECHNICIAN.

Step 9. BURNER ADJUSTMENTS

Flame Appearance and sooting

Proper flame appearance is a matter of taste. Generally, most people prefer the warm glow of a yellow to orange flame. Appliances operated with air shutter openings that are too large will exhibit flames that are blue and transparent. These weak, blue and transparent flames are termed anemic. If the air shutter opening is too small sooting may develop.

Sooting is indicated by black puffs developing at the tips of very long orange flames. Sooting results in black deposits forming on the logs, appliance inside surfaces and on exterior surfaces adjacent to the vent termination. Sooting is caused by incomplete combustion in the flames and lack of combustion air entering the air shutter opening. To achieve a warm yellow to orange flame with an orange body that does not soot, the shutter opening must be adjusted between these two extremes.

No smoke or soot should be present. These logs are designed to be involved in the fire. Flames will impinge the top tips of the right and left logs.

If the logs are properly positioned and sooting conditions exist, the air shutter opening on the main burner tube should be adjusted. Normally, the more offsets in the vent system, the greater the need for the air shutter to be opened further.

Burner Adjustment

WARNING: AIR SHUTTER ADJUSTMENT SHOULD ONLY BE PERFORMED BY A QUALIFIED PROFESSIONAL SERVICE TECHNICIAN.

IMPORTANT: ENSURE THAT THE FRONT GLASS PANEL IS IN PLACE AND SEALED DURING ADJUSTMENT.

CAUTION: THE AIR SHUTTER DOOR AND NEARBY APPLIANCE SURFACES ARE HOT. EXERCISE CAUTION TO AVOID INJURY WHILE ADJUSTING FLAME APPEARANCE.

To adjust the flame, rotate the lever arm up or down (rod located in the lower control area). Position the air shutter to the factory setting as shown in the table in *Figure 43*. Allow the burner to operate for at least 20 minutes.

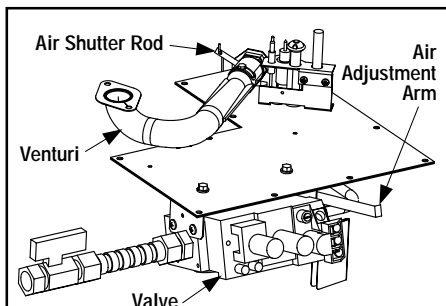

**MAIN BURNER
FACTORY SHUTTER OPENING SETTING**

Models	Natural Gas inches (mm)	Propane Gas inches (mm)
MPLDV30	3/32 (2.38)	3/16 (4.76)
MPLDV35	1/16 (1.6)	1/4 (6.35)
MPLDV40	1/4 (6.35)	3/8 (9.5)
MPLDV45	1/4 (6.35)	1/2 (12.7)

Figure 43

CAUTION: DO NOT BEND THE AIR SHUTTER ROD. MAKE SURE THE AIR SHUTTER MOVES WHEN THE LEVER ARM IS OPERATED.

Note: When first operating the air shutter adjustment lever arm observe the air shutter. If it is not moving, open the glass, ensure the air shutter screw is loose and adjust by hand through a couple of cycles, to break the adhesion of paint, if required. Close door and adjust with the lever as needed.

Observe the flame continuously. If it appears weak or sooty as previously described, adjust the air shutter by rotating the adjustment arm up or down (*refer to Figure 39*) until the flame appearance is as desired.

The adjustment rod and associated adjustable air shutter is patented technology. Flame adjustments can be made quickly and accurately to taste without the need of disassembling the appliance and waiting for 30 minutes after each adjustment.

Propane models may exhibit a flame pattern that may candle or appear stringy. If this is problematic or persists as the appliance is continually operated, adjust the air shutter closed as described in the previous paragraphs. Operate the appliance for a period of time as the effect diminishes, ensuring that the appliance does not develop sooty flames.

When satisfied that the appliance operates properly, proceed to finish the installation. Leave the control knob in the ON position and the remote switch OFF. Close the lower control compartment door.

FINISHING REQUIREMENTS Wall Details

Complete finished interior wall. To install the appliance facing flush with the finished wall, position framework to accommodate the thickness of the finished wall (*Figure 44*)

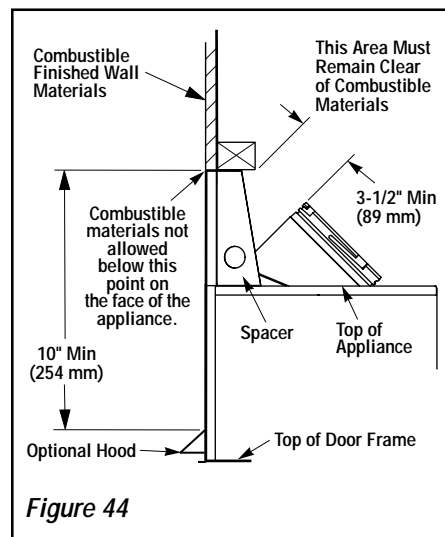

Figure 44

A hearth extension is not required with this appliance. If a hearth extension is used, do not block the lower control compartment door. Any hearth extension used is for appearance only and does not have to conform to standard hearth extension installation requirements.

Note: Combustible wall finish materials and/or surround materials must not be allowed to be placed in direct contact with the area defined by the appliance front face (black sheet metal). Never allow combustible materials to overlap the appliance front face. See **Figure 44** on page 25. Combustible mantel materials may be placed in front of non-combustible facing materials, as shown in **Figure 45**.

Non-combustible materials, such as surrounds and other appliance trim, may be installed on the appliance front face with these exceptions: they must not cover any portion of the glass or hood; they may cover any portion of the top radiant panel or the air gaps surrounding the top radiant panel up to the installed hood.

Vertical installation clearances to combustible mantels vary according to the depth of the mantel. See **Figure 45**. Mantels constructed of non-combustible materials may be installed at any height above the appliance opening; however, do not allow anything to hang below the hood.

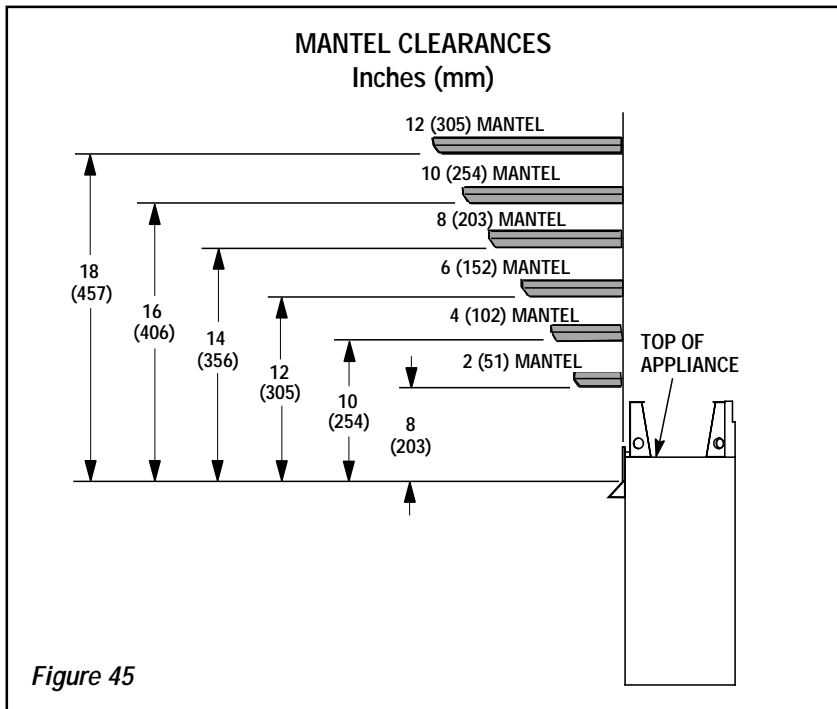

Figure 45

Combustible materials may project beyond the sides of the fireplace opening as long as they are kept within the shaded areas illustrated in **Figure 46**.

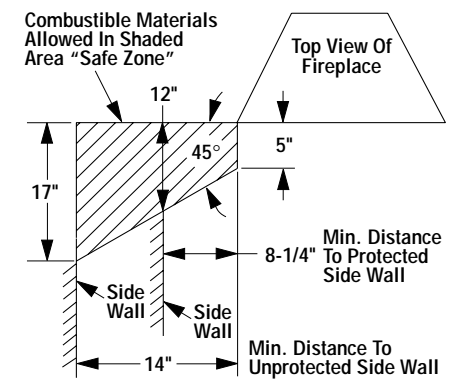

Figure 46

COLD CLIMATE INSULATION

For cold climate installations, seal all cracks around your appliance with noncombustible material and wherever cold air could enter the room. It is especially important to insulate outside chase cavity between studs and under floor on which appliance rests, if floor is above ground level. Gas line holes and other openings should be caulked or stuffed with unfaced fiberglass insulation. In cold climates, if the fireplace is being installed on a cement slab, a sheet of plywood or other raised platform can be placed underneath to prevent conducting cold up into the room. It also helps to sheetrock inside surfaces and tape for maximum air tightness and caulk firestops.

INSTALLATION ACCESSORIES

Listed Secure Vent™ Components			
	Cat.No.	Model No.	Description
	**94L10	SV4.5HTSS	Horizontal Small Square Termination with Firestop/Spacer (96K80) and Adapter (74L61)
	**98L27	SV4.5HTSSL	Horizontal Small Square-Long Termination with Firestop/Spacer (96K80) and Adapter (74L61)

** May be used with 30" and 35" models only.

Listed Secure Flex™ Components			
	Cat. No.	Model No.	Description
	10K81	SFMP	Mil Pac Black Hi-Temperature Sealant
	89L40	SFMP-12	Mil Pac Black Hi-Temperature Sealant - Bulk Pack 12
	91L66	SF-GC4-6	Gear Clamp 4.5in. (114 mm) for Flex (6 pieces)
	91L67	SF-GC7-6	Gear Clamp 7.5 in. (190.5 mm) for Flex (6 pieces)
	H2248	SF4.5HF	Firestop/Spacer - 10 Pack Horizontal (3-1-1 spacing)
	H2249	SF4.5VF	Firestop/Spacer - 10 Pack Vertical (1-1-1 spacing)

INSTALLATION ACCESSORIES CONTINUED

Listed Secure Vent™ Components			
	Cat. No.	Model No.	Description
	H1968	SV4.5HT-2	Horizontal Square Termination with Firestop/Spacer (96K80) and Adapter (74L61)
	H2152	SV4.5CGV-1	Vertical Termination
	H4687 H4716 H4717	SV4.5CTS SV4.5CTS-B SV4.5CTS-TC	Chase Top Term. Square Chase Top Term. Square, Blk Terra Cotta Termination
	77L70	SV4.5L6	6 inch (152 mm) Vent Section
	77L71	SV4.5L12	12 inch (305 mm) Vent Section
	77L72	SV4.5L24	24 inch (610 mm) Vent Section
	77L73	SV4.5L36	36 inch (914 mm) Vent Section
	77L74	SV4.5L48	48 inch (1219 mm) Vent Section
	77L75	SV4.5LA	Telescopic Section
	77L76	SV4.5E45	45 Degree Elbow
	77L77	SV4.5E90	90 Degree Elbow
The following flashings come packaged with a storm collar.			
	77L78	SV4.5F	Flat Roof Flashing
	77L79	SV4.5FA	1/12 to 7/12 Adjust. Flashing
	77L80	SV4.5FB	7/12 to 12/12 Adjust. Flashing
	77L81	SV4.5SC6	Storm Collars (6 collars/box)
	H6183	SV4.5HF5	Firestop/Spacer Horizontal (5-1-1 spacing)
	H6184	SF4.5HF5	Firestop/Spacer Flex Horizontal (5-1-1 spacing)
	H2247	SV4.5VF	Firestop/Spacer - 10 Pack Vertical (1-1-1 spacing)
	96K93	SV4.5SU	Support Strap
	96K94	SV4.5RSA	Attic Insulation Shield
	96K92	SV4.5SP	Support Plate
	87L02	SV4.5 HGS	Termination Guard
	99L03	SV4.5HRK36	Horizontal Riser Kit 36"
	99L02	SV4.5HRK14	Horizontal Riser Kit 14"

Listed Secure Flex™ Components			
	Cat. No.	Model No.	Description
These termination kits include firestop/spacer, gear clamps and flex adapter.			
	H1969	SF4.5HT-2	Horizontal Square Termination without Flex
	77L87	SFKIT12	Flex Square Term. with 12 in. (305 mm of *compressed Flex
	77L88	SFKIT18	Flex Square Term. with 18 in. (457 mm) of *compressed Flex
	77L89	SFKIT24	Flex Square Term. with 24 in. (610 mm) of *compressed Flex
	77L90	SFKIT36	Flex Square Term. with 36 in. (914 mm) of *compressed Flex
	77L91	SFKIT48	Flex Square Term. with 48 in. (1219 mm) of *compressed Flex
	56L74	SFVT30	Vertical Termin. for Flex (flat to 6/12) with Flex Adapter, section of rigid vent, roof support collar assembly, roof flashing and storm collar.
	56L75	SFVT45	Vertical Termin. for Flex (6/12 to 12/12) with Flex Adapter section of rigid vent, roof support collar assembly, roof flashing and storm collar.
	60L10	SF-18	18 ft. (5.49 m) *compressed Flex
	98K03	SF-12	12 ft. (3.66 m) *compressed Flex

	Cat. No.	Model No.	Description
These termination kits include firestop/spacer, gear clamps and flex adapter.			
	**94L09	SF-HTSS	Horizontal Small Square Termination without Flex
	**94L04	SFKIT12SS	Flex Small Square Term. with 12 in. (305 mm) of *compressed Flex
	**94L05	SFKIT18SS	Flex Small Square Term. with 18 in. (457 mm) of *compressed Flex
	**94L06	SFKIT24SS	Flex Small Square Term. with 24 in. (610 mm) of *compressed Flex
	**94L07	SFKIT36SS	Flex Small Square Term. with 36 in. (914 mm) of *compressed Flex
	**94L08	SFKIT48SS	Flex Small Square Term. with 48 in. (1219 mm) of *compressed Flex

	Cat. No.	Model No.	Description
	H1988	CTSA-33	Chase Top Shroud Kit, Arch Top 3 x 3
	H1985	CTSO-33	Chase Top Shroud Kit, Open Top 3 x 3
	H1987	CTSO-44	Chase Top Shroud Kit, Open Top 4 x 4
	H1986	CTSO-46	Chase Top Shroud Kit, Open Top 4 x 6
	H5820	4.5HTSK	Termination Shroud Kit

* All compressed flex vents can be expanded up to two times.

** May be used with 30" and 35" models only.

GAS CONVERSION KITS

WARNING: THIS CONVERSION KIT SHALL BE INSTALLED BY A QUALIFIED SERVICE AGENCY IN ACCORDANCE WITH THE MANUFACTURER'S INSTRUCTIONS AND ALL APPLICABLE CODES AND REQUIREMENTS OF THE AUTHORIZED HAVING JURISDICTION. IF THE INFORMATION IN THESE INSTRUCTIONS IS NOT FOLLOWED EXACTLY, A FIRE, EXPLOSION OR PRODUCTION OF CARBON MONOXIDE MAY RESULT CAUSING PROPERTY DAMAGE, PERSONAL INJURY OR LOSS OF LIFE. THE INSTALLATION IS NOT PROPER AND COMPLETE UNTIL THE OPERATION OF THE CONVERTED APPLIANCE IS CHECKED AS SPECIFIED IN THE OWNER INSTRUCTIONS SUPPLIED WITH THE KIT. THE QUALIFIED SERVICE AGENCY PERFORMING THIS INSTALLATION ASSUMES RESPONSIBILITY FOR THIS CONVERSION.

AVERTISSEMENT: CET ÉQUIPEMENT DE CONVERSION SERA INSTALLÉ PAR UNE AGENCE QUALIFIÉE DE SERVICE CONFORMÉMENT AUX INSTRUCTIONS DU FABRICANT ET TOUTES EXIGENCES ET CODES APPLICABLES DE L'AUTORISÉ AVOIR LA JURISDICTION. SI L'INFORMATION DANS CETTE INSTRUCTION N'EST PAS SUIVIE EXACTEMENT, UN FEU, EXPLOSION OU PRODUCTION DE PROTOXYDE DE CARBONE PEUT RÉSULTER LE DOMMAGES CAUSER DE PROPRIÉTÉ, PERTE OU BLESSURE PERSONNELLE DE VIE. L'AGENCE QUALIFIÉE DE SERVICE EST ESPONSABLE DE L'INSTALLATION PROPRE DE CET ÉQUIPEMENT. L'INSTALLATION N'EST PAS PROPRE ET COMPLÈTE JUSQU'À L'OPÉRATION DE L'APPAREIL CONVERTI EST CHÉQUE SUIVANT LES CRITÈRES ÉTABLIS DANS LES INSTRUCTIONS DE PROPRIÉTAIRE PROVISIONNÉES AVEC L'ÉQUIPEMENT.

In Canada:

THE CONVERSION SHALL BE CARRIED OUT IN ACCORDANCE WITH THE REQUIREMENTS OF THE PROVINCIAL AUTHORITIES HAVING JURISDICTION AND IN ACCORDANCE WITH THE REQUIREMENTS OF THE CAN1-B149.1 AND .2 INSTALLATION CODE.

LA CONVERSION DEVRA ÊTRE EFFECTUÉE CONFORMÉMENT AUX RECOMMANDATIONS DES AUTORITÉS PROVINCIALES AYANT JURISDICTION ET CONFORMÉMENT AUX EXIGENCES DU CODE D'INSTALLATION CAN1-B149.1 ET.2.

Gas conversion kits are available to adapt your appliance from the use of one type of gas to the use of another. These kits contain all the necessary components needed to complete the task including labeling that must be affixed to ensure safe operation.

Kit part numbers are listed here and the following steps detail the conversion procedure.

Step 1. Turn off the gas supply to the appliance.

Step 2. Carefully remove the logs. Exercise care so as not to break the logs.

Step 3. Refer to *Figure 47*.

Remove the burner assembly with attached venturi tube.

Natural To Propane Gas Conversion Kit		
Models No.	Unit Type	Catalog No.
MPLDV30	millivolt	H6163
MPLDV35	millivolt	H6975
MPLDV40	millivolt	85L59
MPLDV45	millivolt	85L69
MPLDV30	electronic	H6166
MPLDV35	electronic	H6973
MPLDV40	electronic	H6168
MPLDV45	electronic	H6169

Propane to Natural Gas Conversion Kit		
Model No.	Unit Type	Catalog No.
MPLDV30	millivolt	H6165
MPLDV35	millivolt	H6968
MPLDV40	millivolt	H6177
MPLDV45	millivolt	85L62
MPLDV30	electronic	H6170
MPLDV35	electronic	H6974
MPLDV40	electronic	H6172
MPLDV45	electronic	H6173

Millivolt Appliances

Step 4. SIT Systems - Refer to *Figure 48 on page 29* and the instructions provided with the kit. Using a Torx T20, remove and discard the three pressure regulator mounting screws. Remove the pressure regulator, spring, poppet, diaphragm and bushing. **Discard all removed components.**

Ensure the rubber gasket installed on the back of the replacement pressure regulator is properly positioned and install the new pressure regulator using the new screws supplied with the kit. Tighten screws to 25 In. lb. torque.

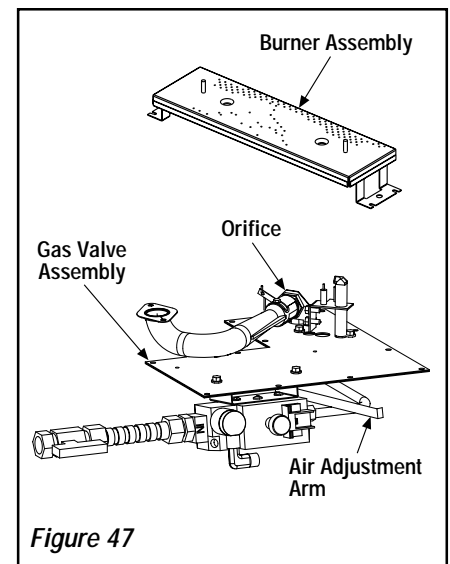
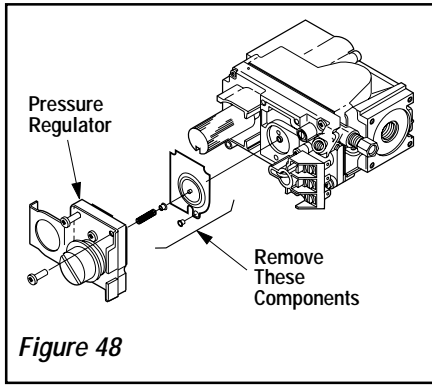
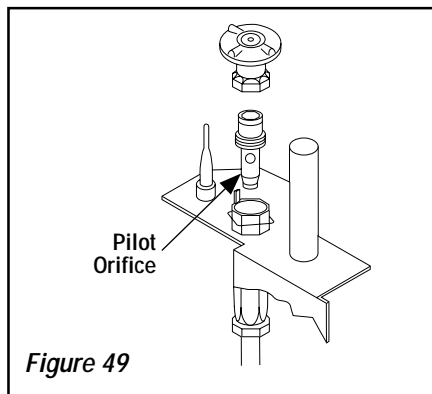

Figure 47



Step 5. Attach manometer to the manifold side pressure test fitting and verify manifold pressure reads 3.5 inches water column (0.87 kPa) for natural gas, and 10.0 inches water column (2.49 kPa) for propane gas.

Step 6. Refer to **Figure 49** and remove the pilot hood assembly to access the hexed pilot orifice. Remove and replace the orifice with the one provided with the kit.



Electronic Appliances

Step 7. Dexen Electronic Valves -
See **Figure 50** and the instructions provided with the kit. Remove and discard the two pressure regulator mounting screws. Remove the pressure regulator and diaphragm. Discard all removed components. Ensure the provided diaphragm is installed properly onto the replacement pressure regulator and install the new pressure regulator using the new screws supplied with the kit. Tighten screws.

See **Figure 51** and replace the pilot orifice as follows: Remove pilot hood assembly to access the phillipped pilot orifice. Remove and replace the orifice with the one provided with the kit. **Exercise extreme care to prevent damage to or breakage of the ignitor assembly.**

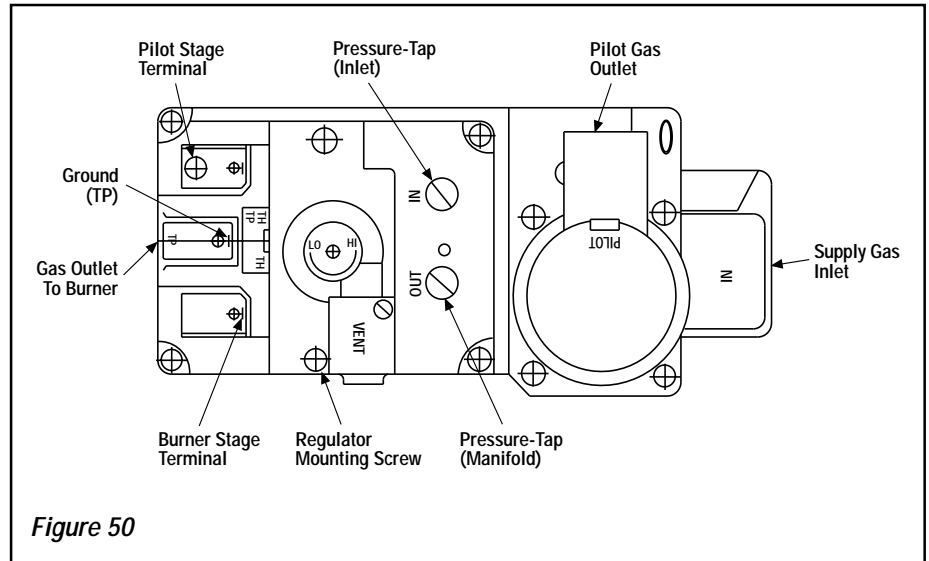
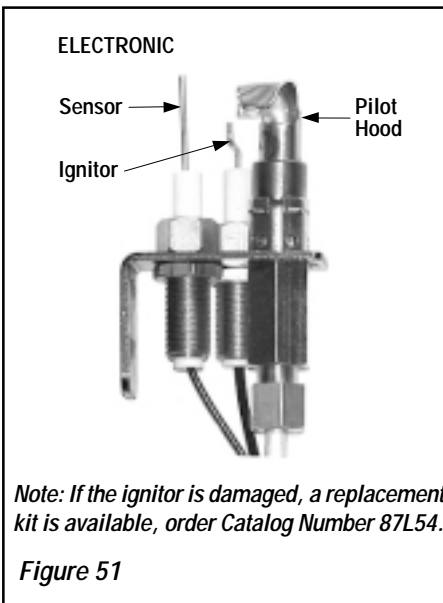

Figure 50



Note: If the ignitor is damaged, a replacement kit is available, order Catalog Number 87L54.

Figure 51

All Models

Step 8. (Refer to Figure 47 on page 28)
A. Remove the orifice from the manifold and replace it with the one provided in the kit. See the following table for orifice sizes for natural and propane models. **Figure 52** illustrates the orifice.

B. Retrieve the burner and slide the venturi tube over the orifice. Set the shutter adjusting opening as shown in **Figure 43**, page 25.

Model No.	Orifice size	
	Natural	Propane
MPLDV-30	0.070"	#61 (0.039")
MPLDV-35	#45 (0.082")	0.048"
MPLDV-40	#41 (0.046")	#54 (0.055")
MPLDV-45	#40 (0.098")	#53 (0.595")

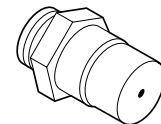

Figure 52

Step 9. Reassemble the remaining components by reversing the procedures outlined in the preceding steps. Use pipe joint compound or Teflon tape on all pipe fittings before installing (ensure propane resistant compounds are used in propane applications, do not use pipe joint compounds on flare fittings).

Step 10. Attach the conversion label provided in the conversion kit to the rating plate on the appliance.

Step 11. Turn on gas supply and test for gas leaks.

Lennox Hearth Products reserves the right to make changes at any time, without notice, in design, materials, specifications, prices and also to discontinue colors, styles and products. Consult your local distributor for fireplace code information.



HEARTH PRODUCTS

1110 West Taft Avenue • Orange, CA 92865

Printed in U.S.A. © 2007 by Lennox Hearth Products
P/N 850,043M REV. F 09/2008