

This Owner's Manual is provided and hosted by [Appliance Factory Parts](#).



LENNOX HEARTH LSM40N Owner's Manual

[Shop genuine replacement parts for LENNOX HEARTH
LSM40N](#)



[Find Your LENNOX HEARTH Fireplace Parts - Select From 237 Models](#)

----- Manual continues below -----



LENNOX HEARTH PRODUCTS

HOMEOWNER'S CARE AND OPERATION INSTRUCTIONS

DIRECT VENT MONTEBELLO® SERIES

VENTED GAS FIREPLACE - DIRECT VENT MODELS
P/N 875,027M REV. A 06/2005

MODELS

Millivolt Models

LSM40N
LSM40L
LSM40NE

Electronic Models

LSM45N
LSM45L
LSM45NE



LSM40 Shown

WARNING: IF THE INFORMATION IN THIS MANUAL IS NOT FOLLOWED EXACTLY, A FIRE OR EXPLOSION MAY RESULT CAUSING PROPERTY DAMAGE, PERSONAL INJURY OR LOSS OF LIFE.

FOR YOUR SAFETY: Do not store or use gasoline or other flammable vapors or liquids in the vicinity of this or any other appliance.

FOR YOUR SAFETY: What to do if you smell gas:

- DO NOT light any appliance.
- DO NOT touch any electrical switches.
- DO NOT use any phone in your building.
- Immediately call your gas supplier from a neighbor's phone. Follow your gas suppliers instructions.
- If your gas supplier cannot be reached, call the fire department.

Installation and service must be performed by a qualified installer, service agency or the gas supplier.

This appliance may be installed in an aftermarket permanently located, manufactured home (USA only) or mobile home, where not prohibited by local codes. This appliance is only for use with the type of gas indicated on the rating plate. This appliance is not convertible for use with other gases, unless a certified kit is used.



OMNI-Test Laboratories, Inc.

OTL Report No. 116-F-22-5

**RETAIN THESE INSTRUCTIONS
FOR FUTURE REFERENCE**

A French manual is available upon request. Order Form Number 875,027CF.

Ce manuel d'installation est disponible en français, simplement en faire la demande. Numéro de la pièce 875,027CF.

CONGRATULATIONS!

In selecting this LENNOX Direct-Vent Gas Appliance you have chosen the finest and most dependable fireplace to be found anywhere. A beautiful, prestigious, alternative to a wood burning fireplace. Welcome to a Family of tens of thousands of satisfied LENNOX Fireplace Owners.

Please read and carefully follow all of the instructions found in this manual. Please pay special attention to the safety instructions provided in this manual. The Homeowner's Care and Operation Instructions included here will assure that you have many years of dependable and enjoyable service from your LENNOX product.

TABLE OF CONTENTS

Introduction	page 2
General Information	page 2
Operation/Care of Your Appliance	page 3
Variable Flame Adjustment	page 4
Glass Cleaning	page 4
Maintenance	page 4
Maintenance Schedule	page 5
Front Glass Enclosure Panel, Removal and Installation	page 6
Burner Adjustments	page 6
Flame Appearance and Sooting	page 6
Adjustment	page 6
Log Placement	page 7
Glowing Embers (Rockwool) Placement	page 8
Millivolt Appliance Checkout	page 8
Electronic Appliance Checkout	page 8
Accessory Components	page 8
Wiring Diagrams	page 10
Warranty	page 10
Replacement Parts	page 10
Product Reference Information	page 10
Lighting Instructions – Millivolt	page 11
Lighting Instructions – Electronic	page 12
Troubleshooting Guide – Millivolt	page 13
Troubleshooting Guide – Electronic	page 14
Replacement Parts List	page 15

INTRODUCTION

The Fireplace models covered in this manual are Direct-Vent sealed combustion gas fireplaces designed for residential application. Direct-Vent appliances operate with the combustion chamber completely isolated from the inside atmosphere. All air for combustion is brought in from the outside and exhaust gases are vented through the same direct vent, vent system.

The millivolt appliances are designed to operate on either natural or propane gas. A millivolt gas control valve with piezo ignition system provides safe, efficient operation.

The electronic appliances are designed to operate on natural gas only. An electronic intermittent pilot system provides safe, efficient operation. External electrical power is required to operate these units.

These appliances comply with National Safety Standards and are tested and listed by Omni-Test Laboratories (Report No. 116-F-22-5) to ANSI Z21.50-2003 (in Canada, CSA-2.22-2003), and CAN/CGA-2.17-M91 in both USA and Canada, as vented gas fireplaces.

The Installation must conform to local codes or, in the absence of local codes, with the *National Fuel Gas Code, ANSI Z223.1/NFPA 54*, or the *Natural Gas and Propane Installation Code, CSA B149.1*. The appliance, when installed, must be electrically grounded in accordance with local codes or, in the absence of local codes, with the *National Electrical Code, ANSI/NFPA 70*, or the *Canadian Electrical Code, CSA C22.1*.

DO NOT ATTEMPT TO ALTER OR MODIFY THE CONSTRUCTION OF THE APPLIANCE OR ITS COMPONENTS. ANY MODIFICATION OR ALTERATION MAY VOID THE WARRANTY, CERTIFICATION AND LISTINGS OF THIS UNIT.

WARNING: IMPROPER INSTALLATION, ADJUSTMENT, ALTERATION, SERVICE OR MAINTENANCE CAN CAUSE INJURY OR PROPERTY DAMAGE. REFER TO THIS MANUAL. FOR ASSISTANCE OR ADDITIONAL INFORMATION CONSULT A QUALIFIED INSTALLER, SERVICE AGENCY OR THE GAS SUPPLIER.

GENERAL INFORMATION

Note: Installation and repair should be performed by a qualified service person. The appliance should be inspected annually by a qualified professional service technician. More frequent inspections and cleanings may be required due to excessive lint from carpeting, bedding material, etc. It is imperative that the control compartment, burners and circulating air passage ways of the appliance be kept clean.

S'assurer que le brûleur et le compartiment des commandes sont propres. Voir les instructions d'installation et d'utilisation qui accompagnent l'appareil.

Provide adequate clearances around air openings and adequate accessibility clearance for service and proper operation. Never obstruct the front openings of the appliance.

Due to high temperatures the appliance should be located out of traffic and away from furniture and draperies. Locate furniture and window coverings accordingly.

WARNING: THESE APPLIANCES ARE VENTED GAS FIREPLACES. DO NOT BURN WOOD OR OTHER MATERIAL IN THESE APPLIANCES.

These appliances are designed to operate on natural or propane gas only.

Millivolt Models -

Input of millivolt models is shown in the following table:

Millivolt Models with Manually-Modulated Gas Valve			
Natural Gas		Propane Gas	
Model No.	Input rate (BTU/H)	Model No.	Input rate (BTU/H)
LSM40	40,000 to 50,000	LSM40	40,000 to 50,000
LSM45	47,000 to 60,000	LSM45	42,000 to 55,000

Electronic Models -

Electronic models have a manually-modulated gas valve. Input of electronic models is shown in the following table:

Electronic Models with Manually-Modulated Gas Valve			
Natural Gas		Propane Gas	
Model No.	Input rate (BTU/H)	Model No.	Input rate (BTU/H)
LSM40	40,000 to 50,000	LSM40	40,000 to 50,000
LSM45	47,000 to 60,000	LSM45	42,000 to 55,000

Table 1 shows the units' gas orifice size for the elevations indicated.

Model No.	Orifice size		Elevation Feet (meters)
	Nat.	Prop.	
LSM40	0.1495" (#25)	0.086" (#44)	0-4500 (0-1372)
LSM45	0.161" (#20)	0.089" (#43)	

Table 1

Maximum manifold pressure is 3.5 in. w.c. (0.87 kPa) for natural gas and 10 in. w.c. (2.49 kPa) for LP/Propane gas.

Do not use these appliances if any part has been under water. Immediately call a qualified, professional service technician to inspect the appliance and to replace any parts of the control system and any gas control which have been under water.

Ne pas se servir de cet appareil s'il a été plongé dans l'eau, complètement ou en partie. Appeler un technicien qualifié pour inspecter l'appareil et remplacer toute partie du système de contrôle et toute commande qui ont été plongés dans l'eau.

Test gage connections are provided on the front of the millivolt gas control valve (identified OUT for the manifold side and IN for inlet pressure). A 1/8" NPT test gage connection is provided on the electronic gas control valve adjacent to the outlet to the main burner.

Minimum inlet gas pressure to these appliances is 5.5 inches water column (1.24 kPa) for natural gas and 11 inches water column (2.74 kPa) for propane for the purpose of input adjustment.

Maximum inlet gas supply pressure to these appliances is 10.5 inches water column (2.61 kPa) for natural gas and 13.0 inches water column (3.23 kPa) for propane.

The appliance must be isolated from the gas supply piping system (by closing its individual manual shut-off valve) during any pressure testing of the gas supply piping system at test pressures equal to or less than 1/2 psig (3.5 kPa).

The appliance and its individual shut-off valve must be disconnected from the gas supply piping system during any pressure testing of that system at pressures in excess of 1/2 psig (3.5 kPa).

These appliances must not be connected to a chimney or flue serving a separate solid fuel burning appliance.

Any safety guard or screen removed for servicing the appliance must be replaced prior to operating the appliance.

WARNING: FAILURE TO COMPLY WITH THE INSTALLATION AND OPERATING INSTRUCTIONS PROVIDED IN THIS DOCUMENT WILL RESULT IN AN IMPROPERLY INSTALLED AND OPERATING APPLIANCE, VOIDING ITS WARRANTY. ANY CHANGE TO THIS APPLIANCE AND/OR ITS OPERATING CONTROLS IS DANGEROUS. IMPROPER INSTALLATION OR USE OF THIS APPLIANCE CAN CAUSE SERIOUS INJURY OR DEATH FROM FIRE, BURNS, EXPLOSION OR CARBON MONOXIDE POISONING.

Carbon Monoxide Poisoning: Early signs of carbon monoxide poisoning are similar to the flu with headaches, dizziness and/or nausea. If you have these signs, obtain fresh air immediately. Turn off the gas supply to the appliance and have it serviced by a qualified professional, as it may not be operating correctly.

WARNING: CHILDREN AND ADULTS SHOULD BE ALERTED TO THE HAZARDS OF HIGH SURFACE TEMPERATURES. USE CAUTION AROUND THE APPLIANCE TO AVOID BURNS OR CLOTHING IGNITION. YOUNG CHILDREN SHOULD BE CAREFULLY SUPERVISED WHEN THEY ARE IN THE SAME ROOM AS THE APPLIANCE.

WARNING: DO NOT PLACE CLOTHING OR OTHER FLAMMABLE MATERIALS ON OR NEAR THIS APPLIANCE.

AVERTISSEMENT: SURVEILLER LES ENFANTS. GARDER LES VÊTEMENTS, LES MEUBLES, L'ESSENCE OU AUTRES LIQUIDES À VAPEUR INFLAMMABLES LOIN DE L'APPAREIL.

OPERATION AND CARE OF YOUR APPLIANCE

Appliance operation may be controlled by the following means: the factory provided ON-OFF control switch, a remotely located optional wall switch or optional remote control. The mounted ON-OFF control switch is located on the right hand side of the appliance. See **Figure 1**.

Gas Controls/Control Compartment Access

The gas controls can be found on the right hand side of the appliance.

On millivolt systems, the piezo ignitor, Hi/Lo flame adjustment knob, and pilot and main gas ON/OFF control knob are located on the right side. On both millivolt and electronic systems the gas valve is located on the right side of the appliance. See **Figure 1**.

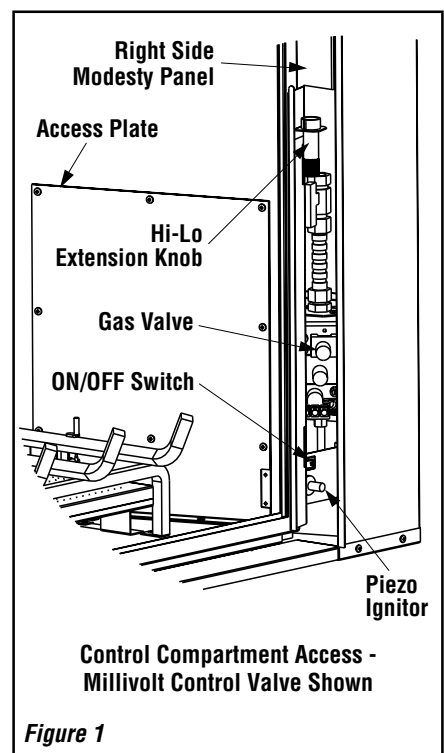

Figure 1

Operation of millivolt and electronic gas control systems are different. Before lighting and operating your appliance determine if you have a millivolt or electronic appliance.

Refer to **Figure 1** for access to the gas control valve. Millivolt appliances will be fitted with the gas control valve shown in **Figure 2**.

Appliances with electronic systems will be fitted with the electronic valve shown in **Figure 3**. Familiarize yourself with the gas control valve that your appliance uses.

Millivolt Appliances -

To light millivolt appliances refer to the detailed lighting instructions found on **page 11**. **Millivolt appliance lighting instructions may also be found on the pull out lighting instruction labels attached to the gas control valve.**

Millivolt appliances are fitted with an ON/OFF Rocker Switch for appliance ON/OFF control. See **Figure 1** for its location. Once the pilot is lit, the ON/OFF rocker switch will control the appliance ON/OFF operation. To operate: Toggle the switch between its ON and OFF positions.

If your millivolt appliance is equipped with an optional remote wall switch or remote control kit and the pilot is lit, the appliance main burner may be turned on and off with the wall switch or remote control.

Electronic Appliances -

To light electronic appliances refer to the detailed lighting instructions found on **page 12** of these instructions respectively. **Electronic appliance lighting instructions may also be found on the pull out lighting instruction labels attached to the gas control valve.**

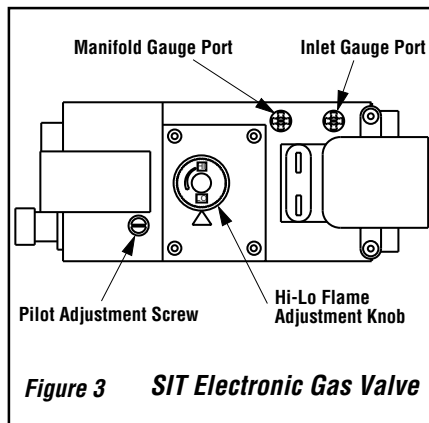

Figure 3 SIT Electronic Gas Valve

Electronic appliances are fitted with an ON/OFF Rocker Switch for appliance ON/OFF control. See **Figure 1** for its location.

Once the pilot is lit, the ON/OFF rocker switch will control the appliance ON/OFF operation. To operate: Toggle the switch between its ON and OFF positions.

If your electronic appliance is equipped with an optional remote wall switch or remote control kit the appliance main burner may be turned on and off with the wall switch or remote control.

Variable Flame Height Adjustment

All appliances are equipped with a variable gas control valve. Flame height for these models may be adjusted through a range between fixed low and high settings, alternately, while the appliance is in operation.

Use the extension knob (refer to Figure 1), to adjust the flame height as desired by sliding the knob over the variable flame adjustment knob located on the front of the valve (refer to Figure 2). Replace the extension knob back to the hanger after the adjustment.

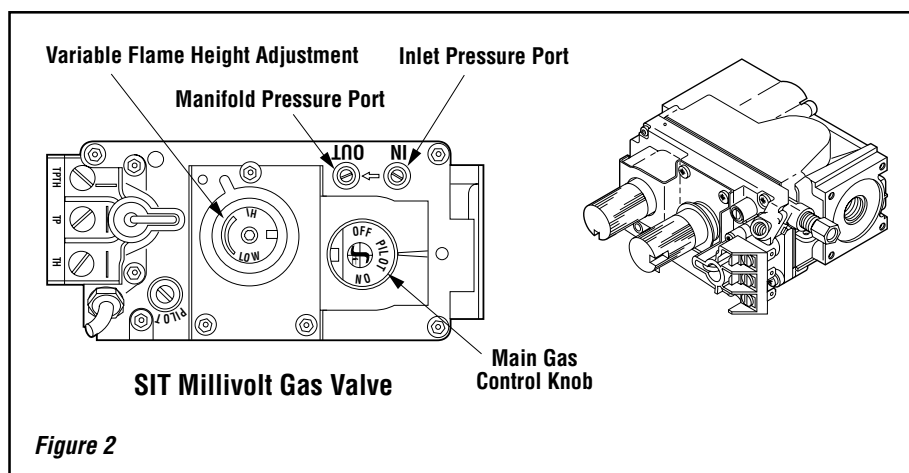

Figure 2

Glass Cleaning

It will be necessary to clean the glass periodically. During start-up it is normal for condensation to form on the inside of the glass. This can cause lint, dust and other airborne particles to cling to the glass surface. Also initial paint curing may deposit a slight film on the glass. It is therefore recommended that the glass be cleaned two or three times with a non-ammonia household cleaner and warm water (a gas fireplace glass cleaner is recommended).

After that the glass should be cleaned two or three times during each heating season, depending on the circumstances present.

Note: Clean glass after first two weeks of operation.

WARNING: DO NOT USE ABRASIVE CLEANERS. NEVER CLEAN THE GLASS WHEN IT IS HOT.

CAUTION: DO NOT ATTEMPT TO TOUCH THE FRONT ENCLOSURE GLASS WITH YOUR HANDS WHILE THE FIREPLACE IS IN USE.

Maintenance

The appliance and venting system should be thoroughly inspected before initial use and at least annually by a qualified service technician. However, more frequent periodic inspections and cleanings should be performed by the homeowner. **Homeowner must contact a qualified service technician at once if any abnormal condition is observed.**

Keep side control compartment clean by vacuuming or brushing at least twice a year. More frequent cleaning may be required due to excessive lint from carpeting, bedding materials, etc. It is important that control compartments, burners and circulating air passage-ways of the appliance be kept clean.

Always turn off gas to the pilot (millivolt appliances) before cleaning. Before re-lighting, refer to the lighting instructions in this manual. Instructions are also found on pull-out lighting instruction labels attached to the gas valve.

Always keep the appliance area clear and free from combustible materials, gasoline and other flammable liquids.

Remember, Millivolt appliances have a continuous burning pilot flame. Exercise caution when using products with combustible vapors.

NOTE: DIAGRAMS & ILLUSTRATIONS NOT TO SCALE.

Maintenance Schedule

Annually (Before the onset of the Burning Season)

Maintenance Task	Accomplishing Person	Procedure
Inspecting/Cleaning Burner, Logs and Controls	Qualified Service Technician	Inspect valve and ensure it is properly operating. Check piping for leaks. Vacuum the control compartment, fireplace logs and burner area.
Check Flame Patterns and Flame Height	Qualified Service Technician	Refer to Figures 6 (LSM40) or 7 (LSM45) on page 7 and verify the flame pattern and height displayed by the appliance conforms to the picture. Flames must not impinge on the logs.
Inspecting/Cleaning Pilot and Burner	Qualified Service Technician	Refer to Figure 8 (Millivolt) or Figure 9 (Electronic) on page 8 . Remove any surface build-up on pilot and burner assembly. Wipe the pilot nozzles, ignitor/flame rod and hood. Ensure the pilot flame engulfs the flame sensor as shown.
Checking Vent System	Qualified Service Technician	Inspect the vent system at the top and at the base (within the firebox) for signs of blockage or obstruction. Look for any signs of dislocation of the vent components.
Appliance Checkout	Qualified Service Technician	Perform the appropriate appliance checkout procedure detailed in this manual.
Replacing Rockwool Ember Materials	Homeowner/Qualified Services Technician	Remove old ember materials and vacuum the rockwool placement area. Place new rockwool as described in this document.

Periodically (After the Burning Season)

Maintenance Task	Accomplishing Person	Procedure
Cleaning Firebox Interior	Homeowner	Carefully remove logs and rockwool. Vacuum out interior of the firebox. Clean firebox bottom and log grate. Replace logs and Rockwool as detailed in this manual.
Check Flame Patterns and Flame Height	Homeowner	Refer to Figures 6 (LSM40) or 7 (LSM45) on page 7 and verify the flame pattern and height displayed by the appliance conforms to the picture. Flames must not impinge on the logs.
Checking Vent System	Homeowner	Inspect the vent system at the top and at the base (within the firebox) for signs of blockage or obstruction. Look for any signs of dislocation of the vent components.
Cleaning Front Glass Enclosure Panel	Homeowner	Clean as necessary following the directions provided in this manual. DO NOT TOUCH OR ATTEMPT TO CLEAN GLASS WHILE HOT.

Refer to the maintenance schedule for maintenance tasks, procedures, periodicity and by whom they should be performed. Always verify proper operation of the appliance after servicing.

IMPORTANT: TURN OFF GAS AND ANY ELECTRICAL POWER BEFORE SERVICING THE APPLIANCE.

Front Glass Enclosure Panel, Removal and Installation

WARNING: DO NOT OPERATE APPLIANCE WITH THE GLASS FRONT REMOVED, CRACKED OR BROKEN. REPLACEMENT OF THE GLASS SHOULD BE DONE BY A LICENSED OR QUALIFIED SERVICE TECHNICIAN.

These are direct-vent appliances. They are designed to operate only when the front glass enclosure panel is installed. Generally the front glass enclosure panel should not be removed except to gain access to the components within the firebox.

WARNING: HANDLE THIS GLASS WITH EXTREME CARE! GLASS IS SUSCEPTIBLE TO DAMAGE – DO NOT SCRATCH OR HANDLE ROUGHLY WHILE REINSTALLING THE GLASS DOOR FRAME.

WARNING: NO NOT ATTEMPT TO SUBSTITUTE THE MATERIALS USED ON THIS DOOR, OR REPLACE CRACKED OR BROKEN GLASS WITH ANY MATERIALS OTHER THAN THOSE PROVIDED BY THE APPLIANCE MANUFACTURER.

THE GLASS DOOR OF THIS APPLIANCE MUST ONLY BE REPLACED AS A COMPLETE UNIT AS PROVIDED BY THE MANUFACTURER. DO NOT ATTEMPT TO REPLACE BROKEN, CRACKED OR CHIPPED GLASS SEPARATELY.

Refer to Figure 4 and remove the front glass door assembly as follows:

To remove the firescreens, lift up the left side of the screen rod and slide it to the left until the right side of the rod is disengaged from the hole. Slowly remove the rod and the firescreens from the fireplace. Using a Phillips screwdriver, unfasten two (2) screws located at the top of the glass frame.

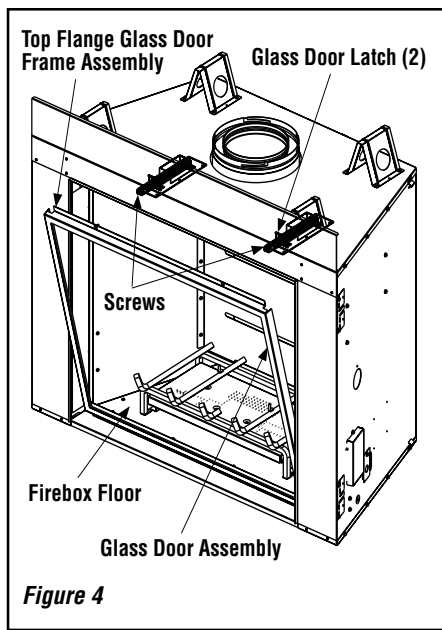

Figure 4

Tilt the glass frame at the top away from the unit. Lift it carefully off the bottom door track and set the door aside, protecting it from inadvertent damage.

To install the front glass door assembly, proceed as follows:

1. Retrieve the glass door assembly. Visually inspect the gasket on the backside of the panel. The gasket surface must be clean, free of irregularities and seated firmly.
2. Position the door frame in front of the firebox opening and engage the bottom flange over the rail at the bottom of the firebox opening.
3. Swing the door up and back. Ensure the gasket seats evenly as the door draws shut. Engage the nut insert and fasten with two screws to secure the door.
4. With the firescreens hanging on the screen rod, slide the right side of the rod through the hole. Then engage the left side of the rod through the slot while making sure that the rod is supported by the bracket in the center of the fireplace.

Burner Adjustments

The following paragraphs address burner adjustment concerns and procedures.

When lit for the first time, this appliance will emit a slight odor for an hour or two. This is due to the "burn-in" of internal paints and lubricants used in the manufacturing process.

Flame Appearance and Sooting

Appliances operated with air shutter openings that are too large will exhibit flames that are blue and transparent. These weak, blue and transparent flames are termed anemic. If the air shutter opening is too small sooting may develop.

Sooting is indicated by black puffs developing at the tips of very long orange flames. Sooting results in black deposits forming on the logs, appliance inside surfaces and on exterior surfaces adjacent to the vent termination.

Sooting is caused by incomplete combustion in the flames and a lack of combustion air entering the air shutter opening. To achieve a warm yellow to orange flame with an orange body that does not soot, the shutter opening must be adjusted between these two extremes. No smoke or soot should be present. Reposition the logs if the flames impinge on any of them.

If the logs are properly positioned and sooting conditions exist, the air shutter opening on the main burner tube should be adjusted. Normally, the more offsets in the vent system, the greater the need for the air shutter to be opened further.

WARNING: AIR SHUTTER ADJUSTMENT SHOULD ONLY BE PERFORMED BY A QUALIFIED PROFESSIONAL SERVICE TECHNICIAN.

ENSURE THAT THE FRONT GLASS DOOR ASSEMBLY IS IN PLACE AND SEALED AFTER ADJUSTMENT.

Adjustment

To adjust the flame, move the adjustment air shutter (located on the lower venturi) back or forward to increase or reduce the air shutter opening, respectively. **Position the air shutter to the factory setting as shown in Figure 5 on page 7.** Allow the burner to operate for at least 15 minutes. Observe the flame continuously. If it appears weak or sooty as previously described, adjust the air shutter until the flame appearance is as desired.

Propane models may exhibit a flame pattern that may candle or appear stringy. If this is problematic or persists as the appliance is continually operated, adjust the air shutter closed as described in the previous paragraphs. Operate the appliance for a period of time as the effect diminishes, ensuring that the appliance does not develop sooty flames.

When satisfied that the appliance operates properly, proceed to finish the installation. Leave the control knob in "ON" position and turn the remote switch "OFF."

NOTE: DIAGRAMS & ILLUSTRATIONS NOT TO SCALE.

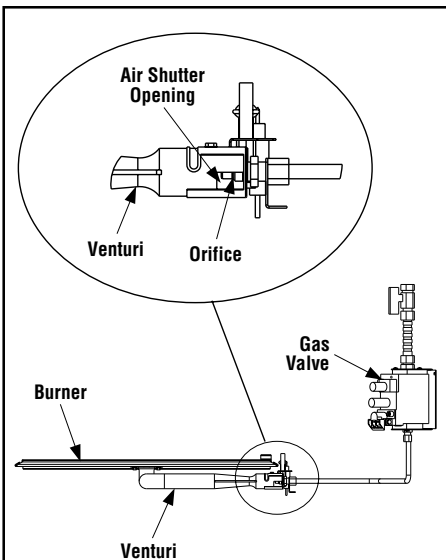

**MAIN BURNER
FACTORY SHUTTER OPENING SETTING**

Models	Natural Gas inches (mm)	Propane Gas inches (mm)
LSM40	1/16 (1.59)	9/32 (7.14)
LSM45		9/32 (7.14)

Figure 5

Log Placement

WARNING: LOGS GET VERY HOT AND WILL REMAIN HOT UP TO ONE HOUR AFTER GAS SUPPLY IS TURNED OFF. HANDLE ONLY WHEN LOGS ARE COOL. TURN OFF ALL ELECTRICITY TO THE APPLIANCE BEFORE YOU INSTALL GRATE AND LOGS, IF APPLICABLE.

WARNING: THIS APPLIANCE IS NOT MEANT TO BURN WOOD. ANY ATTEMPT TO DO SO COULD CAUSE IRREPARABLE DAMAGE TO YOUR APPLIANCE AND PROVE HAZARDOUS TO YOUR SAFETY.

WARNING: THE SIZE AND POSITION OF THE LOG SET WAS ENGINEERED TO GIVE YOUR APPLIANCE A SAFE, RELIABLE AND ATTRACTIVE FLAME PATTERN. ANY ATTEMPT TO USE A DIFFERENT LOG SET IN THE FIREPLACE WILL VOID THE WARRANTY AND WILL RESULT IN INCOMPLETE COMBUSTION, SOOTING, AND POOR FLAME QUALITY.

Carefully position the ceramic fiber logs and twigs over the burner as shown in **Figures 6 (LSM40) or 7 (LSM45) on this page**. Refer to the detailed log placement instructions provided in the **CERAMIC PANEL AND LOG PLACEMENT GUIDE** accompanying this document.

Proper twig placement is critical to prevent sooting. Twigs should be placed in the gaps between the flame peaks and should be positioned so that at no time they impinge the flames.



Figure 6

LSM40



Figure 7

LSM45

NOTE: DIAGRAMS & ILLUSTRATIONS NOT TO SCALE.

Glowing Embers (Rockwool) Placement

Refer to the detailed glowing embers placement instructions provided in the **CERAMIC PANEL AND LOG PLACEMENT GUIDE** accompanying this document.

Ceramic Panel Placement

Refer to the detailed ceramic panel placement instructions provided in the **CERAMIC PANEL AND LOG PLACEMENT GUIDE** accompanying this document.

Millivolt Appliance Checkout

The pilot flame should be steady, not lifting or floating. Flame should be blue in color with traces of orange at the outer edge.

The top $\frac{3}{8}$ " (10 mm) at the pilot generator (thermopile) and the top $\frac{1}{8}$ " min (tip) of the quick drop out thermocouple should be engulfed in the pilot flame. The flame should project 1" (25 mm) beyond the hood at all three ports. See **Figure 8**. To light the burner, refer to the lighting instructions on **page 11**.

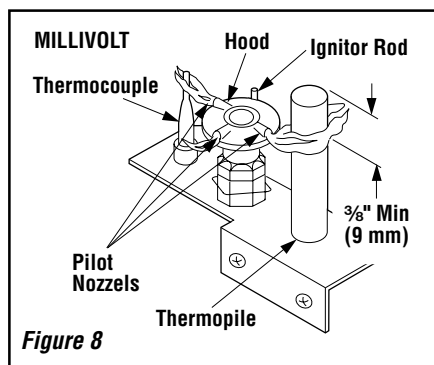

Electronic Appliance Checkout

To light the burner, refer to the lighting instructions on **page 12**. Ensure the ignitor lights the pilot. The pilot flame should engulf the flame sensor as shown in **Figure 9**.

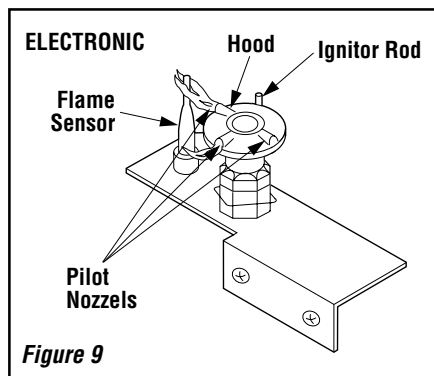

With proper care and maintenance, your appliance will provide many years of enjoyment. If you should experience any problem, first refer to the troubleshooting guide in this manual. If problem persists, contact your Lennox distributor.

ACCESSORY COMPONENTS



Remote Control System (Standard) H0249 RCL

Standard Remote Control System

The Model RCL (Standard) Remote Control System, features a simple On/Off control function for the fireplace. This model includes a hand-held transmitter, a remote receiver with wall-mount coverplate and all hardware required to install the unit. The remote receiver can be wall or hearth mounted.



Flame Modulating Remote Control – Natural Gas H0301 RCL-MN
Flame Modulating Remote Control – LP/Propane Gas H0302 RCL-ML

Flame Modulating Remote Control

Flame Modulating Remote Controls were developed to provide a safe, reliable and user-friendly remote control system for appliances equipped with a Millivolt Gas Valve. A detailed set of instructions are included with each remote.



Remote Control System (Deluxe) H0251 RCL-T

Deluxe Remote Control System

The Model RCL-T (Deluxe) Remote Control System has all of the features of the standard system along with an added easy to read LCD screen which presents access to many enhancements, including; battery power level indicator, timer, mode of operation, thermostatic display including room temperature in either metric or English units, flame indicator and clock. Fully programmable, the Model RCL-T allows for command over nearly all operational and temperature variables, using the hand held remote control transmitter.



CLASSIC

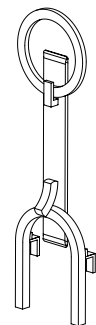

MISSION

Andiron Door Kits

The Andiron kits attach to the grate assembly without the use of hardware.

Andiron Door Kits		
Model No.	Catalog No. Model No.	
	Mission	Classic
LSM40 And LSM45	H2227 AKM-LSM	H2228 AKC-LSM

NOTE: DIAGRAMS & ILLUSTRATIONS NOT TO SCALE.

ACCESSORY COMPONENTS CONTINUED

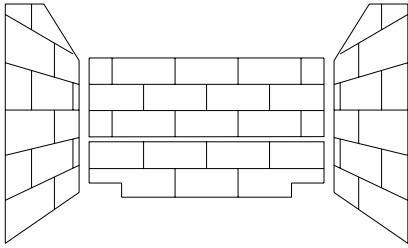

Brick Liner Kits		
Model No.	Catalog No. Model No.	Description
LSM40	H2219 BLKR-LSM40	Rustic
LSM40	H2220 BLKH-LSM40	Herringbone
LSM40	H2221 BLKC-LSM40	Old Cottage
LSM40	H2222 BLKB-LSM40	Black
LSM45	H2223 BLKR-LSM45	Rustic
LSM45	H2224 BLKH-LSM45	Herringbone
LSM45	H2225 BLKC-LSM45	Old Cottage
LSM45	H2226 BLKB-LSM45	Black

The brick panel liner kits include ceramic panels of the side and rear walls. The panels have brick-like features in relief.

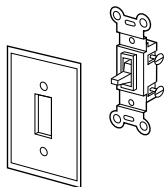

ON/OFF Wall Switch Kit 85L87 FWSK

ON/OFF Wall Switch Kit

The ON/OFF wall switch kit may be used to control the operation of the fireplace burner as an alternative to the modesty panel mounted ON-OFF switch. Install the ON/OFF wall switch in a convenient location near the fireplace.



Touch-Up Paint (Charcoal) Kit 90L74 TPK-C

Touch-Up Paint Kit

Repair of minor scratches and discoloration of the appliance charcoal painted surfaces may be accomplished with the touch-up paint kit.



Bag of Glowing Embers 88L53 FGE

Bag of Glowing Embers

Replacement ember materials are available for use with these appliances. Order a bag of Glowing Embers, Model FGE to replace ember materials as part of the periodic maintenance of the appliance.

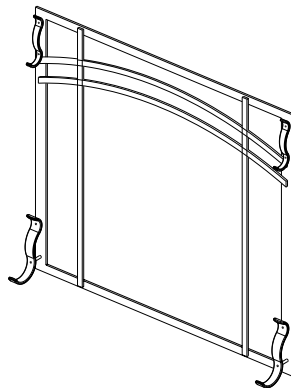

Dual Arch Screen Kits	
Model No.	Catalog No. Model No.
LSM40	H2229 DASK-LSM40
LSM45	H2232 DASK-LSM45

These screen kits can be installed on the glass enclosure panel to provided protection from the hot glass surface.

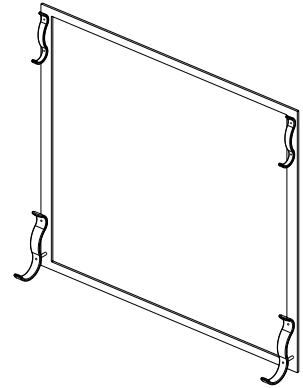

Screen Kits	
Model No.	Catalog No. Model No.
LSM40	H2230 SK-LSM40
LSM45	H2233 SK-LSM45

These screen kits can be installed on the glass enclosure panel to provided protection from the hot glass surface.

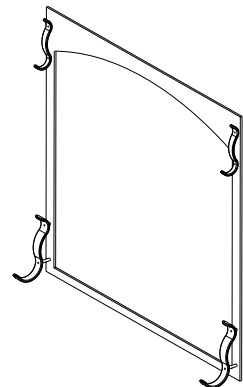

Arch Screen Kits	
Model No.	Catalog No. Model No.
LSM40	H2231 ASK-LSM40
LSM45	H2234 ASK-LSM45

These screen kits can be installed on the glass enclosure panel to provided protection from the hot glass surface.

NOTE: DIAGRAMS & ILLUSTRATIONS NOT TO SCALE.

WIRING DIAGRAMS

Wiring diagrams are provided here for reference purposes only. This information is also provided on schematics attached directly to the appliance on a pullout panel located within the control compartment.

CAUTION: LABEL ALL WIRES PRIOR TO DISCONNECTION WHEN SERVICING CONTROLS. WIRING ERRORS CAN CAUSE IMPROPER AND DANGEROUS APPLIANCE OPERATION.

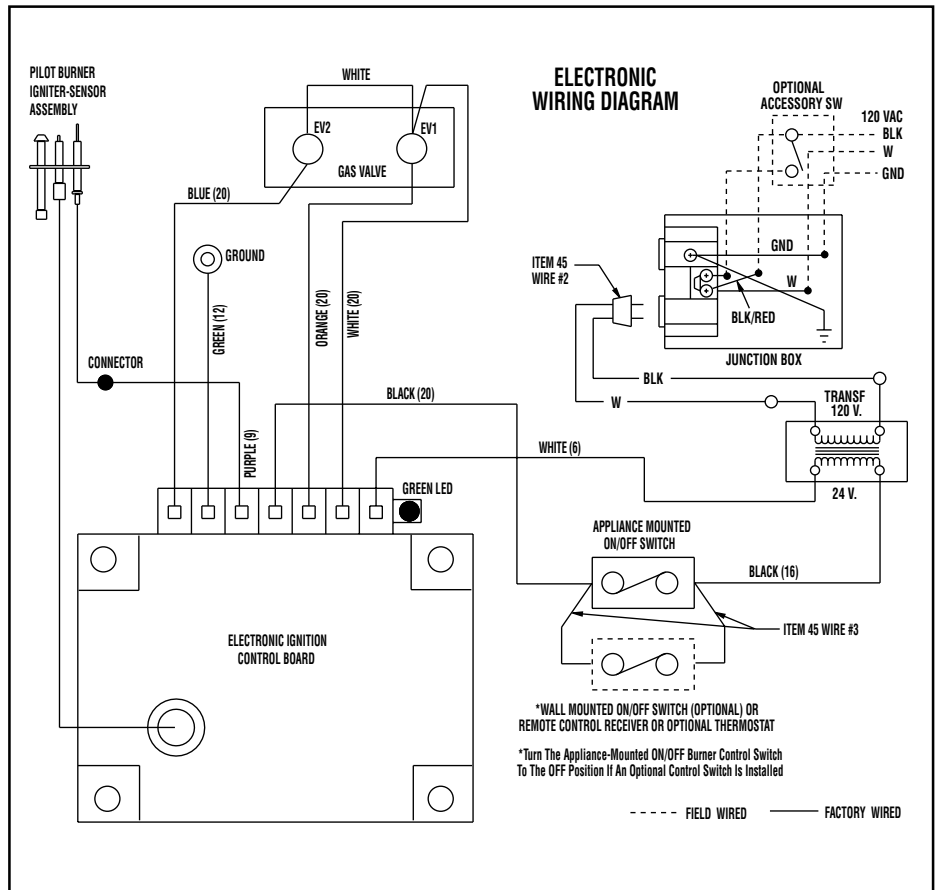
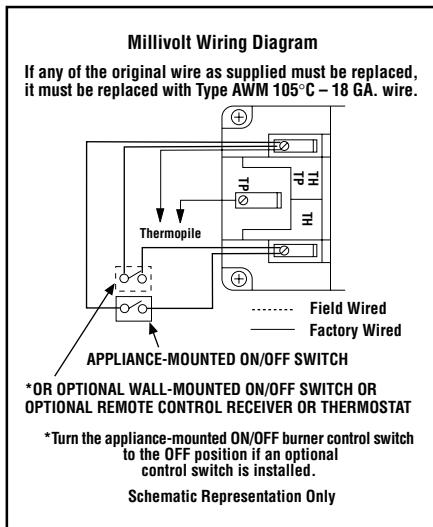

WARRANTY

Your gas appliance is covered by a limited twenty year warranty. You will find a copy of the warranty accompanying this manual. Please read the warranty to be familiar with its coverage.

Retain this manual. File it with your other documents for future reference.

PRODUCT REFERENCE INFORMATION

We recommend that you record the following important information about your fireplace. Please contact your Lennox dealer for any questions or concerns. For the number of your nearest Lennox dealer, please call 800-731-8101

Your Fireplace's Model Number _____

Your Fireplace's Serial Number _____

The Date On Which Your Fireplace Was Installed _____

The Type of Gas Your Fireplace Uses _____

Your Dealer's Name _____

REPLACEMENT PARTS

A complete parts list is found at the end of this manual. Use only parts supplied from the manufacturer.

Normally, all parts should be ordered through your Lennox distributor or dealer. Parts will be shipped at prevailing prices at time of order.

When ordering repair parts, always give the following information:

1. The model number of the appliance.
2. The serial number of the appliance.
3. The part number.
4. The description of the part.
5. The quantity required.
6. The installation date of the appliance.

If you encounter any problems or have any questions concerning the installation or application of this system, please contact your distributor, or Lennox directly:

LENNOX HEARTH PRODUCTS
1110 West Taft Avenue
Orange, CA 92865



LIGHTING INSTRUCTIONS – MILLIVOLT GAS VALVE

FOR YOUR SAFETY READ BEFORE LIGHTING

WARNING: IF YOU DO NOT FOLLOW THESE INSTRUCTIONS EXACTLY, A FIRE OR EXPLOSION MAY RESULT CAUSING PROPERTY DAMAGE, PERSONAL INJURY OR LOSS OF LIFE.

- A.** This appliance has a pilot which must be lighted with a piezo ignitor. When lighting the pilot, follow these instructions exactly.
- B. BEFORE OPERATING** smell all around the appliance area for gas. Be sure to smell next to the floor because some gas is heavier than air and will settle on the floor.
- WHAT TO DO IF YOU SMELL GAS**
- Extinguish any open flame.
 - Open windows.
 - Do not light any appliance.
 - Do not touch any electrical switches.
 - Do not use any phone in your building.
 - Immediately call your gas supplier from a neighbor's phone.
 - If your gas supplier cannot be reached, call the fire department.
- C.** Use only your hand to push in or turn the gas control knob. Never use tools. If the knob will not push in or turn by hand, do not try to repair it, call a qualified service technician. Force or attempted repair may result in a fire or an explosion.
- D.** Do not use this appliance if any part has been under water. Immediately call a qualified service technician to inspect the appliance and to replace any part of the control system and any gas control which has been under water.

LIGHTING INSTRUCTIONS

- 1. STOP!** Read the safety information above on this page.
- Set the thermostat to the lowest setting, if applicable.
- Turn off all electric power to the appliance, if applicable.
- Remove the control access panel.
- Push in gas control knob slightly and turn clockwise to "OFF."

- Wait five (5) minutes to clear out any gas. If you then smell gas, STOP! Follow "B" in the safety information above on this page. If you do not smell gas, go to the next step.
- Push in gas control knob slightly and turn counterclockwise to "PILOT."

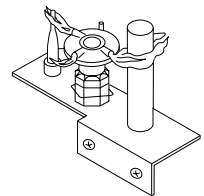
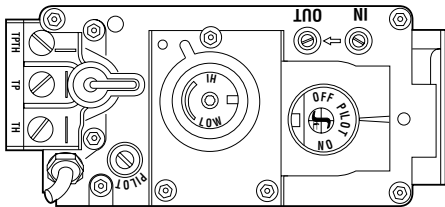
- Push in control knob all the way and hold in. Immediately light the pilot by triggering the spark ignitor (pushing the button) until pilot lights. Continue to hold the control knob in for about 1 ½ minutes after the pilot is lit. Release knob and it will pop back up. Pilot should remain lit. If it goes out, repeat steps 5 through 8.
 - If knob does not pop up when released, stop and immediately call your service technician or gas supplier.
 - If pilot will not stay lit after several tries, turn the control knob to "OFF" and call your service technician or gas supplier.
- Turn gas control knob counterclockwise to "ON."

- Close control access panel.
- Turn on all electric power to the appliance.
- Set thermostat to desired setting.

Note: Knob cannot be turned from "PILOT" to "OFF" unless the knob is pushed in slightly. Do not force.



TO TURN OFF GAS TO APPLIANCE

- Set the thermostat to the lowest setting.
- Turn off all electric power to the appliance, if service is to be performed.
- Remove control access panel.
- Depress gas control knob slightly and turn clockwise to "OFF." Do not force.

- Close control access panel.

LIGHTING INSTRUCTIONS — ELECTRONIC

FOR YOUR SAFETY READ BEFORE LIGHTING

WARNING: IF YOU DO NOT FOLLOW THESE INSTRUCTIONS EXACTLY, A FIRE OR EXPLOSION MAY RESULT CAUSING PROPERTY DAMAGE, PERSONAL INJURY OR LOSS OF LIFE.

A. When lighting the appliance, follow these instructions exactly.

B. BEFORE OPERATING smell all around the appliance area for gas. Be sure to smell next to the floor because some gas is heavier than air and will settle on the floor.

WHAT TO DO IF YOU SMELL GAS

- Extinguish any open flame.
- Open windows.
- Do not light any appliance.
- Do not touch any electrical switches.
- Do not use any phone in your building.

- Immediately call your gas supplier from a neighbor's phone.
- If your gas supplier cannot be reached, call the fire department.

C. Use only your hand to turn the gas control lever. Never use tools. If the lever will not turn by hand, do not try to repair it, call a qualified service technician. Force or attempted repair may result in a fire or an explosion.

D. Do not use this appliance if any part has been under water. Immediately call a qualified service technician to inspect the appliance and to replace any part of the control system and any gas control which has been under water.

LIGHTING INSTRUCTIONS

1. STOP! Read the safety information above on this page.

2. Turn remote wall switch to "OFF" or set the thermostat to lowest setting, if applicable.

3. Turn the ON/OFF switch to "OFF" if Step 2 is applicable, this ON/OFF switch should always be in the "OFF" position.

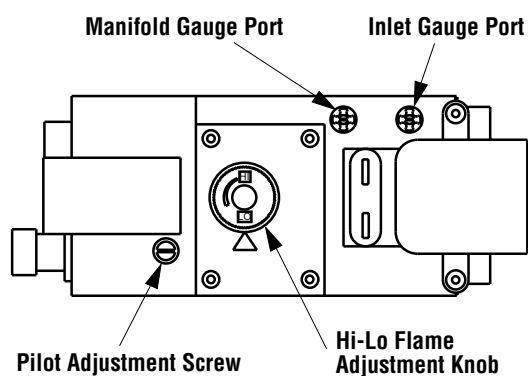

4. Verify main line shut-off valve is open.

5. This appliance is equipped with an ignition device which automatically lights the burner. Do Not try to light the burner by hand.

6. Wait five (5) minutes to clear out any gas. If you then smell gas, including near the floor, **STOP!** Follow "B" in the safety information above on this page.

7. Turn "ON" all electrical power to appliance (remote wall switch), or set the thermostat to the desired setting, if applicable.

8. Turn the ON/OFF switch on the appliance to "ON", if Step 7 is not applicable.

9. If the appliance will not operate, follow the instructions "To Turn Off Gas To Appliance" and call your service technician or gas supplier.

TO SHUT OFF

1. Turn off all electrical power to the appliance (remote wall switch) or set the thermostat to the lowest setting, if applicable.

TO TURN OFF GAS TO APPLIANCE

1. For complete shut-down, turn remote wall switch to "OFF" or set the thermostat to the lowest setting, if applicable.

2. Turn the ON/OFF switch to "OFF", if Step 1 is not applicable.

3. Close the main line shut-off valve.

TROUBLESHOOTING THE MILLIVOLT GAS CONTROL SYSTEM

Note: Before troubleshooting the gas control system, be sure external gas shut off valve (located at gas supply inlet) is in the "ON" position.

Important: Valve system troubleshooting should only be accomplished by a qualified service technician.

SYMPTOM	POSSIBLE CAUSES	CORRECTIVE ACTION
1. Spark ignitor will not light pilot after repeated triggering of ignitor button.	A. Defective ignitor (no spark at electrode).	Check for spark at electrode and pilot; if no spark and electrode wire is properly connected, replace ignitor.
	B. Defective or misaligned electrode at pilot (spark at electrode).	Using a match, light pilot. If pilot lights, turn off pilot and trigger the ignitor button again. If pilot lights, an improper gas mixture caused the bad lighting and a longer purge period is recommended. If pilot will not light – check gap at electrode and pilot – should be 1/8" to have a strong spark. If gap measures 1/8", replace pilot (Figure 8 on page 8).
	C. Gas supply pressure errant.	Check inlet gas pressure. It should be within the limits as marked on the rating plate.
	D. Pilot orifice plugged.	Clean or replace pilot orifice.
2. Pilot will not stay lit after carefully following the lighting instructions.	A. Defective pilot generator (thermocouple).	Check pilot flame, it must impinge on thermocouple (Figure 8 on page 8) Clean and/or adjust pilot for maximum flame impingement on thermocouple. Ensure that the connection between the valve and thermocouple are tight and secure.
3. Pilot burning, no gas to burner, Valve knob "ON," Wall Switch "ON."	A. Wall switch or wires defective.	Check wall switch and wires for proper connections. Jumper wire across terminals at wall switch, if burner comes on, replace defective wall switch. If okay, jumper wires across wall switch wires at valve, if burner comes on, wires are faulty or connections are bad.
	B. Thermopile may not be generating sufficient millivoltage.	Check thermopile with millivolt meter. Take reading at thermopile terminals of gas valve. Should read 325 millivolts minimum with optional wall switch "OFF." Replace faulty thermopile if reading is below specified minimum.
	C. Plugged burner orifice.	Check burner orifice for stoppage and remove.
4. Frequent pilot/burner outage problem.	A. Pilot flame may be too low or blowing (high) causing the pilot/valve safety to drop out.	Clean and/or adjust pilot flame for maximum flame impingement on thermocouple (Figure 8 on page 8).

TROUBLESHOOTING THE ELECTRONIC IGNITION SYSTEM

Note: Before troubleshooting, be sure that the appliance main line gas shut-off valve, the gas control valve and the wall switch are in the "ON" position.

Important: Valve system troubleshooting should only be accomplished by a qualified service technician.

SYMPTOM	POSSIBLE CAUSES	CORRECTIVE ACTION
1. Burner will not light.	A. Faulty Valve System.	See Below.
	B. "OFF/ON" or wall switch defective.	Disconnect the two black wires from the wire nuts. Test switch(s) for continuity with a multimeter. If continuity is not indicated, switch(s) is defective and must be replaced. Note: Before replacing "OFF/ON" switch, be sure to check wiring for loose connections or broken wires and repair as needed.
2. Burners come "ON" but go "OFF."	A. Burner orifice plugged.	Check main burner orifice(s) for stoppage. Clean or replace.
	B. Obstructed vent system.	Check vent system for obstructions.

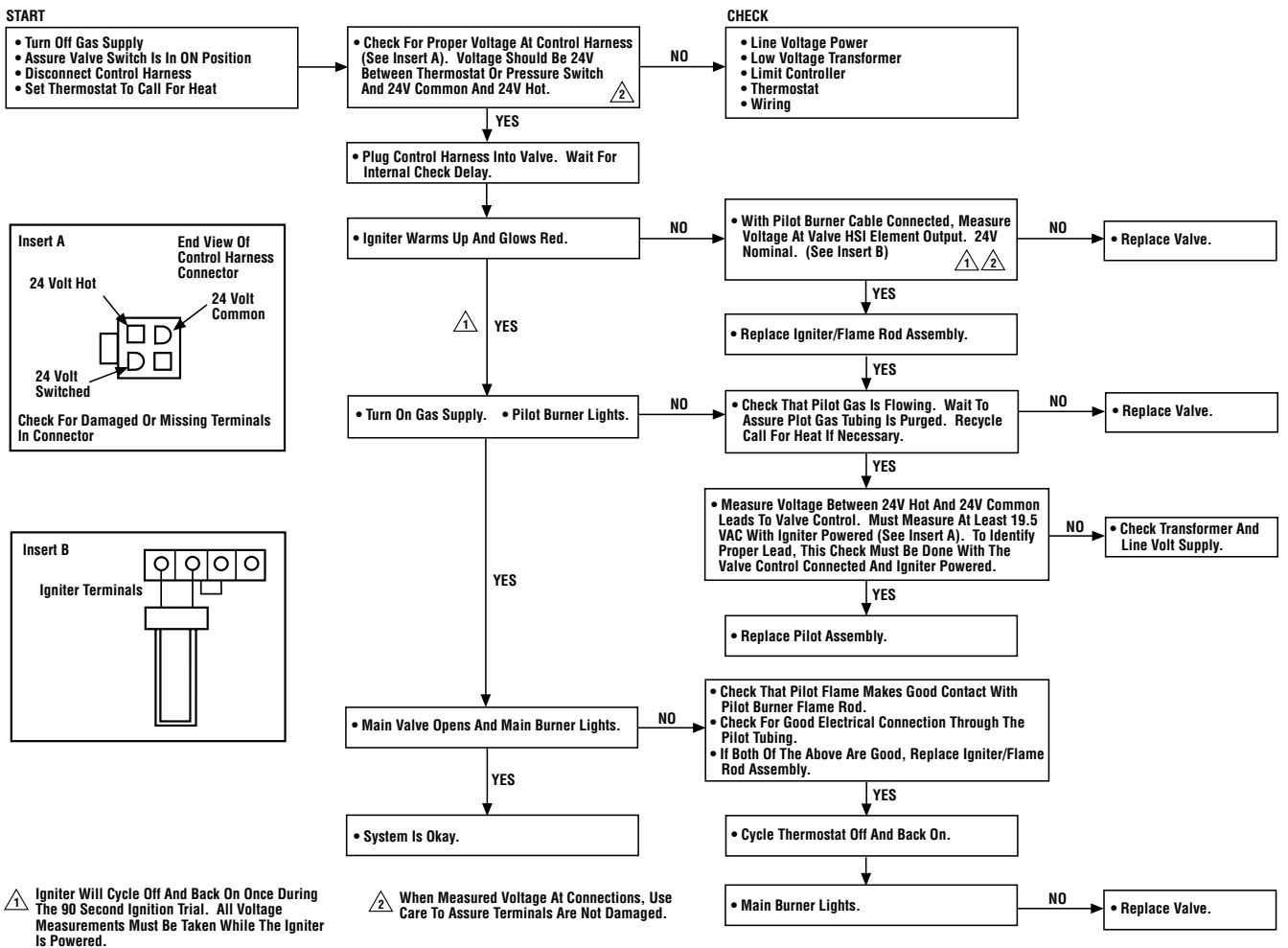

REPLACEMENT PARTS LIST

No.	DESCRIPTION	LSM40		LSM45	
		Part No.	Qty.	Part No.	Qty.
	Gas Fireplace Assembly	-	-	-	-
1.	Brick LIner Kit (a) - Rustic	H2219	1	H2223	1
	Brick Liner Kit (b) - Herringbone	H2220	1	H2224	1
	Brick LIner Kit (c) - Old Cottage	H2221	1	H2225	1
	Brick Liner Kit (d) - Black	H2222	1	H2226	1
2.	Bottom Brick Liner Kit	H2272	1	H2273	1
3.	Log Set	H1490	1	H1490	1
4.	Enclosure, Glass Door	H2281	1	H2282	1
5.	Spring Latch Assembly	H2274	2	H2274	2
6.	Burner Assembly	H2275	1	H2275	1
7.	Venturi	H1428	1	H1428	1
8.	Gasket - Venturi	43K85	1	43K85	1
9.	Access Plate	H2277	1	H2277	1
10.	Screen Rod	H2278	1	H2279	1
11.	Screen	H1427	2	H1169	2
12.	Gasket, Access Plate	H1452	1	H1452	1
13.	Gas Line Tubing	H2283	1	H2284	1
14.	Connector, Male	H2285	1	H2285	1
15.	Orifice - Natural Gas	H2286	1	H2288	1
15.	Orifice - Propane Gas	H2287	1	H2289	1
16.	Bag Of Rockwool	88L53	1	88L53	1
17.	Grate Assembly	H2290	1	H2290	1
18.	On/Off Control Switch	80L41	1	80L41	1
19.	Gas Line, Flexible Connection	93L32	1	93L32	1
20.	Modesty Panel - Right Side	H3371	1	H3372	1
21.	Modesty Panel - Left Side	H3373	1	H3374	1
22.	Floor Panel	H3369	1	H3370	1

GAS CONTROLS — SIT MILLIVOLT

No.	DESCRIPTION	Natural		Propane	
		Part No.	Qty.	Part No.	Qty.
30.	Gas Valve - SIT	43K0701	1	88J5301	1
31.	Piezo Igniter	10K8601	1	10K8601	1
32.	Pilot Assembly	H2291	1	H2292	1
33.	Pilot Generator	H2294	1	H2294	1
34.	Thermocouple	H2295	1	H2295	1
35.	Pilot Tube	H2296	1	H2296	1
36.	Electrode And Cable	H2297	1	H2297	1

GAS CONTROLS — SIT ELECTRONIC

No.	DESCRIPTION	Natural	
		Part No.	Qty.
40.	Gas Valve - SIT	99K8801	1
41.	Pilot Assembly	H2298	1
42.	Transformer	42J3201	1
43.	Ignition Modulal (With Wire Harness)	H1167	1

REPLACEMENT PARTS

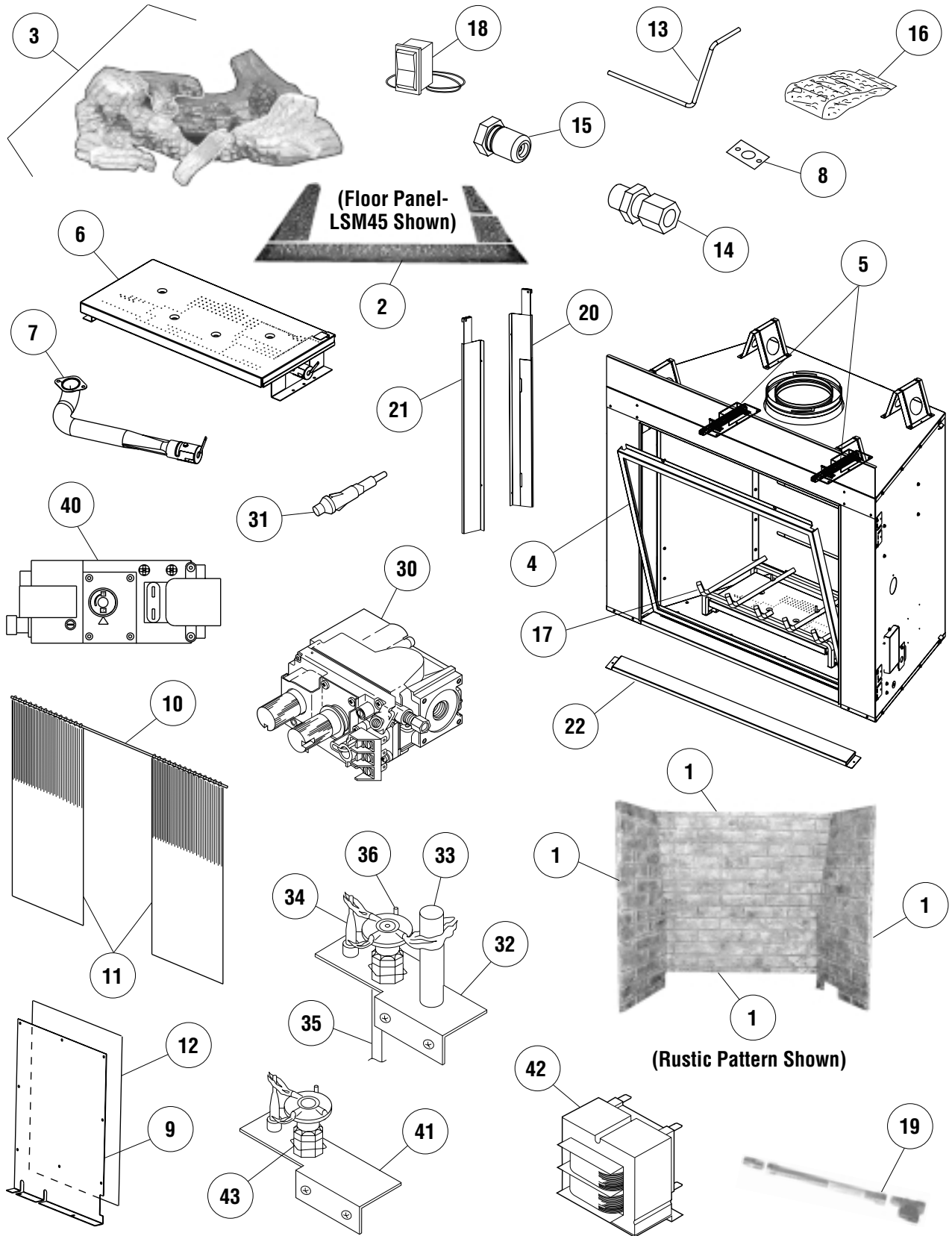

NOTE: DIAGRAMS & ILLUSTRATIONS NOT TO SCALE.

Lennox Hearth Products reserves the right to make changes at any time, without notice, in design, materials, specifications, prices and also to discontinue colors, styles and products. Consult your local distributor for fireplace code information.

Printed in U.S.A. © 2005 by Lennox Hearth Products

P/N 875,027M REV. A 06/2005

LHP
1110 West Taft Avenue • Orange, CA 92865