

LENNOX HEARTH TG301DV Owner's Manual

[Shop genuine replacement parts for LENNOX HEARTH
TG301DV](#)

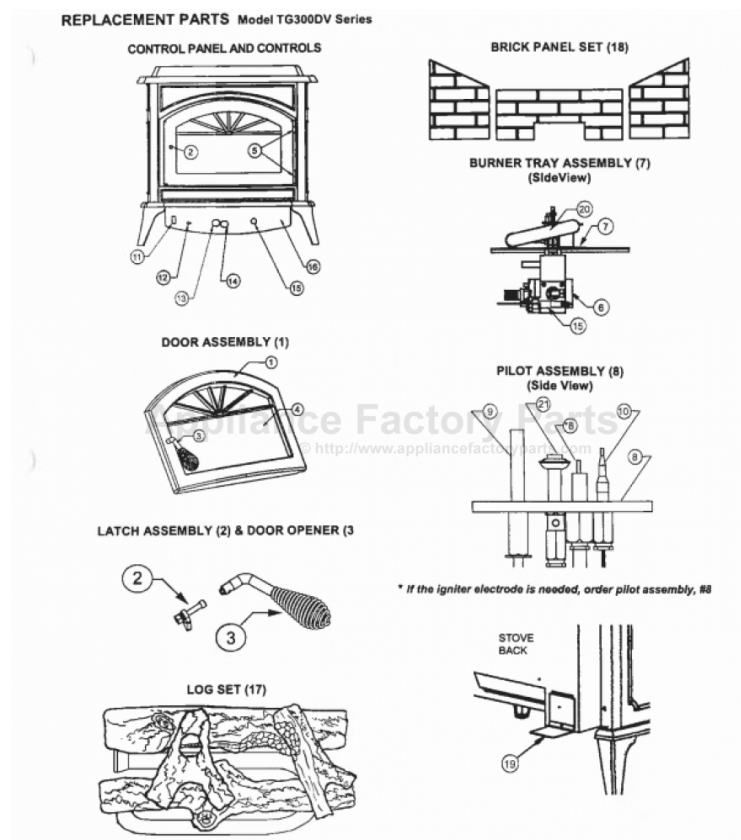

[Find Your LENNOX HEARTH Fireplace Parts - Select From 237 Models](#)

----- Manual continues below -----

TRADITIONS™
BY LENNOX HEARTH PRODUCTS

INSTALLATION AND OPERATION MANUAL

**FREESTANDING
GAS FIRED
DIRECT VENT
ROOM HEATER**

This appliance may be installed in an aftermarket permanently located, manufactured (mobile) home, where not prohibited by local codes.

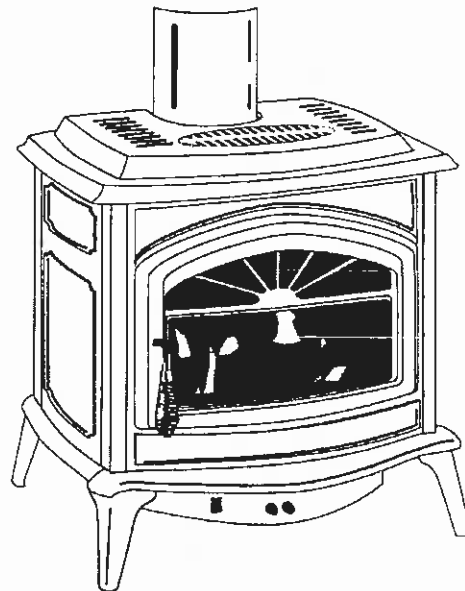

MODEL TG300DV Series (Direct Vent)

TG300DV - Painted Metallic Black TG301DV - Enamel Ebony Black
TG305DV - Enamel Hunter Green TG308DV - Enamel Mojave Sand

P/N 775036M, Rev. A, 01/02

WARNING

If the information in this manual is not followed exactly, a fire or explosion may result causing property damage, person injury or loss of life.

Do not store or use gasoline or other flammable vapors and liquids in the vicinity of this or any other appliance.

WHAT TO DO IF YOU SMELL GAS

- * Do not try to light any appliance.
- * Do not touch any electrical switch.
- * Do not use any phone in your building.
- * Immediately call your gas supplier from a neighbor's phone. Follow the gas supplier's instructions.
- * If you cannot reach your gas supplier, call the fire department.

Installation and service must be performed by a qualified installer, service agency or gas supplier. This appliance is only for use with the type(s) of gas indicated on the rating plate. This appliance is not convertible for use with other gases, unless a certified kit is used.

Warnock Hersey
CHUS
Report # 476-1527

IMPORTANT WARNINGS / CAUTIONS

CAUTION: Read this manual thoroughly before starting installation. For your safety, follow the installation, operation and maintenance instructions exactly without deviation. Failure to follow these instructions may result in a possible fire hazard and may void the warranty. If this appliance is not properly installed, a house fire may result. Contact local building or fire officials about restrictions and installation inspection in your area.

1. **WARNING:** Improper assembly, installation, adjustment, alteration, service or maintenance can cause injury and / or property damage. Installation and service must be performed by a qualified installer, service agency or the gas supplier. Except when complying with local codes, any deviation from the installation and/or operating instructions contained in this manual will void the appliance warranty and may be hazardous.
2. Due to high temperatures, this appliance should be located out of traffic and away from furniture, draperies and not in windy or drafty areas.
3. The appliance must NOT be connected to a chimney flue serving a solid-fuel burning appliance.
4. This appliance is equipped with a combustion chamber pressure relief door (See *Combustion Chamber Pressure Relief Door*, page 20), in case of delayed ignition blow back. If the relief door opens, inspect for gasket damage. If necessary, replace with factory supplied gasket only. Confirm relief door is closed and properly seated.
5. **CAUTION: HOT WHILE IN OPERATION.** An appliance hot enough to warm your home can severely burn anyone touching it. Keep children, clothing and furniture away. Contact may cause skin burns. Do not let children touch the appliance. Train them to stay a safe distance from the unit.
6. Do not place clothing or other flammable material on or near the gas appliance. The minimum clearances must be maintained for all combustible surfaces and materials including; furniture, carpet, drapes, clothing, wood, papers, etc.
7. Do not connect 110-12 VAC (residential line voltage) to the gas control valve or control wiring system of the unit.
8. Any safety screen or guard removed for servicing must be replaced prior to operating the appliance.
9. **WARNING:** Use only the glass door certified with this appliance. Exercise caution to protect glass from impact. Do not operate the appliance with broken glass or use substitute materials.
10. **DO NOT USE** this appliance if any part has been under water. Immediately call a qualified service technician to inspect the appliance and replace any part of the control system and gas control which has been under water.
11. Do not burn wood or other material in this heater.
12. **WARNING:** The appliance area must be kept clear and free from combustible materials, gasoline and other flammable vapors and liquids.
13. Do not use a blower insert, heat exchanger insert or other accessory not approved for use with this appliance.
14. This appliance is not for use with air filters.
15. Any change to this heater or its controls can be dangerous.
16. The appliance should be inspected and maintained at least annually by a professional service person. More frequent cleaning may be required due to excessive lint from carpeting, bedding material, etc. It is imperative that control compartments, burners and circulating air passageways of the appliance be kept clean.
17. This appliance is only for use with the type of gas indicated on the rating label (located inside control panel). This appliance may be field converted from natural gas to propane, or propane to natural gas only if an approved conversion kit is used.
18. **WARNING:** This appliance must be properly connected to a venting system. Operation of this gas appliance when not connected to a properly installed and maintained venting system can result in carbon monoxide (CO) poisoning and possible death.
19. **WARNING:** Do not modify the venting system, appliance, or controls in any way. Be advised, any modification can be dangerous. Provisions must be made to ensure the intake and exhaust passages of the vent termination cap remain unrestricted.
20. **CAUTION:** Under no circumstances should these appliances be vented to other rooms or buildings. These appliances must only be vented to the outside. Vent terminations shall not be recessed into a wall or siding.
21. **IMPORTANT:** Do not exceed the maximum horizontal run allowed.
22. **SAVE THESE INSTRUCTIONS.**

TABLE OF CONTENTS

Important Warnings	2
Testing / Listing, Using this Manual	3
Planning Your Installation	4-6
Manufactured (Mobile) Home Installation	6
Installation	7-16
Care and Operation.....	17-19
Maintenance.....	20-24
Wiring Diagrams.....	24
Troubleshooting.....	25-27
Replacement Parts.....	28-29
Optional Accessories.....	30
Specifications	31
Safety / Listing Label.....	32
Ownership Record and Service Log	33

TESTING / LISTING

This appliance is tested and certified as safe for residential use by an internationally recognized testing and certification agency. The safety tests are conducted in accordance with American National Standards Institute (ANSI) requirements. The Traditions™ Model TG300DV has been tested and certified by ITS (Intertek Testing Services. Listing mark is Warnock Hersey). It is listed as a Direct Vent, Gas Fired Room Heater to:

Tested to ANSI Standards, Z21.44-1995 Gas Fired Gravity and Fan type Direct Vent Wall Furnace and applicable sections of CAN 1-2.19-M81 Gas Fired Direct Vent Wall Furnace, Z21.50-1996/CGA 2.22-M96 Decorative Gas Appliances, CAN/CGA-2.17-M91 Gas Fired Appliances for use at high altitudes, UL307B Gas Burning Heating Appliances for manufactured homes (mobile homes).

Vent Brands:

This appliance is listed for installation with Security Secure Vent chimney or Simpson Dura Vent brand chimney only. Other brands may not be used. See pages 7 to 11.

USING THIS MANUAL

Please read and carefully follow all of the instructions found in this manual. Please pay special attention to the safety instructions provided in this manual. Following the Homeowner's Care and Operation Instructions included here will assure that you have many years of dependable and enjoyable service from your appliance.

CONGRATULATIONS ON THE PURCHASE OF YOUR NEW GAS APPLIANCE MANUFACTURED BY LENNOX HEARTH PRODUCTS.

When you purchased your new gas fired heater, you joined the ranks of thousands of concerned individuals whose answer to their home heating needs reflects their concern for aesthetics, efficiency and our environment. We extend our continued support to help you achieve the maximum benefit and enjoyment available from your new gas fired heater.

It is our goal at Lennox Hearth Products to provide you, our valued customer, with an appliance that will ensure you years of trouble free warmth and pleasure.

Thank you for selecting a Lennox Hearth Products gas fired heater as the answer to your home heating needs.

Sincerely,
All of us at Lennox Hearth Products

PACKAGING LIST

This appliance is packaged with an accessory package, which contains the following:

- One - Installation and operation instructions manual.
- One - Warranty.
- Three- Vent restrictor rings.
- One - Allen-head door opener.
- One - Bracket, remote control sensor (only needed if optional remote control is purchased).
- One - Trivet, black decorative (for stove top).
- One - Log set, four-piece (with glowing embers-rock wool).

PLANNING YOUR INSTALLATION

LOCAL AND NATIONAL CODE REQUIREMENTS

The installation of these appliances must conform with local codes or, in the absence of local codes, with:

In USA, The National Fuel Gas Code, ANSI Z223.1 (NFPA 54) - current edition.

In Canada, CAN/CGA-B149.1 (Installation Code for Natural Gas Burning Appliances and Equipment-current edition) and CAN/CGA-B149.2 (Installation Code for propane Gas Burning Appliances and Equipment-current edition) and other applicable codes.

Optional Blower Kit, (see page 30): The blower electrical power cord should be connected to a standard 115 volt, A.C., 60 hertz cycle, electrical outlet (wall receptacle) that is electrically grounded per local codes or per electrical codes:

In USA, NEC, ANSI / NFPA 70-1987.

In Canada, CSA C22.1

WARNINGS:

Electrical Grounding Instructions. This optional blower kit is equipped with a three-prong (grounding) plug for your protection against shock hazard and should be plugged directly into a properly grounded three-prong receptacle. Do not cut or remove the grounding prong from this plug.

To avoid electrical shock, always ensure that the power cord is unplugged (i.e., there is no electrical power to the circulation blower) before handling the circulation blower or performing any work on the appliance.

High Altitude: Gas inputs shown are for elevations up to 2000 feet in the U.S.A. and 4500 feet in Canada. For higher elevation, the appliance must be derated (see *Deration* below).

Deration: Replacing burner orifice with a smaller one to reduce input. Ratings must be reduced at the rate of 4 percent for each 1,000 feet above sea level. Refer to (for USA) NFPA 54 / ANSI Z223.1-latest edition for orifice resizing. See page 30 for information on a high altitude orifice kit.

TOOL / EQUIPMENT LIST

The following tools and equipment are recommended for completing the partial assembly required when the appliance is installed:

- 1/4" wrench.
- 1/4", 5/16" and 3/8" drivers or sockets.
- Pipe wrench.
- Phillips head screwdriver.
- Flat head screwdriver.
- Pipe sealant compound.
- Leak test fluid.
- "U" tube manometer or pressure gauge (0 - 16 inches water column) H₂O scale.

GAS PRESSURE (WC = Water Column)

Inlet gas supply pressure for proper operation

Natural Gas - 4.5" WC min. - 10.5" WC max.
Propane (LP) - 10.5" WC min - 13.0" WC max.

Manifold gas supply pressure:

	LOW	HIGH
Natural Gas - 1.7" WC	(to) 23,700 BTU/hr	3.5" WC 40,000 BTU/hr
Propane (LP) 6.3" WC	(to) 30,000 BTU/hr	10" WC 40,000 BTU/hr

PRESSURE TAPS

Gas Inlet Pressure Tap - Located on bottom left of gas valve.

Gas Outlet (Manifold) Pressure Tap - Located on bottom left of gas valve (to the right of the inlet pressure tap).

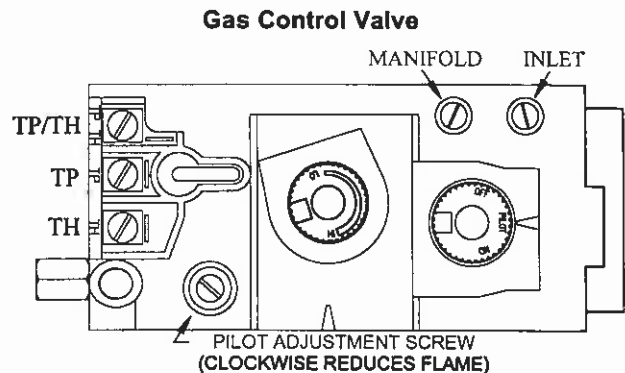

Pressure Testing: See *Pressure Testing* on page 12.

▲ IMPORTANT

Appliance gas valves can be damaged if subjected to more than 1/2 psig (3.48 kPa) pressure. Therefore, when pressure testing the gas supply piping system in this pressure range, the appliance gas valve must be disconnected and isolated.

PLANNING YOUR INSTALLATION

QUESTIONS TO ASK LOCAL BUILDING OFFICIAL

Correct installation is critical and imperative for reducing fire hazards and perilous conditions that can arise when gas appliances function improperly. The appliance must be installed per manufacturers' instructions.

Gas appliance equipment and installations must conform to appropriate local codes and applicable state and federal requirements. Familiarity with these requirements before installation is essential. Important considerations to discuss with local building officials include:

1. Applicable codes (i.e. Uniform Mechanical Code, State or Regional Gas Codes, National Fuel Gas Code)?
2. Local amendments?
3. Recognized testing lab: I.T.S. / Warnock Hersey.
4. Is a permit required - cost?
5. In some states or municipalities, a licensed gas fitter or plumber may be required to install this appliance. Check with your local building official for requirements in your area (i.e. Is a license required for installation of gas supply line)?
6. Maximum amount of gas pipe without a pressure test - type of test required?
7. Are below grade penetrations of the gas line allowed?
8. Is concealed gas piping allowed?
9. Specific requirements of concealed fittings?
10. Is rigid pipe to appliance required?
11. Allowed piping materials?
12. Shut-off valve required within 4 feet of the firebox?
13. May the shut-off valve be concealed?
14. Rooms where the installation is not allowed?

In the absence of local codes, installation should conform to the National Fuel Gas Code, also known as ANSI Z223.1-NFPA 54.

PLANNING YOUR INSTALLATION

CLEARANCES TO COMBUSTIBLE MATERIALS

This appliance can be installed in most residential room configurations, parallel to a rear or adjacent wall, or in an alcove that allows for the minimum clearances to combustibles surfaces. Your local building inspector should review your plans prior to installation.

When installing this appliance, provide adequate clearances around air openings and adequate clearances for purposes of servicing and proper operation.

As determined through the safety certification of this unit, a minimum clearance to combustibles materials must be maintained around specific areas of the gas appliance. (Refer to Figures 1 through 3)

The clearances listed here are minimum distances and only apply in the configuration shown. Do not use clearances from one installation configuration with clearances from another to obtain closer clearances.

Top of appliance (min.) 31 1/4" (inches)
This includes any projections such as shelves, window sills, mantels, etc. above the appliance.

Back Wall (min.) 5" (inches)

Side Wall (min.) 5" (inches)

Corner - 45° angle (min.) 5" (inches)
 stove corners to wall

Ceiling (min.) 60" (inches) from floor

Alcove Height (min.) 60" (inches) from floor

Alcove Width (min.) 37 3/4" (inches)

Alcove Depth (max.) 48" (inches)

Floor (min.) 0" (inches)

Wall Thickness (max.) 31" (inches)

Note: min. = Minimum, max. = Maximum.

MANUFACTURED (MOBILE) HOME REQUIREMENTS

Model TG300DV may be installed in an aftermarket permanently located, manufactured home, where not prohibited by local codes. When installed in Manufactured Housing the following supplemental requirements must be met:

- The appliance must be secured to the floor (i.e. use (4) 1/4" x 2 3/4" bolts and nuts or equivalent. Note: Not included) for securing appliance to the manufactured home floor.
- The appliance must be grounded to the chassis of the manufactured home. Use a No. 8 or heavier copper wire at least 18" in length.
- The structural integrity of the manufactured home floor, walls, ceiling and roof must be maintained.
- A manufactured (mobile) home installation must conform with the Manufactured Home Construction and Safety Standard, Title 24 CFR, Part 3280, or, when such a standard is not applicable, the Standard for Manufactured Home Installations, ANSI / NCSBCS A225.1, or standard for Gas equipped Recreational Vehicles and Mobile Housing, CSA Z240.4.

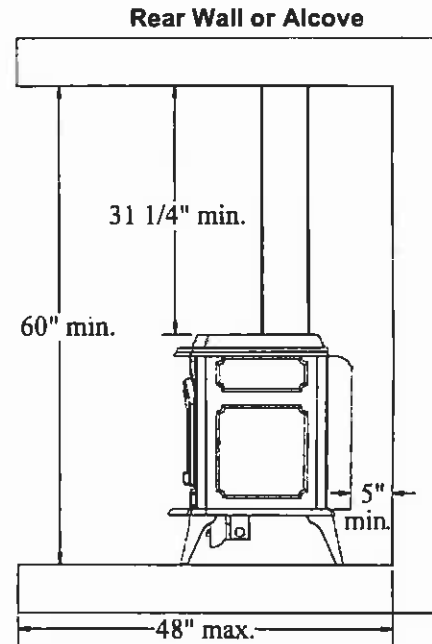

Fig. 1

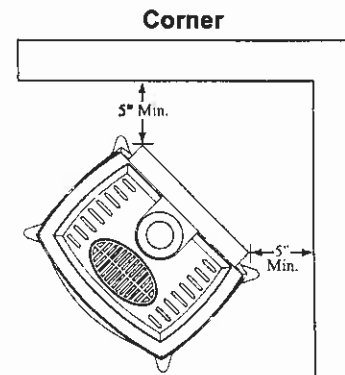

Fig. 2

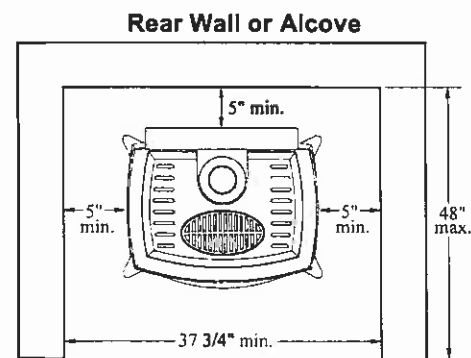

Fig. 3

FLOOR PROTECTION

When installed directly on carpeting, tile (see "•" note below) or other combustible material other than wood flooring, the appliance shall be installed on a metal or wood panel extending the full width and depth of the stove body.

Notes:

- Ceramic tile is non-combustible and does not require a wood or metal panel under the appliance.

INSTALLATION

VENTING CONFIGURATIONS

This appliance is approved to be installed in the following 3 venting configurations (no other venting configurations are allowed):

- Horizontal Termination with 1 offset (see page 8).
- Vertical Termination with 2 Offsets (see page 8).
- Vertical Termination with no Offsets (see page 9).

Look at the applicable venting configurations shown on pages 8 and 9 for additional requirements which are specific for each venting configuration.

General Venting Requirements

- This appliance is designed to be vented with a 4" x 6 5/8" co-axial direct-vent pipe. Each direct-vent appliance must use its own separate vent system (see page 10 for approved vent components). See pipe manufacturers instructions for additional vent installation requirements.
- Horizontal run of pipe requires a 1/4" rise per foot.
- See page 11 for *Vent Termination Requirements*.
- Horizontal vent clearances: 3" minimum top 1" minimum on bottom and sidewalls.
- Vertical vent clearances: 1" minimum.

FLUE RESTRICTOR RING(S) INSTALLATION

There are three 3/8" restrictor rings provided with this appliance. The standard placement is outlined on pages 8 & 9 (install first ring after 6' of vertical pipe, then every 4' thereafter, not to exceed 3 restrictor rings. See *Restrictor Ring Placement Guidelines* on this page for more information). Install the restrictor ring(s) between the locking sections of pipe.

Note: The restrictor rings are designed to slow down the combustion air delivery. By reducing the air delivery, the performance and flame aesthetics of the appliance is improved.

Restrictor Ring Placement Guidelines

Depending upon the vent configuration and other variables, it may be necessary to adjust the quantity and position of the restrictor ring(s) to ensure proper operation of the appliance.

Be advised, product performance can be affected due to numerous factors which affect exhaust flow and air delivery, such as – gas BTU value and composition, type of gas used (NG or LP), vent configuration, ambient temperature, wind conditions, altitude, etc.

Symptoms for Lack of Combustion Air - Remove restrictor ring(s) to increase combustion air delivery if the following symptoms are present (first confirm input is correct, primary air shutter is properly adjusted, and venting system connections are secure and not blocked):

- Flame appears yellow with black tips.
- Floating or reaching burner flames (lazy, ill-defined, quiet, may roll).
- Sooting.
- Pilot becomes yellow and appliance shuts down.

Symptoms - Excessive Combustion Air - Install one or more restrictor ring(s) to reduce combustion air delivery if the following symptoms are present:

- Low Flame.
- Pilot pulls and appliance shuts down.
- Waving blue pilot flame.

Support Brackets - Install vent support brackets as specified by vent manufacturer.

Ref. NFPA 54 / ANSI Z223.1, 7.6.5

Support of Gas Vents. Gas vents shall be supported and spaced in accordance with their listings and the (vent) manufacturer instructions.

INSTALLATION

VENTING CONFIGURATIONS WITH HORIZONTAL PIPE RUNS

Maximum allowable horizontal pipe run:

At 3' (foot) vertical pipe, the maximum horizontal run allowed is 3' (feet). At 22' vertical pipe, the maximum horizontal run allowed is 10'. For vertical height distances between 3' (feet) and 22' (feet) refer to chart (to the right) to determine the maximum horizontal run allowed.

Maximum Horizontal Pipe Runs for Given Vertical Pipe Run (in feet)

Minimum Vertical Pipe	Maximum Horizontal run allowed	Minimum Vertical Pipe	Maximum Horizontal run allowed
3'	3'	14'	7'
6'	4'	16'	8'
8'	5'	19'	9'
11'	6'	22'	10'

HORIZONTAL TERMINATION WITH 1 OFFSET

Min. Vertical Pipe From Appliance to Offset: 3 feet.

Max. Vertical Pipe Length: 22 feet

Min. Horizontal – 1' (clearance to rear wall plus wall thickness).

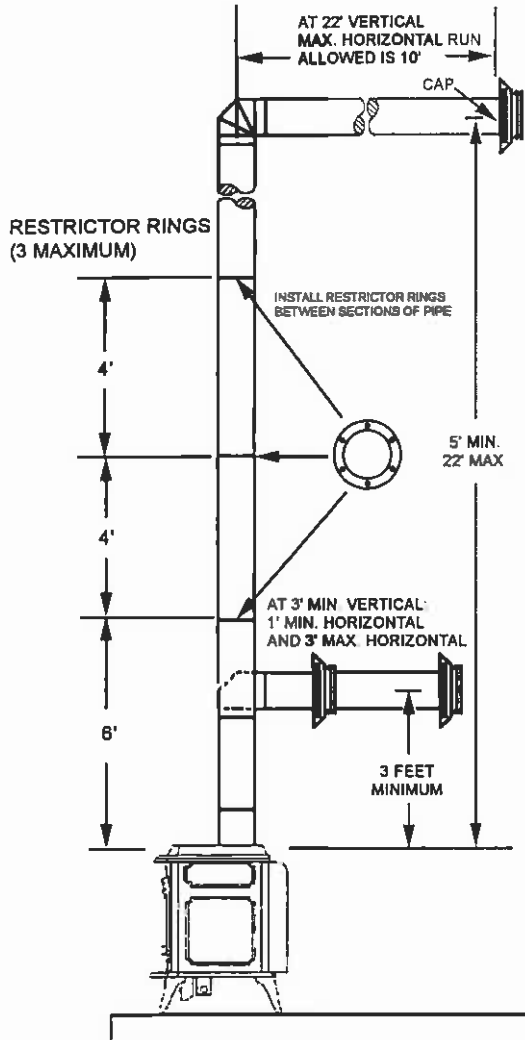

VERTICAL TERMINATION WITH 2 OFFSETS

Min. Vertical Pipe From Appliance to First Offset: 3 feet.

Max. Vertical - 22' (feet)

Min. Total Vertical Pipe Length: 5 feet

Max. Total Vertical Pipe Length: 22 feet

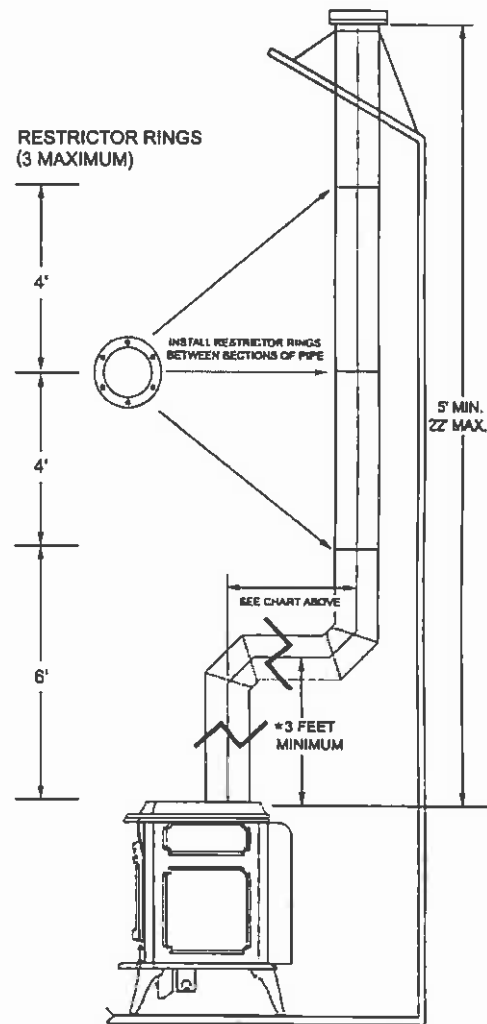

INSTALLATION

VERTICAL TERMINATION WITH NO OFFSETS

Min. Vertical Pipe Length: 5 feet

Max. Vertical Pipe Length: 22 feet

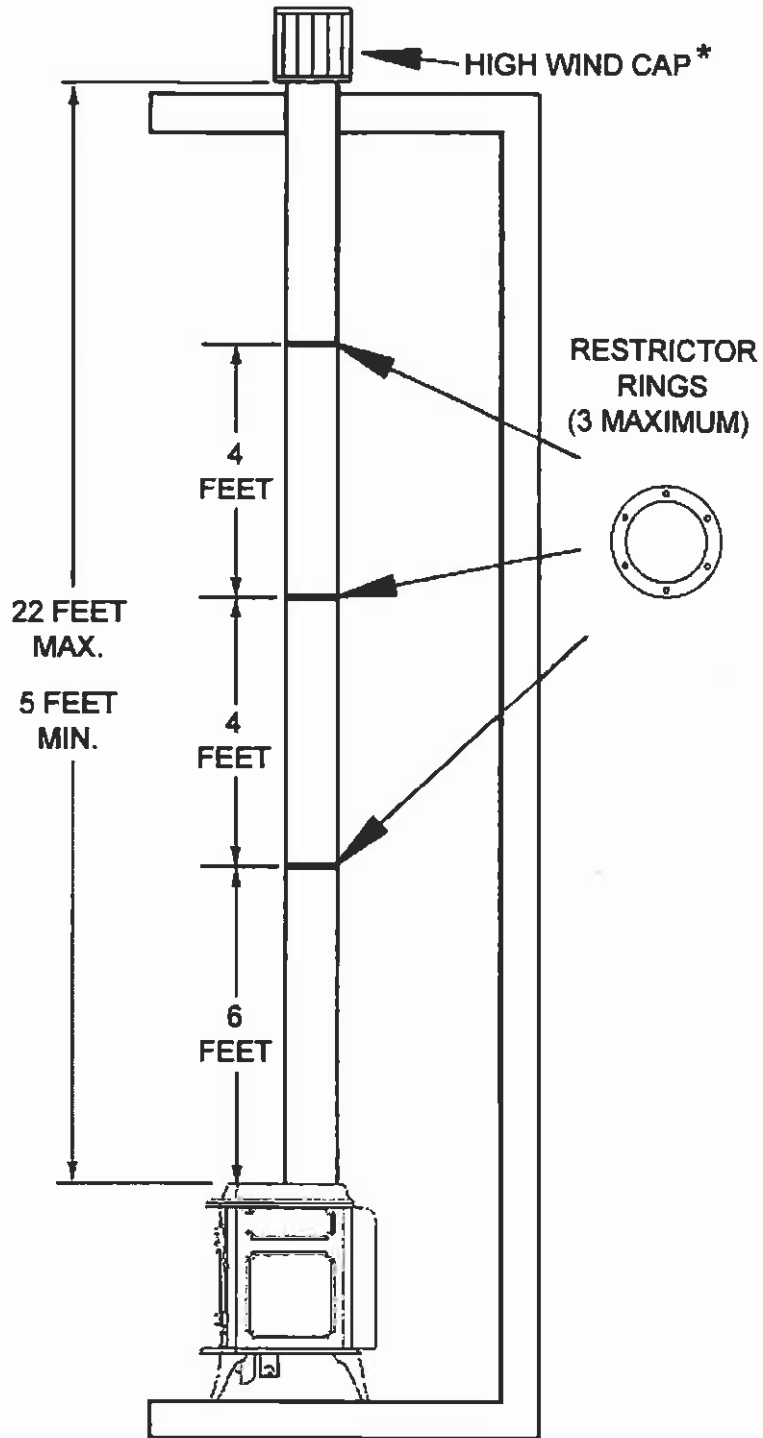

* A high wind cap is required when terminating vertical.

INSTALLATION See *Pipe Manufacturers Instructions For Installation Of Venting Components & Clearances.*
DIRECT VENT SYSTEM COMPONENTS – Model TG300DV

The following Direct-Vent system components may be safely used with this appliance.

IMPORTANT: APPLIANCES INSTALLED USING SIMPSON DURA-VENT BRAND PIPE MUST SEAL ALL JOINTS WITH MILL-PAC BLACK, HIGH TEMPERATURE SEALANT.

Model #	Brand: SECURITY / Description	Model #	Brand: SIMPSON DURA-VENT / Description
SV 0 SHK	Standard Horizontal Term. Kit (90° Black Elbow, Firestop (2), Horizontal Square Term. Cap)	970	Basic Horizontal Term. Kit (90° Black Elbow, Wall Thimble Cover, Horizontal Square Term. Cap)
SV 0 HK	Horizontal Term. Kit (90° Black Elbow, Firestop (2), Horizontal Term. Cap, adj. Black length 1-1/2 – 6")	971	Horizontal Term. Kit A (90° Black Elbow, Wall Thimble Cover, Horizontal Square Term. Cap, adj. 24" black pipe, 11-14 5/8" adj. Black pipe)
SV 0 FK	Vertical Flat Roof Term. Kit (w/flashing, storm collar, vertical Term. Cap)	973	Vertical Termination Kit
SV 0 FAK	Vertical pitched Roof Kit, 1/12-7/12 (with adjustable roof flashing, storm collar, vertical termination cap)	978	Vertical Pitched Roof Kit, 0/12-6/12 (with adjustable flashing, storm collar, low profile term. Cap)
SV 0 FBK	Vertical pitched Roof Kit, 8/12-12/12 (with adjustable roof flashing, storm collar, vertical termination cap)	N/A	N/A
SV 0 L6	6" Pipe Length (Galvalume)		6" Pipe Length (Galvalume)
SV 0 LB6	6" Pipe Length (Black)	908B	6" Pipe Length (Black)
SV 0	9" Pipe Length (Black)	907B	9" Pipe Length (Black)
SV 0 L12	12" Pipe Length (Galvalume)	906	12" Pipe Length (Galvanized)
SL 0 LB12	12" Pipe Length (Black)	906B	12" Pipe Length (Black)
SV 0 L24	24" Pipe Length (Galvalume)	904	24" Pipe Length (Galvanized)
SV 0 LB24	24" Pipe Length (Black)	904B	24" Pipe Length (Black)
SV 0 L36	36" Pipe Length (Galvalume)	903	36" Pipe Length (Galvanized)
SV 0 LB36	36" Pipe Length (Black)	903B	36" Pipe Length (Black)
SV 0 L48	48" Pipe Length (Galvalume)	902	48" Pipe Length (Galvanized)
SV 0 LB48	48" Pipe Length (Black)	902B	48" Pipe Length (Black)
N/A	N/A	911B	11"-14" Adj. Pipe Length (Black)
SV 0 LA	1 1/2- 6" Adj. Pipe Length	N/A	N/A
SV 0 LBA	1 1/2- 6" Adj. Black Pipe Length	N/A	N/A
SV 0 E45	45 Elbow (Galvalume)	945	45 Elbow (Galvanized)
SV 0 EB45	45 Elbow (Black)	945B	45 Elbow (Black)
SV 0 E90	90 Elbow (Galvalume Swivel)	990G	90 Elbow (Galvanized Swivel)
SV 0 EB90	90 Elbow (Black Swivel)	990BG	90 Elbow (Black Swivel)
SV 0	90 Elbow (Galvalume)	990	90 Elbow (Galvanized)
SV 0	90 Elbow (Black)	990B	90 Elbow (Black)
SV 0 CHC	⊕Horizontal Standard Term. Cap	984	⊕Horizontal Standard Term. Cap
SV 0 CHCV	⊕Horizontal High Wind Term. Cap	N/A	⊕Horizontal High Wind Term. Cap
SV 0 CGV	• Vertical High Wind Cap	991	• Vertical High Wind Cap
SV 0 STC36	⊗Snorkel Termination Cap 36"	981	⊗Snorkel Termination Cap 36"
SV 0 STC14	⊗Snorkel Termination Cap 14"	982	⊗Snorkel Termination Cap 14"
SV 0	Vinyl Shield Protector	950	Vinyl Siding Standoff
SV 0 VS	Round Ceiling Support / Wall Thimble Cover	940	Round Ceiling Support / Wall Thimble Cover
SV 0 CSB	Cathedral Ceiling Support Box, decorative square	941	Cathedral Ceiling Support Box
SV 0 SF	Black Plate, Decorative	N/A	N/A
SV 0	Round Ceiling Support Box/Wall Thimble	942	Round Ceiling Support Box/Wall Thimble
SV 0	Storm Collar	953	Storm Collar
SV 0 RSM	Wall Radiation Shield	N/A	N/A
SV 0 BF	Firestop	N/A	N/A
N/A	N/A	963	Firestop Spacer
SV 0 F	Flashing, Flat Roof (storm collar included)		
SV 0 FA	Flashing, Adjustable roof 1/12-7/12 (storm collar included)	943	Flashing 0/12-6/12
SV 0 FB	Flashing, Adjustable 8/12-12/12 (storm collar included)	943S	Flashing 7/12-12/12
SV 0 BM	Wall Band	988	Wall Strap

- ⊗ Snorkel Caps: These are elongate vent termination caps, which incorporate the principles of natural draft into a horizontal installation. Two styles are common, 14" and 36" (Cap height). They enhance draft and relieve backpressure by creating natural draft in the snorkel.
- ⊕ Horizontal Caps: This 13 1/2" square horizontal cap is placed on the outer wall of the dwelling. Not to be within 9" of an air inlet or within 12" of the ground. It requires a minimum 2' rise on the interior pipe.
- Vertical Termination Cap: Low profile and high wind caps can only be used on vertical pipe installations.

INSTALLATION

DIRECT VENT RETROFIT OF EXISTING CHIMNEY SYSTEM - An existing Class-A (wood-burning) Metal Chimney or Masonry Chimney can be converted to a direct vent system. Use one of the following chimney conversion kits listed below. Have the existing chimney system inspected by a professional prior to the conversion. **If using Simpson Dura-Vent brand liner kit, see "IMPORTANT" note at the top of page 10.** The chimney conversion should not be applied to the portion of the vent system that is in the room of the appliance. Use only Co-Axial direct vent pipe (4" inner pipe, 6 5/8" outer pipe as listed on page 10) from the appliance to the retro-connector into converted flue system. Adhere to all specifications outlined in this manual regarding clearances to combustibles, vertical and horizontal vent length minimums and maximums, etc. Read all instructions in this manual and provided by vent manufacturer with kit carefully before starting the installation (see pages 6 – 9). Failure to follow the instructions may create a fire or other safety hazard, and will void the warranty.

Model #	Brand: SECURITY / Description	Model #	Brand: SIMPSON DURA-VENT / Description
SV4MCK	Masonry Chimney Conversion Kit –Vertical term. Cap, cap adapter, masonry cover, black adapter (to flex), 2 gear clamps	934	Masonry Chimney Conversion Kit
SV4CCK1	Factory Built Chimney Conversion Kit – for 6" I.D., 1" insulation.	931	Factory Built Chimney Conversion Kit A – for 6" I.D.; Only compatible w/specific brands – Contact Vent Manufacturer
SV4CCK2	Factory Built Chimney Conversion Kit – for 7" I.D., 1" insulation; 8" I.D., 1" insulation; 6" I.D., 2" insulation.	932	Factory Built Chimney Conversion Kit B – for 6", 7" & 8" I.D.; Only compatible w/specific brands – Contact Vent Manufacturer
SV4CCK3	Factory Built Chimney Conversion Kit – for 10" I.D., 1" insulation; 7" I.D., 2" insulation; 8" I.D., 2" insulation.	933	Factory Built Chimney Conversion Kit C – for 7" & 8" I.D.; Only compatible w/specific brands – Contact Vent Manufacturer

VERTICAL VENT TERMINATION REQUIREMENTS

The vent/air intake termination clearances above the high side of an angled roof is as follows:

Roof Pitch	Feet	Meters
Flat to 6/12	1.0	0.3
6/12 to 7/12	1.25	0.38
7/12 to 8/12	1.5	0.46
8/12 to 9/12	2.0	0.61
9/12 to 10/12	2.5	0.76
10/12 to 11/12	3.25	0.99
11/12 to 12/12	4.0	1.22
12/12 to 14/12	5.0	1.52
14/12 to 16/12	6.0	1.83
16/12 to 18/12	7.0	2.13
18/12 to 20/12	7.5	2.29
21/12 to 21/12	8.0	2.44

HORIZONTAL VENT TERMINATION REQUIREMENTS

The venting terminals should not be recessed into a wall or siding.

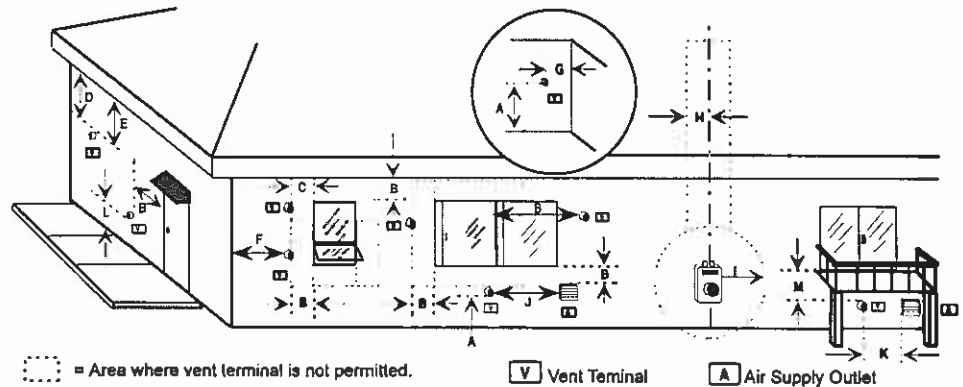

- A = 2" Clearances above grade, veranda, porch, deck or balcony.
- B = 12" Clearance to window or door that may be opened.
- C = 9" (USA) Clearance to permanently closed window. 12" (CAN)
- D = 24" Vertical clearance to ventilated soffit located above the terminal within a horizontal distance of 2 feet (60 cm) from the center-line of the terminal.
- E = 12" Clearance to unventilated soffit.
- F = 9" Clearance to outside corner.
- G = 6" Clearance to inside corner.
- H = 3 ft. (USA) Not to be installed above a meter/regulator assembly within 3 feet (90 cm) horizontally from the centerline of the regulator.
- I = 3 ft. (USA) Clearance to service regulator vent outlet. 6 ft. (CAN)

- J = 9" (USA) Clearance to non-mechanical air supply inlet to building or the combustion air inlet to 12" (CAN) any other appliance.
 - K = 3 ft. (USA) Clearance to a mechanical air supply inlet. 6 ft. (CAN)
 - L* = 7 ft. (USA) Clearance above paved sidewalk or a paved driveway located on public property.
 - M** = 12" Clearance under veranda, porch, deck or balcony
- * A vent shall not terminate directly above a sidewalk or paved driveway, which is located between two single-family dwellings and serves both dwellings.
- ** Only permitted if veranda, porch, deck or balcony is fully open on a minimum of 2 sides beneath the floor.
- Note: Local Codes or Regulations may require different clearances.

INSTALLATION

GAS SUPPLY HOOKUP

If using pipe other than black iron pipe see NFPA 54-National Fire Protection Association / ANSI Z223.1-American National Standards Institute; and local code for specific requirements for the type of pipe used. Alternative gas piping systems such as CSST may be used subject to local code and proper sizing.

⚠ CAUTION

To avoid pipe compounds from entering system, apply compounds only to male pipe threads. Do not apply compound to the first two threads.

A gas supply line must be run to the appliance by a qualified professional. The plumbing of the gas line must comply with National Standards; NFPA 54-National Fire Protection Association / ANSI Z223.1-American National Standards Institute; and local code.

This appliance is equipped with a flexible gas line and fitting for a gas supply line connection. Connection can be made using either the 3/8" NPT male fitting or, by removing the fitting, to the flex line 3/8" female flare. The flex line is located on the bottom of stove. Some areas may have certain restrictions against the use of flexible gas lines. Check local codes. The gas appliance control valve has a 3/8" NPT female type inlet for the gas supply line, if hard plumbing is required.

If the gas supply will be routed to the appliance from the rear or through the floor, the flexible gas line for hookup is readily accessible

Gas piping must not run in or through air ducts, clothes chutes, chimneys or gas vents, dumb waiters or elevator shafts.

Piping should be sloped 1/4" per 15 feet (6mm per 4.6m) upward toward the meter from the appliance. The piping must be supported at proper intervals every 8 to 10 ft. (2.4m to 3.1m) using suitable hangers or straps.

The gas supply line must be purged of air before it is connected to the appliance (See *Air Purging Procedure* on page 13).

An accessible, approved shut-off valve must be installed upstream of any connector so that the appliance may be isolated to allow service, removal, and replacement (within six feet of the appliance per NFPA 54, or twelve inches in some codes). A shut-off valve is provided with this appliance.

IMPORTANT: In case emergency shut-off is required, shut off main manual gas valve and disconnect main power to appliance. These devices should be properly labeled by the installer.

PRESSURE TESTING:

- The appliance main gas valve must be disconnected from the gas supply piping system during any pressure testing of that system at test pressures in excess of *1/2 psi (3.5 kPa).
- The appliance must be isolated from the gas supply piping system by closing its individual manual shut-off valve during any pressure testing of the gas supply piping system at test pressures equal to or less than *1/2 psi (3.5 kPa).

Make the connection to the gas supply line using the correct fitting required to the shut-off valve.

Install a drip leg where condensates might accumulate. Sediment traps, like drips and collection tees, are required to be installed. Traps collect moisture and intercept and hold foreign objects which might block orifices and valves. A drip leg should be installed in vertical pipe runs to the appliance.

* Note: 1/2 psi = 14" WC (inches water column).

INSTALLATION

Supply Line Size Requirements

The proper gas line diameter must be used to run from the supply regulator (at the gas company meter) to the appliance. Never use galvanized or plastic pipe. Refer to the table below for suggested sizing of the gas supply line.

**Suggested Sizing of
Schedule 40 - Pipe Supply Line**

Schedule 40 Pipe Length (Feet)	Schedule 40 Pipe Inside Diameter (Inches)	
	Natural Gas	LP. Gas
0-10	1/2	3/8
10-40	1/2	1/2
40-100	1/2	1/2
100-150	3/4	1/2
150-200	3/4	1/2

Use an approved pipe sealant compound for NPT fittings. After all pipe connections are made, apply normal gas line pressure: 7.0" W.C. for natural gas; 11.0" W.C. for LP gas (propane) and use an approved leak detection solution to test for the tightness of each pipe connection joint.

! IMPORTANT

Compounds used on threaded joints of gas piping must be resistant to the actions of liquified petroleum gases.

IMPORTANT: All connections must be checked for leaks with a leak detector or soapy water solution. Never check for gas leakage with an open flame!

! CAUTION

Some soaps used for leak detection are corrosive to certain metals. Carefully rinse piping thoroughly after leak test has been completed. Do not use matches, candles, flame or other sources of ignition to check for gas leaks.

AIR PURGING PROCEDURES:

Purging Air from Supply Line

- Turn gas supply line valve off.
- Loosen setscrew at inlet pressure tap on upper right of control valve (see *Pressure Taps* on page 4).
- Turn gas supply line valve on.
- When gas flows, turn supply valve off.
- Close the inlet pressure tap.

Purging Air from Appliance

Purge air from appliance by holding gas control valve down in the pilot position until pilot will light (see Fig. below).

DO NOT LIGHT A MATCH IF YOU SMELL GAS.

Light a match then allow gas flow to pilot. If the Match "blows", there is air in the line (purge line). If the flame is straight and tall, there is no gas pressure.

Pilot Assembly

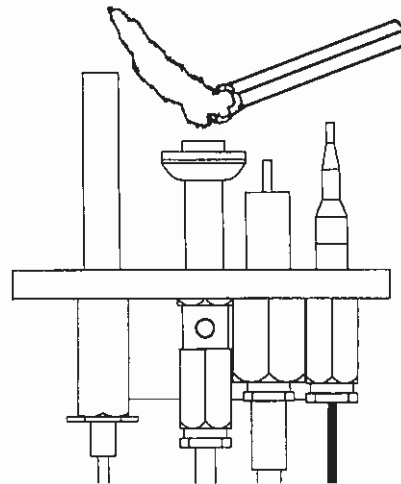

* Note: 1/2 psi = 14" WC (inches water column).

INSTALLATION

Before beginning the assembly / installation process, the following preparations should be completed:

- Ensure that all the components are present (see Packaging List on page 3).
- Run gas supply line to the location of planned installation (see Gas Supply Hook-up, page 12).
- If an optional remote control kit or wall thermostat is to be used, route wires to location of planned installation. For more information on the following kits, see page 30: *Note: The 2 white wires from the burner tray assembly will only be used if an optional remote control kit is installed.*

RC-STAT, CAT NO. 98K99, Deluxe Remote Control RC, CAT NO. 26N04, Standard Remote Control WTK, CAT NO. 89L36, Wall Thermostat Kit

- Venting system components that will be required will vary depending on the venting configuration planned for and the height to the planned termination point (see pages 7 - 10). For venting component ordering information see pages 10 and 11.
- Plan for electrical outlet access (wall receptacle), if the optional *Air Circulation Blower kit* is to be installed.

BK, CAT NO. 14M86, Blower kit

Note: When installed, the power cord will reach approximately 8 feet from the lower back of the stove.

- If installation is higher than 2500 feet above sea level for USA or 4500 feet above seal level in Canada, a high altitude orifice kit is required.

HAOK-TG30, 14M87 - High Altitude Orifice Kit

- If the appliance is factory equipped for use with natural gas and propane (LP) gas is to be used, a natural gas to propane conversion kit is required.

GCKT3NL, CAT NO. 14M15, NG to LP Conversion Kit

- If the appliance is factory equipped for use with propane (LP) and natural gas is to be used, a propane to natural gas conversion kit is required.

GCKT3LN, CAT NO. 14M14, LP to NG Conversion Kit

Note: See page 30 for additional information on ordering Optional Kits.

1. Remove Stove from Pallet

- a. Remove the screws which secure stove legs to pallet using a 5/16" socket.
- b. Gently lift the stove up and off the pallet.
Note: Lifting the stove off the pallet requires a minimum of two people (each standing on opposite sides of the stove).

2. (Applicable only if an optional Remote Control Kit is to be used) Remote Control Sensor Mounting Bracket Installation

The remote control sensor mounting bracket (provided with stove) must be installed on the stove back if an optional remote control kit is to be used.

Caution: Due to high levels of heat directly beneath the firebox, the remote control sensor must not be installed under the stove body.

- a. Locate the hex head screw that secures a small access cover on the lower right corner of rear stove panel.
- b. Remove the hex screw using a ¼" nut driver or socket.
- c. Position the bracket as shown in the picture below and reinstall the screw.
- d. Install and operate the remote control per the instructions provided with the kit. See page 23 of this manual showing the proper wire configuration when the optional remote control kit is installed.

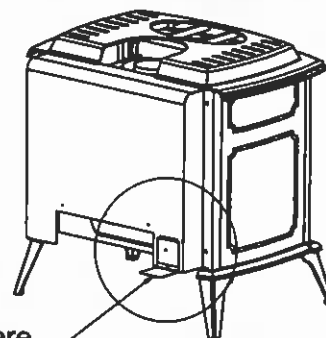

Attach bracket here.

3. Install stove and venting system per instructions on pages 6 to 11.

4. Open the glass door assembly (see *Opening and Closing Door*, page 18).

5. Check (and adjust if necessary) the burner air shutter gap on burner tube (see *Check / Adjust Burner Air Shutter Gap*, page 17).

INSTALLATION

6. Installing Log Set:

After this appliance has been properly installed and all the gas connections have been made and tested, you can now install the log set. See *Door Operation* on page 18 for door removal instructions.

WARNING: If logs are not installed according to the directions in this manual, flame impingement and improper combustion could occur and result in excessive production of soot and carbon monoxide (CO), a colorless, odorless, toxic gas.

This appliance is equipped with a four-piece log set. Carefully install the logs into the firebox as shown on this page. All logs should fit down onto pins and mounts provided. This will ensure a proper flame and safe combustion.

- a. Carefully place the largest log in the rear of the firebox as shown in the following illustration.

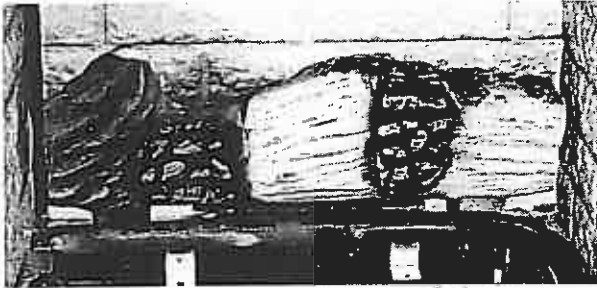

- b. Install the front log as shown in the following illustration.

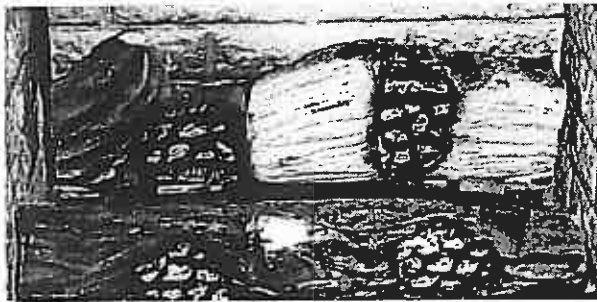

- c. Install the right top twig as shown in the following illustration.



- d. Install the left top twig as shown in the following illustration (see *Glowing Embers* on this page for instructions on proper ember placement on the front burner tube).

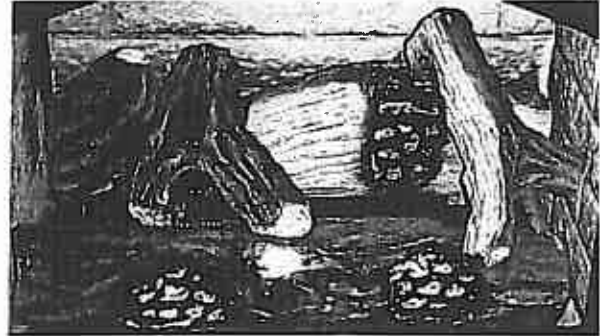

Top View
Log Placement Diagram

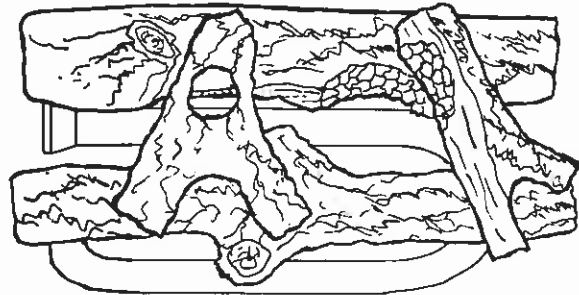

7. Installing Glowing Embers

One package of ember material has been included with this gas appliance. You will not need to use the entire bag (additional ember material is provided for your future maintenance needs).

IMPORTANT: The quantity and placement of the ember material can affect stove performance therefore it is very important that it be placed as shown in the picture below.

Proper Placement of Ember Material: Unpackage and divide the fine ember material (mineral wool) into thumb-nail sized fluffy pieces. Distribute the pieces so it just covers the top of the front burner tube ports.

Place Ember Across Front Burner Tube

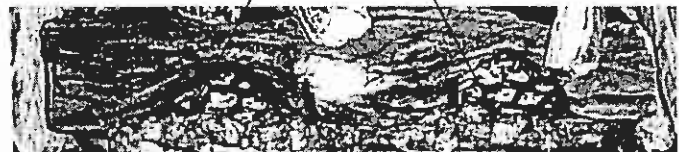

INSTALLATION

INSTALLATION CHECK LIST

Read and understand these instructions before using appliance. Go through this installation checklist:

- Ensure that the log set is properly installed. Use caution when handling the logs. See page 16.
- Reinstall the door assembly. See *Door Assembly* on page 18.

WARNING: Do not operate appliance with the glass door assembly removed, cracked or broken. Replacement of the glass should be done by a qualified technician.

- Ensure venting termination cap is unobstructed.
- Check to see that wiring is correct and is contained to area below the burner tray plate (Ref. Wiring Diagram, page 23).
- Ensure that the relief door under the cast stove top is properly closed (see *Combustion Chamber Relief Door* on page 20).
- Verify that the gas line has been purged of air.
- Test all connections for leaks (factory and field) with a leak detector or soapy water solution. If you smell gas, do not attempt to light this appliance. Follow safety instructions on the front cover of this manual.
- Check / Adjust Burner Air Shutter Gap:

Natural Gas – ¼" gap Propane – ½" gap

Some adjustment from standard may be necessary for the desired flame characteristics (see *Burner Flame Appearance*, page 22).

To adjust air shutter:

Adjust Air Shutter. The standard burner air shutter opening for natural gas is a ¼", and for propane is a ½" (see picture below). Check the air shutter gap and adjust if necessary as outlined in this section (see *Air Shutter Adjustment Guidelines* on this page).

To Adjust: Locate the phillips head setscrew positioned on the top of burner tube where burner orifice is located (see picture below). Use a phillips screwdriver to loosen the screw just enough so shutter can be rotated. Adjust gap as necessary and retighten setscrew.

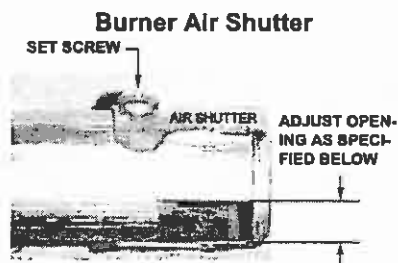

Natural Gas: ¼" gap
Propane: ½" gap

Air Shutter Adjustment Guidelines:

If the burner flame appearance differs greatly from what is shown on page 22 (see *Burner Flame Appearance*), some adjustment from standard for the air shutter gap may be necessary (to compensate for variables in the installation and fuel such as, BTU value / composition, gas pressure, specific gravity of gas, altitude, etc.).

See "Burner Flame Appearance" on page 22 for guidelines on how to determine what is an acceptable burner flame appearance. The following chart is provided to aid you in achieving the correct air shutter adjustment for your installation.

Flame Appearance Chart

Amount of Primary Air	Flame Color	Air Shutter Adjustment
LOW →	More yellow than blue →	Increase gap
HIGH →	More blue than yellow →	Decrease gap

- Light the appliance following the instructions on page 19 (*Care and Operation*). Relight the main burner in both the HI, and LO positions, and verify proper burner ignition and operation.

NOTE: Upon the initial firing of your new gas stove, you may notice an odor. This may last up to two hours. It is recommended to open the windows to allow fresh air to circulate into the room.

WARNING: If the pilot does not light after 1 minute, wait at least 5 minutes for gas to clear before attempting again.

- With burner lit, check to make sure that the inlet gas and manifold pressures are correct (see *Gas Pressure*, page 4). Verify that the pilot and main burner ignition and operation are correct.
- If the optional air circulation blower kit is installed, plug the blower power cord into an 120 V, 60Hz, grounded outlet (see *Air Circulation Blower*, Page 4).

CARE AND OPERATION

DOOR OPERATION

The glass door is mounted on hinges at the right side of the stove firebox and is secured in the closed position by a latch assembly.

Opening and Closing Door

Caution: Never operate the appliance with the door open or unlatched.

The door can be opened and closed by using the Allen head coil handle (provided). To open, insert the allen head portion of handle into door latch assembly (see below) and rotate $\frac{1}{4}$ turn (90° clockwise). The door should now swing open. To close the door, reverse this process.

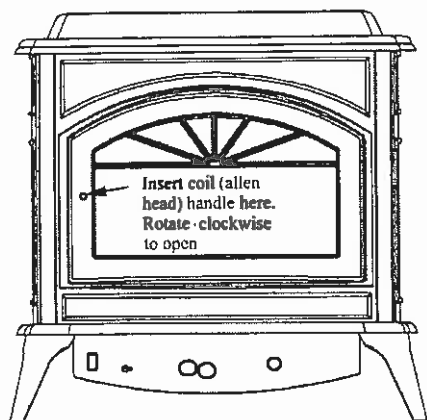

Door Removal - The glass door can be easily removed (if necessary for replacement or maintenance) as follows:

Do not attempt to remove or replace broken glass in the door assembly. Contact your Lennox dealer for glass replacement.

With the door unlatched, swing open to a 90-degree angle from face of stove. Hold the door securely and lift it up and off the hinge pins. To reinstall door, reverse this process.

After setup of the logs and embers is complete, the glass door must be secured closed.

CARE AND OPERATION

FOR YOUR SAFETY READ BEFORE LIGHTING

WARNING: If you do not follow these instructions exactly, a fire or explosion may result causing property damage, personal injury or loss of life.

- A. This appliance has a pilot which must be lit. When lighting the pilot, follow these instructions exactly.
- B. BEFORE LIGHTING smell all around the appliance area for gas. Be sure to smell next to the floor because some gas is heavier than air and will settle on the floor.
WHAT TO DO IF YOU SMELL GAS:
 - Do not try to light any appliance.
 - Do not touch any electric switch; do not use any phone in your building.
 - Immediately call your gas supplier from a neighbor's phone. Follow the gas supplier's instructions.
 - If you cannot reach your gas supplier, call the fire department.
- C. Use only your hand to push in or turn the gas control knob. Never use tools. If the knob will not push in or turn by hand, don't try to repair it, call a qualified service technician. Force or attempted repair may result in a fire or explosion.
- D. Do not use this appliance if any part has been under water. Immediately call a qualified service technician to inspect the appliance and to replace any part of the control system and any gas control which has been under water.

Gas / Burner Controls
(Located below glass door assembly)

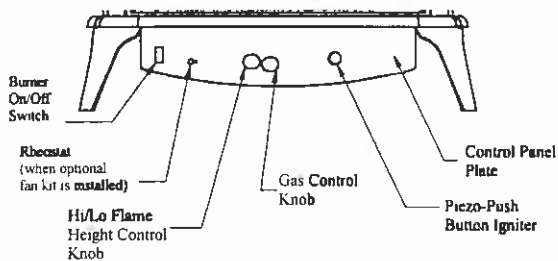

Pilot Assembly

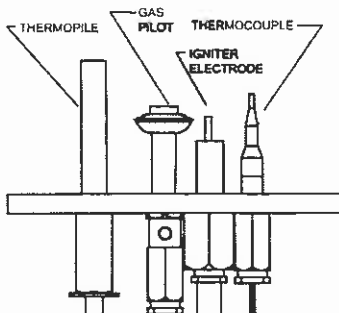

LIGHTING AND SHUTDOWN INSTRUCTIONS

1. STOP! Read the safety information on this page or on label (on appliance).
2. Turn off all electrical power to the appliance (if optional blower is installed unplug blower power cord). Make sure the burner ON/OFF switch is in the OFF position.
3. Locate the gas / burner controls (below the glass door assembly).
4. Push in gas control knob slightly and turn clockwise ↻ to "OFF."
NOTE: Knob cannot be turned from "PILOT" to "OFF" unless knob is pushed in slightly. Do not force.
5. Wait five (5) minutes to clear out any gas. Then smell for gas, including near the floor. If you smell gas, STOP! Follow "B" in the safety information above on this label. If you don't smell gas, go to the next step.
6. Visually locate the pilot located in the center of the firebox beneath the rear ceramic log.
7. Turn knob on gas control counterclockwise ↻ to "PILOT."
8. This appliance contains a spark ignition system (piezo igniter), which is used to light the pilot. Push in the gas control knob all the way and hold it in. Immediately press the button on the piezo igniter located to the right of the gas control knob. The spark produced by the piezo igniter should light the pilot. Continue to hold the control knob in for about one (1) minute after the pilot is lit. Release the gas control knob and it will pop back out. The pilot should remain lit.
 - If it goes out, repeat steps 4 through 8.
 - If the knob does not pop up when released, stop and immediately call your service technician or gas supplier.
 - If the pilot will not stay lit after 3 or 4 tries, turn the gas control knob to "OFF" and call your service technician or gas supplier.
9. Turn gas control counterclockwise ↻ to "ON." Use rocker switch, located either on the control panel or the exterior side panel, to operate main burner. Adjust variable pressure dial (RB Regulator / Flame Height Control) to set burner flame to desired heat output.
10. Turn on electrical power to the appliance (if optional blower is installed, plug in power cord).

TO TURN OFF GAS TO THE APPLIANCE

1. Turn off all electric power to the appliance if service is to be performed.
2. Locate the gas / burner controls (below the glass door assembly).
3. Push in gas control knob slightly and turn clockwise ↻ to "OFF."
NOTES:
 - Knob cannot be turned from "PILOT" to "OFF" unless knob is pushed in slightly. Do not force.
 - The Pilot will have to be relit when resumed use of the appliance is desired (see *Lighting Instructions* on this page).

CARE AND OPERATION

"BREAK-IN" PERIOD

There will be some odor during the first few burns from the curing of the stove paint. Depending on your use, this may take a few hours or a few days. The dwelling should be well ventilated during these initial burns.

KEEP YOUR HOUSE WELL VENTILATED DURING THE CURING PROCESS. THE ODOR AND HAZE EMITTED BY THE CURING PROCESS CAN BE QUITE NOTICEABLE AND MAY SET OFF A SMOKE DETECTOR.

If the optional *Blower Kit* (see page 30 for ordering information) is installed, do not turn on a blower during the break-in period. Do not place anything on the stove surface until the paint is completely cured.

(Model TG300DV, Metallic Black) Do not attempt to repaint the stove until the paint is completely cured. If the surface later becomes stained or marred, it may be lightly sanded and touched up with spray paint (See *Small Area Paint Touch-Up*, page 20). Paint is available at your local authorized Lennox Hearth Products dealer. Never attempt to paint a hot stove.

COMBUSTION CHAMBER PRESSURE RELIEF DOOR

This appliance is equipped with a relief door (located under the stove top) in case of delayed ignition blow back. If the relief door opens, inspect for gasket damage. If necessary, replace with factory supplied gasket only. Confirm that the relief door is closed and properly seated.

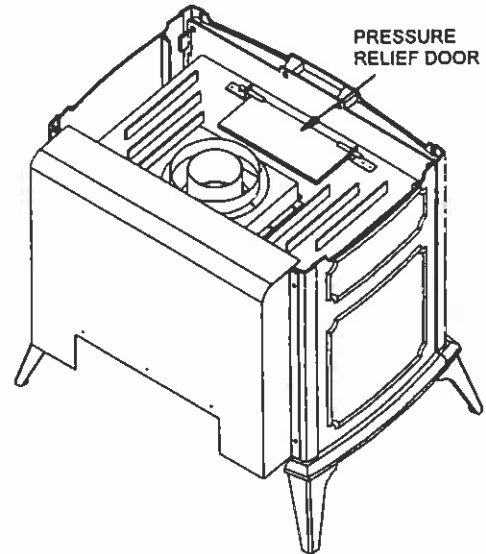

MAINTENANCE

Always Turn Off Gas Control Valve Before Cleaning. Annual Maintenance Should Only Be Performed By A Qualified Service Technician:

LOG SET

Removing & Cleaning Logs - Carefully remove the logs (removing top logs, then lifting front log out, then rear log. See log instructions on page 16). Use care when handling the fiber logs, as they become quite fragile after curing. Use a small soft-bristled brush (e.g., a nylon paint brush) to remove soot, dust or debris that may have accumulated on the burner or log set. See page 16, *Installing Log Set* for instructions on reinstalling logs and glowing embers.

Suggestion - Remove the logs and burner tube, and clean them outside the home in a location with plenty of fresh air ventilation. Avoid breathing fine particulates of dust that may be generated.

Replacing Logs - If logs become damaged by accident or improper handling and need replacement, use only replacement logs provided from manufacturer, which can be purchased from your local dealer. See page 27.

CLEANING BURNER

With the logs removed, vacuum out any foreign matter (lint, carbon etc.) on the burner tube. Be sure the burner ports are "open." Inspect and clean air shutter opening to ensure that it is free from lint, dust, spider webs or any debris (see burner air shutter illustration, page 17).

CLEANING VALVE

Clean all lint and dust build-up around the control valve. Inspect and clean with a brush for any spider webs or lint accumulation.

INSPECT WIRING / CAUTIONS:

- 1) Label all wires prior to disconnection when servicing controls. Wiring errors can cause improper and dangerous operation.
- 2) Verify proper operation after servicing.
- 3) Inspect and clean all wire connections. Ensure that there is no melting or damage. Inspection should include:
 - Terminals at the valve
 - On / Off switch
 - Wall Thermostat / Remote Control (optional kits)

VENTING SYSTEM

A periodic examination of the venting system must be performed to ensure that the flow of combustion and ventilation air is not obstructed (outlet and inlet is open and free from blockage). We recommend that you have your gas appliance checked yearly by your independent Lennox dealer.

If the vent-air intake system is disassembled for any reason, the service technician should follow vent manufactures instructions for proper reassembly and sealing of the vent-air intake system.

IMPORTANT - APPLIANCES INSTALLED USING SIMPSON DURA-VENT BRAND PIPE MUST SEAL ALL JOINTS WITH MILL-PAC BLACK, HIGH TEMPERATURE SEALANT.

CLEAN EXTERNAL SURFACES

External surfaces should be kept clean and dust removed from air inlets to the appliance. The flow of combustion and ventilation air must not be obstructed. The appliance must be kept clear and free from combustible materials, gasoline and other flammable vapors and liquids.

SMALL AREA PAINT TOUCH-UP

(Model TG300DV, Metallic Black only)

The stove body is painted with a quality high-temperature stove paint. Use only model TSPK-B Stove Paint, Catalog # 70K99. Do not touch-up this appliance with any other paint.

Using one small piece of 320 grit sand paper and lightly sand the blemish so that the edges are "feathered" or smooth to the touch between the painted and bare surfaces. Do not let the sand paper gum up with paint, as this will cause scratches on the metal surface. If there are any scratches, use 600 grit sandpaper instead. Mask off surfaces you do not want painted. Paint lightly over the bare surface first as this will act as an undercoat. Then paint over a larger area in smooth even strokes to blend.

See *Break-In Period* on page 20 for information on curing the paint.

CLEANING GLASS

The window on the gas appliance is made from a clear ceramic material and may be cleaned when cool with any non-abrasive product designed for use on glass windows. **Do not use abrasive cleaners on glass.** The viewing glass should be cleaned periodically. Exterior glass may be cleaned with an ammonia-based glass cleaner as desired. Interior glass - use soap and water, or commercial glass cleaner recommended for stove glass.

Note: Each time the appliance is lit, it may cause condensation and fog on the glass. This condensation and fog will disappear in a few minutes.

CLEANING BLOWER INTAKE

(If Optional Blower Kit Is Installed)

The blower air intakes require cleaning at least once a year to remove lint, dust, etc. If there are pets in the dwelling, the intake should be cleaned at least twice a year.

MAINTENANCE

Always Turn Off Gas Control Valve Before Cleaning. Annual Maintenance Should Only Be Performed By A Qualified Service Technician:

PERIODIC CHECK OF PILOT AND BURNER FLAMES

Check the operation of the pilot and cycle the burner. Visually check the flame of the burner making sure the flames are steady; not lifting or floating. The flame color should be blue at the burner with yellow body and tops.

Cycle unit a minimum of 2 times

- Watch for smooth burner ignition and shut down.
- Burner: Check flame patterns. Ensure that burner flame appearance does not vary greatly from diagram shown on this page.
- Pilot: Ensure pilot flame appearance does not vary greatly from diagram shown below.

PILOT FLAME APPEARANCE

A proper pilot flame should consist of torch-like flame issuing from the pilot hood as shown in illustration below.

Proper Pilot Appearance

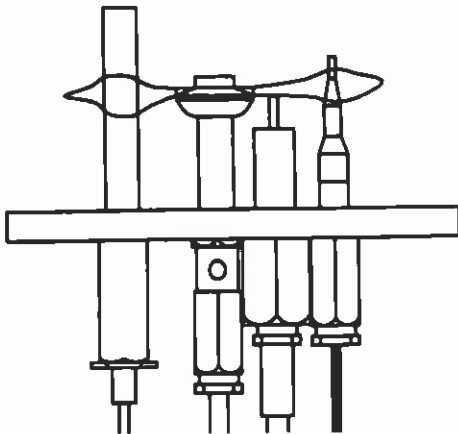

BURNER FLAME APPEARANCE

A periodic visual check of the pilot and burner flames should be performed. If either the pilot or burner flame do not show proper appearance or behavior, as outlined here, consult a qualified gas appliance technician.

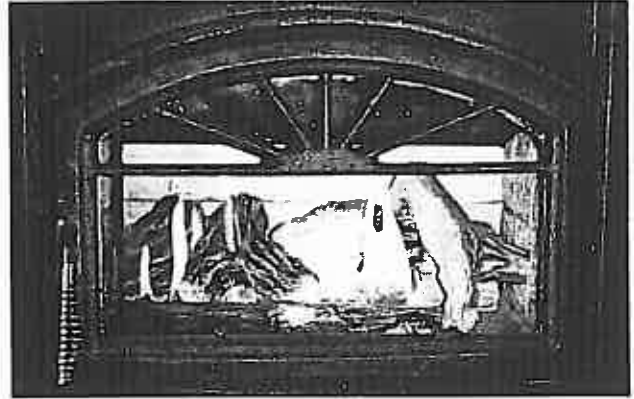

A proper burner flame is shown above. The burner flame should have the following characteristics after initial start-up (let appliance burn 15 to 20 minutes prior to accessing flame appearance):

- Excessive impingement (contact of flame with logs) should not occur.
- Rear burner flames should have yellowish tips; no soot should form at burner flame tips.
- Flames should not raise off of burner (no "lifting" of flame).

The burner flame can be adjusted to give the proper flame appearance and to prevent sooting on the window or logs by adjusting the position of the primary air shutter (see *Air Shutter Adjustment*, on page 17).

NOTE: During periods of high natural gas demand, the gas supplier may add "make-up gases" to the pipeline. This addition will change the composition of the supply gas, and may cause a change in burner flame appearance. You may also notice soot formation on the logs and viewing windows. Check with your gas supplier if you suspect a change in the composition of your gas supply.

MAINTENANCE

BURNER TRAY ASSEMBLY REMOVAL INSTRUCTIONS

If it should ever be necessary to remove the Burner Tray Assembly for maintenance or replacement follow the procedure below.

1. **Disconnect Wires** - Disconnect the wires from the burner tray assembly to the connections on the inside of the control panel as follows (reference wiring diagram on page 23):
 - On / Off Switch – Disconnect the 2 red wires from the burner tray assembly to the 2 connectors on the back of the on/off switch.
 - Igniter – Disconnect the black wire from the burner tray assembly to the connector on the push button piezo igniter.
 - If an optional remote control kit is installed, disconnect the 2 white wires from the burner tray assembly.
2. **Open glass door assembly** (see *Opening and Closing Door* on page 17).
3. **Remove 8 nuts** - Using a 3/8" nut driver or socket remove the eight - (8) nuts around the outer edge of the burner tray assembly.

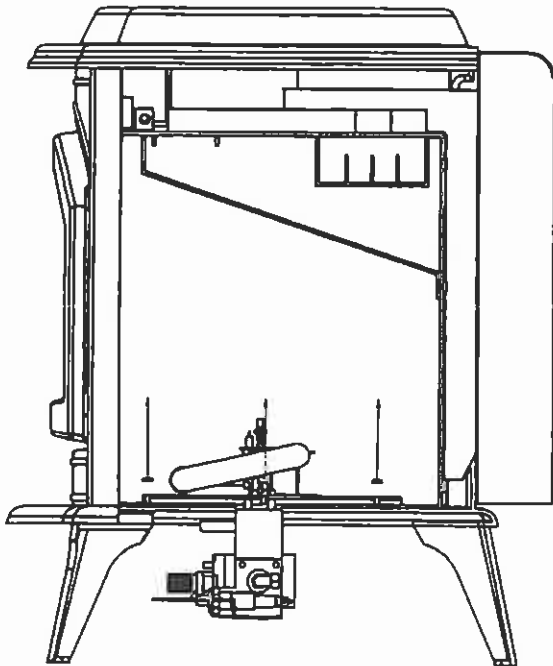

4. **Remove Burner Tray Assembly** - Grasp the burner tube in the center and carefully lift the assembly forward and out of the firebox (see the following 3 illustrations).

Grasp the center of the burner tube, then tilt burner tray assembly forward.

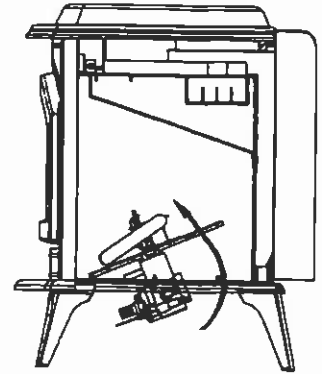

Lift burner tray assembly up and off the studs

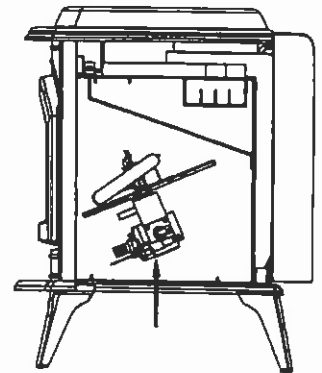

Remove burner tray assembly through the door opening.

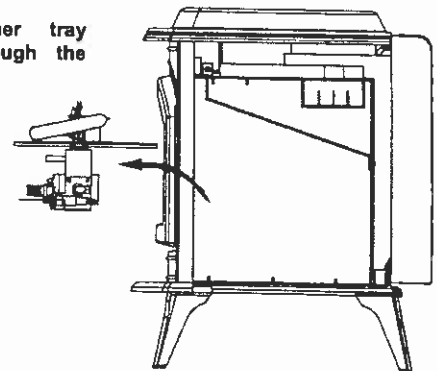

To reinstall the burner tray assembly, reverse steps 1 through 4.

MAINTENANCE

Note: Aligning Control Panel Plate with valve controls (if necessary) - Check alignment of valve knobs with holes in control panel plate and adjust follows (see illustration below):

Valve knob adjustment: Using a 5/16" socket or nut-driver, loosen the 3 screws that secure the control panel plate under the front face of appliance. Adjust plate alignment so valve knobs align with holes in control panel plate then retighten screws.

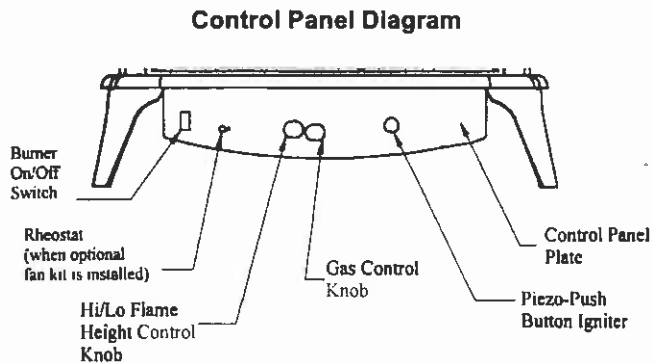

MAINTENANCE

GAS CONTROL AND SAFETY SYSTEM WIRING DIAGRAM

CAUTION: Label all wiring prior to disconnection when servicing controls. Wiring errors can cause improper and dangerous operation. Verify proper operation after servicing.

The gas control wiring diagram shown here should be used by service technicians for guidance when troubleshooting problems with the pilot safety (millivolt) system or burner remote control system or when locating system components for repair / replacement. Note: If replacement of any of the original wire is necessary, use 105°C thermoplastic wiring.

GAS CONTROL AND SAFETY SYSTEM WIRING DIAGRAM

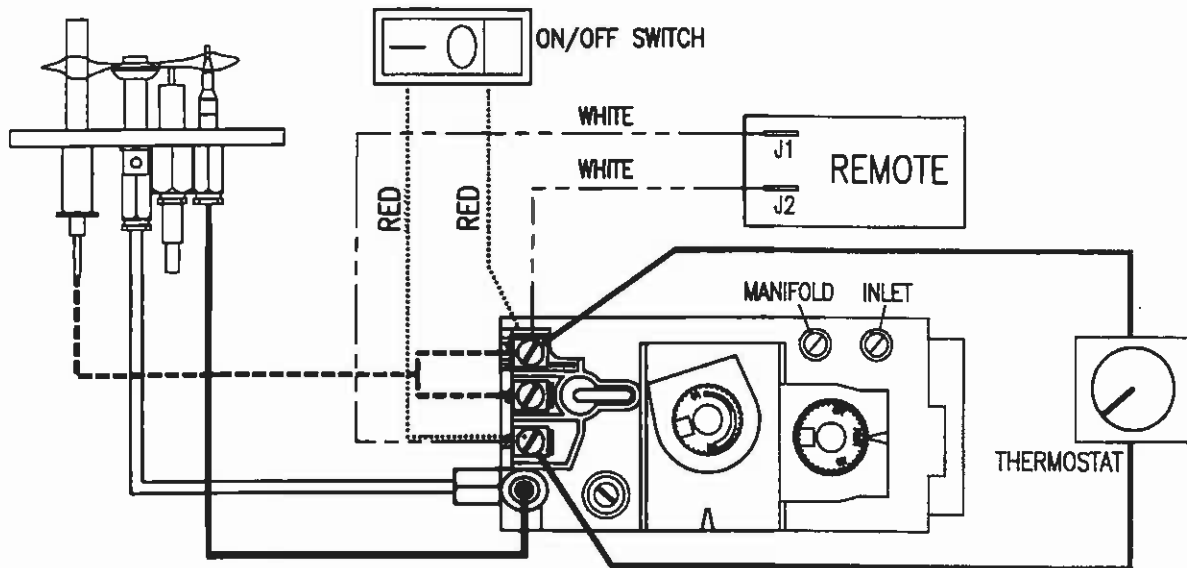

TROUBLESHOOTING *Qualified Technicians Only*

PROBLEM	CAUSE(S)	SOLUTIONS
1) Pilot will not light, and piezo igniter does not produce a heavy blue spark.	<ul style="list-style-type: none"> a. Electrode wire (at piezo igniter) not pushed completely on. b. Piezo igniter is defective 	<ul style="list-style-type: none"> • Make sure connections are solid. • Replace piezo igniter.
2) Pilot will not light, but Piezo Igniter produces a heavy blue spark. Warning: If the pilot will not light after 1 minute of attempting, wait for at least 5 minutes for gas to clear before attempting again.	<ul style="list-style-type: none"> a. Incorrect lighting procedure. b. No gas to appliance due to shut valves or disconnected gas lines. c. Misaligned electrode at pilot. 	<ul style="list-style-type: none"> • Carefully follow the lighting / operating instructions found in the appliance of this owner's manual. • Check for multiple gas shut-offs; check gas supply lines. • Spark should be extending approx. 1/8" to thermopile. Adjust gag to give proper spark. Remove hands from electrode before pressing igniter button.
3) Pilot will not stay lit.	<ul style="list-style-type: none"> a. Thermocouple is not firmly connected to control valve. b. Pilot flame is not directed to top of thermocouple. c. Thermocouple is defective. Make sure connection is solid. 	<ul style="list-style-type: none"> • Ensure thermocouple is fully inserted into pilot assembly. • Replace thermocouple.
4) Pilot drops out when main burner is switched on.	<ul style="list-style-type: none"> a. Main burner switch wired incorrectly. b. Main burner wire shorted or stressed. c. Faulty main burner EMU. d. Improper pilot adjustment. e. ON/OFF switch defective. 	<ul style="list-style-type: none"> • Correct wiring. • Check wire and correct if necessary. • Check valve. * Replace valve or burner tray assembly if necessary. • Check pilot flame. Adjust flame if necessary. • Check ON/OFF switch for proper connections. Connect wires across terminal at ON/OFF switch. If burner comes on, replace ON/OFF switch. If not, jumper junctions at valve. If burner comes on, replace wires.
5) Pilot flame stays lit, but main burner will not light.	<ul style="list-style-type: none"> a. Burner control switch (On / Off) is in "OFF" position; or thermostat (if installed) is turned off or temperature setting is too low. b. Electrical wiring is damaged or poorly connected. c. One of the following components may be defective: burner control switch, thermostat, or thermopile. 	<ul style="list-style-type: none"> • Position the burner control switch to "ON"; or adjust the thermostat. Refer to manufacturer's instructions for thermostat. • Refer to Control and Safety Wiring Diagram (page 23) and check electrical connections. • Refer to Control and Safety Systems Wiring Diagram. Electrically bypass components one at a time and replace defective item.
6) Smell of gas	<ul style="list-style-type: none"> a. Loose fittings may be allowing gas to leak out. 	<ul style="list-style-type: none"> • Check all joints for leakage: pilot assembly, gas supply system, main burner assembly, pilot and burner adjustment screws. Use a proper leak check solution. WARNING: Never use an open flame to check for leaks.
7) A thin coating of black soot forms on the window. NOTE: See page 21, <i>Cleaning Glass</i> .	<ul style="list-style-type: none"> a. Burner primary air inlet is restricted or blocked. b. Flames make contact with logs or other surfaces. c. Improper venting. 	<ul style="list-style-type: none"> • Be sure all openings (fresh air inlets) in stove are free from dust and debris. Recheck these areas periodically. • Make sure logs are in their correct positions. • Check for flue blockage, disconnected flue, improper installation, negative air pressure inside building (with respect to exhaust exit), or "down draft" situation. Make appropriate corrections.

TROUBLESHOOTING *Qualified Technicians Only*

PROBLEM	CAUSE(S)	SOLUTIONS
8) A white coating forms on windows, logs, and / or inside walls of firebox.	a. Residues / impurities being burned off (byproducts from the fuel).	<ul style="list-style-type: none"> Follow cleaning guidelines outlined in the MAINTENANCE section of this manual.
9) Glass fogs up.	a. A normal result of gas combustion.	<ul style="list-style-type: none"> No action necessary. After the heater has warmed up, the glass will clear.
10). Blue flames.	a. A normal result during the first 20 minutes.	<ul style="list-style-type: none"> No action is necessary. Flames will begin to turn more yellowish after about 20 minutes of burning.
11) Sticking valves.	a. Debris and moisture from the gas line clogging valve.	<ul style="list-style-type: none"> Improper plumbing, no drip leg in line to prevent travel of moisture and dirt. * Replace damaged valve and correct plumbing.
12) Flame noise -rumbling/gurgling.	a. Excessive primary air.	<ul style="list-style-type: none"> Adjust burner air shutter.
13) Orifice noise (buzz or whistle).	a. Trash lodged in orifice. b. Burr in main burner orifice.	<ul style="list-style-type: none"> Clean orifice; replace if necessary. Debur or replace orifice.
14) Soot &/or Floating flames. Usually accompanied by the odor of aldehydes. Sooting – First Rule Out: Soot staining and soiling of carpets, drapes, windows & other household components can often be traced to the use of such items as candles, oil lamps, incense, and other misc. aromatic off-gassing materials. <i>If soot is not present in the firebox, it cannot be the source of the external soot.</i>	a. Sooting - Free carbon produced by potentially dangerous improper/incomplete combustion of gas. b. Floating Flames: Lazy, ill-defined, quiet flame, which roll around sometimes completely off the port. Potentially dangerous incomplete combustion.	<ul style="list-style-type: none"> Check appliance input rate (gas pressure: inlet and manifold, & burner orifice size) and reduce if necessary. Insufficient secondary air due to restricted exhaust flow (the rate at which the exhaust leaves determines the rate at which the secondary air is delivered). Horizontal run (requires 1/4" rise per foot horizontal), inner pipe not secured, vent termination interference. Blocked burners/Flame impingement: Correct log & burner positioning. Insufficient primary air (yellow tipping): Adjust primary air. IN ALL CASES: Annual Service Procedure should be performed. Propane Units: LP tanks can suffer pressure decreases, which can result in sooting as it approaches empty. Higher Elevations – See <i>High Altitude</i>, page 4).
15) Burner Flashback Air/gas mixture ignites inside burner near orifice, creating roaring noise (like blowtorch). Production of carbon monoxide & aldehydes possible. Soot may clog inside of burner. Problem: Imbalance of gas flow velocity & burning speed pattern.	a. Excessive primary air. b. Burner input underrated c. Valve leak if flashback occurs w/ burner valve in "OFF" position.	<ul style="list-style-type: none"> Reduce primary air, being careful to avoid yellow tipping. Check input rate. Check input pressure using a manometer. Replace RB regulator or burner tray assembly if necessary. Confirm correct gas pressure at house meter or tank (call gas company). Improper gas pipe size, correct plumbing. Confirm correct size burner orifice. Replace valve or burner tray assembly if necessary. If above correction doesn't correct, replace burner.
16) Flame lifts from burner and pilot.	a. Air Starvation. Poor connection of inner pipe. No rise on horizontal run of pipe.	<ul style="list-style-type: none"> Raise cap so that inner pipe has at least a 1/4" rise per 1 (one) foot of horizontal run. Check pipe connections.

TROUBLESHOOTING *Qualified Technicians Only*

PROBLEM	CAUSE(S)	SOLUTIONS
17) Delayed Ignition (makes a sudden "whoosh" noise as burner lights).	a. This is a buildup of gases prior to ignition. This is more prevalent with propane (LP) fuel, since gas is heavier.	<ul style="list-style-type: none"> • Primary air shutter closed too far. Adjust shutter to correct gap. • Burner ports plugged, not allowing proper flame travel. Open ports. • Pilot is not positioned closed enough to light up row on burner. Adjust pilot location. • Logs placed improperly interfering with flame travel. Correct log positioning.. • Unit not properly derated for higher altitudes. Derate unit. • Excessive gas pressure - Call gas company. • (Propane units). Burner tube is not level, not allowing correct mix of primary air and gas.
18) Flame lifts from burner and pilot.	a. Air Starvation. Poor connection of inner pipe. No rise on horizontal run of pipe.	<ul style="list-style-type: none"> • Raise cap so that inner pipe has at least a 1/4" rise per 1 (one) foot of horizontal run. Check pipe connections.
19) Intermittent lifting and cycling of flame. Possible intermittent pilot dropout problems.	<ul style="list-style-type: none"> a. High wind conditions. b. Cap Obstructed. c. Inner pipe disconnected from elbow. d. Improper clearances from vent to surrounding environment (windows, soffits, etc). This is both an operational & safety concern. e. External Environment-Buildings/ trees/ rooflines interfering w/venting. 	<ul style="list-style-type: none"> • Install high wind cap. • Check for siding or other materials obstructing or overlapping vent cap. Reset cap ensuring that nothing overlaps or obstructs it. • Reconnect inner pipe. If inner pipe is not secured to elbow with three screws, pipe can disconnect and cause venting problems. Remove cap - reach inside and reset pipe to elbow. • Correct installation.
20) Low flame. Possible intermittent pilot dropout problems.	a. The (vent pipe) air restrictor rings left out.	<ul style="list-style-type: none"> • Install restrictor rings.
21) If optional blower kit is installed - Circulation blower makes a humming sound, but there is no circulation air.	<ul style="list-style-type: none"> a. Impeller blades in circulation blower are dirty. b. Circulation blower is defective. 	<ul style="list-style-type: none"> • Disconnect electrical power to circulation blower, access blower and clean impeller blades as outlined in the MAINTENANCE section of this manual. • Replace blower.

Reference information for qualified technician:

Thermopile / Thermocouple Operation

- Thermopile: Millivolt production should be a minimum of 325 mV with pilot only.
- Thermocouple: Millivolt production should be a minimum of 14 mV with pilot only.

Drop out rate

- TP 50-60 mV
- TP 1 1/2-2 Min. (3 max.) if longer, replace thermopile.

REPLACEMENT PARTS Model TG300DV Series

Item No.	Part No. / Cat. No.	Description
		Door Parts
1	28M25	Door Assembly, Cast Metallic Black (Model TG300DV)
1	28M27	Door Assembly, Enamel Ebony Black (Model TG301DV)
1	28M26H	Door Assembly, Enamel Hunter Green (Model TG305DV)
1	28M28	Door Assembly, Enamel Mojave Sand (Model TG308DV)
2	39250	Latch Assembly, Door Bolt (includes torque plate)
3	39010	Allen Head Door Opener
4	T30-G	Glass, Front Door Arched 17" x 10 1/4" (gasket not included)
	27M64	Clip Set, Glass
5	26M18	Hinge Pin Set, Black (includes brackets and hardware)
	10362	Latch, Door (torque plate for latch assembly)
	26M81	Gasket Kit, Door, 3/4" Rope - 8 ft.
	27M27	Gasket, Door Glass- .197" x .875", 5 feet (self adhesive backing)
	T300-6	Trivet, Cast Iron (Black Painted)
		Gas / Electrical Parts
6	10750092	Valve Assembly w/RB Regulator – Natural Gas (NG)
6	10850057	Valve Assembly w/RB Regulator – Propane (LP)
7	30110	Burner Tray Assembly – Natural Gas (NG)
7	30120	Burner Tray Assembly – Propane (LP)
	45059H	Pilot Assembly, Natural Gas (includes pilot tube, igniter electrode, thermopile, thermocouple, & pilot orifice)
	45063	Pilot Assembly, Propane (LP) (includes pilot tube, igniter electrode, thermopile, thermocouple, & pilot orifice)
	26M76	Pilot Tube Kit, 0.199.620, 24", includes fittings
9	18050	Thermopile
10	32041	Thermocouple, 24" with brass threaded retainer (for securing to pilot bracket).
11	410-270	Switch, ON/OFF Burner (Rocker Switch)
	25095	Wire Harness, Valve
15	18081	Piezo Igniter, Push Button
	25068	Igniter Wire, 16"
20	39012	Burner Tube Assembly
	34128	Wire Harness, Valve
	34062	Orifice, Burner (#30) – Natural Gas (NG)
	34047	Orifice, Burner (#49) – Propane (LP)
21	45143	Orifice, Pilot – Natural Gas (NG)
21	45144	Orifice, Pilot – Propane (LP)
		Fan System (Optional Kit)
	14M86	Blower Assembly
	25095	Wire Harness, Blower
12	528	Rheostat, Fan Speed Control (knob not included)
	15049	Disc, Low Limit F140-20F (thermally activated fan disc)
	180	Knob, Rheostat
	26M22	Power Cord Kit, Replacement
		Logs / Brick Panels
17	36016	Log Set, 4 pc. Fiber
18	39015	Brick Panel Set, 4 pc.
	88L53	Glowing Embers
	39032	Log Positioners (order 2 if set is needed)
		Miscellaneous Component Parts
13	39028	Knob, Hi /Lo (flame height control knob)
14	39020	Extension, Pilot knob
	25015	Gasket, Relief Door
	19136	Gasket, Exhaust Collar
	39018	Heat Shield, Rear
16	39008	Panel, Control
19	39035	Bracket, Remote Control Sensor Mounting
	20751075	Leg Leveler, 2 ea. (for 4, order 2 sets)
	775036M	Manual, Installation & Operation
	26021	Paint, 1/2 oz. Green Touch-up for enamel
	26022	Paint, 1/2 oz. Black Touch-up for enamel
	26023	Paint, 1/2 oz. Mojave Sand Touch-up for enamel

REPLACEMENT PARTS Model TG300DV Series

CONTROL PANEL AND CONTROLS

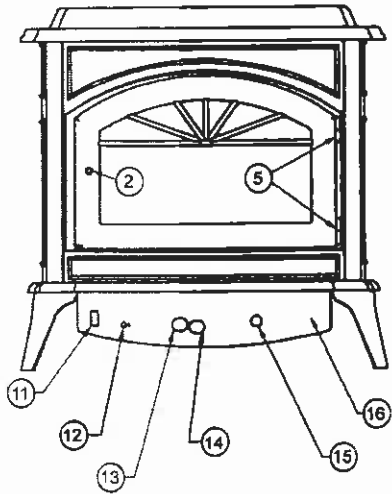

BRICK PANEL SET (18)

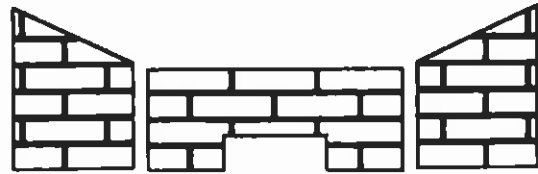

**BURNER TRAY ASSEMBLY (7)
(Side View)**

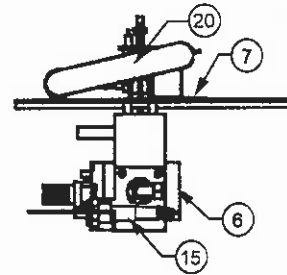

DOOR ASSEMBLY (1)

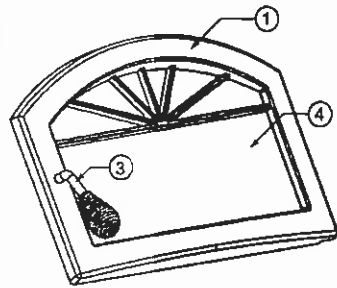

**PILOT ASSEMBLY (8)
(Side View)**

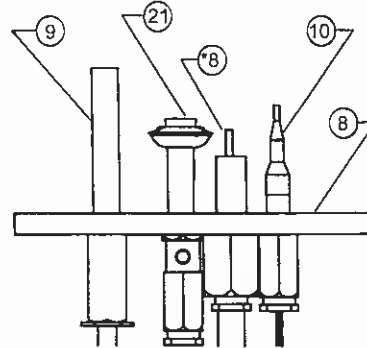

LATCH ASSEMBLY (2) & DOOR OPENER (3)

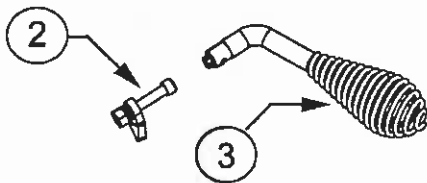

** If the igniter electrode is needed, order pilot assembly, #8*

LOG SET (17)

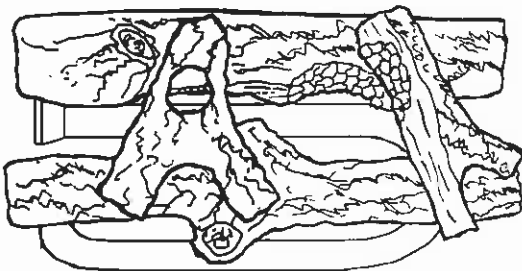

STOVE
BACK

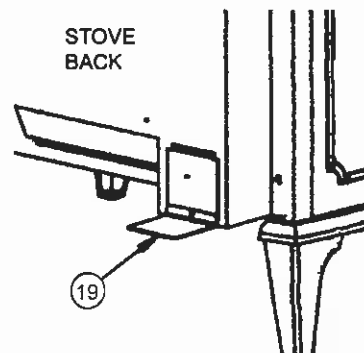

OPTIONAL ACCESSORIES Model TG300DV Series

Item #	Catalog #	Model	Description
1	98K99	RC-STAT	Deluxe Remote Control (thermostatically controlled)
2	26N04	RC	Remote Control (standard on / off)
3	89L36	WTK	Wall Thermostat Kit
4	14M16	TT-G	Gold Plated Trivet
5	14M86	BK-TG30	Blower Kit with Rheostat and Fan Sensor
6	70K99	TSPK-B	Touch-up Spray Paint Kit, Metallic Black
	14M14	GCKT3LN	Conversion Kit, Propane to Natural Gas
	14M15	GCKT3NL	Conversion Kit, Natural Gas to Propane
	14M87	HAOK-TG30	High Altitude Orifice Kit
	85L53H	FGE	Glowing Embers, Bag
	14M17	VP-BH	Vent Paint, Ebony Black - High Gloss
	14M18	VP-GH	Vent Paint, Hunter Green - High Gloss
	14M19	VP-MH	Vent Paint, Mojave Sand - High Gloss

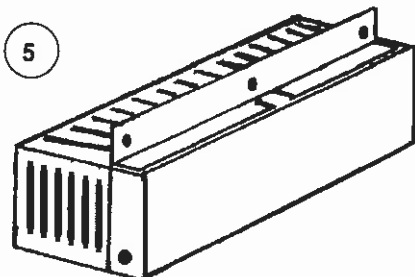
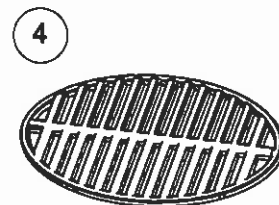
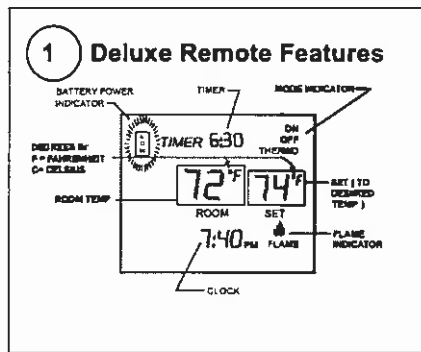
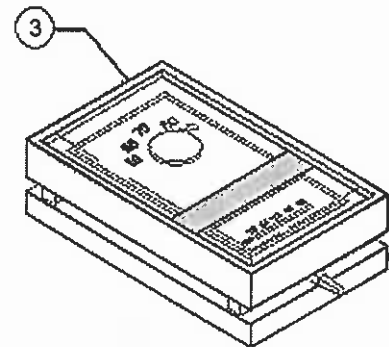
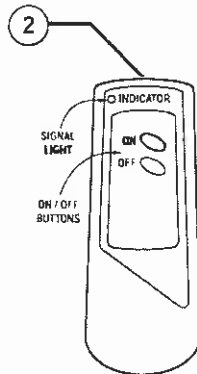
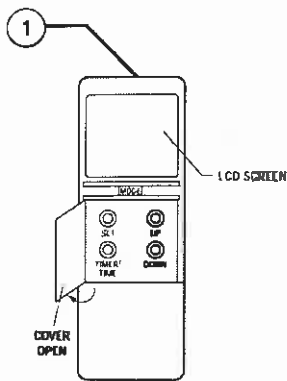

SPECIFICATIONS: Model TG300DV

Heating Capacity ~1500 square feet.

Flue Size 4" – Top Flue Outlet
 Intake Pipe 6.625" (6 5/8")
 Height Overall 28 3/4"
 Height (to flue) 26 3/8"

Width Overall 28 3/4"
 Depth Overall 24"

Fuel Natural or LP Gas.
 Gas inlet 3/8" NPT.

Performance Features Variable Flame Control.
 Full top & back heat exchanger.
 Natural convection & radiant heat.

◆ Safety Test Listed by Warnock Hersey (ITS)
 Z21.11.1-1995 Gas fired vent room heater
 Z21.50/CGA 2.22-M96 Decorative gas appl.
 Z21.44-1995 Gas fir. grav./fan type D.V. wall furn.
 CAN/CGA 2.17-M91 gas fired/high altitude
 CAN1-2.19-M81 gas fired direct-vent wall furnace

Heat Input 23,700-40,000BTU's (Natural Gas)
 30,000-40,000BTU's (Propane)

Ship Weight 363 lb.'s. (Stove Body w/Burner Tray Assembly)

- Square feet heating capacities are approximations only. They will vary depending upon the level of insulation, climate, house design, ceiling height, ambient outside temperatures and how the stove is operated.

Note: Dimensions shown are approximations only (+/- 1/4")

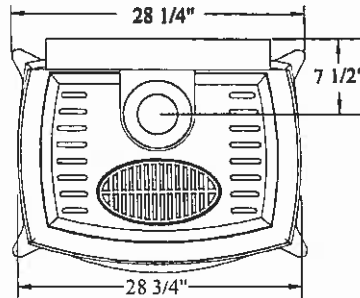
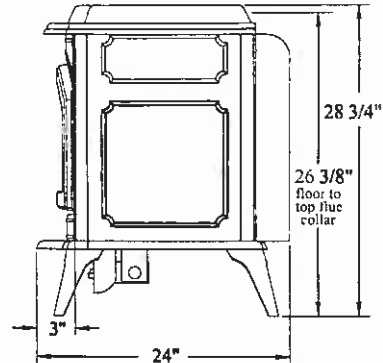
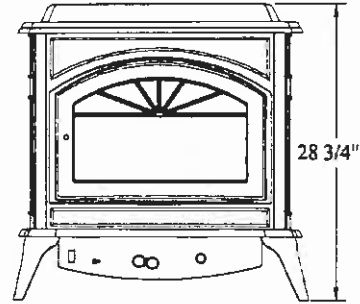

SPECIFICATIONS			
GAS TYPE	NATURAL GAS	PROPANE GAS-LP	MINIMUM CLEARANCES TO COMBUSTIBLES
Orifice Size	#30 -.129"	#49-.073"	Back Wall 5 In. / 127 mm
Min./Max. Supply Pressure	4.5/10.5" WC	10.5/13" WC	Side Wall 5 In. / 127 mm
Output BTU/Hr (efficiency)			Corner (45° angle) stove corner to wall 5 In. / 127 mm
Blower On	32,000 (80%)	32,000 (80%)	Ceiling Minimum 60 In. / 1524 mm
Blower Off	31,600 (79%)	32,000 (80%)	Alcove Min. Height 60 In. / 1524 mm
HIGH SETTING			Alcove Min. width 37 3/4 In. / 959 mm
Manifold Pressure	3.5" WC	10.0" WC	Alcove Max. Depth 48 In. / 1220 mm
Input BTU/HR	40,000	40,000	Max Wall Thickness 31 In. / 788 mm
LOW SETTING			
Manifold Pressure	1.7" WC	6.3" WC	
Input BTU/HR	23,700	30,000	
Altitude - U.S.A. 0-2000 Ft. (0-610M) No derating * Altitude - Canada 0-4500 Ft. (0-1372M) No derating * * With orifice, manifold pressure and input ratings shown above. Altitudes above 2000 FT (610M) for USA and 4500 FT (1372M) for Canada, reorifice per manual and consult local codes.			The efficiency rating of the appliance is a product thermal efficiency rating determined under continuous operating conditions and was determined independently of any installed system.
FUEL - This Appliance is equipped at the factory for the use with Natural Gas or Propane (LP). Units using propane must be either factory LP or field conversion using an Earth Stove® Propane Conversion Kit (Cat. No. 14M15). Units using natural gas must be either factory natural gas or field converted using an Earth Stove® Natural Gas Conversion Kit (Cat. No. 14M14).			

SAFETY / LISTING LABEL

LISTED GAS FIRED DIRECT VENT ROOM HEATER

Tested & Listed by



Model TG300DV

Report No. 478-1527

Certified for use in USA and Canada.

May be installed in Manufactured Mobile Homes.

This stove is factory equipped for:

- Natural Gas
- Propane (LP)

Tested to ANSI Standards, Z21.44-1995 Gas Fired Gravity and Fan type Direct Vent Wall Furnace and applicable sections of Z21.11.1a-1993 Gas Fired Vented Room Heaters, CAN 1-2.19-M81 Gas Fired Direct Vent Wall Furnace, Z21.50-1996/CGA 2.22-M96 Decorative Gas Appliances, CAN/CGA-2.17-M91 Gas Fired Appliances for use at high altitudes, UL307B Gas Burning Heating Appliances for manufactured homes (mobile homes).

For an appliance for manufactured home (mobile home) installation, "This appliance must be installed in accordance with the current Standard Mobile Homes, CAN/CSA Z240 MH, or with the Manufactured Home Construction and Safety Standard, Title 24 CFR, Part 3280, or when such a standard is not applicable, the current Standard for Fire Safety Criteria for Manufactured Home Installations, Sites and Communities, ANSI/NFPA 501A."

SPECIFICATIONS			
GAS TYPE	NATURAL GAS	PROPANE GAS (LP)	MINIMUM CLEARANCES TO COMBUSTIBLES
Orifice Size	#30 - .129"	#49 - .073"	Back Wall
Min./Max. Supply Pressure	4.5/10.5" WC	10.5/13" WC	Side Wall
Output BTU/HR (Efficiency)			Corner (45° angle) corner to wall
Blower On	32,000 (80%)	32,000 (80%)	
Blower Off	31,600 (79%)	32,000 (80%)	
HIGH SETTING			Ceiling Minimum
Manifold Pressure	3.5" WC	10.0" WC	Alcove Min. Height
Input BTU/HR	40,000	40,000	Alcove Min. Width
LOW SETTING			Alcove Max. Depth
Manifold Pressure	1.7" WC	6.3" WC	Max. Wall Thickness
Input BTU/HR	23,700	30,000	
Altitude - U.S.A.	0-2,000 Ft. (0-610 M) No derating *		Elect. Rating - Fan #14M86: 120V, 60Hz, 1.5A
Altitude - CANADA	0-4,500 Ft. (0-1372 M) No derating *		
* With the orifice, manifold pressure and input ratings shown above.			
Altitudes above 2,000 Ft. (610 M) for USA and 4,500 Ft. (1372M) for Canada, reorifice per manual and consult local codes.			
This appliance is equipped at the factory for use with either Natural Gas or Propane (LP). Units using propane must be either factory LP or field converted using The LP Conversion Kit, part number #14M15. Units using natural gas must be either factory natural gas or field converted using The Natural Gas Conversion Kit, part number #14M14.			

Install and use only in accordance with the manufacturer's installation and operating instructions. Keep the burner and control compartment clean. This appliance must be installed in accordance with local codes, if any. If not, follow the current ANSI Z223.1 National Fuel Gas Code in USA, and CGA B149 in Canada. Electrical connections and grounding must be in accordance with local codes, if any. If not, follow the current National Electrical Code ANSI/NFPA 70 In USA, or CSA C22.1 Canadian Electrical Code in Canada.

Only for direct discharge without duct connection. This appliance may be installed in a bedroom.

WARNING: Improper installation, adjustment, alteration, service, or maintenance can cause property damage, personal injury or loss of life. Refer to the owner's information manual provided with this appliance. Installation and service must be performed by a qualified installer, service agency or the gas supplier.

CAUTION: Hot while in operation. Do not touch. Keep children, furniture, gasoline and other liquids with flammable vapors away. Never operate unit with glass door off.

Mfg. by Lennox Hearth Products; 1110 West Taft Avenue; Orange, CA 92865

39029 REV A

DO NOT REMOVE THIS LABEL

MADE IN USA

IGN

LENNOX[®]

HEARTH PRODUCTS

1110 West Taft Avenue

Orange, CA 92865