



User Manual

BCP-500L, BCP-500S, BCP-600L, BCP-600S, BCP-5001L, BCP-5001S

⚠WARNING

Improper installation, adjustment, alteration, service or maintenance can cause bodily injury or property damage. Read the installation, operation and maintenance instructions thoroughly before installing or servicing this equipment.



BCP-500L



BCP-500S



BCP-600L



BCP-600S



BCP-5001L



BCP-5001S

⚠DANGER

Failure to follow these instructions could result in fire or explosion that could cause property damage, personal injury or death.

⚠DANGER

DO NOT use gas grill for indoor cooking or heating. TOXIC fumes can accumulate and cause asphyxiation. DO NOT use in or on boats or recreational vehicles.

⚠WARNING

**FOR YOUR SAFETY!
For Outdoor Use Only
(Outside any enclosure)**



FOR CUSTOMER SERVICE:

CALL 1 -877-885-8227 (TOLL-FREE)

10:00 A.M. – 7:00 P.M.

(EST) MONDAY-FRIDAY

Grill Operation 1-2-3

Before Grilling

- Step 1 Keep your grill a safe distance away from your property.*
- Step 2 Always perform a Leak Test on all connections and hoses. *
- Step 3 Keep children away from the grill.

During Grilling

(To avoid tripping safety valves, please follow these instructions carefully!)

- Step 1 First open lid and turn gas tank on slowly.
- Step 2 Turn only one knob on at a time when lighting up the grill.
- Step 3 Use protective gloves when grill gets hot.
- Step 4 Never leave a lit grill unattended.

After Grilling

- Step 1 Always burn grill for 10-15 minutes to burn off food residues after use.
- Step 2 Wait until the grill is completely cooled before closing lid.
- Step 3 Clean up grease build-up to avoid grease fire and cover your grill to prevent rust.

* Please refer to the owner's manual for details.

WARNING

1. **DO NOT** use or store gasoline or other flammable liquids or vapors in the vicinity of this appliance or any other appliance.
2. An LP cylinder not connected for use shall not be stored in the vicinity of this or any other appliance.

DANGER

IF YOU SMELL GAS

1. **TURN OFF** gas
2. Extinguish any open flame
3. Open the lid
4. If odor continues, keep away from the appliance immediately. Call your gas supplier or your fire department.

Always read and understand the WARNINGS and INSTRUCTIONS that are contained in this manual before attempting to use this gas barbecue grill to prevent possible bodily injury or property damage.

NOTE: This grill must be used with propane gas only (propane gas hose and cylinder not included).

Installer: Leave this manual with the consumer.

Consumer: Retain this manual for future reference.

Table of Contents

For Your Safety.....	4
Safe Locations for Use of This Outdoor Grill.....	5
BBQ FEATURES.....	6
BBQ Specifications.....	10
Grill Parts	10
Installing the Appliance in a BBQ Island.....	11
Building BBQ Specifications.....	12
Installation Method.....	13
Conversion from LP to NG Grill.....	14
Operating Your Grill.....	16
Connecting & Disconnecting Gas Cylinder.....	17
Checking for Leaks.....	17
Lighting Your Grill.....	17
Flame Adjustment.....	18
Excess flow safety valve reset procedure.....	19
Care and Maintenance.....	20
Cleaning Your Appliance.....	20
Troubleshooting.....	21
Warranty Program.....	23
BroilChef Premium Accessories.....	24

For Your Safety

Dear Valued Customer,

Congratulations on your new barbecue grill purchase! You've made the right choice. In this manual, you will find assembly instructions, suggestions for grilling and helpful hints, as well as guidelines for the safe operation, proper care and use of your grill. Our expert staff strives to provide you with an easy-to-assemble product. Should you have any questions or problems with this product, please call our customer service department at 1-877-630-5396 (10:00 am – 7:00 pm (EST), Monday through Friday.).

IMPORTANT NOTICE: READ ALL INSTRUCTIONS PRIOR TO ASSEMBLY AND USE

Safety First!

Read and understand all warnings and precautions prior to operating your grill.

WARNING

1. This grill is for outside use only. It should not be used in a building, garage or any other enclosed area.
2. The use of alcohol, prescription or non-prescription drugs may impair an individual's ability to properly assemble or safely operate this appliance.
3. Always open the grill lid carefully and slowly as heat and steam trapped within the grill could cause severe burns.
4. Always place your grill on a hard and level surface far away from combustible materials and structures. An asphalt or blacktop surface may not be acceptable for this purpose.
5. Do not leave a lit grill unattended.
6. Keep children and pets away from the grill at all times.
7. This is not a tabletop grill. Do not place this grill on any type of tabletop surface.
8. Do not use the grill in high winds.
9. This grill must be used with propane gas only (propane gas cylinder not included).
10. Do not attempt to attach this grill to the self-contained propane system of a camper, trailer, motor home or house.
11. Do not use charcoal or lighter fluid.
12. Do not use gasoline, kerosene or alcohol for lighting. The liquid propane (LP) gas supply cylinder must be constructed and marked in accordance with the specifications for LP gas cylinders of the National Standard of the Transportation of Dangerous Goods Commission of Canada for Cylinders, Spheres and Tubes (CAN/CSA-B139).
13. This outdoor gas appliance is not intended to be installed in or on recreation vehicles and/or boats.
14. Do not attempt to move the grill while it is lit.
15. Do not use the grill unless it is COMPLETELY assembled and all parts are securely fastened and tightened.
16. Keep combustible items and surfaces at least 6 feet away from the grill at all times. DO NOT use this gas grill or any gas product under any overhead enclosure or near any unprotected combustible constructions.
17. Do not use in an explosive atmosphere. Keep grill area clear and free from combustible materials, gasoline and other flammable vapours and liquids.
18. Do not attempt to use or assemble with missing or damaged parts. Contact customer service for replacement parts.
19. Keep any electrical supply cord and the fuel supply hose away from any heated surfaces.

CAUTION - Prevention of Burns

1. To protect against electric shock, do not immerse cord or plugs in water or other liquid;
2. Unplug from the outlet when not in use and before cleaning. Allow to cool before putting on or taking off parts;
3. Do not operate any outdoor cooking gas appliance with a damaged cord, plug, or after the appliance malfunctions or has been damaged in any manner. Contact the manufacturer for repair;
4. Do not let the cord hang over the edge of a table or touch hot surfaces;
5. Do not use an outdoor cooking gas appliance for purpose other than intended;
6. When connecting, first connect plug to the outdoor cooking gas appliance then plug appliance into the outlet;
7. Use only a Ground Fault Interrupter (GFI) protected circuit with this outdoor cooking gas appliance;
8. Never remove the grounding plug or use with an adapter of 2 prongs; and
9. Use only extension cords with a 3 prong grounding plug, rated for the power of the equipment, and approved for outdoor use with a W-A marking.

Safe Locations for Use of This Outdoor Grill

CAUTION

Never use this outdoor grill inside any building, garage, shed or breezeway, or inside any boat, trailer or recreational vehicle to prevent a possible fire and to prevent the possibility of carbon monoxide poisoning or asphyxiation.

WARNING

Do not use this appliance under overhead combustible surface or covered area (e.g., awnings, umbrellas, porches or gazebos).

Always confirm that this grill is not positioned under the overhang of a house, a garage or other structure before lighting it. An overhang will serve to deflect flare-ups and radiated heat into the structure itself, which could result in a fire.

Always confirm that this grill is positioned more than 50 inches (1.27 M) away from any building or combustible materials or surface before lighting it, and that no gasoline or

other volatile substances are stored in the vicinity of this grill. (See diagram to right).

The temperature of a grease fire or of the radiated heat might otherwise be sufficient to ignite nearby combustible or volatile substances. Always locate this grill where there will be ample combustion and ventilation air, but never position it in the direct path of a strong wind.

Never allow the grill to operate while unattended to prevent uncontrolled grease fires from erupting.

Never attempt to move this grill while it is in operation or while it is still hot to prevent possible personal injury.

Never store or use gasoline or other flammable or volatile substances in the vicinity of this grill or in the vicinity of any other heat-generating appliance because of the danger of starting a fire.

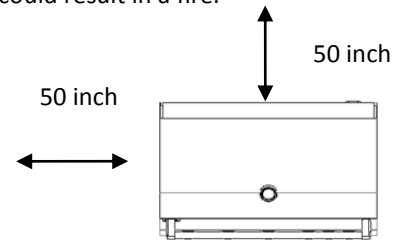

Always confirm that the installation of this grill conforms to the requirements of all local codes or, in the absence of applicable local codes, with the Canadian Standards Association's Natural Gas and Propane Installation Code CSA B149.1.

Always confirm that the outdoor cooking gas grill, when installed, must be electrically grounded in accordance with local codes or, in the absence of local codes, with the National Electrical Code, ANSI/NFPA 70, or the Canadian Electrical Code, CSA C22.1.

DANGER – Gas Safety

Liquid propane (LP) gas is flammable and hazardous if handled improperly. Become aware of its characteristics before using any propane product.

- Propane Characteristics: Flammable, explosive under pressure, heavier than air and settles in pools in low areas.
- In its natural state, propane has no odor. For your safety, an odorant has been added.
- Contact with propane could cause freeze burns to the skin.
- This grill is shipped from the factory for propane gas use only.
- Never use a propane cylinder with a damaged body, valve, collar or footing.
- Dented or rusted propane cylinders may be hazardous and should be checked by your propane gas supplier.

CAUTION

- It is essential to keep the grill's valve compartment, burners and circulating air passages clean.
- Inspect the grill before each use.

Step 1. Inspect all hoses and connections and make certain they are secure.

Step 2. Check and clean the burner venturi tubes for insects and insect nests by removing the burner and inserting a bottle brush cleaner into each tube to make sure the passage is clear.

*** A clogged tube can lead to a fire beneath the grill. ***

Step 3. Ensure that the valve nozzle is pointing straight and completely inserted into the venturi tube.

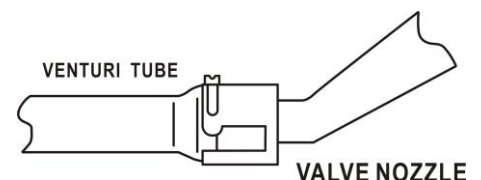

GENERAL INFORMATION

1. A propane gas cylinder is required for operation.
2. This gas grill is NOT intended for commercial use.
3. Don't obstruct the ventilation opening of the cylinder enclosure.

THIS MANUAL APPLIES TO THE FOLLOWING BBQ GRILLS:

BBQ FEATURES:

Model: BCP-500L 5 BURNER



Grill Dimensions	32 7/16"W x 23 1/2"D x 19 5/8"H
BTU Output	15,000 BTU per Burner x4
Infrared Back Burner	12,000 BTU
Total BTU	72,000
Primary Ignition	Push N' Turn Flame Thrower
Secondary Ignition	N/A
Cooking Grid Dimensions	30" X 18"
Total Cooking Area	680sq.in (includes warming rack)
Flame Tamer	Flame Stabilizer Grid
Rotisserie Kit	Optional
Burner	Commercial Quality Cast Steel
Gas Type	Each grill contains an NG/LP Conversion Kit

Warranty	<p>*25 Years – Stainless Steel Burner</p> <p>*5 Years – all other components</p> <p>*Appliances must be registered within 30 days of purchase to validate this warranty.</p> <p>*See warranty section for details.</p>
----------	--

Model: BCP-500S 5 BURNER



Grill Dimensions	32 7/16"W x 23 1/2"D x 19 5/8"H
BTU Output	15,000 BTU per Burner x4
Infrared Back Burner	12,000 BTU
Total BTU	72,000
Primary Ignition	Push N' Turn Flame Thrower
Secondary Ignition	N/A
Cooking Grid Dimensions	30" X 18"
Total Cooking Area	680sq.in (includes warming rack)
Flame Tamer	Flame Stabilizer Grid
Rotisserie Kit (Motor & Forks)	Optional
Burner	Commercial Quality Cast Steel
Gas Type	Each grill contains an NG/LP Conversion Kit

Warranty	<p>*25 Years – Stainless Steel Burner</p> <p>*5 Years – all other components</p> <p>*Appliances must be registered within 30 days of purchase to validate this warranty.</p> <p>*See warranty section for details.</p>
----------	--

Model: BCP-600L 6 BURNER



Grill Dimensions	39 3/4"W x 23 5/8"D x 20 1/2"H
BTU Output	15,000 BTU per Burner x5
Infrared Back Burner	12,000 BTU
Total BTU	87,000
Primary Ignition	Push N' Turn Flame Thrower
Secondary Ignition	N/A
Cooking Grid Dimensions	38" X 18"
Total Cooking Area	870sq.in (includes warming rack)
Flame Tamer	Flame Stabilizer Grid
Rotisserie Kit (Motor & Forks)	Optional
Burner	Commercial Quality Cast Steel
Gas Type	Each grill contains an NG/LP Conversion Kit

Warranty	<p>*25 Years – Stainless Steel Burner</p> <p>*5 Years – all other components</p> <p>*Appliances must be registered within 30 days of purchase to validate this warranty.</p> <p>*See warranty section for details.</p>
----------	--

Model: BCP-600S 6 BURNER



Grill Dimensions	39 3/4"W x 23 3/8"D x 19 3/8"H
BTU Output	15,000 BTU per Burner x5
Infrared Back Burner	12,000 BTU
Total BTU	87,000
Primary Ignition	Push N' Turn Flame Thrower
Secondary Ignition	N/A
Cooking Grid Dimensions	38" X 18"
Total Cooking Area	870sq.in (includes warming rack)
Flame Tamer	Flame Stabilizer Grid
Rotisserie Kit (Motor & Forks)	Optional
Burner	Commercial Quality Cast Steel
Gas Type	Each grill contains an NG/LP Conversion Kit

Warranty	<p>*25 Years – Stainless Steel Burner</p> <p>*5 Years – all other components</p> <p>*Appliances must be registered within 30 days of purchase to validate this warranty.</p> <p>*See warranty section for details.</p>
----------	--

Model: BCP-5001L



Side Burner Dimensions	24.8"W x 12.6"D x 9.5"H
BTU Output	12,000 BTU per Burner x2
Infrared Back Burner	N/A
Total BTU	24,000
Primary Ignition	Push N' Turn Flame Thrower
Secondary Ignition	N/A
Flame Tamer	Flame Stabilizer Grid
Burner	Stainless steel
Gas Type	Each grill contains an NG/LP Conversion Kit
Warranty	<p>*25 Years – Stainless Steel Burner</p> <p>*5 Years – all other components</p> <p>*Appliances must be registered within 30 days of purchase to validate this warranty.</p> <p>*See warranty section for details.</p>

Model: BCP-5001S



Side Burner Dimensions	23.6"W x 18.9"D x 5.3 "H
BTU Output	12,000 BTU per Burner x2
Infrared Back Burner	N/A
Total BTU	24,000
Primary Ignition	Push N' Turn Flame Thrower
Secondary Ignition	N/A
Flame Tamer	Flame Stabilizer Grid
Burner	Stainless steel
Gas Type	Each grill contains an NG/LP Conversion Kit
Warranty	<p>*25 Years – Stainless Steel Burner</p> <p>*5 Years – all other components</p> <p>*Appliances must be registered within 30 days of purchase to validate this warranty.</p> <p>*See warranty section for details.</p>

BBQ SPECIFICATIONS

BCP-500L

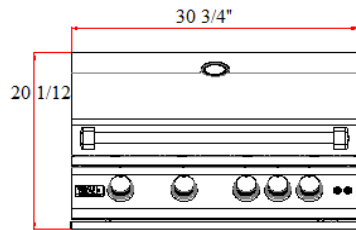

Broilchef 5Bnr

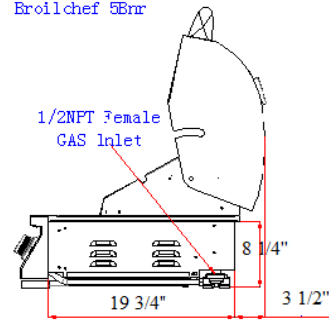

BCP-500S BROILCHEF 5BNR

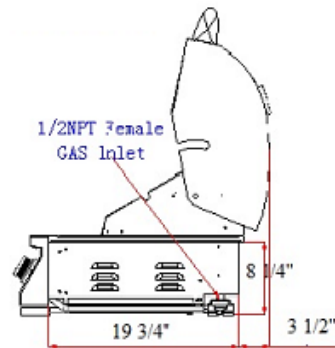
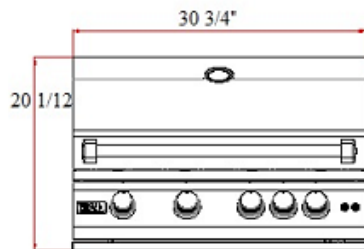

ECP-600L

Broilchef 6Bnr

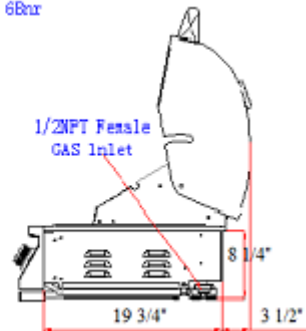
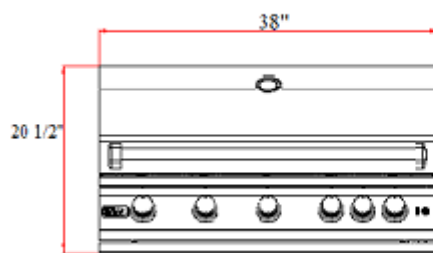

BCP-600S 6BNR

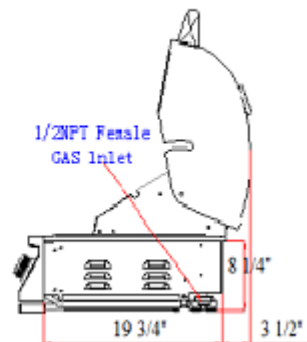
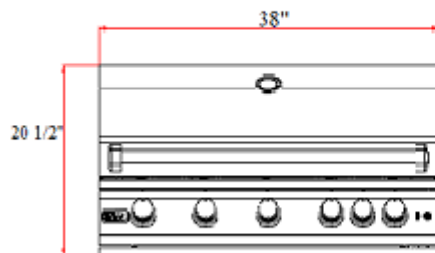

GRILL PARTS

Thermometer	BCP-500L-01-01	6 Burner Body Bottom	BCP-600L-01-15
Thermometer Base	BCP-500L-01-02	Cooking Grid	BCP-500L-01-16
5 Burner Lid	BCP-500L-01-03	Lava Stone Heat Sheet	BCP-500L-01-17
6 Burner Lid	BCP-600L-01-03	Burner Ignite Plate	BCP-500L-01-18
Lid Pin	BCP-500L-01-04	Burner	BCP-500L-01-19
Handle Seat	BCP-500L-01-05	Oil Baffle	BCP-500L-01-20
5 Burner Handle Tube	BCP-500L-01-06	5 Burner Main Valve	BCP-500L-01-21
6 Burner Handle Tube	BCP-600L-01-06	6 Burner Main Valve	BCP-600L-01-21
5 Burner Warming Rack	BCP-500L-01-07	Knob Lamp	BCP-500L-01-22
6 Burner Warming Rack	BCP-600L-01-07	5 Burner Control Panel	BCP-500L-01-23
Lamp	BCP-500L-01-08	6 Burner Control Panel	BCP-600L-01-23
5 Burner Body Top	BCP-500L-01-09	Logo Plate	BCP-500L-01-24
6 Burner Body Top	BCP-600L-01-09	Knob Bezel	BCP-500L-01-25
Rotis Burner	BCP-500L-01-10	Knob	BCP-500L-01-26
Ignition Needle Cover	BCP-500L-01-11	Knob Lamp Switch	BCP-500L-01-27
Nozzle Cover Plate	BCP-500L-01-12	5 Burner Grease Pan	BCP-500L-01-28
Nozzle	BCP-500L-01-13	6 Burner Grease Pan	BCP-600L-01-28
Rotis Burner Igniter	BCP-500L-01-14	Regulator	BCP-500L-01-29
5 Burner Body Bottom	BCP-500L-01-15	Venturi Tube	BCP-500L-01-30

BCP 5 Burner

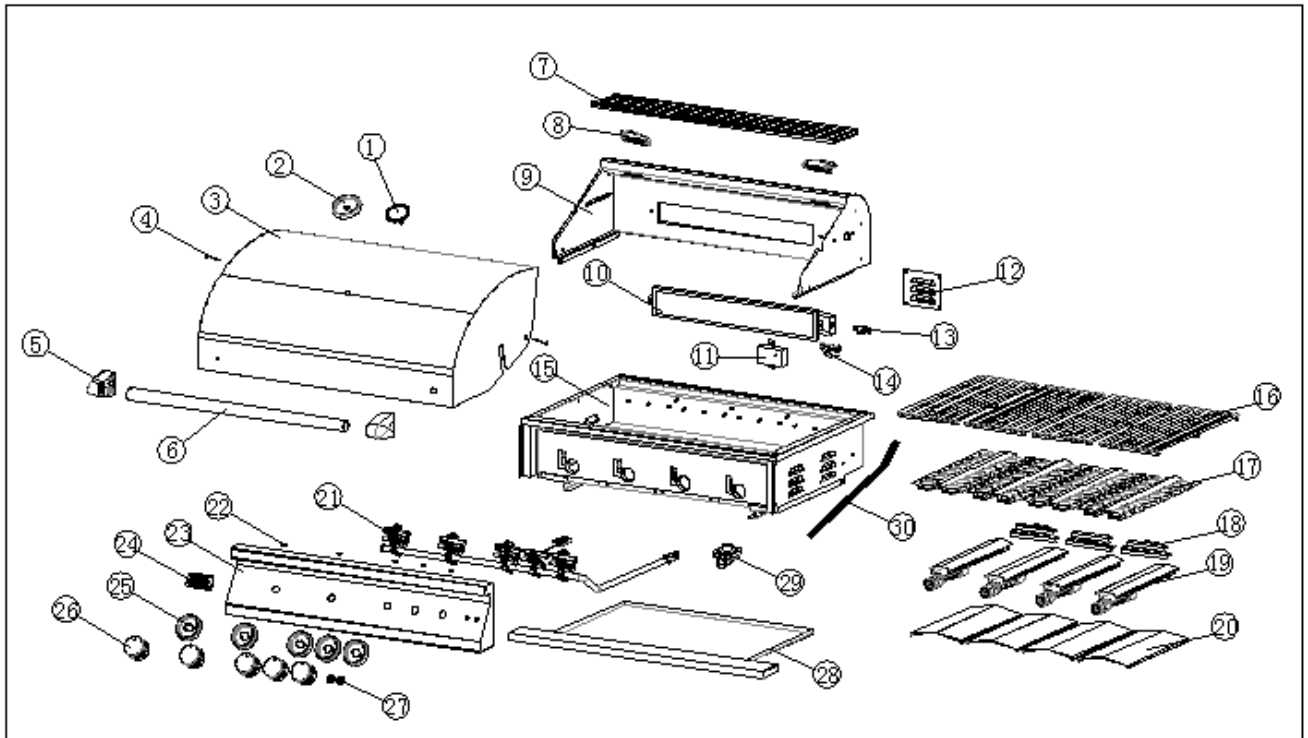

BCP500S has no Part#22 (Knob Lamp) and Part#27 (Lamp Switch).

BCP 6 Burner

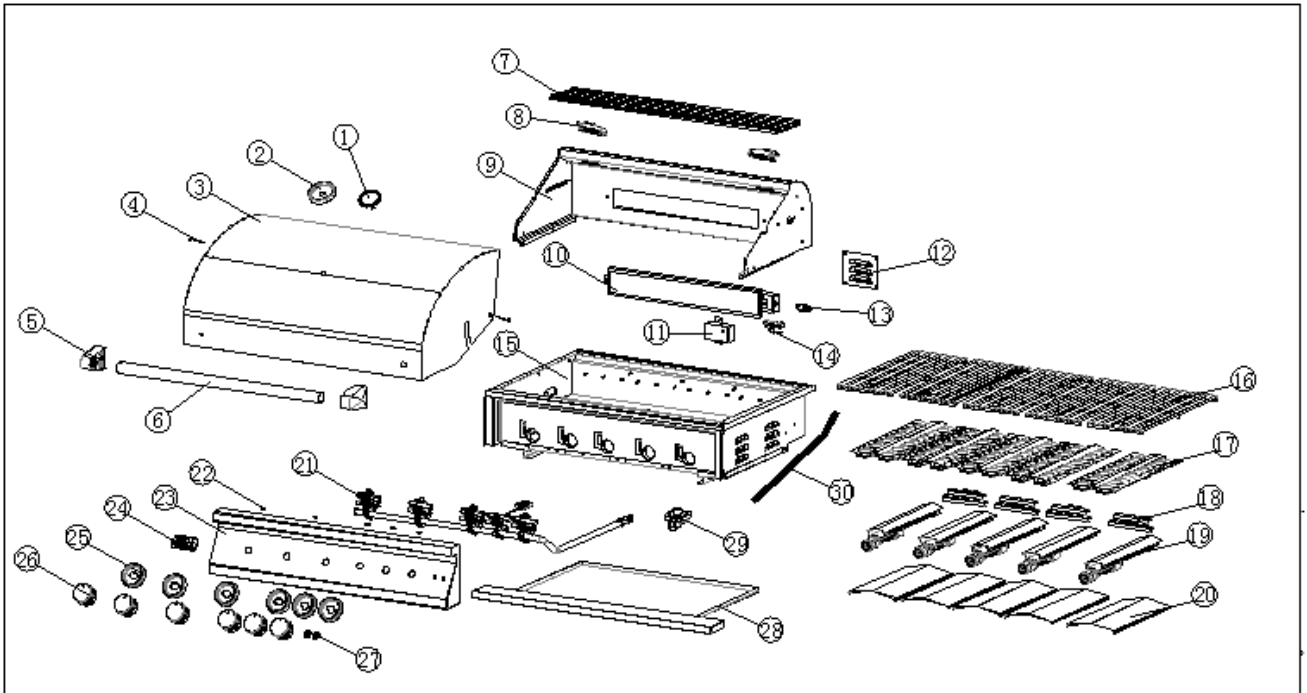

BCP600S has no Part#22 (Knob Lamp) and Part#27 (Lamp Switch).

Installing the Appliance in a BBQ Island

You will need a second person to help you avoid damaging the appliance or your appliance island.

The island must be made out of non-combustible material. In the event it is combustible, the use of an insulation jacket is required.

Before installing an appliance in any island cut out, make sure that the opening is not bigger than the outside frame of the appliance unit. The appliance should rest on the lip of the frame.

Pay careful attention to the location of the gas line. It should be routed away from sources of heat, sharp edges and should make as few bends as possible.

Check to see if the gas line connection will be accessible when appliance is installed.

If the gas line connection is not easily accessible when the appliance is installed, support the appliance above counter level and attach the gas line to the appliance. When the gas connection is made, slide the appliance into the cut-out. If the gas line connection is accessible when the appliance installed, slide the appliance into the cut-out and then attach the gas line.

Be very careful not to kink the gas line when lowering the appliance into the cut out.

Keep your fingers away from where the appliance will be supported on counter. Your fingers could become trapped and serious injury could occur.

Check to make sure the appliance is level and is supported around the entire outside edge. If the appliance is not level or is unstable, use non-combustible shims under the outside lip to stabilize it.

Perform the leak test procedure as described earlier in this manual.

BUILDING BBQ SPECIFICATIONS

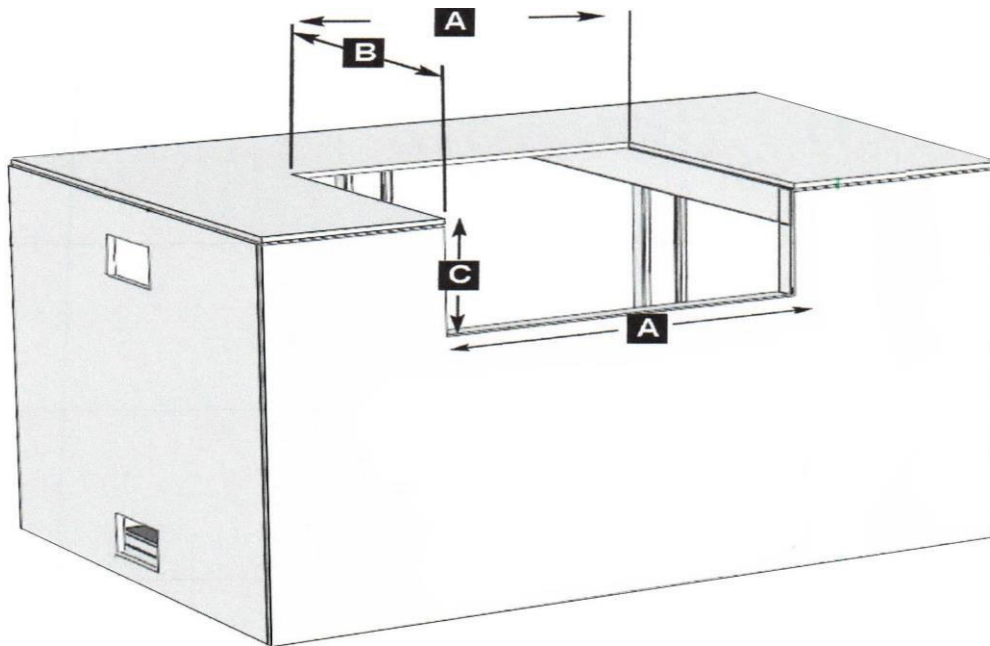

ALL BBQ ISLANDS MUST BE MANUFACTURED FROM "NON-COMBUSTIBLE" MATERIAL.

Minimum clearance to adjacent combustible construction at 14" from sides & 16" from back

Cut-Out Dimensions

MODEL	DESCRIPTION	WIDTH (A)	DEPTH (B)	HEIGHT (C)
BCP-500L	32" 5 Burner	30 3/4"	19 3/4"	8 1/4"
BCP-500S	32" 5 Burner	30 3/4"	19 3/4"	8 1/4"
BCP-600L	40" 6 Burner	38"	19 3/4"	8 1/4"
BCP-600S	40" 6 Burner	38"	19 3/4"	8 1/4"
BCP-5001L	Double Burner	11"	21"	2 1/2"
BCP-5001S	Double Burner	22 1/4"	17 1/4"	2 1/2"

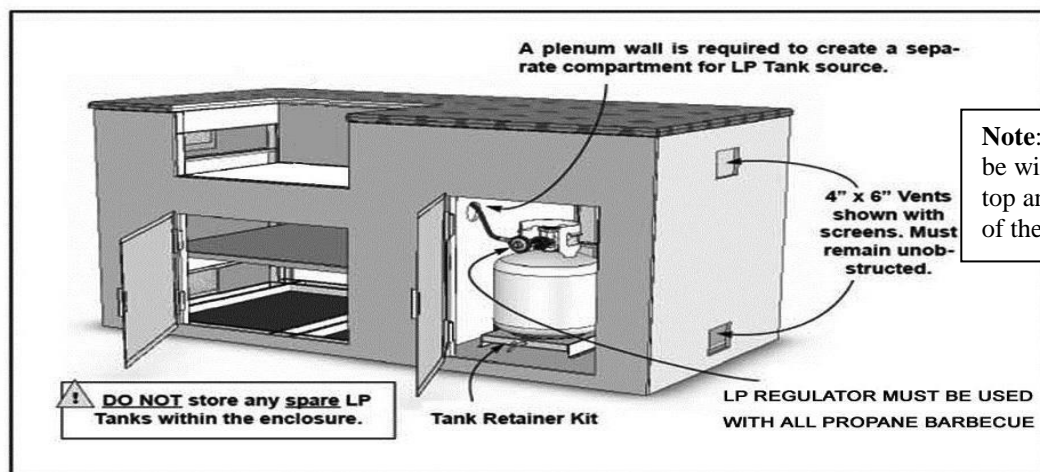

Note: the vents should be within 5 inches of the top and within one inch of the bottom

INSTALLATION METHOD

Installation Method for Propane for BCP-500L.(S), BCP-600L.(S)

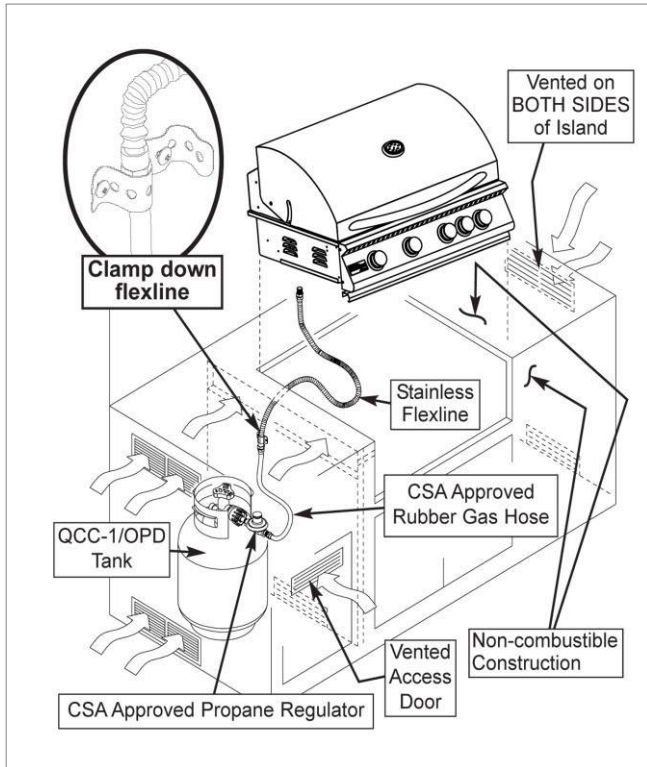

- (A) Open barbecue door. Install hose with regulator on propane tank. Then connect the other end to "T" adapter. Make sure to use gas rated tape seal when installing adapter to insure proper seal.

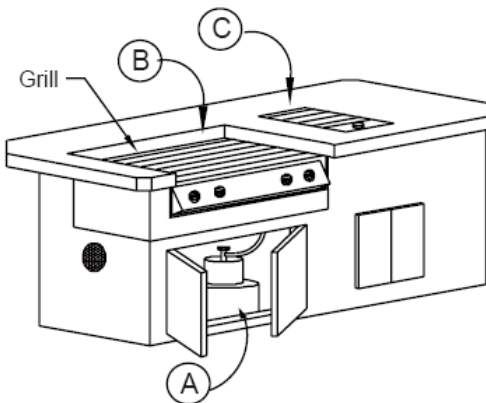

- (B) Then take other end of "T" adapter with hose attached and connect to end of male located underneath and at the back of the grill. (Use gas rated tape seal on all connections).
- (C) Connect the last open line to the side burner (Use gas rated tape seal on all connections)

Installation Method for Side Burner with a Grill

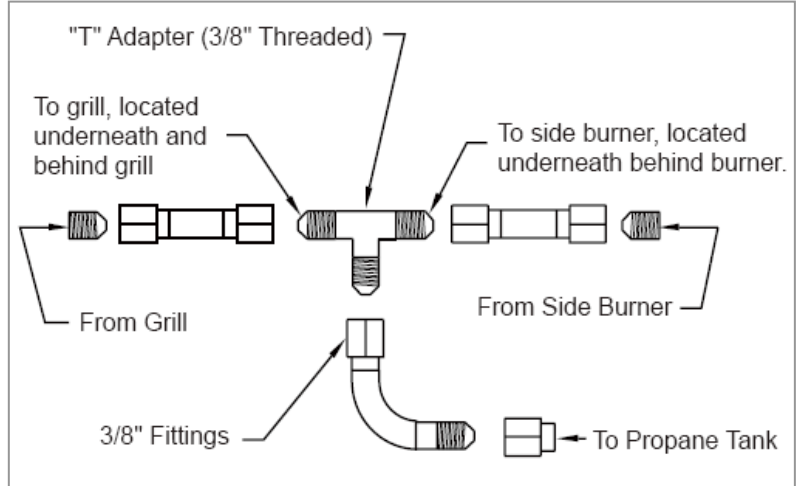

NOTE: You will need to use a gas rated sealer on gas connectors that are not flared.

Installing Side Burner with a Built-in Grill

If you are installing a side burner in conjunction with a gas grill, install it in the following manner:

1. Assemble a 3/8" pipe nipple to the 3/8" pipe tee using Teflon tape or pipe sealant.
2. Use only sealant that is approved for use on LP gas. Install the pipe tee assembly to the grill intake pipe.
3. Tighten assembly and align the branch opening of the tee with the hole of the cabinet. Connect the flexible hose (male end) to the pipe tee.
4. Install and secure the side burner into the island by simply setting it in place.
5. Connect the female end of the flexible hose to the side burner intake pipe.
6. Connect gas supply to the grill.
7. Check for gas leaks using soapwater solution

Natural Gas Conversion

When converting an LP side burner that is connected to an LP grill, you MUST convert both appliances. It is dangerous to have an LP appliance and an NG appliance supplied by the same fuel.

BroilChef Premium side burners and built-in grills are manufactured to use standard liquid propane (LP) and can be converted to burn natural gas (NG). You will need tools, 2 NG orifices for side burners and 6 or 7 NG orifices for built-in grills (depending on the size of the grill). Only the NG orifices are supplied to do the conversion, tools are not provided.

Tools Required to Convert Side Burner and Grill from LP to NG:

1. 7mm and 6mm Socket Wrench
2. 10mm Open Wrench
3. #2 Phillips Screwdriver
4. Needle Nose Pliers



You must have an authorized service technician perform this procedure. If these instructions are not followed exactly, a fire or explosion may result causing property damage, personal injury or loss of life. BroilChef Premium will not be held responsible for an improperly converted gas side burner.

Before you begin, make certain the LP gas source has been disconnected.

Replacing Side Burner's Orifices (BCP5001L & BCP5001S):

1. Remove the grate, burner cap and burner diffuser from the side burner.
2. Using a 7mm socket wrench undo the propane orifices from the burner.

(See illustration below).

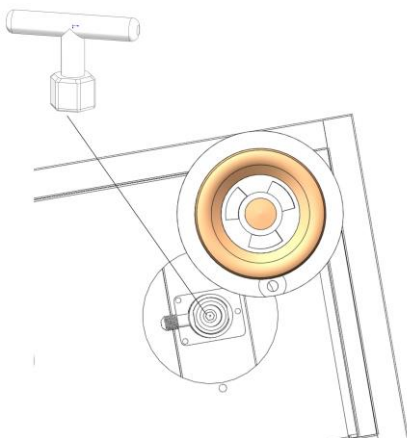

3. After all the propane orifices are removed from the main burner valve, place them in a safe spot away from your work area. This will ensure that you do not re-install the Propane orifices.
4. Replace the Orifices with the New Natural Gas Orifices supplied. Tighten the orifice with the 7mm socket wrench.
5. Put back the burner diffuser, burner cap and grate.

Replacing the Built-In Grill's Orifices (BCP500S/BCP500L/BCP600S/BCP600L):

Main Burner Valve Assembly

1. Remove the Cooking Grids and Upper Flame Tamers.
2. Remove the Cotter Pins that holds the burners at the back of the grill by using a screwdriver or needle nose pliers. (See illustration below left).

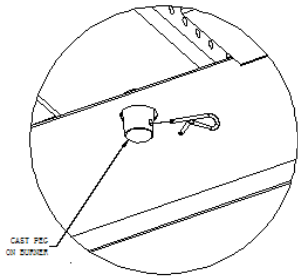

3. Remove burners from the grill insert.
4. Using a 6mm socket wrench undo all of the main burner orifices from the underside of the Control Panel. (See illustration below).

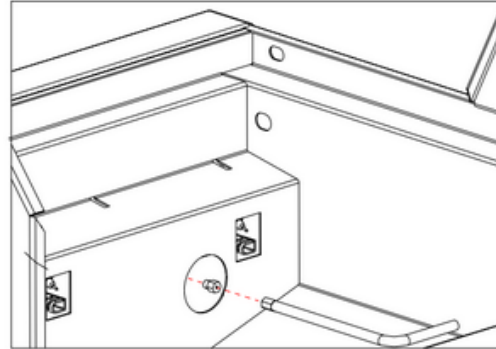

5. After all the Propane orifices are removed from the main burner valve, place them in a safe spot away from your work area. This will ensure that you do not re-install the Propane orifices.
6. Replace the Main Burner Orifices with the New Natural Gas Orifices supplied.
7. Re-install the Main Burners. Ensure that each burner is properly placed over the Main Burner orifice.
8. Re-install the Hair Pins that holds the burners at the back of the grill.
9. Re-install the Cooking Grids and Upper Flame Tamers.

Rear Burner:

1. Using a #2 Phillips Screwdriver undo the 4 screws that hold the Back Cover Plate to the Inner Hood. (See illustration below left).

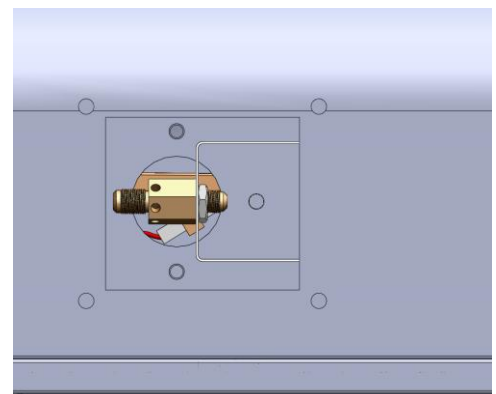
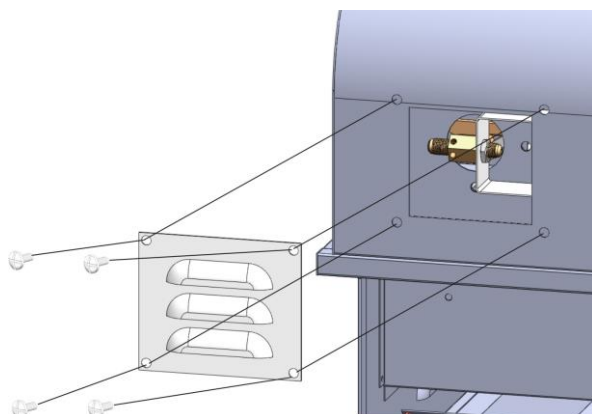

2. Once the cover has been removed use a 10mm Open Wrench to remove the Rear Burner Orifice from the Rear Burner (See illustration above right). Place the Propane Rear Orifice with the propane orifices you removed previously.
3. Install the New Natural Gas Orifices supplied using the Open Wrench.
4. Re-install the Rear Burner Cover using the 4 screws previously removed.

REMEMBER TO LEAK CHECK ALL FITTINGS AND ORIFICES AFTER ALL OF THE CONVERSION IS COMPLETED. TEST FIRE ALL BURNERS TO ENSURE PROPER AND SAFE OPERATION.

⚠️ WARNING.

This outdoor cooking gas appliance is equipped with a three-prong (grounding) plug for your protection against shock hazard and should be plugged directly into a properly grounded three-[prong receptacle. Do not cut or remove the grounding prong from this plug.

Installing Light Adaptor:

In order to ensure AC Adaptor (Power Output: 24VAC, 2500mA Maximum Power Output: 60W Input Requirement: 120VAC, 60Hz, 1000mA; UL Approved) and interior lights system longevity, the adaptor must be installed at least 6" above the ground. The adaptor may be attached to your island material using metal screws. To install your adaptor, secure 4 screws (not provided) through the designed mounting tabs (See illustration right.)

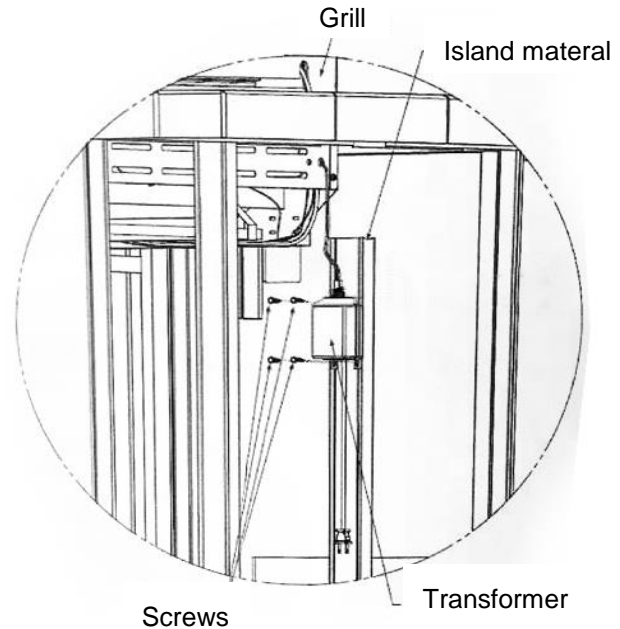

Operating Your Grill

⚠️ CAUTION

Use only the regulator provided. If a replacement is necessary, call our customer service center. The use of unauthorized parts can create an unsafe condition and environment.

The liquid propane gas (LP-gas) supply cylinder(s) to be used must be:

- a) Constructed and marked in accordance with the *Specifications for LP-Gas Cylinders* of the U.S. Department of Transportation (D.O.T) or the National Standards of Canada, CAN/CSA-B339, *Cylinders, Spheres and Tubes for Transportation of Dangerous Goods; and Commission*, as applicable; and
- b) Provided with a listed over-filling prevention device;
- c) Provided with a cylinder connection device compatible with the connection for outdoor cooking appliances.

Only the pressure regulator and hose assembly supplied with the outdoor cooking gas appliance must be used. Replacement pressure regulators and hose assembly must be those specified by the outdoor cooking gas appliance manufacturer. Use only 20-pound cylinders equipped with a cylinder connection device compatible with the connection for outdoor cooking appliances. The cylinder must include a collar to protect the cylinder valve. Do not drop or handle the cylinder roughly. Disconnect the propane cylinder from the regulator valve when the grill is not in use.

Storage of the appliance indoors is permissible **ONLY** if the cylinder is disconnected and removed from the appliance. Store cylinder outdoors and keep out of the reach of children. Do not store the cylinder in a building, garage or other enclosed areas. Never store your cylinder where temperatures can reach over 51.7°C.

Before connecting, make sure there is no debris caught in the head of the gas cylinder, regulator valve or in the head of the burner and burner ports. Connect regulator valve and hand tighten firmly. **DO NOT** obstruct the flow of combustion air or ventilation air to the grill. Ensure the propane cylinder is in an upright position to allow the gas to leave the cylinder. Otherwise the overfill prevention device within the cylinder will prevent proper gas flow.



A fire causing death or serious injury may occur if the following is not followed exactly:

- Never store or use gasoline or other volatile substances in the vicinity of this grill.
- Never store a spare propane cylinder in the vicinity of this grill, or in the vicinity of another potential heat source.
- Never fill the propane cylinder beyond 80% full.



Don't store spare gas cylinder in or near grill.

Connecting & Disconnecting the Gas Cylinder

LP (Propane) Gas Supply Connection & Disconnection

1. Always place the propane cylinder on the tank brackets located on the right side of the cart.
2. Always confirm all burner control knobs are in the OFF position before activating the gas supply.
3. Before connection, be sure that there is no debris caught in the head of the gas cylinder, head of the regulator valve, or in the head of the burner and burner ports.
4. Always connect the gas supply regulators as follows: Insert the nipple of the valve coupling into the tank valve and tighten the connection collar by turning it clockwise with one hand while holding the regulator with the other hand. (See diagram to right.)
5. Disconnect the propane cylinder from the regulator valve when the grill is not in use.
6. Always confirm all burner control knobs are in the OFF position before disconnecting the gas supply.
7. Before disconnecting, be sure that the tank valve is in OFF position.
8. Always disconnect the gas supply regulators as follows: Loosen the connection collar by turning it counter-clockwise with one hand while holding the regulator with the other hand and take the nipple of the valve out of the tank valve (See diagram to right.) Do not obstruct the flow of combustion air and ventilation air to the grill. Keep ventilation openings of the cylinder enclosure free and clear from debris.
9. Place dust cap on cylinder valve outlet whenever the cylinder is not in use. Install only the type of dust cap on cylinder valve outlet that is provided with the cylinder valve. Other types of caps or plugs may result in leakage of propane.



To prevent fire or explosion hazard when testing for a leak:

1. Always perform the "leak test" as below before lighting the grill and each time the cylinder is connected for use.
2. Do not smoke or allow other sources of ignition in the area while conducting a leak test.
3. Conduct the leak test outdoors in a well-ventilated area.
4. Do not use matches, lighters or a flame to check for leaks.
5. Do not use grill until all leaks have been stopped. If you are unable to stop a leak, disconnect the propane supply, call for gas appliance service or your local propane gas supplier.

Checking for Leaks

1. Make 2-3 oz. of leak solution by mixing one part liquid dishwashing soap with three parts water.
2. Make sure control knobs are in the "OFF" position.
3. Spray some solution on the tank valve up to the regulator connection. (See diagram to right.)
4. Inspect the solution at the connections for bubbles. If no bubbles appear, the connection is secure.
5. If bubbles appear, you have a leak. Proceed to step 6.
6. Disconnect the regulator from the tank and reconnect. Make sure the connection is secured.
7. Retest with solution.
8. If you continue to see bubbles, replace the cylinder.



Lighting Your Grill



Failure to open lid while igniting the grill's burners or not waiting five minutes to allow gas to clear if the grill does not light, may result in an explosion, which could cause serious bodily injury or death.

WARNING

Never stand with your head directly over the grill when preparing to light the main burners, to prevent possible bodily injury.

Lighting Main Burner

WARNING:

Attempting to light the burner with the lid closed may cause an explosion. Make sure there are no obstructions of airflow to the gas unit. Spiders and insects can nest and clog the burner/venturi tube at the orifice. A clogged burner tube can lead to a fire beneath the appliance.

1. Open lid while lighting burners.
2. Make sure all control knobs are in the "OFF" position.
3. Turn on gas source or cylinder valve.
4. Ignite only the burners you wish to use. Push and turn the knob to "HIGH" then press the igniter button immediately. The burner should light. If the burner does not light, repeat 2 or 3 times.
5. If ignition does NOT occur in 5 second turn the burner controls to OFF, wait 5 minutes, and repeat the lighting procedure.
6. To ignite remaining burners, repeat the step 4 and 5 for each burner.
7. Adjust valve knob(s) to desired cooking temperature.

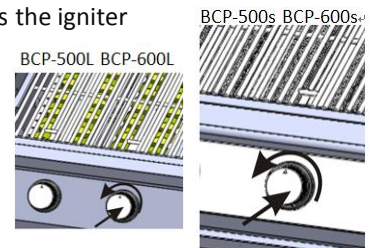

PRECAUTIONS:

1. After lighting, observe the burner flame. Make sure all burner ports are lit.
2. If the burner flame goes out during operation, immediately turn the gas "OFF". Open lid to let the gas clear for at least 5 minutes before re-lighting.
3. Before cooking on the grill for the first time and operate the grill for approximately 15 minutes with the lid closed and the gas turned on "HIGH". This will "heat clean" the internal parts, dissipate odor from the manufacturing process and painted finish.
4. Clean the grill after each use. **DO NOT** use abrasive or flammable cleaners. This may damage parts of the grill and cause a fire.

Flame Adjustment

Become familiar with the safety instructions at the front of this manual. Do not smoke while lighting the appliance or checking the gas supply connections.

- ☐ Make sure that all gas connections are securely tightened and have been leak-tested with a soapy water solution - never with a flame!
- ☐ With the cooking grids and flame tamers removed, light the main burners and run them on the high setting.
- ☐ Inspect burners for proper flame appearance. The ideal flame appearance is one that is mostly blue and not lifting off of the burner surface. There is an air shutter found at the end of the burner (close to the valve) which can be either opened or closed to make adjustments to the flame's appearance. To adjust, remove the burner from the appliance and loosen the phillips head screw holding the air shutter to the burner. If the flame is yellow, open the air shutter to make the flame bluer. If the flame is lifting off of the burner surface, slightly close the air shutter. Re-tighten the phillips head screw and re-install the burner to recheck the flame appearance. Repeat if necessary.
- ☐ Turn burners to low flame setting and test for proper flame height. Flame should stand between $\frac{1}{4}$ " – $\frac{1}{2}$ " on LOW. (To adjust the LOW flame setting simply light the appliance on the LOW setting and adjust the screw located under the knob on the front of the valve using a flat head screwdriver as seen in the diagram below.)

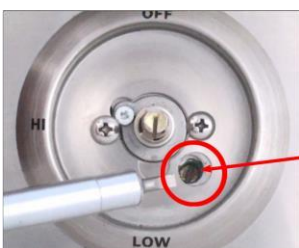

**Low flame setting
screw**

If the burner does not light after several attempts, immediately close all gas valves and consult an authorized service technician. Before cooking with your appliance for the first time, burn off any foreign matter and rid the unit of any odors by burning the unit on HIGH with the lid down for about 10 minutes. When lit, the flame should have a mostly blue color to it. It may have a tint of yellow and adjustment to the air shutters can be made to obtain a blue flame and proper gas glow. This appliance should be

preheated before cooking with the main burner control settings on HIGH for five minutes with the lid closed.

WARNING

Adjusting the air-shutter while the grill is operating. If it is still hot, please wear protective gear and be careful. Failure to follow this instruction could cause personal injury.

Flare-Ups

“Flare-ups” sometimes occur when food drippings fall onto the hot heat distribution plate or burners and ignite. Some flaring is normal and desirable as it helps impart the unique flavors associated with grilled foods. Controlling the intensity of the flare-ups is necessary, however, in order to avoid burned or unevenly cooked foods and to prevent the possibility of accidental fire.

WARNING

Always monitor the grill closely when cooking and turn the flame level down to LOW or OFF if flare-ups intensify.

Shutting Off Burners

1. Always turn the valve knob(s) clockwise to the “HIGH” position, and then press and turn it to “OFF”. Never force the knob without pressing it. This could damage the valve.
2. Promptly turn the gas supply to the “OFF” position at the propane cylinder.
3. Close the lid of the grill.

Excess Flow Safety Valve Reset Procedure

- The new regulators are equipped with a safety device that restricts the gas flow in the event of a gas leak. However, unsafe practices of grill operation could activate the safety device without having a gas leak.
- A sudden shut off of the gas flow typically occurs if you open the liquid propane (LP) tank valve rapidly, or if one or more of the burner control knobs is in an open position when opening the LP tank valve.
- This procedure is effective with all sizes of LP tank.
- To ensure the procedure is safely and successfully performed, please carefully follow these instructions:
 1. Close the LP tank valve.
 2. Turn all burner control knobs to the OFF position.
 3. Disconnect the regulator from the LP tank.
 4. Open the lid of the grill.
 5. Turn burner control knobs to HIGH.
 6. Wait at least 1 minute.
 7. Turn burner control knobs OFF.
 8. Wait for at least 5 minutes.
 9. Re-connect the regulator to the LP tank.
 10. Slowly turn the LP tank valve ¼ turn at a time and have the valve all the way open.
 11. With the lid open: For grill with ignition button: turn on only ONE front burner control knob to the HIGH position. Ignite the grill by pushing the ignition button. For grill with an automatic ignition: Push down the control knob you want to light, turn counterclockwise until you hear the ignition click.
 12. After the first front burner is lit, turn on the other control knob(s) to the HIGH position. **If you have more than two burners, turn them on only ONE AT A TIME.
 13. When all front burners are lit, close the grill lid.
 14. Wait for 10-15 minutes; the temperature should reach 400 – 450°F

WARNING

The cylinder valve always has to be in the horizontal position, to ensure that only the propane vapour is withdrawn.

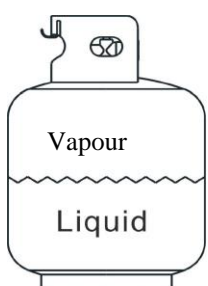

CORRECT

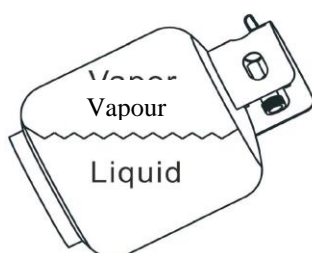

WRONG

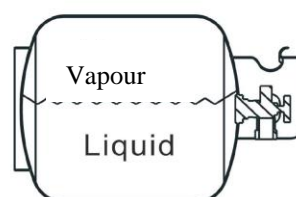

WRONG

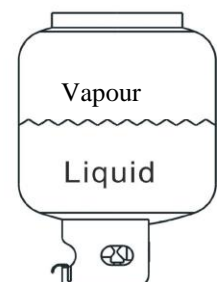

WRONG

Care and Maintenance

IMPORTANT

Always allow to completely cool off before covering your grill to prevent corrosion from condensation.

CAUTION

All cleaning and maintenance should be done when the grill is cool, with the fuel supply turned off at the control dial and the propane cylinder disconnected. DO NOT clean any grill part in a self-cleaning oven. The extreme heat will damage the finish.

Cleaning Your Appliance

NOTE: You should clean your appliance after each use to maintain the overall appearance over the life of your appliance. After the first use, it is normal for your appliance to become discolored in certain areas from the heat produced by the burners.

Exterior Cleaning

When cleaning your appliance, always scrub and polish in the direction of the stainless steel grain. Wipe down the exterior of the appliance to remove any splatter or grease. Do not use harsh abrasives. Use a stainless steel cleaner to clean the exterior surface for a polished look. To remove baked-on foods, use a fine to medium grit non-metallic abrasive pad with a stainless steel cleaner to avoid specks of grease collecting in the grain causing the appearance of rust. Before installing the cover, always allow the surface to dry. DO NOT cover a damp appliance.

Drip Tray

Clean the drip tray after each use. Failure to do so could result in a fire. Once the appliance has cooled completely, remove the tray by pulling it all the way out until it comes free. Clean the tray with hot soapy water and re-install. If using an oven cleaning agent, be sure to carefully follow the manufacturer's instructions to avoid damage to the stainless steel.

Heat Separators, Flame Tamers, Grilling and Warming Racks

To clean after each use, turn the appliance on HIGH for 10-15 minutes with the lid closed. This allows any food particles or grease drippings to burn away. Brush components to remove any remaining charred materials. The appliance must be completely cooled before proceeding. Make sure the gas supply is off and all control knobs are in the "OFF" position. You must remove all cooking grids and flame tamers to expose the main burners in the appliance. On the bottom rear of each burner is a cotter pin. Remove cotter pin. To remove burner, pull rod upwards and slide burner toward the rear of the appliance. Repeat for each burner. To clean the burners, use a wire brush to clean the exterior of the burner. Free all clogged ports of obstructions with a small metal object. Clean out any debris through the air shutter and inspect the burner inlet to ensure it is free of any obstructions. Use a rod or pipe cleaner to remove any debris within the burner if necessary.

Burner Assembly

1. Turn gas off at the control knobs and propane tank.
2. Remove cooking grates and heat plate.
3. Remove grease cup.
4. Remove burner by unscrewing nut from beneath burner "foot" using a screwdriver and pliers.
5. Lift burner up and away from the gas valve orifice.
6. Clean inlet (venturi tube) of burner with small bottle brush or compressed air.
7. Remove all food residue and dirt on outside of burner surface.
8. Clean any clogged ports with a stiff wire (such as an opened paper clip).
9. Inspect burner for damage (cracks or holes). If damage is found, replace with a new burner. Reinstall burner. Make certain the gas valve orifices are correctly positioned, pointing straight into burner inlet (venturi tube). Also, check position of spark electrode.

NOTE: Make sure each burner is properly placed after cleaning. It is very important to ensure the end of the burner is installed appropriately onto the gas valve to ensure gas flows safely into the burner. Failure to meet these conditions can cause dangerous conditions that can cause personal injury and/or property damage.

TROUBLESHOOTING

Problem	Possible cause	Prevention/Cure
Burner doesn't light using knobs or igniter	Wires or electrode is covered by cooking residue	Clean wire or electrode using a cloth and rubbing alcohol
	Electrode and burners are wet	Wipe with dry cloth
	Ignition electrode cracked or broken; sparking where cracked	Replace electrode
Burner doesn't light using a match	No gas flow	Check if propane tank is empty. If not, refer to Excessive flow safety valve reset procedure
	Coupling nut and regulator are not fully connected	Unscrew coupling nut about 1/2 to 3/4 turn counterclockwise to disengage, then restart threading the nut. Tighten by hand ONLY, do not use tools.
	Blockage of gas flow	Check burner tube and hose
	Disconnection of burner and valve	Reconnect
	Spider webs or insect nest in venturi	Clean venturi
Sudden drop in gas flow or reduced flame height	Burner ports clogged or blocked	Clean burner ports
	Out of gas	Replace cylinder
Irregular flame pattern, flame does not run the full length of burner	Burner ports are clogged or blocked.	Clean burner ports
Flames turn yellow or orange	New burner may have residual manufacturing oils	Burn your grill for 15 minutes with the lid closed
	Spider webs or insect nest in venturi	Clean venturi
	Food residue, grease or seasoning salt on burner	Clean burner
	Poor connection of valve to burner venturi	Assure burner venturi is properly connected with valve
Flame blows out	High or gusting winds	Turn front of grill to face wind or increase flame height
	Low on propane gas	Replace cylinder
	Excess flow valve tripped	Refer to Excessive flow safety valve reset procedure

Flare-up	Grease fill-up	Clean grill
	Excessive fat in meat	Trim fat from meat before grilling
	Excessive cooking temperature	Adjust (lower) temperature
Persistent grease fire	Grease trapped between burner and food on the grate	Turn knobs to OFF. Turn gas OFF at propane tank. Leave lid in closed position and let fire burn out. After grill cools, remove and clean all parts
Flashback(fire in burner tubes)	Burners or tubes are blocked	Clean burners or tubes
Surface of inside lid appears to be peeling away	The lid is stainless steel and is not painted	Baked on grease fill-up has turned to carbon and is flaking off. Clean thoroughly
Irregular flame	Air flow is not correct. Correct flame is blue with yellow tips 1-2" high.	
	Too little air: wavy yellow or orange flames.	If flames are yellow or orange – open flap at the end of the venturi tubes in 3mm(1/8 in.) increments until flames are correct.
	Too much air: noisy blue flames	If flames are blue and noisy – close flap at the end of the venturi tubes in 3mm (1/8 in.) increments until flames are correct. *Propane Models must be open a minimum of 3mm (1/8 in.)

Warranty Program

Proof of purchase is required to access this warranty program, which is in effect from the date of purchase. If unable to provide proof of purchase or after the warranty has expired, customers will be subject to parts, shipping and handling fees.

Full 30-Day Warranty

Any missing parts can be replaced at no charge within 30 days from the date of purchase with a valid proof of purchase. Customers will be subject to shipping and handling fees.

Limited Warranty

Grill cannot be returned or refunded after using.

25 Years Warranty on Stainless Steel Burners.

5 Years Limited Warranty on all grill parts in regards to damage affecting the operation of the gas grill.

Warranty Provisions:

- This warranty is non-transferable and does not cover failures due to misuse or improper installation or maintenance.
- This warranty is for replacement of defective parts only. We are not responsible for incidental or consequential damages or labor costs.
- This warranty does not cover chips and scratches of porcelain or painted surfaces, nor does it cover corrosion or discoloration due to misuse, lack of maintenance, hostile environment, accidents, alterations, abuse or neglect.
- This warranty does not cover damage caused by heat, abrasive and chemical cleaners, resulting in chipped porcelain enamel parts or any damage to other components used in the installation or operation of the gas grill.

The original consumer purchaser will be charged for all shipping and handling fees of replacement under the terms of limited warranty. If a customer is unable to provide proof of purchase or after the warranty has expired, customers will be also subject to parts fees.

Some provinces do not allow the limitation or exclusion of incidental or consequential damages, so the above limitations or exclusions may not apply to you. This warranty gives you specific legal rights, and you may also have other rights that vary from province to province.

If you have any questions about our products or warranty, please call our service center at 1-877-885-8227 (TOLL-FREE), 10:00 A.M. – 7:00 P.M. (EST), MONDAY-FRIDAY.

Broilchef Premium Built-in Accessories



BCD2417
Single door
CUT-OUT: 24 1/4" X 17 1/2"



BCD2424
Double door
CUT-OUT: 21" X 20 1/4"



BCD3224
Double door
CUT-OUT: 28 3/4" X 20 1/4"



BCD2D3221
Double drawer and door combo
CUT-OUT: 30 1/2" X 20 1/2" X 20 3/4"



BCD3315
Masonry drawer
CUT-OUT: 31 1/4" x 13 1/2" x 19 1/2"



BCD1510
Paper towel holder
CUT-OUT: 13 1/2" x 8 1/4" x 7 1/4"



BCD2D1622
Double drawer
CUT-OUT: 14 1/2" x 20 1/2" x 17 1/2"



BCD3D1826
Triple drawer
CUT-OUT: 17 1/4" x 24 1/2" x 17 1/2"



RF20D-A
50L refrigerator
CUT-OUT: 21" x 19" x 19"



RF40D
Double door
CUT-OUT: 21" x 33 1/2" x 21"



DIC32
Drop in bar chest
CUT-OUT: 28 3/4" x 9 1/2" x 22 1/2"



BCDI-2418
Drop in ice chest
CUT-OUT: 23 1/4" x 12 1/8" x 17 1/4"



T- connector&hose



LP Regulator & hose



Natural connector & hose

Manufactured by: Broilchef Premium