

This Owner's Manual is provided and hosted by [Appliance Factory Parts](#).



Bonaire B18-B36 Owner's Manual

[Shop genuine replacement parts for Bonaire B18-B36](#)



[Find Your Bonaire Evaporative Cooler Parts - Select From 13 Models](#)

----- Manual continues below -----

BONAIRE B SERIES
Commercial Evaporative
Air Conditioning
Bonaire B18 –B36

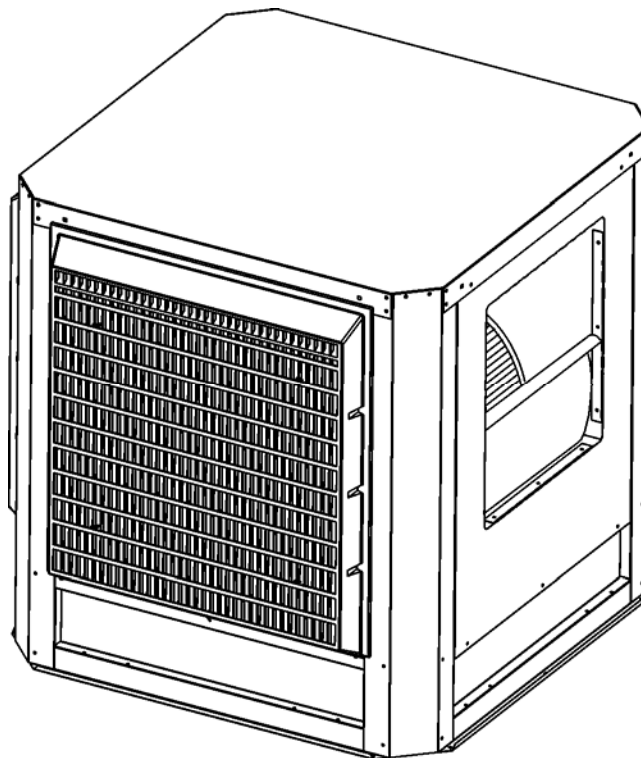

• IMPORTANT NOTICE •

Please leave this manual with the owner of this air conditioner.

Please keep this important manual in a safe place. It is the owner's responsibility to ensure that regular servicing as per the Bonaire Evaporative Air Conditioner service recording planner is carried out. Failure to complete and record the periodic service work as outlined will void all guarantees beyond statutory and legal requirements.



Table of Contents

INTRODUCTION	3
Dealer Responsibility	3
Before Commencing	3
UNIT INSTALLATION	4
Unit Location Check List	4
Precautions	4
Location and Orientation	4
Duct Connection Details	5
Lifting the Unit	6
Mounting the Air Conditioner	6
Ductwork System	7
WATER CONNECTIONS	8
Unit Base Layout	8
Water Installation	10
<i>Connecting the Water Supply</i>	10
<i>Drain</i>	11
ELECTRICAL CONNECTIONS	12
Wiring Connections	12
Wiring – Important Notes	12
Wiring Diagram	13
COMMISSIONING	16
Water Levels	16
Bleed-off Rate	16
Distribution Flow	16
Fan Operation	17
Controls	17
Customer hand Over	17
Commissioning Check List	18
<i>Unit</i>	18
<i>Ductwork and general</i>	18
<i>Site</i>	18
<i>Customer Hand Over</i>	18
OPERATING INSTRUCTIONS	19
WARRANTY – AUSTRALIA ONLY	21
SERVICE & MAINTENANCE	25



Introduction

Please take the time to fully read this Installation manual. Failure to follow these instructions may result in injury to you and damage to the air conditioner or your customer's property.

Installation of this Bonaire Evaporative Air Conditioner must conform to local building rules and regulations, electrical and plumbing codes, Environmental Protection Authority (EPA) regulations, and all applicable Australian Standards.

Should you not follow these instructions the unit warranty may be void. The cost of warranty would then be a cost to the customer or the installer / dealer.

Refer to the tick box Commissioning Checklist to ensure you have covered all points when the installation is complete.

DEALER RESPONSIBILITY

Training

- It is the responsibility of all dealers to adequately train their staff to ensure the product is correctly sized and specified.
- It is the responsibility of all dealers to ensure their installation teams / sub-contractors are trained in the correct installation techniques of both the product and the ducting.
- Climate Technologies will provide technical assistance and training to the dealer / installer. Ongoing training and professional development for staff and contractors is the responsibility of the dealer.

Legal & Statutory obligations

- It is the dealer / installer responsibility to comply with all codes, statutory and legal requirements, state and council / shire by laws.

Safety and O.H.&S. Requirements

- It is the responsibility of the dealer / installer to insure the environment is safe for the installer to carry out the installation.
- It is the responsibility of the dealer / installer to ensure safe access to the unit can be achieved for service.
- It is the responsibility of the dealer / installer to ensure the roof is provided with access footings and platform where the pitch of the roof is greater than acceptable standards
- It is the responsibility of the dealer / installer to ensure tethered restraint anchor points are provided. See Australian Standard 1891.4:2000 Part 4 Selection use and maintenance, Table 2.1.

BEFORE COMMENCING

- Packaging – check there is no damage before removing packaging.
 - Have you got all the system components?
 - Have you got the right unit?
 - Is the System Design Correct?
-



Unit Installation

UNIT LOCATION CHECK LIST

- Place the unit well away from sources of smoke, dust and objectionable fumes so that only clean, fresh outside air will be drawn into the unit. (Refer AS1668)
- Check the proposed location to ensure that building members are structurally capable of supporting the operating weight of the air conditioner.
- Provide easy access to the unit(s) for service. It is the responsibility of the dealer / installer to ensure safe access to the unit can be obtained for servicing.
- Access to the unit and platform / safe roof area must be provided for safe service.
- NOTE: The manufacturer and its agents reserve the right to refuse service unless safety and accessibility to the unit can be guaranteed.
- The cost of any extra equipment required to provide access to the unit for servicing is the responsibility of the owner.

EPA

Any issues with noise abidance on an installation that contravene local council or EPA requirements will be the responsibility of the dealer / installer.

PRECAUTIONS

Please read this manual thoroughly as failure to do so could result in injury to you or damage to the air conditioner and property.

Installation of the air conditioner must conform to local electrical, water supply and environmental codes, rules and regulations and to applicable National Standards.

LOCATION AND ORIENTATION

Check the proposed unit location first to ensure that it is structurally capable of supporting the weight of the unit. A level stand is required which must be capable of supporting the operating weight of the unit, including wind loading. Check the technical data for operating weight.

The preferred location for an evaporative air conditioner on a sloping or pitched roof is on the side from which the prevailing winds come in the summer season.

Always locate the unit where it will receive a plentiful supply of fresh air and not in a recess where it may be starved or where the air is polluted.

Keep the unit well away from exhaust fans and ducts. Never undersize the duct system.

Allow adequate access around the unit for maintenance. Provision must be made for access to electricity, water supply and drains. High roofs need to be provided with permanent access to carry out maintenance or warranty work.

NOTE: It is the owner's responsibility to provide safe access to the unit. Climate Technologies may refuse to do maintenance or warranty work if access is unsafe. If any additional equipment is needed to provide access to the unit, this will be provided (and paid for) by the owner.



Unit Installation

DUCT CONNECTION DETAILS

B18

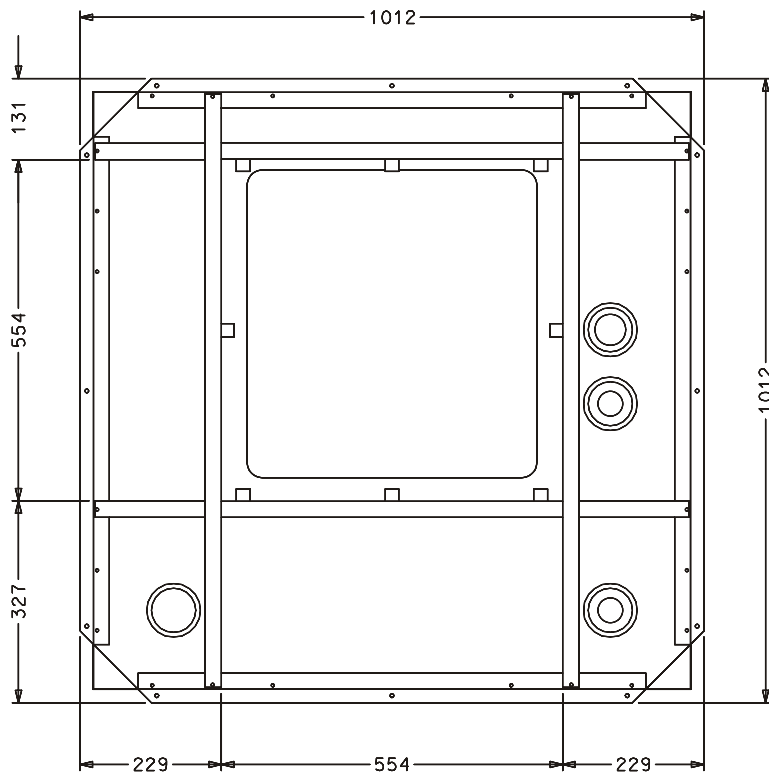

B23 - 36

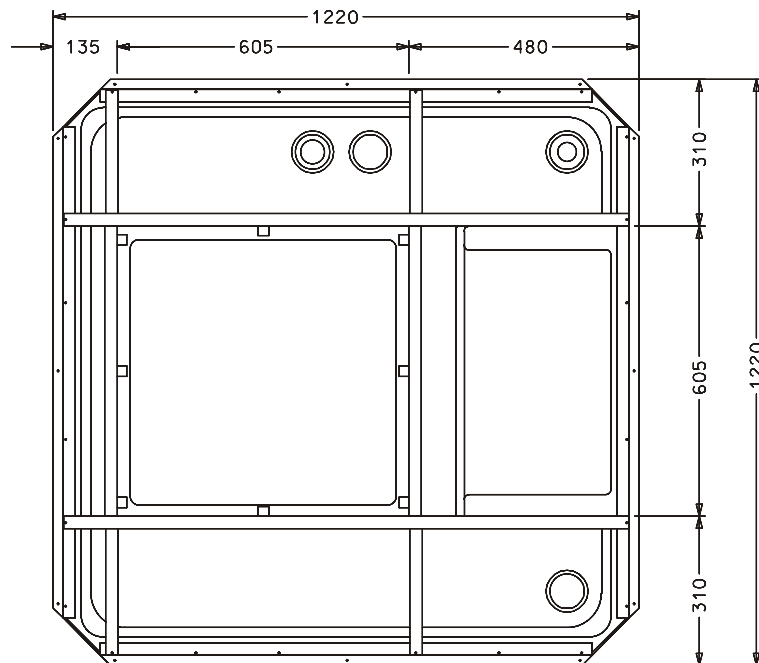

Unit Installation

LIFTING THE UNIT

When lifting the units with a crane, sling the units from the base. Always correctly secure the product in the sling.

Where lifting with a forklift, ensure the lifting tines are long enough to reach right through the bottom of the unit pallet. Extension fork tines may be required. Should you fail to do so, the water reservoir may get damaged.

MOUNTING THE AIR CONDITIONER

1. A mounting stand must be provided with each unit installed.
2. The stand must be designed to carry the operating weight of the product. Where the units are fitted on a roof, ensure the stand is installed on a structurally sound section.

All installations must comply with the relevant building codes, regulations and engineering specifications for the building.

3. An insulator should be installed between the unit base and stand to eliminate and possible reaction between the metal stand and the aluminium chassis.
4. Always ensure the unit is level.
5. Allow adequate access around the unit for maintenance. Provision must be made for access to electricity, water supply and drains. High roofs need to be provided with permanent access to carry out maintenance or warranty work. It is the owner's responsibility to provide safe access to the unit. Climate Technologies may refuse to do maintenance or warranty work if access is unsafe. If any additional equipment is needed to provide access to the unit, this must be provided (and paid for) by the owner.
6. Down Discharge, Side Discharge and Top Discharge units should have a minimum of 300mm from base of unit to bottom / ground level for connecting plumbing.
7. Unit installation should have a minimum of 750mm clearance on all the service sides.

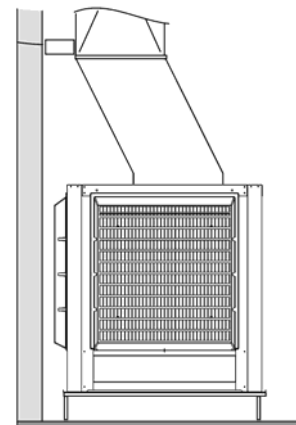
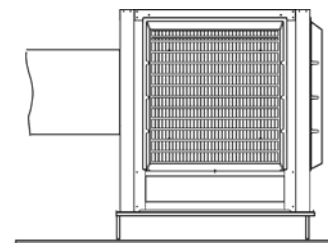
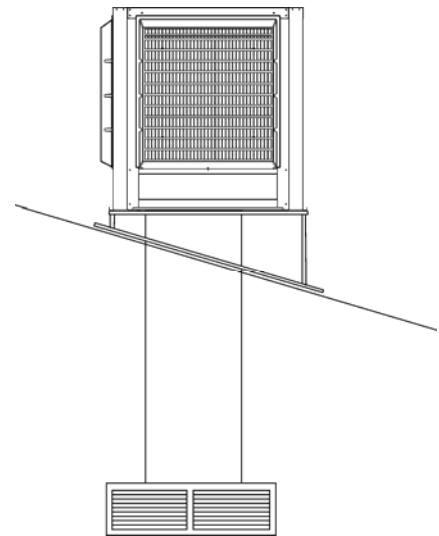



Unit Installation

DUCTWORK SYSTEM

It is essential that water cannot enter the building as a result of inadequate sealing (caulking or flashing) of the fixings, the ductwork system, system pipes and wiring.

All duct designs and airflows must be calculated by a qualified air conditioning consultant or contractor in accordance with normal good ducting practices.

Discharge duct design critical to the air performance of the product. See diagram below.

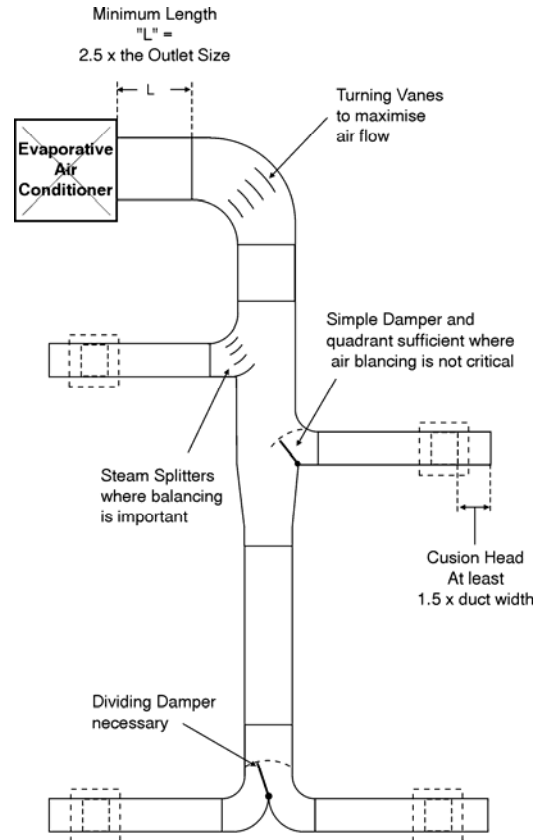
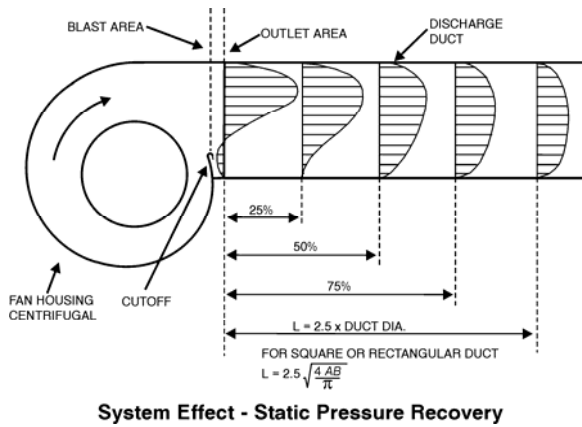

Where flexible ductwork is used, all bends must have a minimum radius of 1.5 times the diameter. All joins must be taped airtight.

The last bend to each ceiling register must be a smooth radius so that airflow is even into the room.

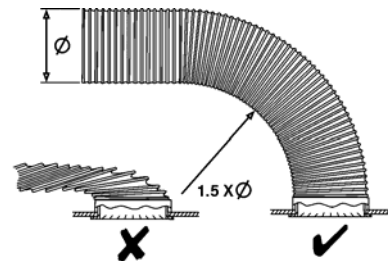



Water Connections

UNIT BASE LAYOUT

B18

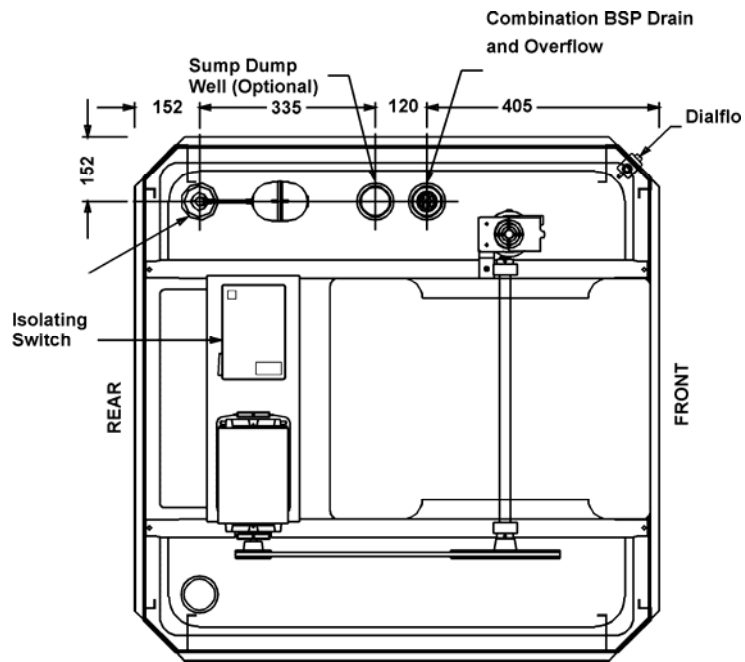

B23

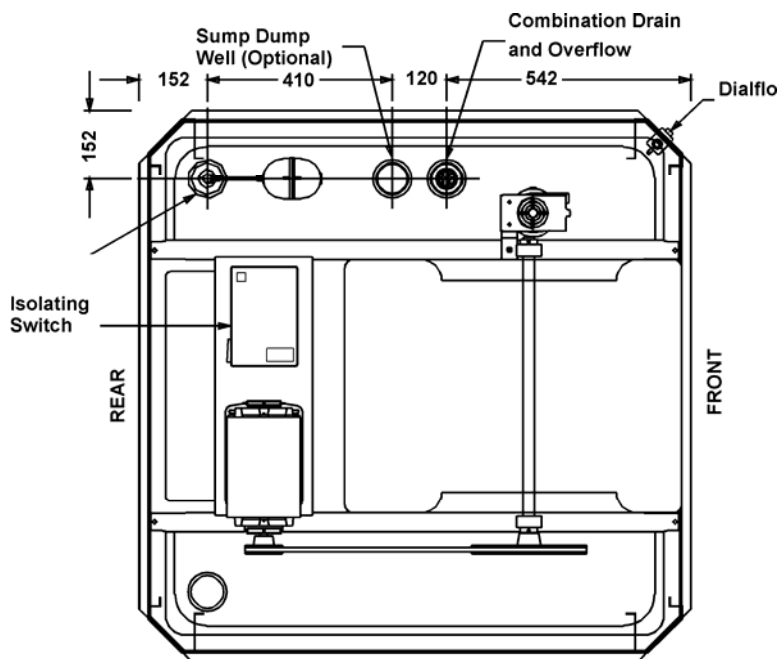



Water Connections

B33

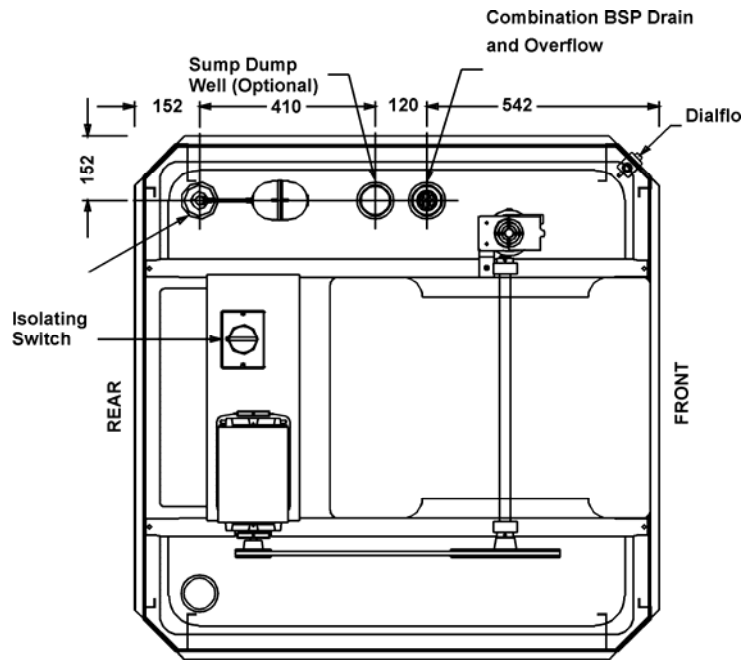

B36

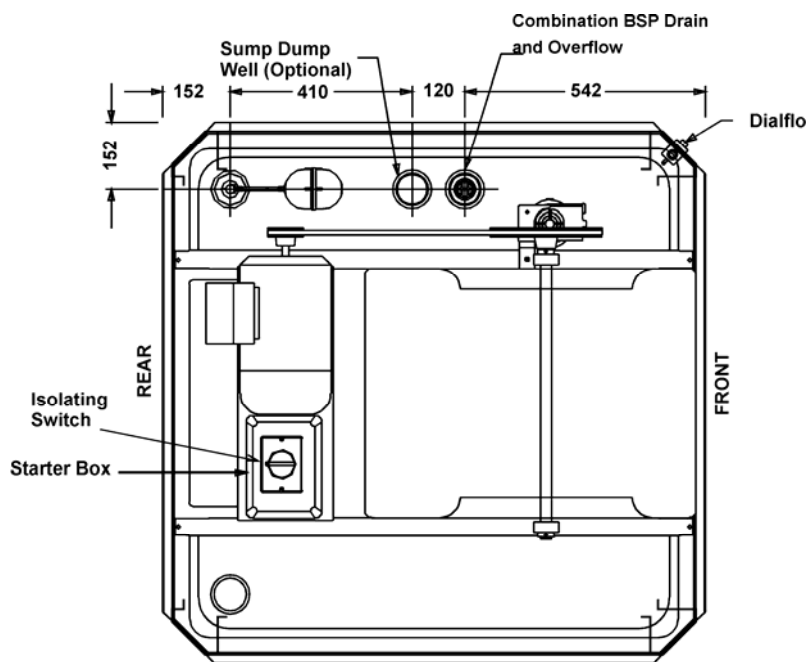

Water Connections

WATER INSTALLATION

A permanent water supply is required to be connected to the unit. Units have been type test certified to MP52, Spec101. Certificate No.8663.

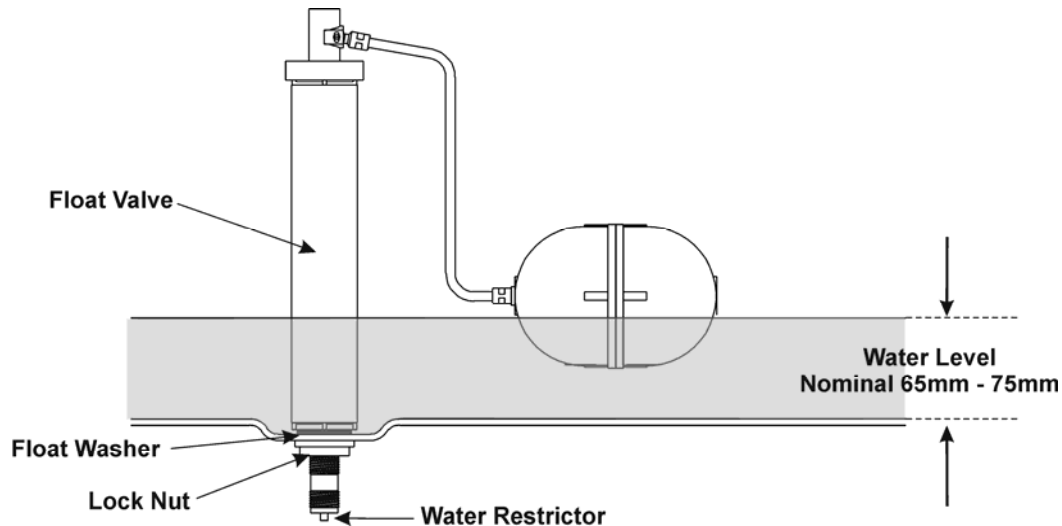

Connecting the Water Supply

- The water supply pipe work and connection to the air conditioner must be installed by a licensed plumber and conform to AS 3500, state & local plumbing regulations.
- Ensure water pressure to the appliance does not exceed the maximum static pressure of 500kPa (50 m head) as per AS 3500 (section 3.3)
- The ball valve connection is inside the unit. Ensure the copper inlet pipe is secured to prevent movement of the float valve.
- The supply pipe should be 12mm copper pipe or similar approved. A ¼ turn ball isolating valve must be installed on the supply pipe near the unit for ease of maintenance. Do not use duo or non-return valves of any kind including stop taps with jumper washer.

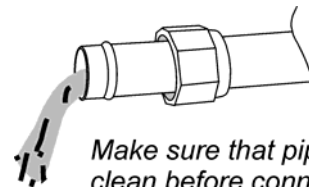

Make sure that pipework is clean before connecting.

NOTE: Non return type valves can have an effect on the operation of the water solenoid valves. Lock up and damage can be caused.

- Fit water supply tap close to the unit to assist in routine servicing.
- Before connecting the supply pipe flush it of any swarf or debris that may cause the float valve to leak.

NOTE: In areas where water pipes freeze, provisions will be needed to drain the water piping to prevent damage to the air conditioner.



Water Connections

Dump Valve (Optional)

- To fit a dump valve a 40mm hole will be required in the lowest section of the tank using the optional sump dump well.

Note:- the overflow assembly is still required.

- Where a Dump Valve is to be fitted, the solenoid **MUST** be installed in series on the unit side of the water-isolating tap.
- Fit the black pressure tube between the dump valve and the solenoid valve.
- The 24V solenoid will be supplied with an in-line transformer for 240V connection.
- Connect the 240V solenoid transformer leads in parallel with the pump terminations.

Or

Connect to a timed / delay independent circuit supplied by the installer.

- The tank in the unit will only fill once power has been applied to the solenoid valve transformer via the pump or an alternate dump timing circuit. The water pressure through the black tube then closes the dump valve.

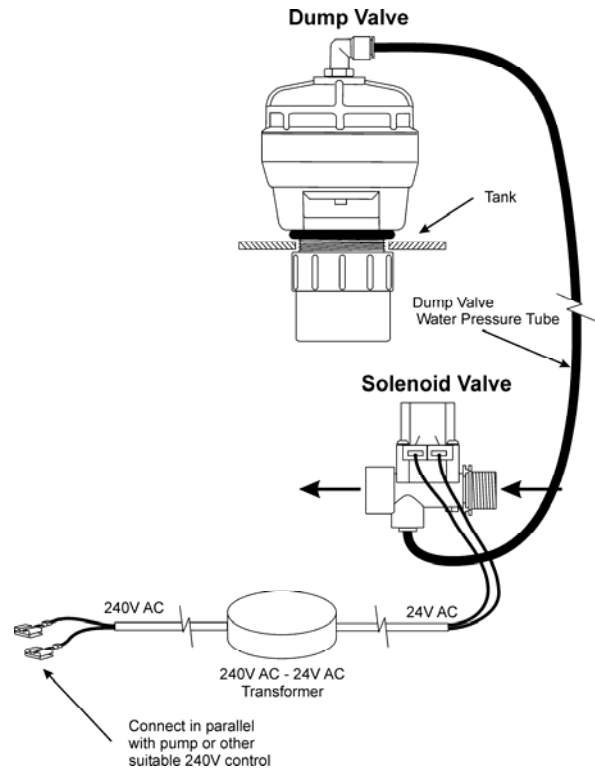

Drain

The combination drain/overflow pipe outlet must be connected to a drainpipe, which has sufficient capacity to take the discharge of water from the reservoir. The pipe must connect to a suitable drain or gutter.

Note: Refer to local regulations to ensure discharge of drain / overflow water is in accordance with statutory requirements.

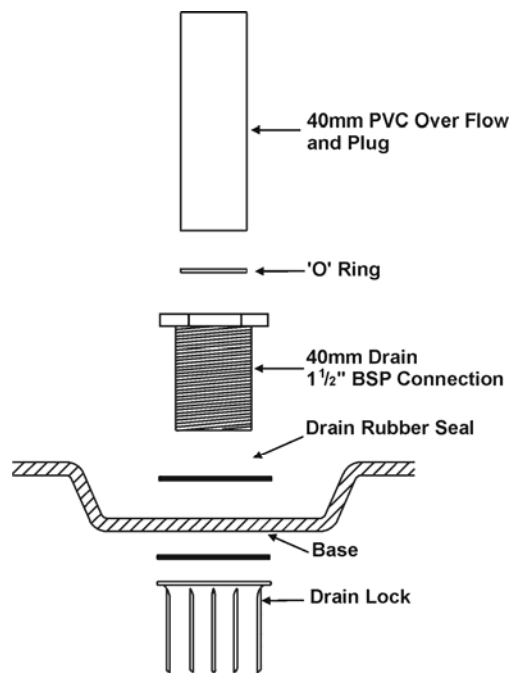



Electrical Connections

WIRING CONNECTIONS

- Have a licensed Electrician install a dedicated circuit from the distribution board with a separate circuit breaker for each unit installed.
- Unit isolating switch is provided on the control box in the unit.

Isolate the mains supply at the circuit breaker before conducting any electrical connect work.

- Circuit breaker selection and cable size must be made relevant to the current rating of the motor and the circuit breaker motor Kw specifications.
- Where 3 phase units are being with frequently stop / started on high speed, a delay timer must be fitted to the low speed control circuit by the installer to start the unit on the low speed. This will reduce the level of maintenance required to belts and pulleys.
- Electrical connections must be easily accessible for service and maintenance.
- Check to see if the voltage of the air conditioner is compatible with your electrical system voltage. Check that there will not be excessive voltage drop, which will cause the unit to run inefficiently or even cause motor burn out. $\pm 5\%$ of the motor nameplate voltage is usually acceptable by motor manufacturers.
- Prior to completing the installation an electrician must check that the air conditioner is operating correctly, and that the fan is rotating in the correct direction.
- Replace all lids and covers.
- The manufacturer advises that they will not be held responsible for replacement of parts or labour costs on electrical components which fail as a result of incorrect wiring.

WIRING – IMPORTANT NOTES

- **A LICENSED ELECTRICIAN must carry out all electrical connection wiring to the unit. It is the responsibility of the LICENSED ELECTRICIAN that the unit is connected as per AS3000 (Wiring rules) and any local regulations and statutory or legal requirements.**
- **Where 3 phase units are clustered using a single wall control for multiple units, the unit control box must labelled indicating live wires inside. There will be voltage in the control circuit if all units in the cluster are not isolated in the multiple connections.**



Electrical Connections

WIRING DIAGRAM

Single Phase B18, B23

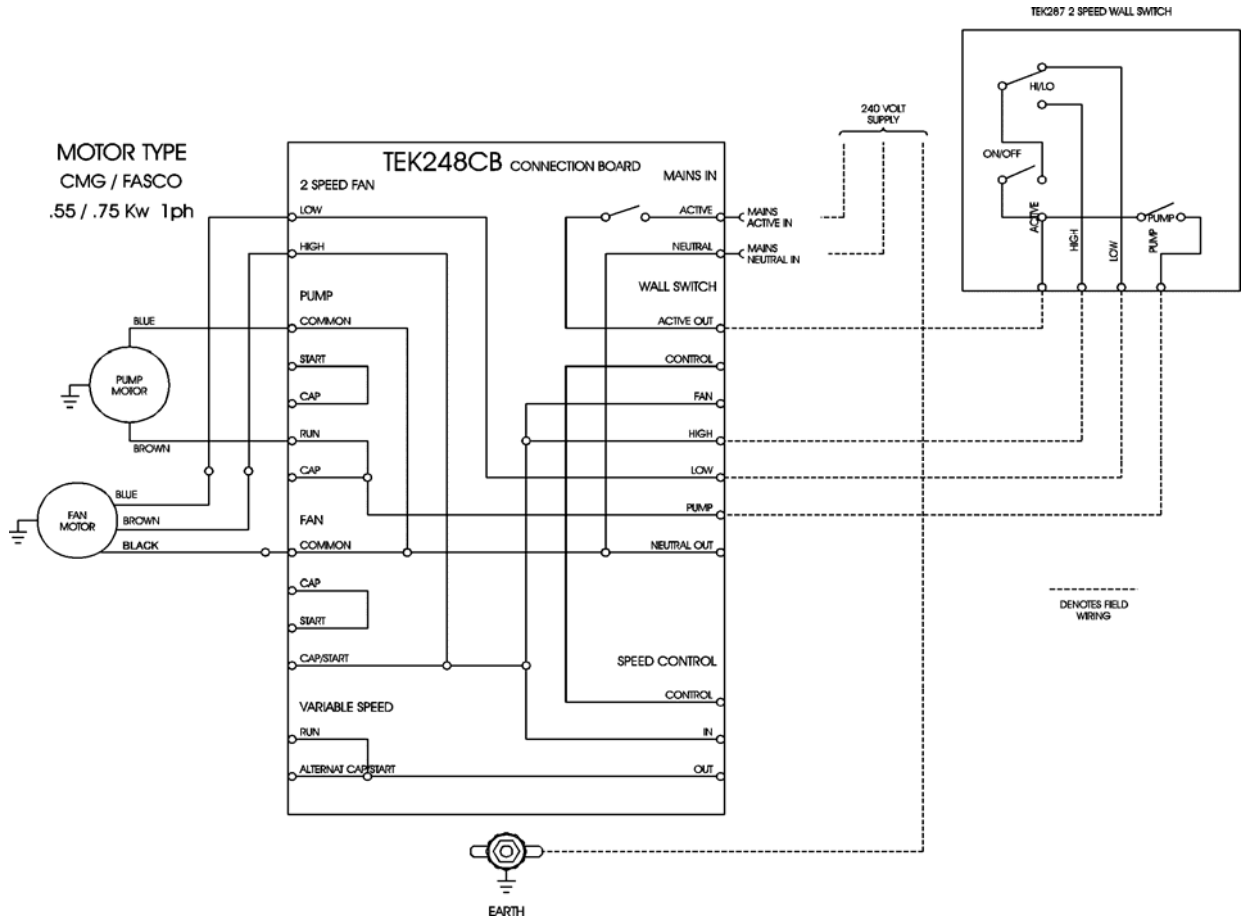

Single Phase B33

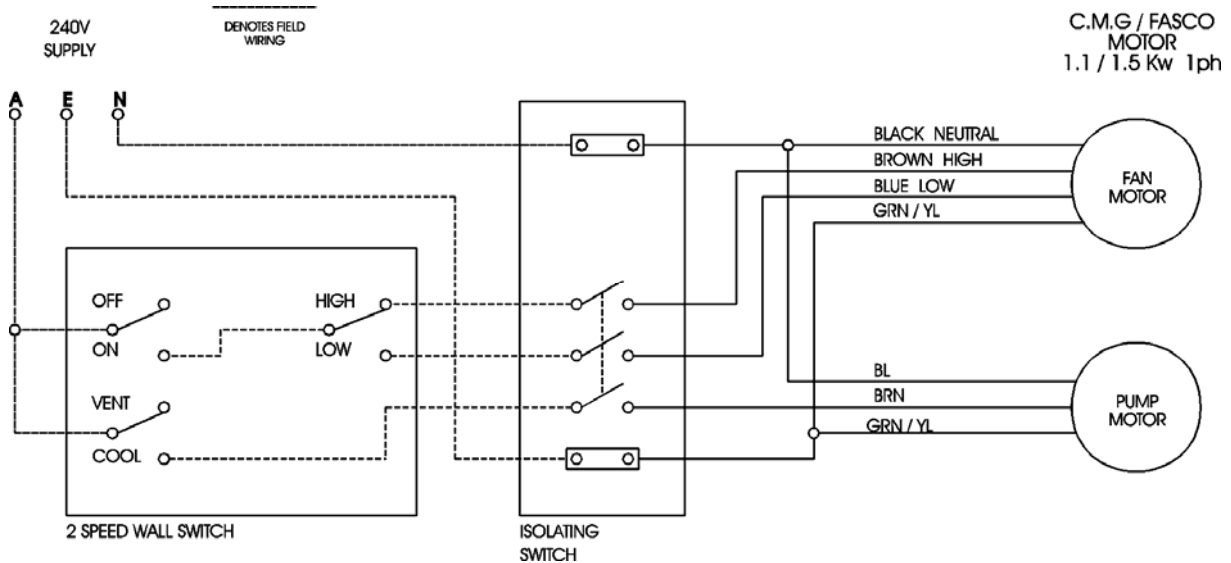



Electrical Connections

Three Phase B36

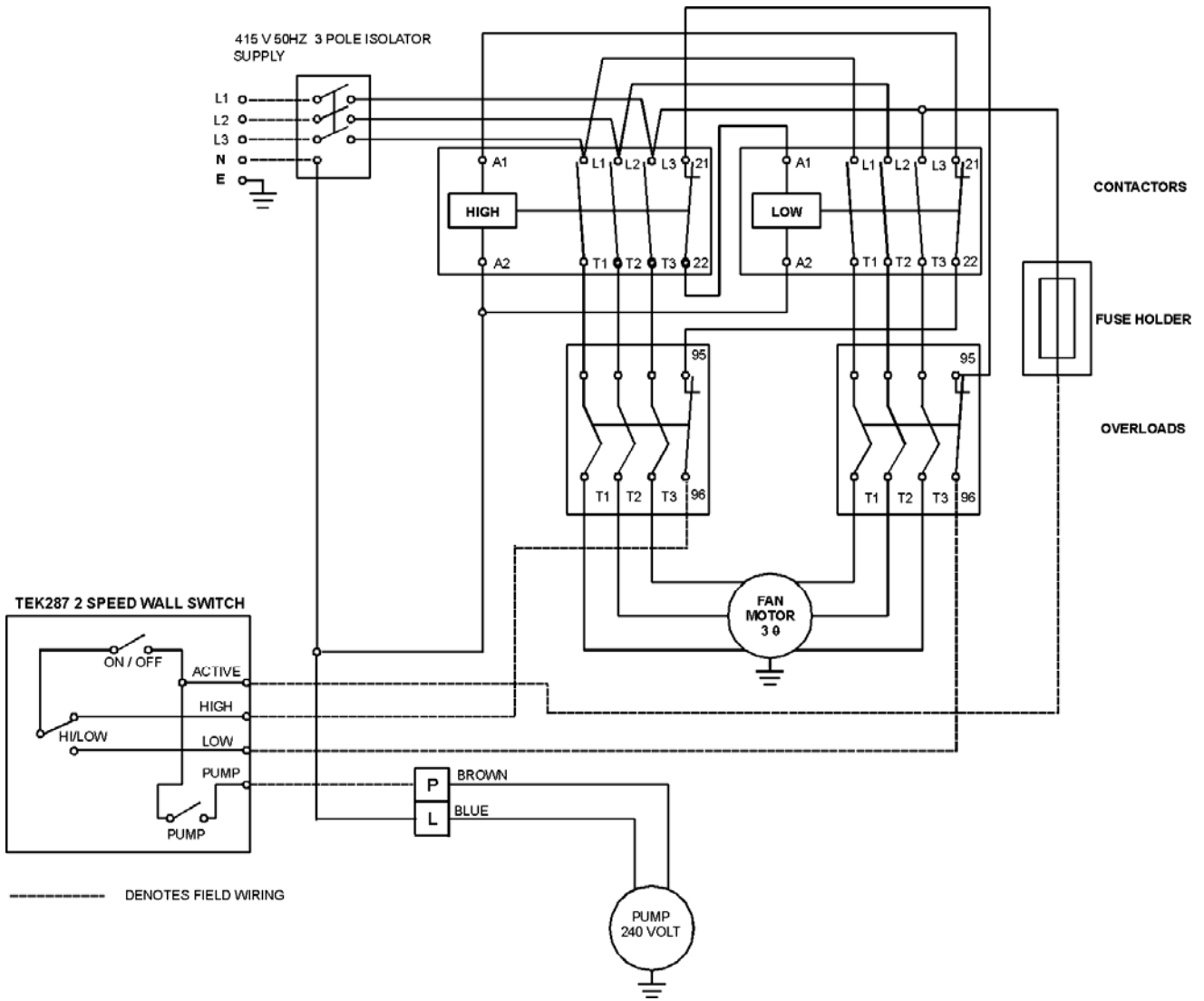



Electrical Connections

Variable Speed

Single Phase B18, B23

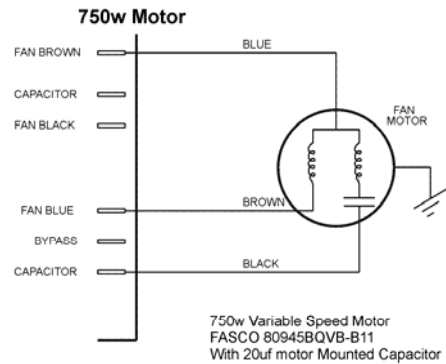
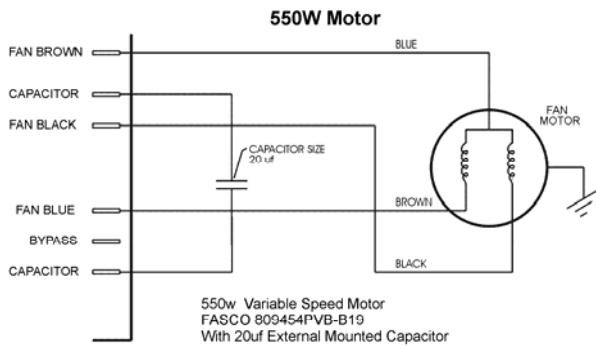
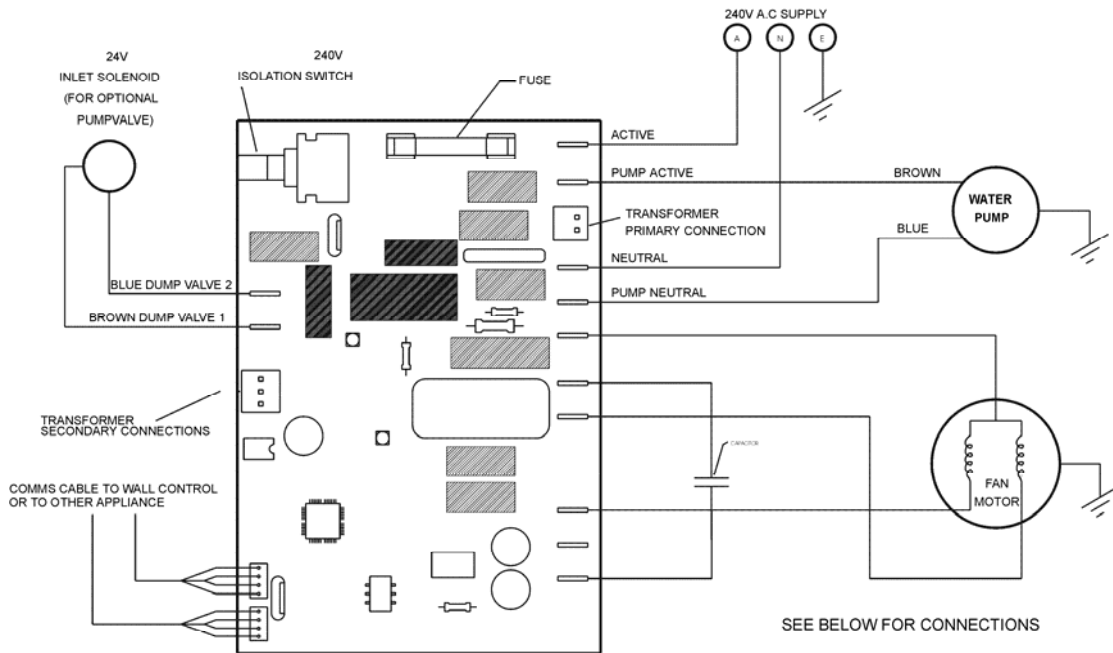

Commissioning

WATER LEVELS

- Turn water on to unit and allow the reservoir to fill. The water should be 65mm to 70mm from the bottom of the tank.
- If a dump valve is fitted, turn the pump (or dump circuit) on to activate the solenoid. Water pressure will be applied to the dump valve plunger via the black pressure pipe, cause it to close allowing the reservoir to fill.
 Note: the dump valve has minimum and maximum operational pressures of 100 kPa to 1000kPa. Where pressures are below 100 kPa, the dump valve may not close and the reservoir will not fill.
- Adjust float valve arm as required to set the water level (65 – 70mm).
- Fit Louvre panels and check for even wetting of the filter medium

BLEED-OFF RATE

- All evaporative air conditioners need some water bleed-off to prevent build-up of mineral deposits in the system. The correct setting of the bleed rate will ultimately govern the life of the unit.
- Recommended bleed rates should be set at approximately 5 litres per hour per 1000 litres of air. Increased water hardness will require a higher bleed rate and increased maintenance.
- It is recommended to plumb the bleed off hose through the overflow fitting and the bleed-off away to a downpipe in situations where the discharge may cause unsightly stains.
- To control the bleed-off rate rotate the bleed dial clockwise for more water and anti-clockwise for less water.

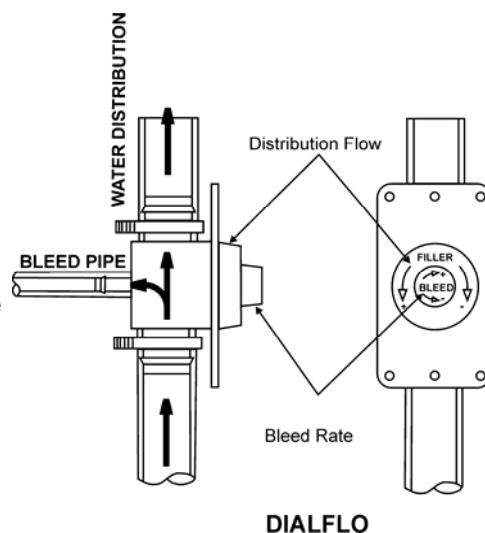

NOTE: It is the responsibility of the installer to set a correct bleed rate to suit local conditions.

- If a dump valve is fitted and is set up for regular timed dumping periods during operation, the bleed may not need to be set subject to water quality.
- If a dump valve is fitted and is only to be used for the purpose of a dry sump when not in use, the bleed rate will have to be set for normal operation.

DISTRIBUTION FLOW

Generally the flow rate to the water distributors will be set to full. However there will be some circumstances where water carry-over may occur. To stop water carry over where there appears to be an excess of water on the filters, adjust the outer knob of the Dialflo to clockwise to reduce the amount of water to the filters.

Note: Hold the bleed knob while adjusting the distribution flow, as this may go out of adjustment when turning the distribution flow knob.



Commissioning

FAN OPERATION

- Check that pulleys are correctly aligned.
- Check the belt tension is correct. Nominally 15 – 20mm depression.
- Check bearings are tight on shaft
- Set the fan running and check.
- Check that the air is being evenly distributed through the ductwork.
- Make adjustments, as required, to any manual air dampers that may be fitted.
- **Fan Motor Current.** Check the motor operating current is not greater the rating plate value.

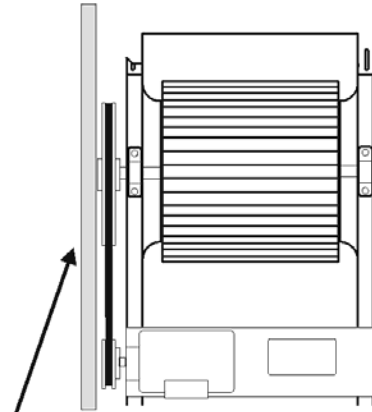

Straight Edge for pulley alignment

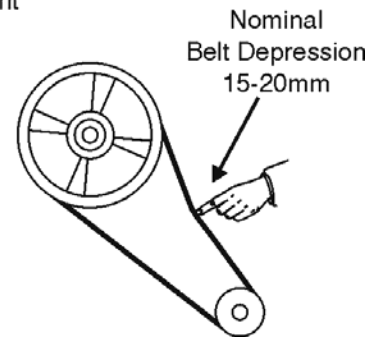

Nominal Belt Depression 15-20mm



- For systems with high statics and non standard drive check motor current. Where required, review pulley requirements relative to the system static. Where variable pitch pulleys are fitted adjust accordingly.
- For systems with minimal static eg straight dropper and plenums, check motor current. A smaller motor pulley to standard may be required.

CONTROLS

Check all control functions are working

CUSTOMER HAND OVER

Instruct the customer in the use of the product.

- Controls
- Bleed off
- Venting the air via the side of the premises the wind is not blowing from.
- Maintenance Requirements

Hand over of the customer’s operational manual.



Commissioning

COMMISSIONING CHECK LIST

You must complete, date and sign the 'tick box' checklist in the owner's warranty card. Use this copy to check the installation prior to completing the owner's documentation.

Unit

- All equipment ordered by the customer is installed.
- The unit is level and secure.
- The water supply line has been flushed to clear swarf and debris and is free of leaks.
- The tank is free of foreign matter and debris and the water isolating tap is turned ON.
- Water drainpipe work is completed and sealed.
- The water basin fills with water and the float valve closes correctly when the water level is 65 -70mm from the bottom of the tank.
- The water pump(s) operates correctly when turned ON at the controller.
- The Dialflo water bleed rate is adjusted to suit local water conditions.
- The Dump Valve (option). The tank drains correctly when unit turns off.
- The fan deck is correctly located and the fan blade spins freely.
- The mains and control wiring are complete and the circuit breaker is turned ON.
- The fan operates correctly on all speeds.
- Water distribution is even with the filter pads fitted and the air conditioner operating pump and fan.

- All Controller functions for the appliance operate.
- Fan motor current draw.

Ductwork and general

- All ductwork is completed to plan, correctly supported and airtight.
- Air distribution checked, dampers are adjusted and all outlets correctly adjusted and wiped clean.
- All roof penetrations are fully sealed and watertight.
- Man-hole cover replaced.

Site

- All rubbish has been removed from inside and on the roof.

Customer Hand Over

You have explained the following to the customer.

- The operation of the Controller.
- Adequate exhaust is required for the effective cooling. Air exit areas should be at least 0.5 square meters per 1000 litres of air.
- The operation of the bleed or dumping system and it's importance to operate all the time
- Maintenance requirements

Operating Instructions

USING YOUR AIR CONDITIONER

The principal of your unit is to introduce fresh air, which is washed through the filter pads to provide cool fresh air. The air is exhausted taking with it any heat loading on the space. Evaporative Air Conditioners must always function on 100% fresh outside air.

Exhaust / Air Relief

Evaporative air conditioners require you to open or provide exhaust outlets in the space being cooled. Such outlets may be provided by the opening of doors and/or windows in various rooms or sections. They may also be provided by the installation of special exhaust grilles through doors, walls or into the ceiling (attic) space of the building. Air exit areas should be at least 0.5 square meters per 1000 litres of air.

Where the building does not allow such easy exhaust provisions, there must be some kind of mechanical ventilation installed, such as an exhaust fan which can extract approximately 80% of the air that the air conditioner is discharging.

Never allow conditioned air to exhaust into a closed space, it must always be allowed to exhaust to the outside.

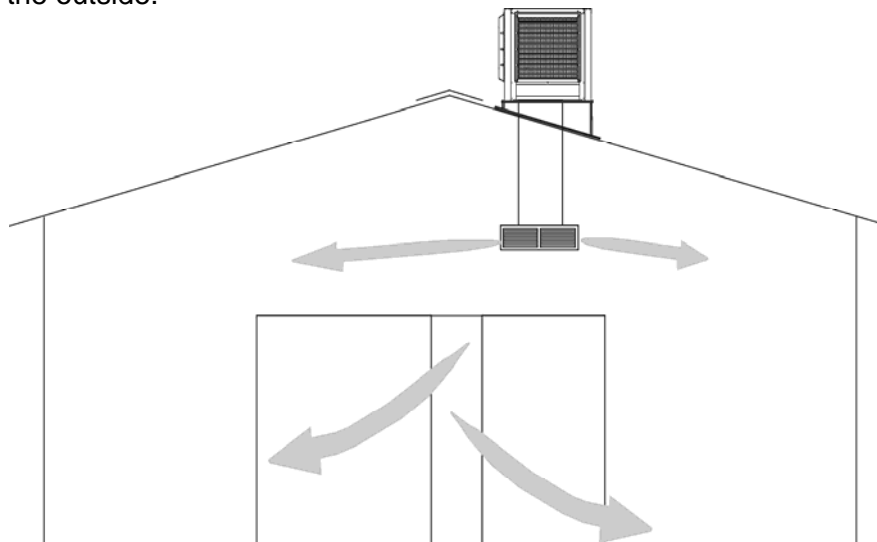

When deciding on an exhaust point using doors, windows or louvred vents, always keep the opening options closed on the windward side of the building.

General Operation

Generally, the higher the relative humidity, the higher the air quantity required from the air conditioner. You should therefore control the speed of your air conditioner accordingly. On very dry days the air conditioner will give maximum cooling and this will decrease as the humidity increases.

The air distribution system in your building has been fitted with air outlet grilles and they probably have adjustable louvre blades. You can adjust the blades yourself to create your own pattern of air distribution in the space.

If you close the louvres too much you may get undesirable air noise.



Operating Instructions

OPERATING INSTRUCTIONS – 2 SPEED CONTROLS

Turn on the water supply at the source and make sure that the water isolation valve at the unit is also turned on.

Turn on the electrical power at the source and make sure that the isolating switch in the unit is turned on.

Cool / Pump Operation

Turn COOL switch on.

It is recommended that you wait 10 minutes for the pump to saturate the filter pads. A longer period may be required where a dump valve is fitted.

Fan Operation

Select LOW fan speed, using the switch on the control panel inside the building, then switch unit ON. (It is recommended to start the unit on LOW speed, and then switch to HIGH if required).

At times, when the outside humidity is very high, you may feel more comfortable using ventilation system only. For ventilation system only, turn the COOL switch off and run the fan only. The fan speed can be selected as described above.

Follow the above instructions about providing exhaust opening in the building. This is very important. When unit is turned OFF the COOL switch should also be turned OFF as the pump is independently switched.

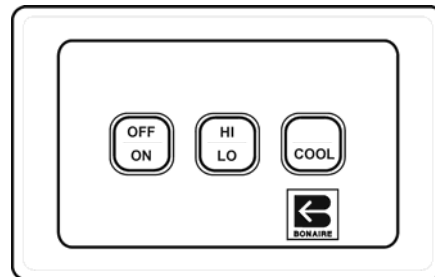
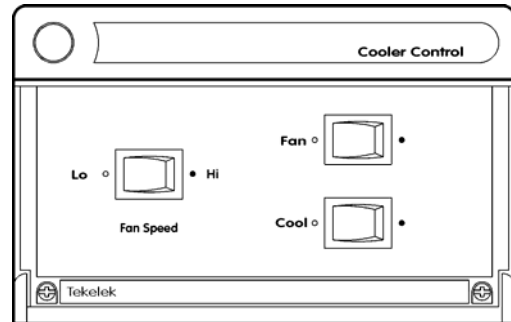

OPERATING INSTRUCTIONS – OPTIONAL VARIABLE SPEED CONTROLS

For variable speed motors, refer to the owners manual supplied for unit operation details.



Warranty – Australia Only

IMPORTANT:

Please read this warranty information and complete the Dealer/Product information on the following page. KEEP this with your original purchase documents for any claim under warranty.

WARRANTY PROCEDURES:

Firstly refer to your owners manual to ensure you have followed the correct operating procedures of your product, and refer to the trouble shooting guide to assist solving any problems you may have.

1. Read this warranty statement carefully before you request warranty service as items relation to installation are not covered by this appliance warranty.
2. A proof of product purchase must be provided for warranty service, to validate the appliance is within the manufacturer's warranty periods.
3. This warranty is only for products and associated original controls for Climate Technologies manufactured product.
4. Only an authorised Climate Technologies service provider must carry out warranty service.
5. Statutory warranty is 12 months from date of purchase and all additional periods are classified as manufacturer's voluntary warranty.

Climate Technologies provides the following Manufacturers warranty on new product additional to all implied warranties and other statutory rights which you may have under the Trade Practices Act and similar State & Territory Laws, subject to the following terms and conditions.

TERMS AND CONDITIONS:

Conditions to warranty

- Subject to the exclusions noted, Climate Technologies warrant the product for the period as prescribed in the table following this statement to be free from Inherent defects in materials and workmanship for functional and structural components.
- This product is only valid if the product is operated in accordance with the manufacturers instructions
- The appliance must not be modified or changed in any way.
- Your proof of purchase MUST be produced before free service will be provided.
- Travelling time and mileage are included within 30km of either your authorised Climate Technologies dealer or service provider's premises. Customers in areas other than the above are responsible for any travelling time and mileage required to carry out warranty repairs.
- The product must be installed by a qualified person in the manner prescribed by local & statutory regulations and to the manufacturer's specifications.
- Service within the terms of this warranty will be recognised where we are satisfied that the appliance or part was supplied within the relevant time limits. Documents of purchase and Dealer/Installer information will assist in this process.
- Product fitness for purpose and overall system design / sizing is solely the responsibility of the dealer / installer. This includes but is not limited to heat load calculations, air flow, system balancing, humidity, water quality etc.
- The product must be installed in an easily and safe accessible area for service, appliances installed in areas not easily and safely assessable, costs will be borne by the owner for access equipment should maintenance be required.



Warranty – Australia Only

DIY installation Warranty

- If the product has been installed as a DIY, a supply part only warranty will apply. Parts only will be supplied free of charge on the return of the faulty part and the owner will be responsible for all labour charges incurred for the part to be fitted by a qualified person. Labour warranty as prescribed in the following table is void in this situation.

Remote Location Warranty

- If the product has been installed outside the Climate Technologies service network, a supply part only warranty will apply. Parts only will be supplied free of charge on the return of the faulty part and the owner will be responsible for all labour charges incurred for the part to be fitted by a qualified person. Labour warranty as prescribed in the following table is void in this situation.

Exclusions to warranty.

- Consumable items subject to wear and tear such as filter pads, drive belts and bearings are not covered by this warranty.
- Components used as part of the installation such as grilles filters, ducting, fittings, zone motors and consumer services pipe work are warranted from your place of purchase and not covered by this warranty.
- Damage caused by elements such as wind, rain, lightning, floods etc along with power spiking and brownouts are not considered defective material or workmanship and as such are not considered warranty.
- No responsibility will be accepted for outside elements such as pests, animals, pets and vermin that may cause damage to the unit.
- Harsh environmental situations such as salt air that may cause cabinet damage / rusting can not be considered warranty.
- The manufacturer does not accept liability or any claims for damage to building contents, carpet, walls, ceilings, foundations or any other consequential loss either direct or indirect. Damage resulting from, power spikes, incorrect operation, incorrect installation, incorrect maintenance is also not covered.
- All warranties are NOT transferable.

Conditions where warranty may be void.

- If there is no certificate of compliance for plumbing, electrical or refrigeration as required by State & Territory Laws. Climate Technologies reserves the right to refuse service on non-compliant installations.
- The defective operation of the appliance that is due to failure of electricity, gas, water or refrigerant gas supplied.
- Defects are caused by neglect, incorrect application, abuse or by accidental damage of the appliance.
- An unauthorised person has attempting to repair the appliance.
- A situation arises referenced in the trouble-shooting guide.
- A charge will be made for work done or a service call where there is nothing wrong with the appliance.



Warranty – Australia Only

PROOF OF PURCHASE

It is important that the name of the Dealer or Retailer from whom you purchased your product and the name of the installer are recorded on this page. The installer is responsible for the correct installation, start up and demonstrating the operation of this product. The Dealer or retailer is also responsible for issuing the relevant certificates of compliance for the electrical connections. (These may differ from state to state)

Please attach your proof of purchase here. Your receipt is your warranty and will be required to validate any warranty.

DEALER PRODUCT INFORMATION:

Dealer/Retailer:	
Dealer Address:	
Dealer Phone Number:	
Unit Model Number:	
Serial No:	
Date Installed:	
Installed by:	
Date Commissioned:	
Commissioned by:	Signature:

PERIODS OF WARRANTY – YEARS BY PRODUCT AND APPLICATION:

Ducted Evaporative Air Conditioning – Commercial / Industrial

Unit Components	Parts	Labour
Corrosion on Cabinet	2	2
Structural Guarantee	2	2
** All other components	2	2

** Consumables e.g. Filter pads, "V" belts and bearings are not covered by this warranty



Warranty – Australia Only

Aged New Product Warranties

For a new product warranty to apply, a product needs to be purchased and installed within 3 years of the manufacturing date by the original purchaser.

Product that is aged as the result of extended storage or being used for demonstration purposes, the following warranty conditions will apply.

- For a product that is greater than 3 years and less than 5 years old from date of manufacture the statutory warranty will apply and any voluntary warranty originally supplied will be reduced by 1 year
- For a product that is greater than 5 years of age from date of manufacture, the statutory warranty will apply to electrically functioning components only. All other components being cabinets, louvres, filters etc. will not be covered by warranty.

WARRANTY ON REPLACEMENT PARTS:

Parts replaced under warranty are warranted for the balance of the original warranty period.

SERVICE CENTRES:

Only qualified service personnel should conduct any service work carried out on your ducted reverse cycle air conditioning system. It is important that periodical service is carried out on your product to ensure you will receive the efficiency benefits the product provides.

For Metro Service only ring the numbers below.

South Australia/ Northern Territory	(08) 8307 5230
New South Wales / Australian Capital Territory	(03) 8795 2457
Western Australia	(08) 9454 1000
Victoria/Tasmania	(03) 8795 2456
Queensland	(03) 8795 2457





Service & Maintenance

PROBLEM SOLVING

PROBLEM	PROBABLE CAUSE	SUGGESTED REMEDY
<p>Inadequate Cooling</p>	<ul style="list-style-type: none"> • Undersized air conditioner. • Clogged or dirty filter pads. • Insufficient air discharge openings or inadequate exhaust from area being cooled, causing high humidity and discomfort. • Excessive Ambient Humidity (see also item above re-inadequate exhaust). • Fan turning backwards. • Fan running too slowly. • Belt slipping. 	<ul style="list-style-type: none"> • Replace with larger air conditioner. • Clean or replace pads. • Check water distribution system for possible obstruction in tubing. Check pump. • On days during summer when the ambient humidity is very high, the air conditioner will not reduce temperature as much as on drier days. There is no remedy except to shut off the pump. • Re-connect motor for correct rotation. • Check motor amps. If below nameplate amperage, re-adjust motor pulley (sheave) to increase fan speed. • Tighten belt by re-adjusting position of motor. Replace belt if worn.
<p>Fan fails to start</p>	<ul style="list-style-type: none"> • Circuit breaker tripped or fuse blown. • Loose electrical connections. • Defective control switch. • Motor burnt out. • Belt or pulley loose. • Belt broken or missing. • Belts too tight. 	<ul style="list-style-type: none"> • Reset circuit breaker or broken fuse. Check circuit breaker size correct • Check all electrical connections. • Replace. • Replace. • Tighten belt and pulleys. • Install new belt • Adjust belt tension.
<p>Belt slipping or wearing excessively</p>	<ul style="list-style-type: none"> • Belt loose. • Pulleys out of line. • Moisture getting on belt. • Worn belts. • Worn pulleys. 	<ul style="list-style-type: none"> • Tighten belt. • Align pulleys. • Stop any water leaks. Adjust Dialflo to stop water carry over. • Replace belt • Replace pulleys.



Service & Maintenance

PROBLEM	PROBABLE CAUSE	SUGGESTED REMEDY
Pump fails to operate	<ul style="list-style-type: none"> • Pump motor failure. • Loose electrical connections. • Pump control switch faulty. 	<ul style="list-style-type: none"> • Replace complete pump. • Tighten electrical connections. • Replace pump control switch.
Pump runs but does not circulate water; Pump runs but pads lack water	<ul style="list-style-type: none"> • Insufficient water in pan. • Pump strainer blocked. • Blocked water in tubing. • Foreign matter lodge in the water distribution piping. 	<ul style="list-style-type: none"> • Adjust float level. • Clean strainer. • Clean the tubing. • Clean out foreign matter.
Noisy air conditioner	<ul style="list-style-type: none"> • Fan rubbing on housing. • Fan out of balance due to dirt, etc. • Air conditioner delivering more air than needed. • Belt 'squealing'. • Inadequately sized ducts or grilles. 	<ul style="list-style-type: none"> • Re-position fan. • Clean fan. • Adjust ducting baffles to reduce airflow or balance flow to outlets. • Tighten belt by adjusting motor. Apply belt dressing to belt. In some cases it may be necessary to replace belt. Check the pulley alignment • Increase size or add additional ducts or grilles.
Continuous overflow of water	<ul style="list-style-type: none"> • Float valve adjustment incorrect. 	<ul style="list-style-type: none"> • Adjust float valve.
Water into the duct work	<ul style="list-style-type: none"> • Loose water tubing connections. • Break in water tubing. • Too much water from the pump 	<ul style="list-style-type: none"> • Tighten all connections. • Replace any cracked or broken tubing. • Adjust the dialflo outer knob to reduce the flow of water to the filter pads.
Unpleasant odour	<ul style="list-style-type: none"> • Air conditioner located near source of unpleasant odour. • Algae in pan water. • Pads remain wet after shut down. 	<ul style="list-style-type: none"> • Remove source of odour or place a barrier between air conditioner and source of odour. • Drain pan and clean thoroughly. Fill with fresh water. Install new pads. • Allow fan to run for about 10 minutes after pump is shut off to dry out pads.
Rapid formation of white deposits	<ul style="list-style-type: none"> • High mineral content of supply water. 	<ul style="list-style-type: none"> • Increase the bleed rate. Fit a dump valve and timer for cyclic dumping.



Service & Maintenance

REGULAR MAINTENANCE

A qualified service technician should conduct any service work carried out on your commercial cooling product. It is important that periodical service is carried out on your product to ensure you will receive the efficiency benefits the product provides.

Note: Local regulations and codes may require the owner to carry out and record specific maintenance in a log book e.g. cleaning and draining the evaporative cooler sump.

Note: Before conducting any electrical maintenance, ensure the power is isolated to the unit at the circuit breaker.

Maintenance

1. Turn off the electric power supply.
2. Turn off water isolation valve.
3. Remove the filter frames and clean filters with water.
4. Replace filter pads where required.

The frequency depends on the daily use of the air conditioner, the state of the environment and the quality of the water. Each of these factors affects the life of the pad.

Please note that the filter pads supplied, being CELdek or wood wool, have been selected to give the highest possible cooling performance. Use only Climate Technologies genuine replacement filters. The manufacturer is not responsible for the performance of the air conditioner when alternative components are used.

Note: Filter pads are a consumable and are therefore not covered by warranty

5. Flush and clean the reservoir.
6. Check the water level and reset the float arm setting if required.
7. Check the pump has free operation and clean the filter basket.
8. Check the fan bearings.
 - Check there is no bearing wear on the shaft and that the bearings are tight on the shaft.
 - The B series units are fitted with sealed bearings. Replace bearings as required.

Note: Bearings are a consumable and are therefore not covered by warranty.

9. Check the fan belt tension and adjust if necessary. To adjust the belts:
 - Remove the belts from the drive.
 - Mark the motor tray location on the chassis.
 - Loosen the motor tray bolts on each side, and slide the tray back in 5mm increments.
 - Tighten the motor tray bolts on each side and refit the vee belts.
 - Check the belt tension and pulley alignment. The belt should only depress approximately 15-20mm in the centre of its span.

Note: Vee belts are a consumable item and are not covered by warranty

10. Once all maintenance has been completed, turn the mains power on and test.



“Excelling today for a better tomorrow”

Manufactured by
Climate Technologies
ABN 13 001 418 042

www.climatetechnologies.com.au