

This Owner's Manual is provided and hosted by [Appliance Factory Parts](#).



Breezair TBS500 Owner's Manual

[Shop genuine replacement parts for Breezair TBS500](#)



[Find Your Breezair Evaporative Cooler Parts - Select From 59 Models](#)

----- Manual continues below -----



INSTALLATION MANUAL

TBQ / TBS Evaporative Cooler

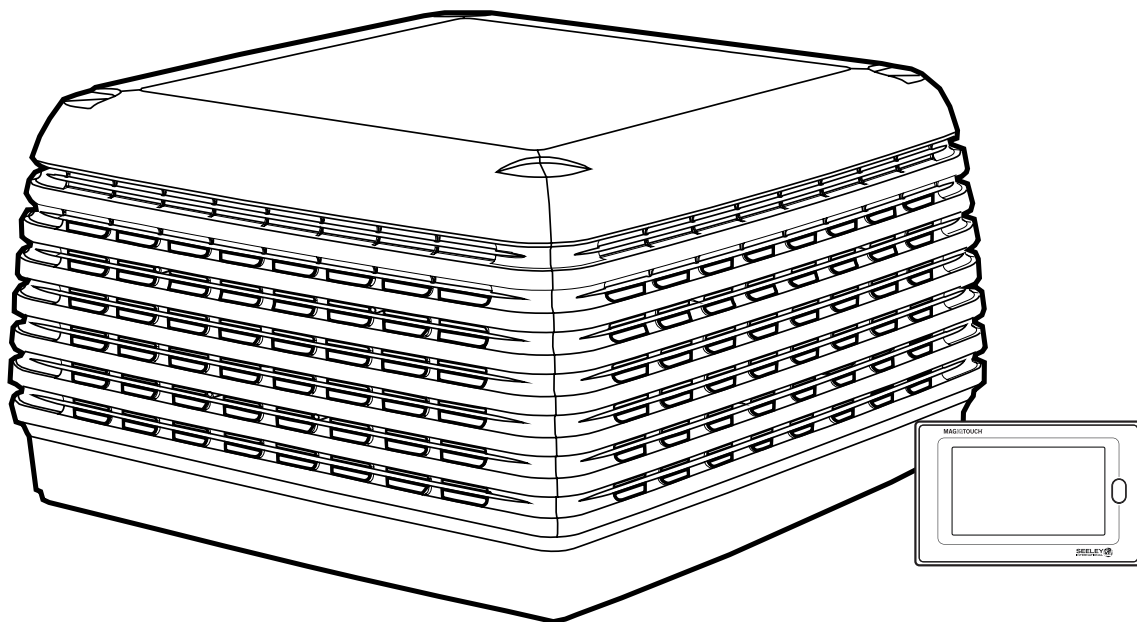

TABLE OF CONTENTS

SAFETY	3
QUICK GUIDE	4
COOLER LOCATION	6
REMOVING THE VENTURI	6
REMOVING THE TRANSITION	6
PREPARING THE DROPPER	7
MOUNTING THE DROPPER	7
SECURING THE DROPPER & TRANSITION	7
WEATHER DAMPER	8
CONVEYING THE COOLER TO THE ROOF	8
MOUNTING THE COOLER	9
CABLE INSTALLATION	9
ELECTRICAL REQUIREMENTS	10
WATER REQUIREMENTS	10
WATER MANAGEMENT	11
INSTALLING THE DRAIN VALVE	11
INSTALLING THE WATER SENSOR	11
INSTALLING THE BLEED FUNNEL ALTERNATIVE	11
INSTALLING THE INLET SOLENOID	12
INSTALLING THE FLOAT VALVE	12
MAINS WATER CONNECTION	12
INSTALLING THE VENTURI / FAN ASSEMBLY	13
ELECTRICAL CONNECTION	13
CONNECTING THE WATER PUMP	14
CONNECTING THE MAGIQTOUCH CONTROLLER®	15
MAGIQTOUCH CONTROLLER® DISPLAY INFORMATION	15
SETTING THE WATER LEVEL	15
SETUP FOR BLEED FUNNEL	15
FAULT CODES INDICATED BY LED's ON THE ELECTRONICS MODULE	16
COMMISSIONING THE COOLER	16
COMMISSIONING COMPLETION CHECKLIST	17
ADJUSTING COOLER SETTINGS	18
TROUBLE SHOOTING	19

WARNING! Failure to install and commission the product in compliance with these instructions, or failure to do the job properly and competently, may void the customer's warranty. Further, it could expose the Installer and/or the Retailer to serious liability.

SAFETY

READ AND SAVE THESE INSTRUCTIONS

EMPLOYER AND EMPLOYEE RESPONSIBILITIES

The installation and maintenance of evaporative coolers at height has the potential to create Occupational Health and Safety issues for those involved. Installers are advised to ensure they are familiar with the relevant State and Federal legislation, such as Acts, Regulations, approved Codes of Practice and Australian Standards, which offer practical guidance on these health and safety issues. Compliance with these regulations will require appropriate work practices, equipment, training and qualifications of workers.

Seeley International provides the following information as a guide to contractors and employees to assist in minimising risk whilst working at height.

WARNING - TO REDUCE THE RISK OF FIRE, ELECTRIC SHOCK OR INJURY TO OTHER PERSONS, OBSERVE THE FOLLOWING:

1. Use this unit only in the manner intended by the manufacturer. If you have questions, contact the manufacturer.
2. Before servicing or cleaning the unit, switch power off at service panel and lock the service disconnecting means to prevent power from being switched on accidentally. When the service disconnecting means cannot be locked, securely fasten a prominent warning device, such as a tag to the service panel.
3. Installation work and electrical wiring must be done by qualified person(s) in accordance with all applicable codes and standards, including fire-rated construction.
4. When cutting or drilling into walls or ceilings, do not damage electrical wiring and other hidden utilities.
5. Ducted fans must always be vented to the outdoors.
6. Do not use this fan with any solid-state speed control device.
7. New hose sets supplied with the appliance are to be used. Old hose sets (from previous installations) shall not be used.
8. If the supply cord is damaged, it must be replaced by the Manufacturer, its Service Agent or similarly qualified persons in order to avoid a hazard.

INSTALLER AND MAINTENANCE CONTRACTORS – RISK ASSESSMENT

A risk assessment of all hazardous tasks is required under legislation. A risk assessment is an essential element that should be conducted before the commencement of work, to identify and eliminate the risk of falls or to minimise these risks by implementing control measures. There is no need for this to be a complicated process, it just is a matter of looking at the job to be done and considering what action(s) are necessary so the person doing the job does not injure themselves.

SAFETY cont.

This should be considered in terms of:

- What are the chances of an incident happening?
- What could the possible consequence be?
- What can you do to reduce, or better still, completely eliminate the risk?

Some points to consider:

- What is the best and safest access to the roof and working areas?
- If a worker is alone, who knows they are there and if they get into difficulty, how can they summon help? (Call someone on the ground? Mobile phone? etc.).
- What condition is the roof in? Should the trusses, underside or surface be checked?
- Does the worker have appropriate foot wear? (Flat sole jogger type is advisable).
- Are all power cables / extension leads safe and appropriately rated?
- Are all ladders, tools and equipment suitable in good condition?
- Where ladders are to be used, is there a firm, stable base for them to stand on? Can they be tied or secured in some way at the top? Is the top of the ladder clear of electricity supply cables?
- Is there a roof anchor to attach a harness and lanyard to? If so, instruction should be issued for the use of an approved harness or only suitably trained people used.
- Are all tools and materials being used, prevented from slipping and falling onto a person at ground level? Is the area below the work area suitably protected to prevent persons walking in this area?
- Does the work schedule take into account weather conditions, allowing for work to be suspended in high winds, thunder storms/lightning or other types of weather giving wet, slippery surfaces?
- Is there an on-going safety check system of harnesses, ropes, ladders and access/lifting equipment and where they exist on roofs, anchor points before the commencement of work?
- Is there a system which prevents employees from working on roofs if they are unwell or under the influence of drugs or alcohol?
- Are there any special conditions to consider i.e. excessive roof pitch, limited ground area, fragile roof, electrical power lines?

Other Important Requirements

- Never force parts to fit because all parts are designed to fit together easily without undue force.
- Never drill holes in the tank of the cooler.
- Check the proposed cooler location, to ensure that it is structurally capable of supporting the weight of the cooler, or provide an adequate alternate load bearing structure.
- Ensure the installation complies with all local and National regulations with regards to electrical, plumbing and bushfire construction requirements.

QUICK GUIDE

Step 1

SAFETY

Read & understand the safety section.



Page 3

Step 2

COOLER LOCATION

Check cooler location. Consider regulations. Discuss with customer.

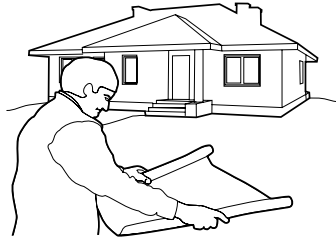

Page 6

Step 3

REMOVE VENTURI

Press the clip on both sides of the venturi to release.

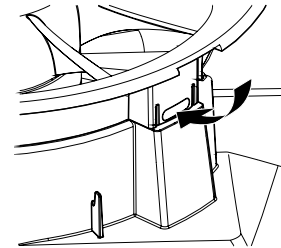

Page 6

Step 7

SECURE TRANSITION TO DROPPER

Use the TEK screws provided. Break the transport clips for the weatherdamper.

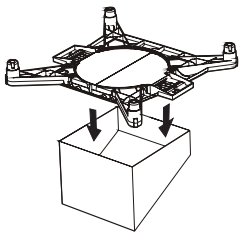

Page 7

Step 8

CHECK WEATHER DAMPER

Check operation of the weatherdamper. Ensure weatherdamper moves freely.

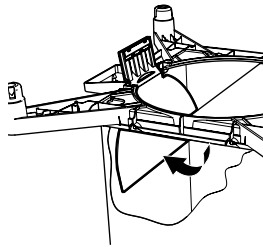

Page 8

Step 9

CONVEY COOLER TO ROOF

Always use 2 persons to position the cooler when handling manually.

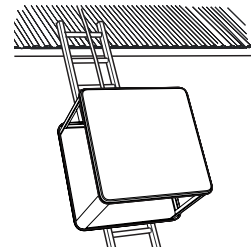

Page 8

Step 13

INSTALL DRAIN VALVE

(Where provided)

Never drain waste water directly onto the roof. Be sure to use supplied 'O' Rings and fittings.

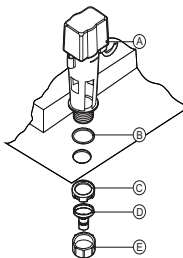

Page 11

Step 14

INSTALL WATER SENSOR

(Where provided)

Ensure the clip is fully engaged.

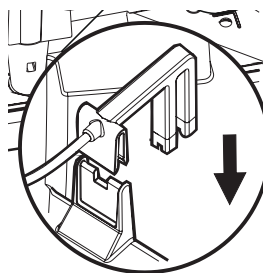

Page 11

Step 15

INSTALL INLET SOLENOID

(Where provided)

Use the supplied hose set and fittings. Note the water flow direction marking on the solenoid.

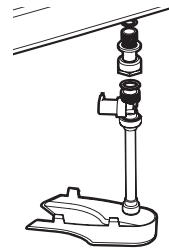

Page 12

Step 19

SET THE WATER LEVEL

Turn on the mains water and adjust the float to allow water to fill to the required level.

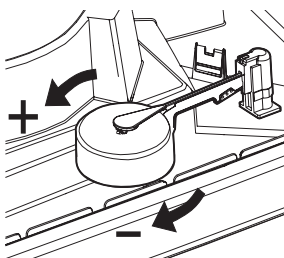

Page 15

Step 20

CHECK COOLER OPERATION

Switch the mains power on and test run the cooler, refer to the MagIQtouch Controller Installation Guide.

Page 16

Step 21

FINAL CHECK

Complete the commissioning checklist at the end of this document.



Page 17

QUICK GUIDE cont

Step 4

REMOVE TRANSITION

Press the clips inwards to release the transition from the tank.

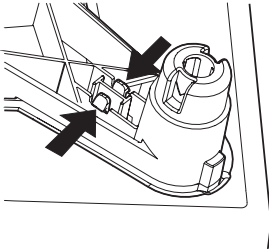

Page 6

Step 5

PREPARE THE DROPPER

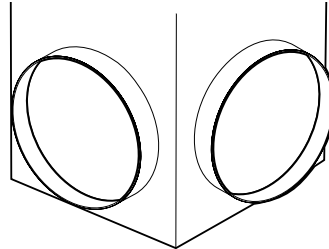

Page 7

Step 6

MOUNT DROPPER

Position, level and secure the dropper. Flash the dropper to prevent water ingress into the roof cavity.

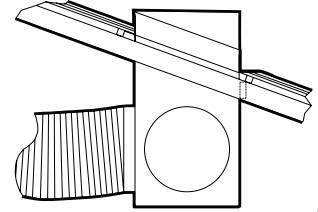

Page 7

Step 10

MOUNT THE COOLER

Lower the cooler onto the transition.

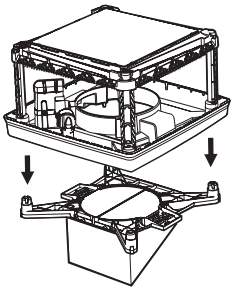

Page 9

Step 11

CABLE INSTALLATION

Run the power and control cable down the conduit and terminate in the junction box.

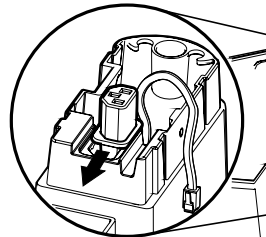

Page 9

Step 12

LOCAL REGULATIONS

Read and adhere to local electrical and plumbing rules and regulations.

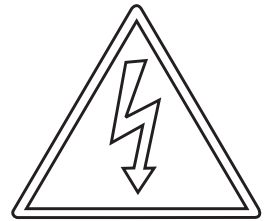

Page 10

Step 16

INSTALL VENTURI/FAN

Ensure the venturi is fully located into the tank and the motor lead is not caught or pinched.

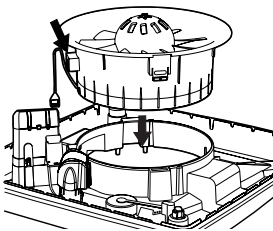

Page 13

Step 17

ELECTRICAL CONNECTIONS

Connect the cooler components to the electronics module. Plug the mains cable into the electronics module.

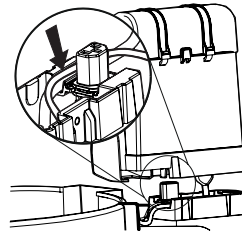

Page 13

Step 18

MOUNT AND CONNECT THE MAGIQTOUCH CONTROLLER

Refer to MagIQtouch Controller Installation Guide.



Page 15

Step 22

CLEAN UP

Clean up the site!



Page 17

Step 23

CUSTOMER HANDOVER

Show customer how to operate cooler. Give them both the controller and cooler owner's manual. Explain maintenance requirements.

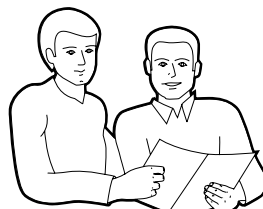

Page 17

COOLER LOCATION

Check proposed cooler location to ensure it is structurally capable of supporting the weight of the cooler. If the roof is structurally inadequate, provide an alternate load bearing structure.

The ideal location for the cooler is in a central position on the roof (away from sleeping areas and where people spend most of their time) so that the duct runs are of approximately the same length. Carefully consider neighbouring residences and noise levels when locating the cooler, if necessary talk to the customer and the neighbour before carrying out the installation.

Always locate the cooler where it will receive adequate fresh air and not in a recess where it may be starved for air or where the air is polluted. Ensure that the cooler is installed such that the fan is facing an unoccupied space.

Ensure location is a minimum of:

- 3m/10' from a solid fuel heater flue,
- 1.5m/5' from a gas flue,
- 5m/17' from a sewer vent, and
- 600mm/2' from a wall.

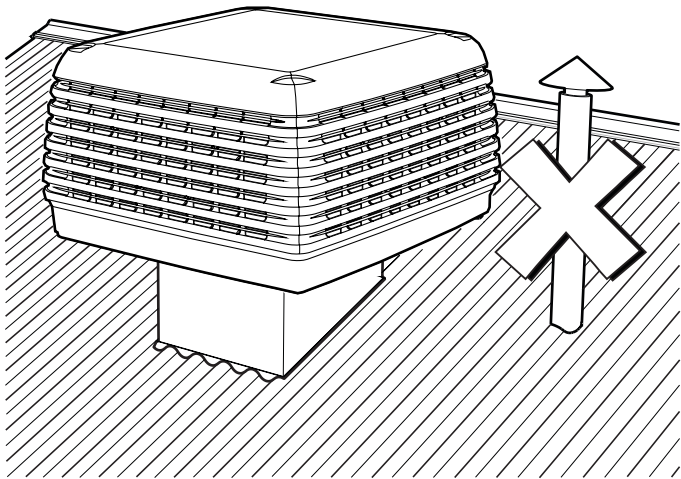

ILL1150-A

The cooler must be mounted at least 3m/10' (preferably 5m/17') away from any TV antenna or antenna cables.

Make sure the cooler is not between the antenna and the transmission tower that is providing the television signal to the home.

Allow adequate access to and around the cooler for maintenance. Provision must be made for access to electricity, water supplies and drains.

Note! Do you need to discuss the installation of items like safety anchor points with the customer?

REMOVING THE VENTURI

Once the pad frames have been removed, detach the venturi and fan assembly.

Disengage the two venturi clips as shown.

Note! Ensure the steel restraint cable and motor cable are secured against the side of the venturi by the sticker provided.

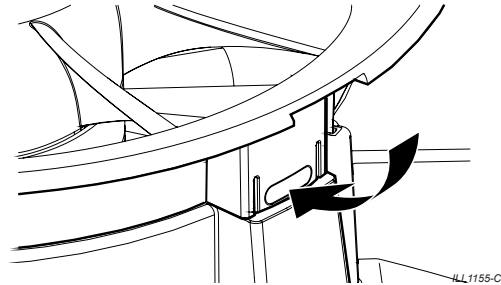

ILL1155-C

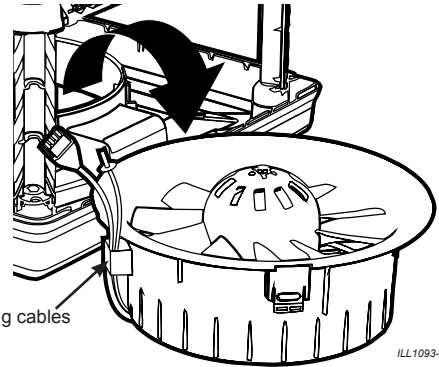

Sticker securing cables

ILL1093-E

Lift the venturi and fan assembly out of the cooler. Take care with the motor lead, which will be sitting loosely in the bottom of the cooler.

The venturi and fan assembly can be placed on to the ground until the rest of the cooler has been installed on the dropper.

REMOVING THE TRANSITION

Turn the cooler onto its side to remove the transition. There are clips in each of the four corners that will disengage once the transition is given a firm pull.

If any of the corners are difficult to remove do not use excessive force. Gently squeeze the clips together and remove the transition one corner at a time.

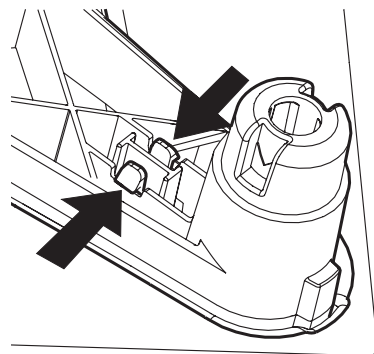

ILL1155-C

PREPARING THE DROPPER

The 550 x 550mm / 21.7 x 21.7" dropper duct must have a raw edge or safe edge at the top. Do not fold in a flange as this may interfere with the transition and/or weatherdamper.

MOUNTING THE DROPPER

Install the dropper and securely fix it to the roof structure on 3 sides. This may require the addition of extra structural timber.

Important! The dropper must never sit directly on any ceiling joists or beams, as this may cause noise or vibration issues, and possible ceiling damage.

Ensure the top of the dropper is level and square in all directions (use a spirit level). This helps with levelling the cooler.

The installer must ensure the dropper is suitable, and is secured adequately for wind conditions at the site. Additional restraints may be required if the cooler is more than 200mm/8" higher than the roof timbers, or design wind velocity at the site exceeds 43m/s / 141fps.

In exposed or very high wind areas use 16 screws, minimum shank diameter 5.2mm / 7/32" to secure the dropper. In areas subject to windstorms/hurricanes or where the cooler is located more than 8m/26' above the ground seek advice from a structural engineer.

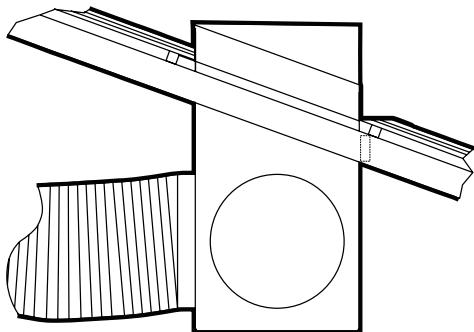

ILL1683-A

The dropper may now be flashed to the roof. Make sure there is no chance of water entering the roof space.

SECURING THE DROPPER & TRANSITION

Fit the transition onto the dropper as shown. Ensure that it is oriented correctly, as shown by the engraved detail on the transition.

Check the level of the transition on the dropper, with a spirit level placed across the flats in both directions.

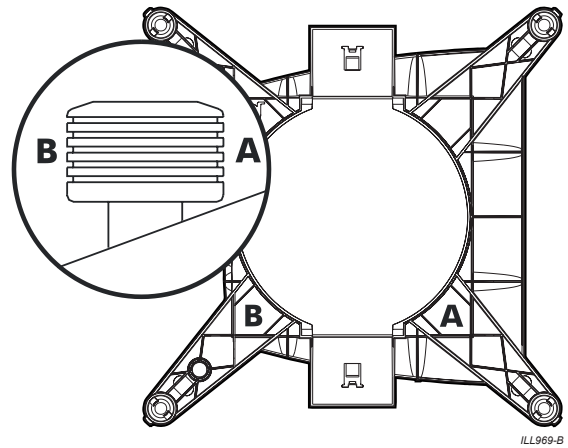

ILL969-B

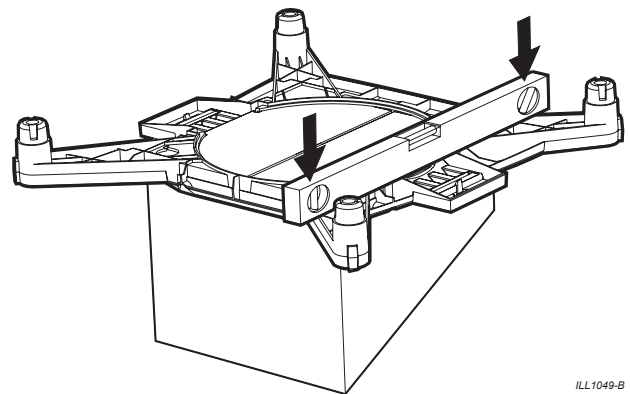

ILL1049-B

Once level, begin securing the transition to the dropper using the screws provided. There are eight 'V' notch locations for screws.

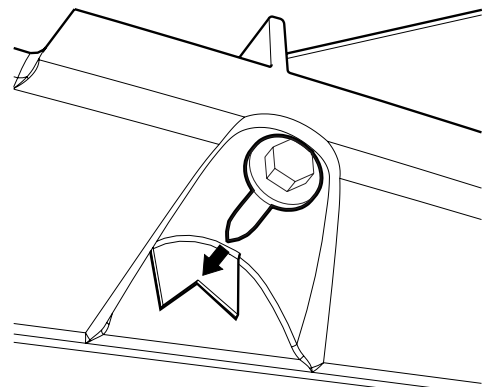

ILL967-B

Only use the screws provided. These must be used in the correct positions to prevent interference with the weatherdamper. All eight (8) screws must be used. Check the level periodically before driving in all the screws.

Ensure the duct insulation is firmly held against the duct connector flange on the dropper.

WEATHER DAMPER

Break off both clips on the transition that retain the weatherdamper.

Ensure that the weatherdamper flaps open all the way and do not interfere with the dropper or any screws. The flaps should move freely through 90°.

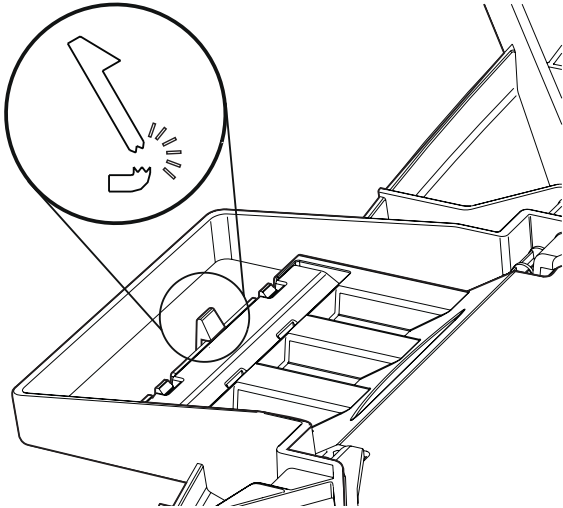

ILL983-B

Important! There must be no obstructions to the weatherdamper opening fully as it will adversely affect the performance of the cooler.

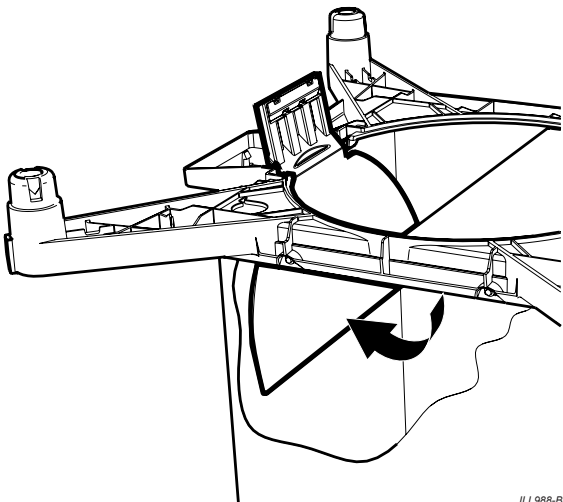

ILL988-B

CONVEYING THE COOLER TO THE ROOF

Caution! Do not take risks when raising the cooler to the roof for installation. Use safety equipment, appropriate procedures and always have assistance.

If you intend to pull the cooler onto the roof using a ladder as a slide, then guide the cooler on the underside of the tank.

It is recommended that at least 2 people move the cooler into position and that the transition, pad frames, venturi assembly and any unsecured objects are removed beforehand.

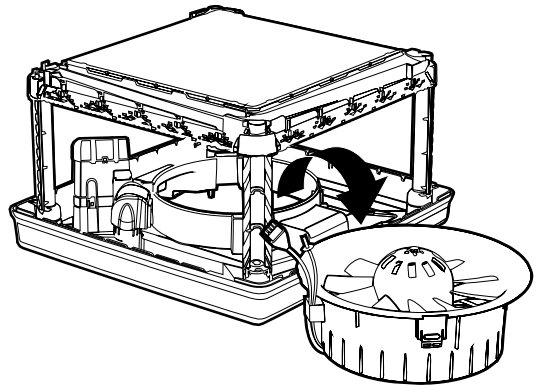

ILL1093-E

Attach ropes or slings through the central tank hole. Do not slide the cooler along the ground, lift and carry it. Do not drop the cooler. Always handle the cooler with care.

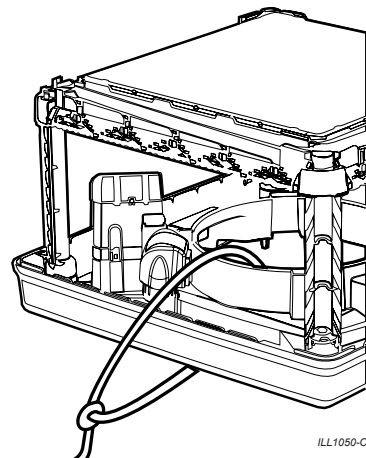

ILL1050-C

If you intend to pull the cooler to the roof using a ladder as a slide, then guide the cooler on the underside of the tank.

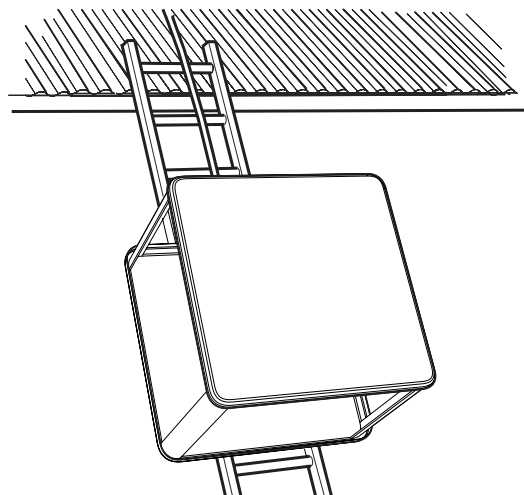

ILL1051-C

MOUNTING THE COOLER

Once the cooler is on the roof, carefully lift the assembly onto the transition and into place. The assembly will only fit onto the transition in one orientation. Refer to the engraved details moulded into the transition.

Ensure that the clips in all four corners engage correctly.

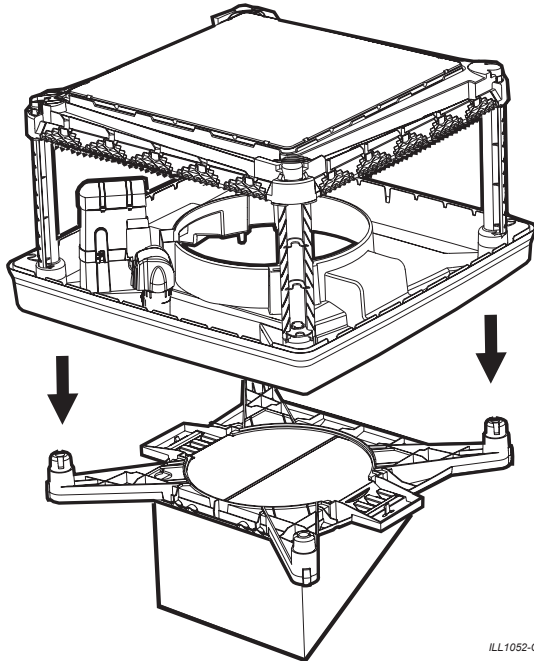

Do not use any screws to fix the cooler to the transition.

Important! Do not place the venturi assembly into the cooler at this stage.

CABLE INSTALLATION

After fitting the cooler to the dropper, disconnect the electronics module from the tank by removing the screw under the switch. The isolation switch cannot be activated with this screw removed.

Note! Place the electronics module and the screw safely to one side for later use.

Do not re-fit the electronics module, as the motor plug will require connection to the underside of the module when the venturi is refitted into the cooler.

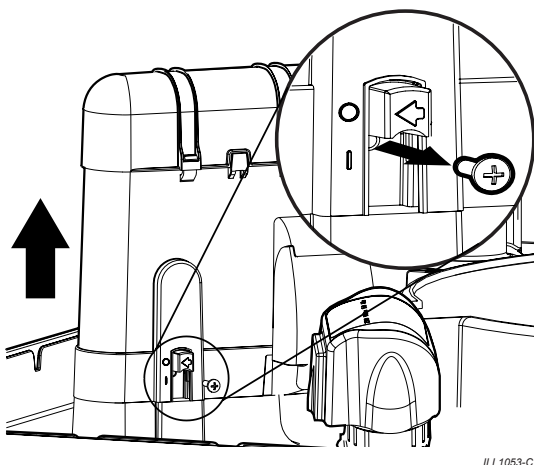

CABLE INSTALLATION cont.

Your installation kit includes the power cable with ends ready to terminate, and control cable.

Pass the taped end of the wall control cable through the conduit adaptor (factory fitted in the transition) and leave about 0.5m (20") in the water tank.

Take the power cable and drop the non-plug end down the hole where the electronics module was and pass it through the conduit adaptor. **Important!** Pass the wall control cable through the conduit first.

Lock the power cable socket in place by sliding the plug in sideways into the tank as shown.

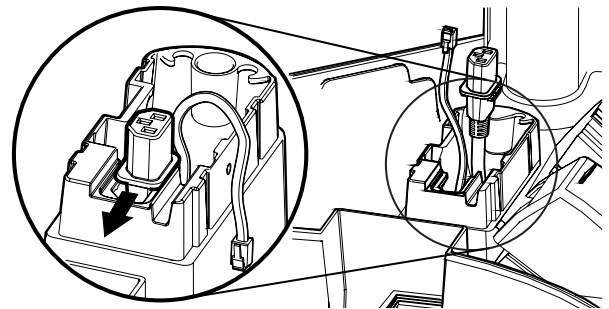

The plug will only insert one way, with the chamfered end first.

Now pass the cables through your main conduit and connect the main conduit to the conduit adaptor (under the transition).

Terminate the power cable in a junction box installed nearby. The fixed wiring must be fitted with an isolation switch that breaks the active (hot) and neutral (common) in accordance with local wiring rules. We recommend the junction box be located and installed on the duct.

Do not penetrate the duct near the weatherseal.

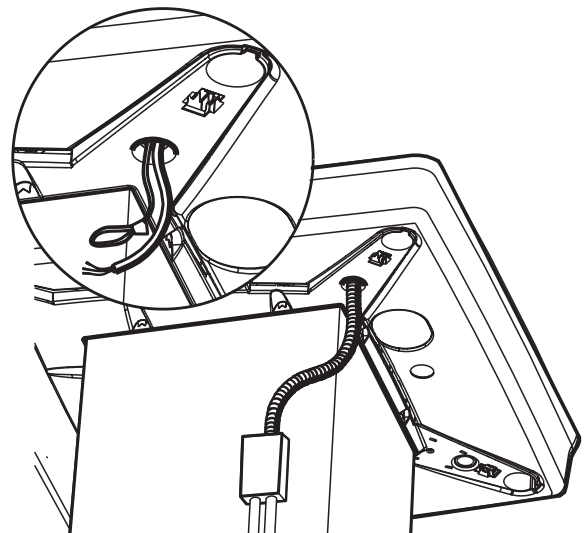

Note! The maximum length for the wall control cable to travel alongside the power cable is 10m (33').

WARNING! Do not let cables, cable ends, or the control box get wet. Position the cables in the dropper so they will be accessible from inside the roof space.

ELECTRICAL REQUIREMENTS

Installation of the cooler must conform to local electrical rules, regulations and standards.

Important! It is a requirement of Seeley International that all Breezair coolers be connected to a dedicated circuit to the distribution board, with a separate circuit breaker and incorporate a separate isolation switch in accordance with the local wiring rules and the National Electric Code.

The following specifications for the cooler electrical supply are required:

230V / 50Hz, 60Hz Single Phase (see nameplate for exact data for this cooler)

The electronics module is fitted with a 12A re-settable circuit breaker. To reset the circuit breaker turn off the isolation switch, remove the electronics module and push the manual reset toggle switch located underneath the electronics module.

WARNING! If the supply cord is damaged, it must be replaced by the manufacturer, its service agent or similarly qualified persons in order to avoid a hazard.

FIELD WIRING DIAGRAM

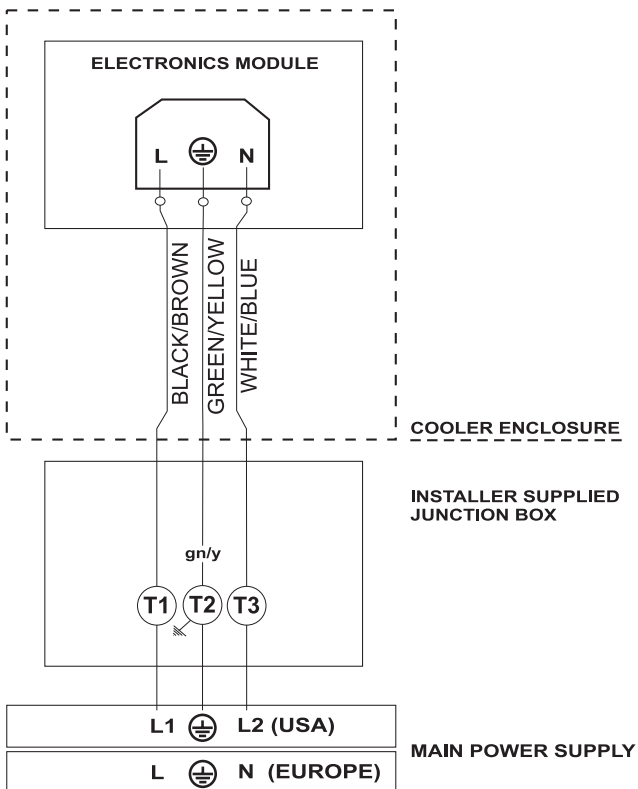

ILL1898-A

WATER REQUIREMENTS

Installation of the cooler water supply must conform to local plumbing rules, regulations and standards.

The following specifications for the cooler water supply are required:

Water Connection	½" BSP
Min Water Pressure	100kPa / 15psi
Max Water Pressure	800kPa / 115psi
Min Water Flow	8 liters/min / 2.1 gallons/min
Max Water Temperature	40°C / 104°F

Important! If the water pressure exceeds maximum specification then a pressure reducing valve is required and must be supplied and fitted by the installer.

A permanent water supply is required to be connected to the float valve. The water connection point is located on the underside of the cooler.

You must install a manual 1/4 turn ball type shut off valve (do not use a stop cock) in the water supply line adjacent to the cooler, subject to local plumbing regulations. This allows the water supply to be isolated whenever work needs to be done on the cooler.

The water connection is a 1/2" BSP compression fitting or a 1/2" BSP to 1/4" compression fitting on the end of a flexible hose. This can fit directly onto the water pipe or be screwed directly onto the manual water shut-off valve as required.

Always ensure that the water pipe connection does not place sideways strain onto the float valve.

Important! In areas subject to freezing, the water supply line to the cooler requires a drain down facility at the lowest point in the water supply pipe.

Important! Flush the water pipe to remove any swarf before final fitting. Swarf can lodge in the solenoid and float valve, preventing them from functioning correctly.

WATER MANAGEMENT

You have the choice of installing a water management system including a drain valve, water sensor and inlet solenoid; or a bleed funnel.

Both systems provide overflow and water drain features, however the water management system is also designed to actively reduce salt and mineral deposits in the air cooler.

INSTALLING THE DRAIN VALVE

Water drained from the cooler must be carried away to a suitable discharge point in accordance with local regulations.

Important! Never drain water from the cooler directly on to the roof.

Assemble the drain valve (A) as shown:

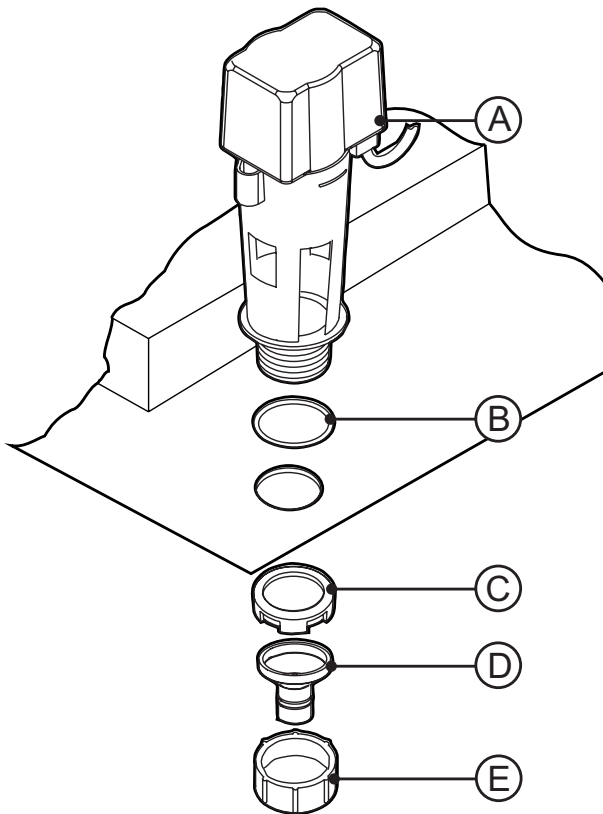

ILL746-E

Make sure the “O”-ring (B) is fitted before placing the drain valve into the hole. Screw the nut (C) up tightly by hand underneath to locate the drain valve. Locate the funnel (D) up against the bottom of the drain valve thread and secure with the second, larger nut (E).

Make sure that you use the correct drain adaptor.

Make sure the drain water discharge flows freely away from the cooler.

Important! Do not over-tighten plastic fittings.

INSTALLING THE WATER SENSOR

Assemble the water sensor as shown by clipping the sensor to the tank. Ensure that the clip fully engages.

Route the sensor cable through the cable supports in the tank as shown and leave the end clear of any water. The cable will be plugged in later.

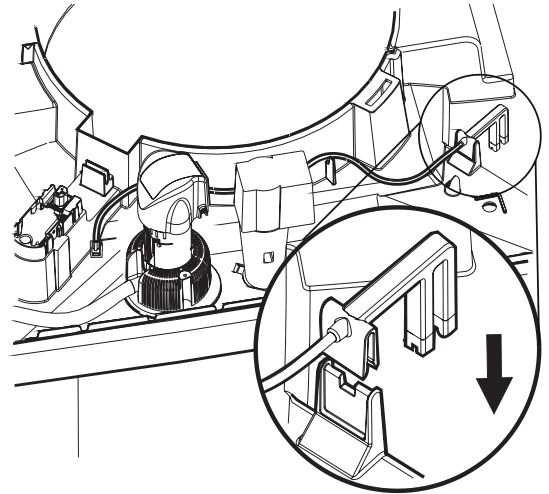

ILL1056-C

INSTALLING THE BLEED FUNNEL ALTERNATIVE

The bleed funnel is a simplified alternative to the drain valve. It also provides overflow and drain features.

Assemble the bleed funnel to the water tank as shown. Make sure the o-rings are fitted correctly. Screw the nut tight by hand!

Attach the drain adaptor under the bleed funnel and attach a pipe to carry the water to a suitable drain point.

Do not allow the water to run freely onto the roof - it will stain the roof!

The required rate of bleed will vary according to the water quality. Set it to the minimum rate, as shown in the following table.

TBQ250, TBS280, TBQ350, TBS380	1 plug in
TBQ450, TBS480, TBQ500, TBS500 TBQ550, TBS580	2 plugs in

If salt starts to build up on the cooling pads insert another plug. Adjust the bleed rate until the salt build up is minimised.

The water management devices fitted will help control the effects of poor quality water, but they cannot eliminate the problem.

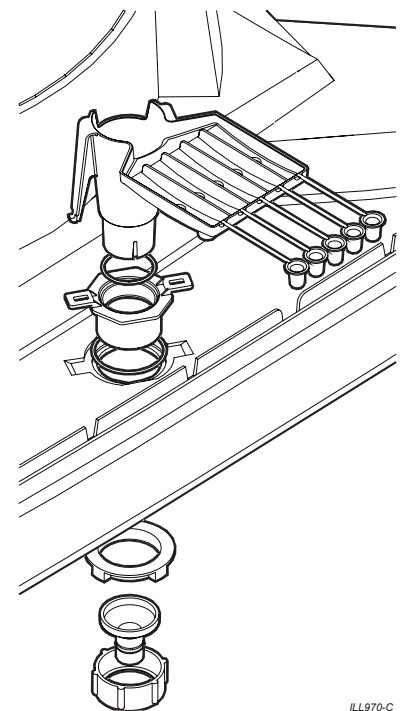

ILL970-C

INSTALLING THE INLET SOLENOID

Screw the solenoid valve into the extension tube.

The water solenoid is required to be installed in the direction of flow as per the arrow indicator on the solenoid.

Note! Tighten the solenoid valve until it seals against the rubber washer and is in the orientation shown such that the solenoid cover will clip on over the top.

For coolers fitted with a drain and solenoid valve, it is a requirement to fit the new detachable hose set supplied. Any old hose sets should not be re-used.

Attach the flexible hose to the inlet of the solenoid valve.

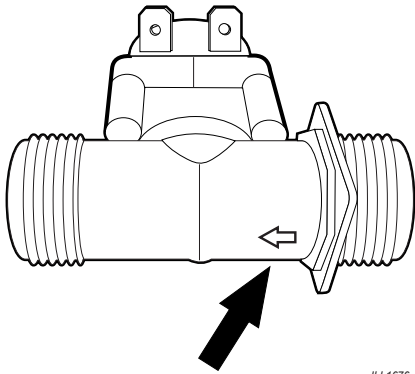

ILL1676-A

Connect the supplied cable to the solenoid valve, then push the other end through the hole in the transition as shown. Pull the cable through from inside the cooler and route the cable as shown. This will be connected later.

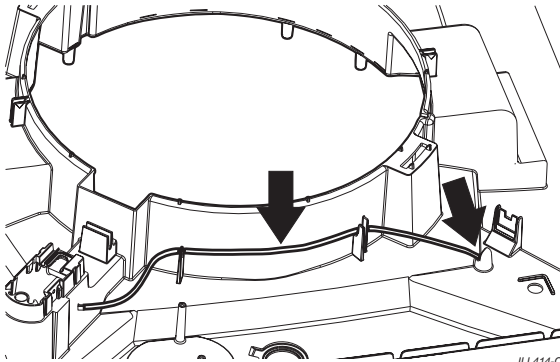

ILL414-C

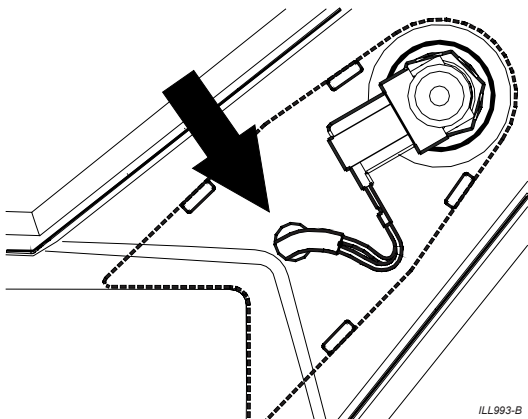

ILL993-B

Clip the solenoid cover in place.

INSTALLING THE FLOAT VALVE

Assemble the float valve to the cooler as shown.

Ensure all washers and o-rings are in place. No thread tape is required. Do not over-tighten the plastic fittings.

Make sure the float is centrally positioned and up and down movement is unrestricted.

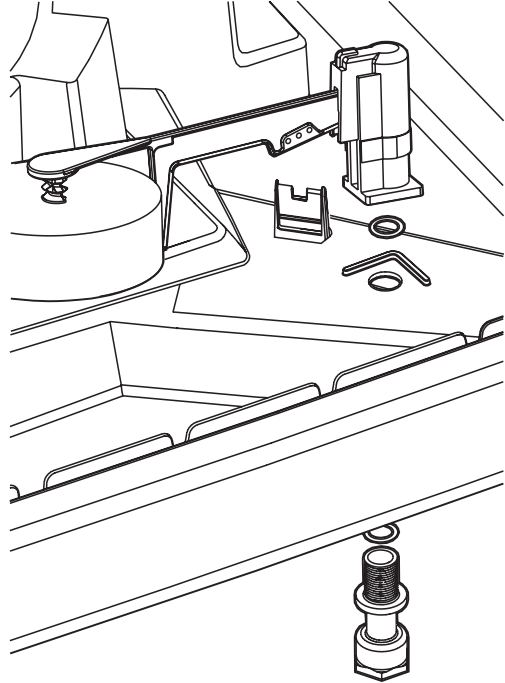

ILL985-E

MAINS WATER CONNECTION

CONNECTION DETAILS

For bleed funnel option, a 3/4" to 1/2" BSP adaptor is to be fitted with the washer to the extension tube as shown!

Connect the main water supply to the water inlet point under the air cooler using the 1/2" BSP Nut and olive fitting or 1/2" BSP - 1/4" brass compression adaptor fitting as required.

Always install a shut-off valve (do not use a non-return type valve) close by the air cooler.

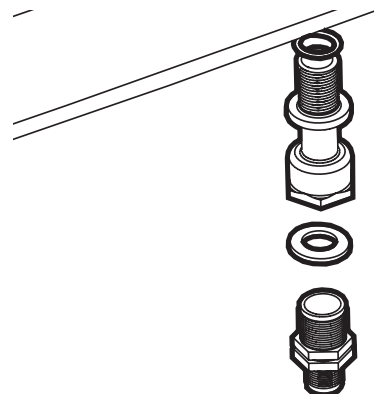

ILL972-C

INSTALLING THE VENTURI / FAN ASSEMBLY

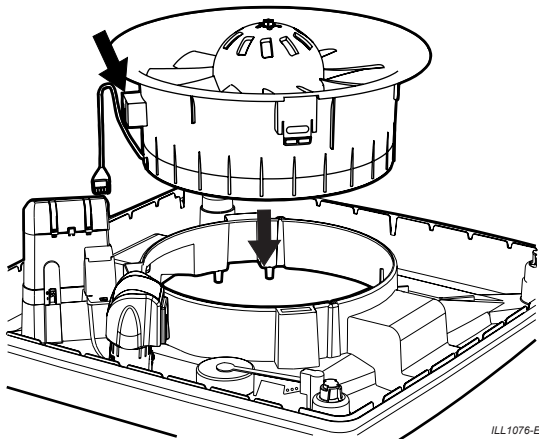

ILL1076-E

Ensure the bottom of the lead is aligned with the bracket inside the tank. Failure to do this may result in the cable being caught between the outside of the bracket and the venturi (B).

NOTE! Ensure the steel restraint cable and motor cable are secured against the side of the venturi by the sticker.

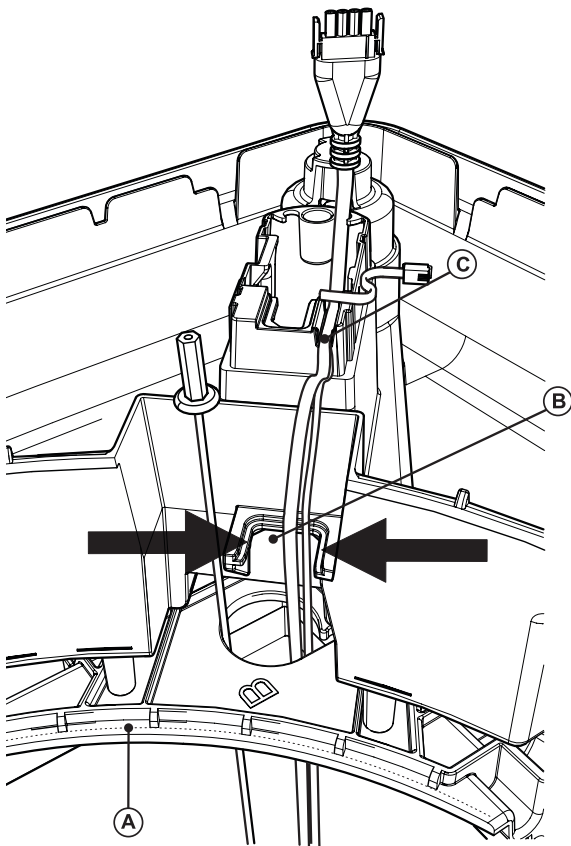

ILL1229-E

Important! Make sure the venturi is correctly and symmetrically located all the way around its cavity. Check this by making sure the venturi sits inside the locating ridge all the way around (A). Ensure the plug/lead assembly is not caught under the bottom lip of the venturi, by pulling the lead through fully.

Route the end of the wall control cable out of the cavity through channel "C" in the electronics module mounting bracket. Then feed the motor lead through channel "C" so that it sits on top of the wall control cable.

ELECTRICAL CONNECTION

Connect the motor cable to the base of the electronics module. It is a polarised plug and will only insert one way. Ensure it is secured fully so that its retention clips are engaged.

With both cables in place (inside the channel), re-assemble the electronics module and screw it to the tank.

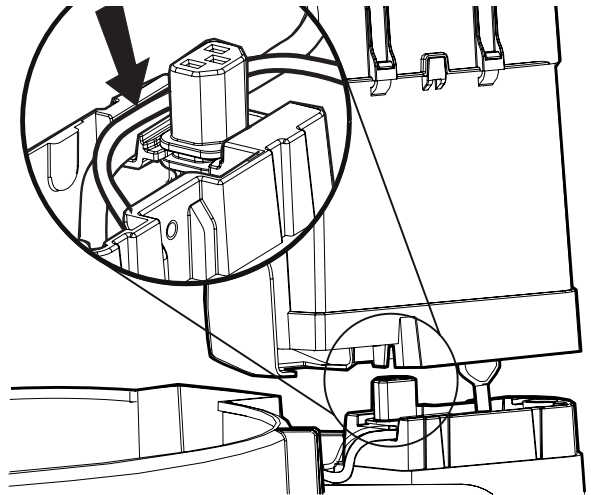

ILL496-B

Important! Ensure the motor lead sits on top of the wall control cable inside the channel to avoid interference with the electronics module and power cable connection.

Important! The isolation switch cannot be activated unless this screw is fixed in place.

Switch OFF the electronics module before connecting any accessories.

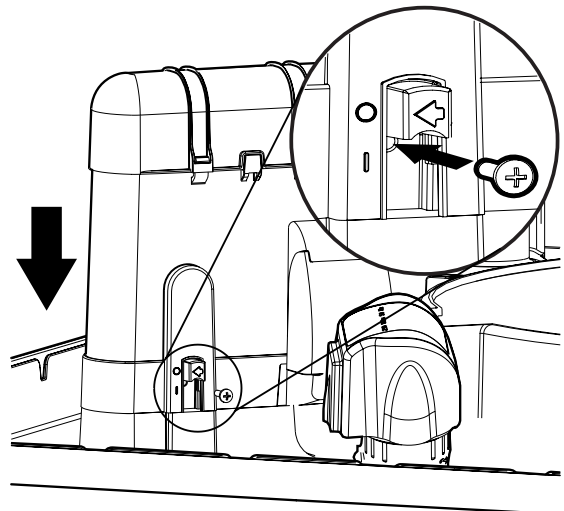

ILL1060-C

ELECTRICAL CONNECTION cont

Connect the water sensor plug (D) and inlet solenoid plug (C) as shown. If not using a water sensor, then ensure that a shorting plug is fitted as provided.

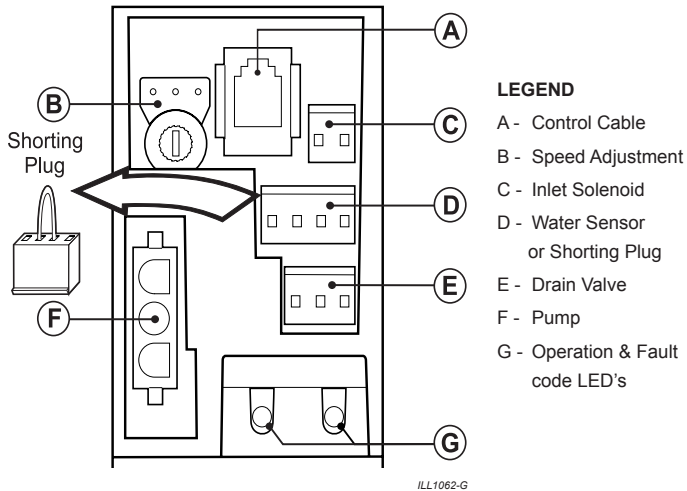

Route the drain valve cable as shown before connecting it to the electronics module (E).

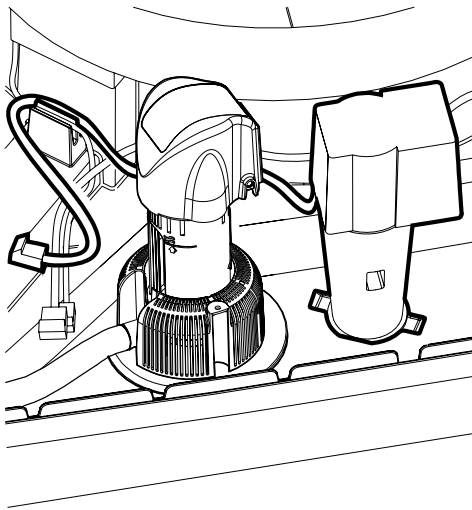

Ensure the cables cannot rest in the water once the tank is filled and plugs are connected in the correct orientation.

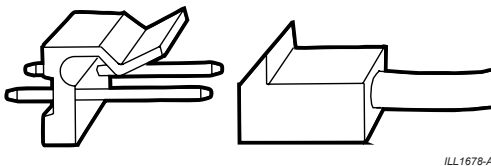

CONNECTING THE WATER PUMP

Route the pump cord as shown.

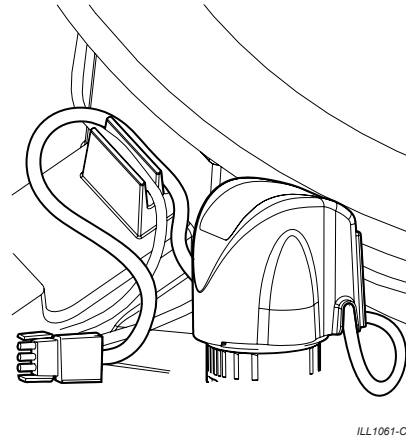

Once the water level is set correctly, isolate the electronics module and connect the pump plug (F).

Important! Do not connect the pump plug until the water level is set.

WARNING! Do not run the pump while the pad frames are off and the fan is on.

Once plugs are connected, switch the electronics module on.

Important! Ensure the flexible splash protection cover is in place.

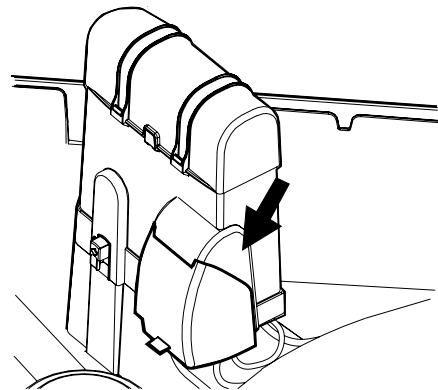

CONNECTING THE MAGIQTOUCH CONTROLLER®

Refer to the installation manual provided with the MagIQtouch Controller for instructions on installing the controller.

The wall control cable plugs into the electronics module - (A). (Refer diagram on previous page)

Coolers are supplied with a 20m / 66' control cable. Longer cable lengths are available from Seeley.

Note! Where maximum recommended cable lengths are exceeded, or cables are not routed in accordance with Seeley recommendations, Seeley technical support may not be available and the product warranty may be voided.

MAGIQTOUCH CONTROLLER® DISPLAY INFORMATION

Diagnosis and cooler operating information can also be viewed from the MagIQtouch Controller. Faults are displayed on the screen as they occur.



ILL1714-A

Cooler operating information is available from the 'Service Operating Screen' under the COOLER tab of the SETTINGS menu.

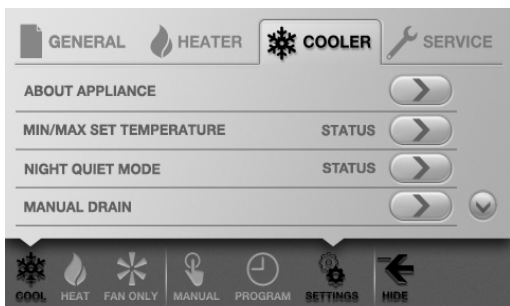

ILL1664-A

SETTING THE WATER LEVEL

Isolate power to the cooler electronics and disconnect the pump, making sure the plug is kept away from any water. Turn the power back on.

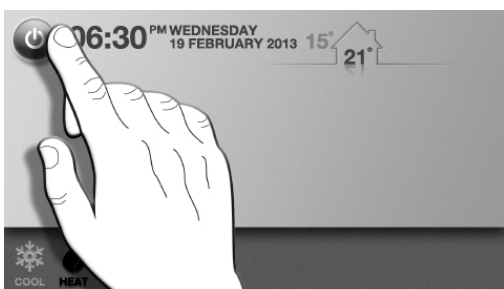

ILL1663-A

SETTING THE WATER LEVEL cont

Turn on the mains water supply to the cooler.

Turn the cooler on at the Controller, in "COOL" mode.

Adjust set temperature slider to be close to current room temperature so that fan speed remains low.

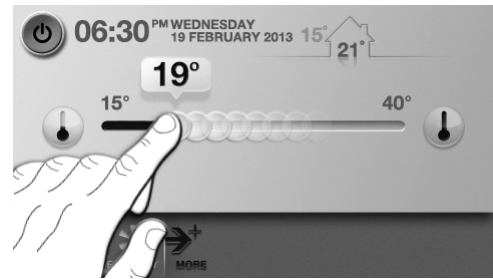

ILL1615-A

Allow the tank (reservoir) to fill with water. The float valve will eventually stop the water from entering the cooler. Wait for this to happen and check the water level.

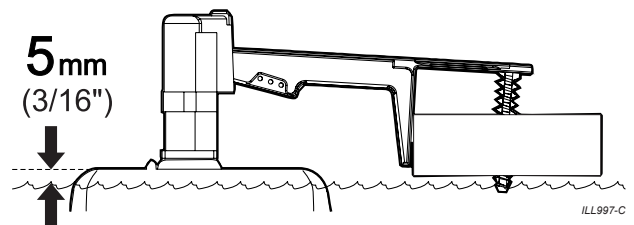

ILL997-C

If the level is too high rotate the float clockwise. Drain some water from the tank and allow it to refill to the new set point. If too low rotate the float in an anti-clockwise direction. The correct water level is approximately 5mm / 3/16" below the surface of the tank the float valve is mounted on. It is advisable to check the water level again after the float valve washer has "bedded in".

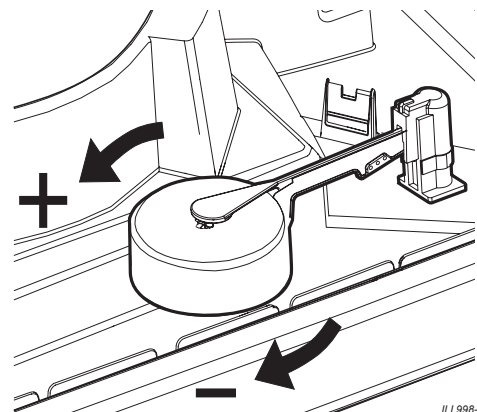

ILL998-D

Once the water level is correct, isolate the control box and connect the pump plug.

SETUP FOR BLEED FUNNEL

If you installed the bleed funnel instead of the drain valve then the cooler will automatically be set to "NO DRAIN CONTROL" provided that the shorting plug is installed correctly.

The "NO DRAIN CONTROL" setting can also be set manually under the "COOLER" tab in the "WATER MANAGER" menu.

FAULT CODES INDICATED BY LED'S ON THE ELECTRONICS MODULE

Fault Code 01 (1 Red Flash) = Communication Failure.

- Ensure the wall control cable is fitted correctly.
- Check that wall control cable is in good condition.

Fault Code 02 (2 Red Flashes) = Failure to detect water at probes within 8 minutes.

- Ensure water pressure is sufficient to fill and maintain the tank to specified level within 8 minutes.
- In areas of hard or polluted water, blockage of the strainer/ filter in the water inlet solenoid valve may restrict water flow.
- Water level set too low. For Breezair coolers the water level should be set to 5mm / 3/16" below the float valve base.
- Ensure probe plug is properly connected.
- Plug connections at electronic module upside down or misaligned.
- Water too pure for the probes to sense water is present.
- Pressure build up in pipes can lock up the solenoid valve when a non-return isolation valve is used in the water supply line. It is recommended to use a ball valve, i.e. NOT a non-return type of shut off valve.
- Check drain valve is closing and not cycling due to debris being caught under drain valve washer.

Fault Code 04 (4 Red Flashes) = Failure to clear probes during drain within 4 minutes (where drain valve fitted).

- Check the drain valve opens and water drains from the tank, with nothing obstructing the outflow of water. (e.g. drain hose kinked)
- Excessive drain hose lengths or bends cause air locking and won't allow water to drain.
- Build up of foreign material in drain hose not allowing water to drain away correctly.
- Screws used to fix drain hoses to drain adaptors restricting water from draining from tank.
- Drain valve has failed to open when drain was initiated.
- Inlet water solenoid not shutting off water when the drain is open.
- Water will only flow one way through the inlet water solenoid valve. Therefore, it must be installed correctly. Directional arrow must be pointing towards the float valve assembly. If not, water will not shut off. (Directional arrow can be found on the bottom of the solenoid valve body).
- Debris interfering with water sensor probes.
- Probes not clipped onto mounting brackets correctly.
- Check cooler is level and water drains quickly.

Fault Code 07 (7 Red Flashes) = Incorrect supply frequency (Hz).

This fault will only be seen when the mains power supply frequency deviates from normal frequency by more than 8%. Mains power supply frequency should be 50 or 60Hz. See nameplate for exact data for this air cooler. Petrol/gasoline generators are the most likely cause of this type of fault. This typically will not occur on mains power supplies.

COMMISSIONING THE COOLER

TEST OPERATION

Check that the green light on the electronics module is on and double flashing every 2 seconds. This indicates that power is connected to the electronics module.

Important! Ensure the flexible splash protection cover is put back in place.

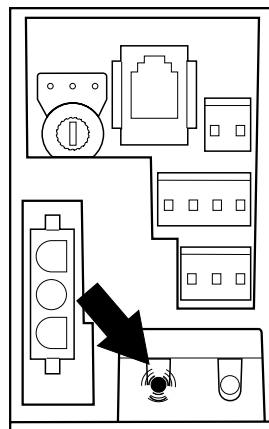

ILL1014-I

REFITTING THE PAD FRAMES

Refit the pad frames by locating the bottom edge in the tank groove, then push the top into the lid.

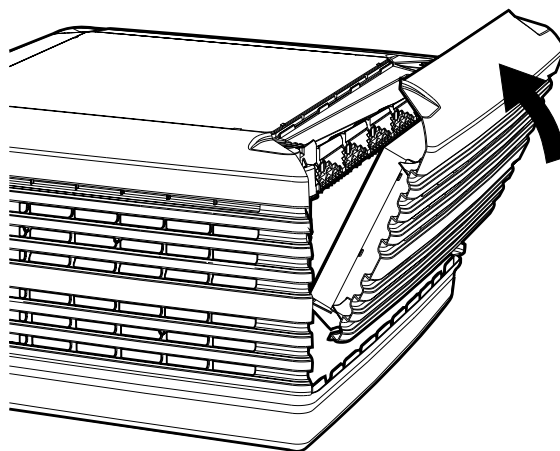

ILL976-D

TESTING THE PUMP

Test the pump by turning the cooler on at the MagIQtouch Controller, in "COOL" mode. Check that water is evenly distributed to all pads.

Note! If the cooler has not been on before it will run a "Pre-Wet" routine where the pump will operate to saturate the pads. This cycle takes 2 minutes, then the fan will start automatically.

TESTING THE DRAIN VALVE (WHERE FITTED)

Select the "SETTINGS" mode on the MagIQtouch Controller and select the "COOLER" sub-heading.

Select the "MANUAL DRAIN" option to operate and test the drain valve.

COMMISSIONING COMPLETION CHECKLIST

COOLER

- SECURE - The cooler is secure and level on the dropper using all fixings supplied.
- SEALED - The dropper and all penetrations are correctly flashed and sealed.

WEATHERDAMPER

- OPERATES - The weatherdamper operates correctly and can open and close without interference.

PLUMBING

- FLUSHED - The water pipes were flushed of any foreign materials before connection to cooler was made.
- NO EXTERNAL LEAKS - The water is connected with no leaks at fittings.
- NO INTERNAL LEAKS - Check all internal water hoses are securely fitted to water distribution spreaders and other internal fittings.
- SECURE - Water pipes are correctly saddled as per plumbing regulations.
- OWNER INSTRUCTIONS - The owner has been instructed on how to isolate the water to the system in case of emergency.

DRAIN VALVE / BLEED FUNNEL

- INSTALLED - The drain valve or bleed funnel is installed correctly, as detailed in this installation manual.
- DISCHARGE - The drain water does not discharge onto the roof surface.
- WATER LEVEL - Water level has been set correctly, as detailed in this installation manual.
- DRAIN VALVE TESTED (where fitted) - Drain the tank by pressing the Drain button. Check the drain fittings and pipes, making sure there are no leaks.

POWER

- REGULATIONS - The power supply adheres to all local and national regulations and is wired back to the distribution board on its own separate circuit.
- CHECK CABLES - Cables have been correctly connected to the control boxes:
 - Power supply
 - Motor cable
 - Control cable
 - Drain valve
 - Solenoid cable
 - Pump cable
 - Probe cable (where fitted)
- OWNER INSTRUCTIONS - The owner has been instructed how they can electrically isolate the unit at the meter box in case of an emergency.

COMMISSIONING COMPLETION CHECKLIST

cont

DUCTWORK

- NO LEAKS - All ducts are hung correctly and there are no air leaks.
- CONTROLLER SEALED - All wall holes behind the MagIQtouch Controller have been sealed.
- QUIET - Check that the cooler runs quietly and with an even distribution of air to all outlets.
- AIRBALANCE – The air balance for all outlets has been adjusted to the customer's satisfaction.

FINAL TEST

- Once you are satisfied that the cooler is installed and commissioned correctly, run the cooler and ensure that everything is working as it should.

CUSTOMER HANDOVER

- Principles of Ducted Evaporative Cooling explained.
- How far the windows need to be opened.
- How to turn the cooler on.
- How to operate the MagIQtouch Controller.
- How to drain the cooler.
- How to turn the power and water off.
- Maintenance requirements.
- The customer has been given the Owner's Manuals & Warranty Card.

CLEAN-UP

- All the installation rubbish has been removed and, if applicable, any property damage repaired. Your aim should be to have the customer not even be aware that you have been on site.

FINAL CHECK

- With all side panels in place and the unit running for a short period in cooling mode, ensure all pads have even water saturation and there are no visible water leaks

ADJUSTING COOLER SETTINGS

Within the SETTINGS menu of the MagIQtouch Controller is the COOLER sub-heading. Here various settings of the cooler can be adjusted.



ILL1664-A

ABOUT APPLIANCE

Displays information such as model number, serial number and software version for all coolers connected to the controller.

NIGHT QUIET MODE

Restricts fan speed to a specified level during a specified night period.

MANUAL DRAIN

Turns cooler off and drains the tank.

PAD FLUSH

Turns cooler off and runs pump for a specified amount of time.

AUTO RESTART

By turning this option to 'ON', the cooler will automatically restart after a power failure.

DRAIN AND DRY

Cooler will drain and fan will run for 1 hour every day at a specified time.

WATER MANAGER

Select the preferred water management method:

- Salinity Measurement - replaces water when Salinity level reaches set point.
- Timed Drain - drains Tank After 8 tank fill cycles or every 1-2 hours (system dependant).
- No Drain Control - salinity control external to electronics eg. continuous bleed.
- No Water Thermostatic - allows Thermostatic control in VENT mode. No water present. Cooling performance is limited.

WEATHER SEAL OPEN SPEED

The cooler fan will turn on at the specified weather seal opening speed for the first 10 seconds each time it starts up. It will then return to the set fan speed.

ADJUSTING COOLER SETTINGS cont

PRE-WET

When COOL mode is activated, the pump will run for 90 seconds before the fan is switched on.

SALINITY LEVEL

Sets the salinity level at which the tank will drain in "SALINITY MEASUREMENT" mode.

TANK DRAIN DELAY

Sets the time delay before the drain valve opens after the pump in the cooler is turned off.

AUTOSTART

Automatically restarts the cooler in the last operating mode after a power outage.

TROUBLE SHOOTING

Symptom	Cause	Action
Inadequate cooling	Under-sized cooler.	Replace with larger cooler.
	Under-sized ducts.	Carry out cooling load design to determine correct size unit, ducting and outlets required.
	Clogged or dirty cooling pads.	Clean or replace pads.
	Dry pads or lack of water while cooler is operating.	Check water distribution system for possible obstruction in hoses. Check pump.
	Insufficient air discharge openings or inadequate exhaust from building, causing high humidity and discomfort.	Make sure there is adequate provision for exhausting stale air from building (open windows and doors).
	Excessive ambient humidity (see also item above re inadequate exhaust).	On days during summer when ambient humidity is high the cooler will not reduce the temperature as much as on drier days. There is no remedy except to shut off the pump.
Noisy cooler	Fan out of balance due to dirt, etc.	Clean the fan.
	Too much back pressure. Tight duct bends. Grilles too small.	Re-evaluate design; improve duct layout; change grille sizes.
Pump fails to operate.	Circuit breaker tripped.	Check pump for faults. Replace if necessary.
	Pump motor failure.	Replace pump.
Fan fails to start.	Main power circuit breaker tripped.	Check cause of overload. Reset circuit breaker.
	Fan motor burned out.	Replace motor.
	Low system voltage.	Consult with power supply authority.
	Check fault condition via the tri-colour LED on cooler electronics module.	Rectify fault as indicated and restart the cooler.
	MagIQtouch Controller failure.	Replace MagIQtouch Controller.
Pump runs but no water circulation or Pump runs but pads lack water	Insufficient water in tank.	Adjust float level.
	Water hoses blocked.	Check and clean out blockage.
	Pump strainer blocked.	Clean pump strainer.
	Insufficient water supply pressure	Check and confirm water supply pressure
	Water solenoid is installed incorrectly	Check installed in the correct water flow direction
Continuous overflow of water.	Float valve adjustment not correct.	Adjust float valve.
	Heavy pad deposits.	Clean or replace pads.
	Drain Valve failure.	Replace Drain Valve.
	Water solenoid is installed incorrectly	Check installed in the correct water flow direction
Water entering cooler outlet.	Loose water hose connections.	Tighten connections.
	Water hose broken.	Replace cracked or broken hoses.
	Cover not fitted on float valve.	Replace float valve.
	Pads not fitted correctly into pad frames.	Install pad frame correctly.
	Incorrect or damaged pads.	Replace with new Chillcel pads.
Unpleasant odour.	New cooler pads.	Drain tank, refill, run pump for a few hours. Odour will dissipate after a number of hours of operation.
	Cooler located near source of unpleasant odour.	Remove source of odour or relocate cooler.
	Algae in tank water.	Drain pan, clean thoroughly with strong cleansing agent, refill, change pads.
	Pads remain wet after shut down.	Run fan on "vent" for 10 minutes after cooling cycle to dry pads out.
	Heavy pad deposits.	Clean or replace pads.



Service - All regions: Please contact your local Breezair distributor.

seeleyinternational.com

MANUFACTURED BY: SEELEY INTERNATIONAL PTY LTD
112 O'SULLIVAN BEACH RD, LONSDALE SA, 5160. AUSTRALIA

IMPORTED BY: SEELEY INTERNATIONAL (EUROPE) LTD
5 PAPPLEWICK LANE, HUCKNALL, NOTTINGHAM, NOTTINGHAMSHIRE, NG15 7TN, UNITED KINGDOM

SEELEY INTERNATIONAL (AMERICAS) LTD
1202 NORTH 54TH AVENUE, BUILDING 2, SUITE 117, PHOENIX, ARIZONA 85043, USA

It is the policy of Seeley International to introduce continuous product improvement.
Accordingly, specifications are subject to change without notice.
Please consult with your dealer to confirm the specifications of the model selected.

Breezair
NUMBER ONE IN NATURAL COOLING