

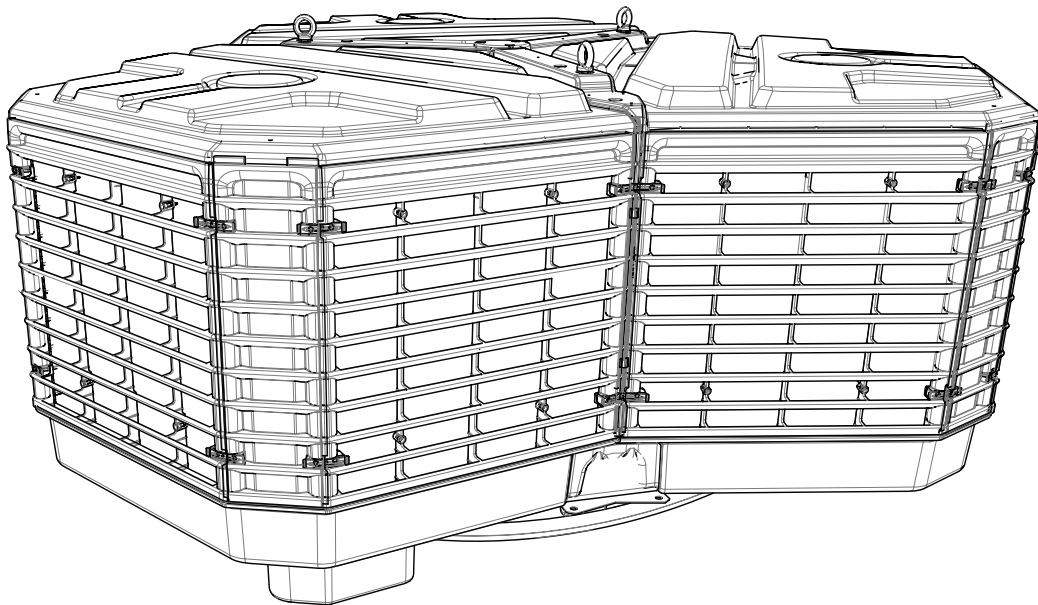

INSTALLATION, OPERATION & MAINTENANCE

EnviroMagic ENV600, ENV1000 Commercial / Industrial Evaporative Cooler



(ENV English)

IMPORTANT NOTES

INSTALLER'S NOTE

WARNING! Failure to install and commission the product in compliance with these instructions, or failure to do the job properly and competently, may void the customer's warranty. Further, it could expose the Installer and/or the Retailer to serious liability.

IMPORTANT

As with any product that has moving parts or is subject to wear and tear, it is **VERY IMPORTANT** that you maintain your cooler and have it regularly serviced. It is a condition of warranty cover for your cooler that you comply with all of the maintenance and service requirements set out in this Manual. Compliance with these requirements will prolong the life of your cooler. Further, it is also a condition of warranty cover that each item in the Maintenance Schedule in the Manual is filled out (by signing and dating it in the places indicated) when the item is completed.

Any failure to carry out the required maintenance and servicing, and any failure to fill out the maintenance schedule, will void your warranty.

TABLE of CONTENTS

SAFETY

Save These Instructions For Future Reference	4
Employer And Employee Responsibilities	4
Risk Assessment	4
Some Points To Consider	4
Other Important Requirements	5
Installation & Operation	5
For Australian Bushfire Zones	5

ENV600 COOLER SPECIFICATIONS 6

ENV1000 COOLER SPECIFICATIONS 7

GENERIC COOLER SPECIFICATIONS 8

COOLER CONTENTS 9

QUICK GUIDE 10

INSTALLATION

Location Requirements	12
Moving The Cooler	12
Removing The Cooler From A Container	12
Lifting The Cooler	12
Unpacking The Cooler	13
Removing Pad Frames	13
Mounting The Dropper/Curb	13
Cooler Services	13
Mounting The Cooler	14
Vibration Isolation	14
Fixing The Cooler To The Mounting Frame	14
Removing The Transport Protection Plate	14
Flexible Duct Fitting	14
Installing Mains And Control Cables	15
Connecting The Drain Valves	15
Electrical Supply Installation Wiring ENV600	16
USA ENV600 Wiring Diagram	16
Eur/Aust ENV600 Wiring Diagram	16
Electrical Supply Installation Wiring ENV1000	17
USA ENV1000 Wiring Diagram	17
Eur/Aust ENV1000 Wiring Diagram	17
Transformer Adjustments (USA ENV1000 Only)	17
Water Supply Installation	18
Control System	19
Wall Control Cable Wiring	19
Running The Control Cable To The Wall Control	19
Locating The Wall Control	19
MagIQtouch Controller Operation	20
MagIQcool Controller Operation	20
Manual Mode	20
Auto Mode	20
Mounting The Wall Control	21
Testing The Cooler	21
Turning Cooler On, Check Fan Operation	21
Checking Pump Operation	21

Checking Drain Operation	21
Control Parameters	22
Changing Control Parameters	22

OPERATING INSTRUCTIONS

Wall Control	23
Turning Cooler On	23
Preparing to Start	23
Manual Mode	23
Auto Mode	23
Auto Mode	23
Delayed Start and Stop	23
Programming in Manual Mode	23
Programming in Auto Mode	23
Service Mode	24
EnviroMagic Fault Codes	24
Salinity Control	24
Drain Mode	24
Power Outages	24

TROUBLE SHOOTING 25

MAINTENANCE

Seasonal Maintenance	26
End Of Season	26
Pre-Season	26
Replacing The Fuse In The Control Enclosure	26
Servicing & Inspection Details	27

INSTALLATION CHECKLIST 28

REGISTER YOUR PRODUCT WARRANTY (Australia only)

Warranty Terms And Information (Australia Only)	29
---	----

NOTES 32

SAFETY

READ AND SAVE THESE INSTRUCTIONS FOR FUTURE REFERENCE

FOR EUROPE

This appliance can be used by children aged from 8 years and above and persons with reduced physical, sensory or mental capabilities or lack of experience and knowledge if they have been given supervision or instruction concerning use of the appliance in a safe way and understand the hazards involved. Children shall not play with the appliance. Cleaning and user maintenance shall not be made by children without supervision.

FOR AUSTRALIA, NEW ZEALAND & OTHER NON-EUROPEAN COUNTRIES

This appliance is not intended for use by persons (including children) with reduced physical, sensory or mental capabilities, or lack of experience and knowledge, unless they have been given supervision or instruction concerning use of the appliance by a person responsible for their safety. Children should be supervised to ensure that they do not play with the appliance.

WARNING - TO REDUCE THE RISK OF FIRE, ELECTRIC SHOCK OR INJURY TO OTHER PERSONS, OBSERVE THE FOLLOWING:

- Use this unit only in the manner intended by the manufacturer. If you have questions, contact the manufacturer.
- Before servicing or cleaning the unit, switch power off at service panel and lock the service disconnecting means to prevent power from being switched on accidentally. When the service disconnecting means cannot be locked, securely fasten a prominent warning device, such as a tag to the service panel.
- Installation work and electrical wiring must be done by qualified person(s) in accordance with all applicable codes and standards, including fire-rated construction.
- When cutting or drilling into walls or ceilings, do not damage electrical wiring and other hidden utilities.
- Ducted fans must always be vented to the outdoors.
- **Important!** New hose sets supplied with the appliance are to be used. Old hose sets (from previous installations) should not be re-used.
- It is a requirement of Seeley International that all coolers be wired with a dedicated circuit to the distribution board and also fitted with an all pole disconnection switch in the fixed wiring in accordance with local wiring rules.
- The switch should be located in a position that is easily accessible and visible when servicing the cooler.

EMPLOYER AND EMPLOYEE RESPONSIBILITIES

The installation and maintenance of evaporative coolers at height has the potential to create Occupational Health and Safety issues for those involved. Installers are advised to ensure they are familiar with the relevant State and Federal legislation, such as Acts, Regulations, approved Codes of Practice and Australian Standards, which offer practical guidance on these health and safety issues. Compliance with these regulations will require appropriate work practices, equipment, training and qualifications of workers.

Seeley International provides the following information as a guide to contractors and employees to assist in minimising risk whilst working at height.

INSTALLER AND MAINTENANCE CONTRACTORS – RISK ASSESSMENT

Seeley International provides the following information as a guide to contractors and employees to assist in minimising risk whilst working at height.

A risk assessment of all hazardous tasks is required under legislation. A risk assessment is an essential element that should be conducted before the commencement of work, to identify and eliminate the risk of falls or to minimise these risks by implementing control measures. There is no need for this to be a complicated process, it just is a matter of looking at the job to be done and considering what action(s) are necessary so the person doing the job does not injure themselves.

This should be considered in terms of:

- What are the chances of an incident happening?
- What could the possible consequence be?
- What can you do to reduce, or better still, completely get rid of the risk?

SOME POINTS TO CONSIDER

- What is the best and safest access to the roof and working areas?
- If a worker is alone, who knows they are there and if they get into difficulty, how can they summon help? (Call someone on the ground? Mobile phone? etc.)
- What condition is the roof in? Should the trusses, underside or surface be checked?
- Does the worker have appropriate foot wear? (Flat sole jogger type is advisable)

SAFETY

- Are all power cables/extension leads safe and appropriately rated?
- Are all ladders, tools and equipment suitable in good condition?
- Where ladders are to be used, is there a firm, stable base for them to stand on? Can they be tied or secured in some way at the top? Is the top of the ladder clear of electricity supply cables?
- Is there a roof anchor to attach a harness and lanyard to? If so, instruction should be issued for the use of an approved harness or only suitably trained people used.
- Are all tools and materials being used, prevented from slipping and falling onto a person at ground level? Is the area below the work area suitably protected to prevent persons walking in this area?
- Does the work schedule take into account weather conditions, allowing for work to be suspended in high winds, thunder storms/lightning or other types of weather giving wet, slippery surfaces?
- Is there an on-going safety check system of harnesses, ropes, ladders and access/lifting equipment and where they exist on roofs, anchor points before the commencement of work?
- Is there a system which prevents employees from working on roofs if they are unwell or under the influence of drugs or alcohol?
- Are there any special conditions to consider? i.e. excessive roof pitch, limited ground area, fragile roof, electrical power lines?

OTHER IMPORTANT REQUIREMENTS

Please read this manual carefully. Your failure to do so could result in injury to you or damage to the cooler and property.

- Never force parts to fit because all parts are designed to fit together easily without undue force.
- Never drill any holes in the primary base surface or side walls of the bottom tank (reservoir) of the cooler.
- Check the proposed cooler location, to ensure that it is structurally capable of supporting the weight of the cooler, or provide an adequate alternate load bearing structure.
- Disconnect electrical power at the fuse or circuit breaker distribution board and turn "OFF" the all pole disconnection switch fitted in the fixed hard

wiring before you begin to install the cooler.

- Always comply with your local laws and safety regulations.

INSTALLATION & OPERATION

- Installation of the cooler must comply with local electrical, water supply and environmental codes, laws and safety regulations as well as with applicable National Standards.
- Dress safely. Wear non-slip shoes at all times. Open shoes, sandals and bare feet are NOT safe when working with tools and machines.
- Do not wear loose clothing and decorations while installing the cooler as they can get caught in the moving parts.
- Keep long hair, loose clothing and fingers away from moving parts.
- Do not install the cooler during rain, high winds, or severe weather conditions.
- Wear protective clothing when working with power tools.
- Always ensure that electrical power cables conform to relevant government safety requirements. Always lift the cooler to its location using safe methods and equipment.
- Never drain the cooler directly onto the roof. Always use pipes to carry the drain water to a proper point. Failure to do this can stain the roof and make the roof slippery and unsafe.
- All installation, maintenance and repair work must be done by trained and qualified technicians.
- The plastic packaging from the cooler can be a safety hazard. Please dispose of it in accordance with local laws and regulations
- ALWAYS route cables at least 300mm (1') away from regular power cables and high power machines. Cross over power cables at right angles.
- Where maximum data cable and sensor cable lengths are exceeded, or cables are not routed in accordance with Seeley recommendations, Seeley technical support is not available and the product warranty may be voided.

FOR AUSTRALIAN BUSHFIRE ZONES

MODEL GROUP: ENV600/ENV1000

WARNING: This cooler is NOT APPROVED for installation in any bushfire zoned area/property. (BAL-12.5 to BAL-FZ).

ENV600 COOLER SPECIFICATIONS

Airflow	L/sec @ 80Pa (cfm @ 0.3 IWG)	4,940 l/sec (10,680cfm)
Power Supply (Europe / Australia)	Voltage/Phases/Hz	380V - 415V / 3~ / 50Hz
	Rated Current (Amp)	3.5A / phase (3~, 415V)
	Voltage/Phases/Hz	220V - 240V / 1~ / 50Hz
	Rated Current (Amp)	10.5A
Power Supply (USA)	Voltage/Phases/Hz (USA)	200V - 240V / 3~ / 60Hz
	Rated Current MCA (Amp)	6.0A / phase
	MOPD (amp)	15A
Controller	Type	Variable speed
Fan x 3	Type	Axial
Motor x 3	Type	Inverter - Variable speed
	Speed max. RPM	1,330 RPM
	Power	430W each motor
	Current	3.2A
	Voltage/Phases/Hz	200V - 240V / 1~ / 50-60Hz
	Overloads	Auto-reset and "One Shot"
Pump x 3	Type	Centrifugal
	Motor	Synchronous
	Rating Watts input/motor	25W each pump
	Flow Rate l/min (gallons/min)	21 l/min (5.5 gallons/min)
	Voltage/Phases/Hz	220V - 240V / 1~ / 50Hz (Eur/Aus) 60Hz (USA)
Cooling Pad Chillcel	Size mm (inches)	593 (23.5") x 550 (21.5") x 100mm (4.0") (9 Pads)
	Pad Area m ² (square feet)	2.9m ² (31ft ²)
Water	Tank capacity litres (gallons)	48 litres (13 gallons)
	Water Inlet (inches)	1/2" male BSP
Drain Valve	Voltage	12V
	mm (inches)	40mm (1 1/2") male
Shipping	Dimensions max. mm / (inches)	1,935 (76") x 2,150 (85") x 890mm (35") (H)
	Mass kg (lb)	190kg (419lb)
	Operating kg (lb)	265kg (584lb) (water tanks full)
Connecting Duct	Length & Width mm (inches)	800mm (31.5") x 800mm (31.5")

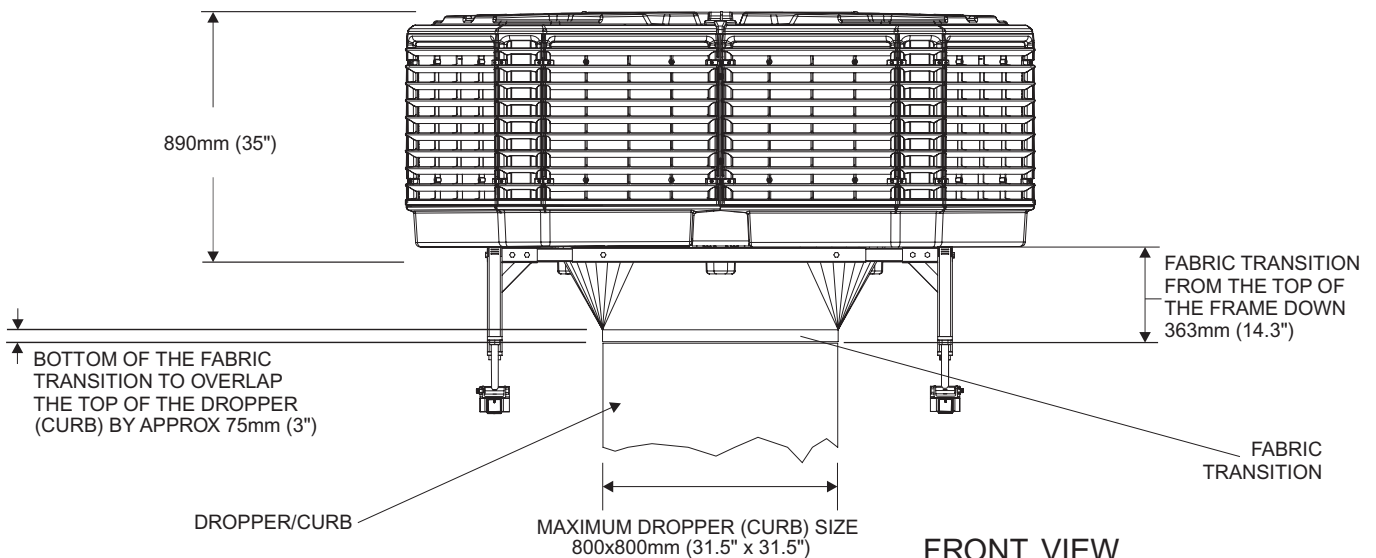

ILL1687-A

ENV1000 COOLER SPECIFICATIONS

Airflow	L/sec @ 80Pa (cfm @ 0.3 IWG)	9,140 l/sec (19,540cfm)
Power Supply (Europe, Australia)	Voltage/Phases/Hz (Europe Aust)	400V - 415V / 3~ / 50Hz
	Rated Current (Amp)	8.5A (3~, 415V)
Power Supply (USA)	Voltage/Phases/Hz (USA)	440V - 480V / 3~ / 60Hz
	Rated Current MCA (Amp)	11.25A / phase
	MOPD (amp)	15A
Controller	Type	Variable speed
Fan x 3	Type	Axial
Motor x 3	Type	Inverter - Variable speed
	Speed max. RPM	1,600 RPM
	Power	1,500W each motor
	Current	2.8A
	Voltage/Phases/Hz	380V - 480V / 3~ / 50-60Hz
	Overloads	Auto-reset and "One Shot"
Pump x 3	Type	Centrifugal
	Motor	Synchronous
	Rating Watts input/motor	25W each pump
	Flow Rate l/min (gallons/min)	21 l/min (5.5 gallons/min)
	Voltage/Phases/Hz	220V - 240V / 1~ / 50Hz (Eur/Aus) 60Hz (USA)
Cooling Pad Chillcel	Size mm (inches)	593 (23.5") x 950 (37.5") x 100mm (4.0") (9 Pads)
	Pad Area m ² (square feet)	5.1m ² (55ft ²)
Water	Tank capacity Litres (gallons)	48 Litres (13 gallons)
	Water Inlet (inches)	1/2" male BSP
Drain Valve	Voltage	12V
	mm (inches)	40mm (1 1/2") male
Shipping	Dimensions max. mm (inches)	1,935 (76") x 2,150 (85") x 1,275mm (50") (H)
	Mass kg (lb)	240 kg (529lb)
	Operating kg (lb)	315 kg (695lb) (water tanks full)
Connecting Duct	Length & Width mm (inches)	800mm (31.5") x 800mm (31.5")

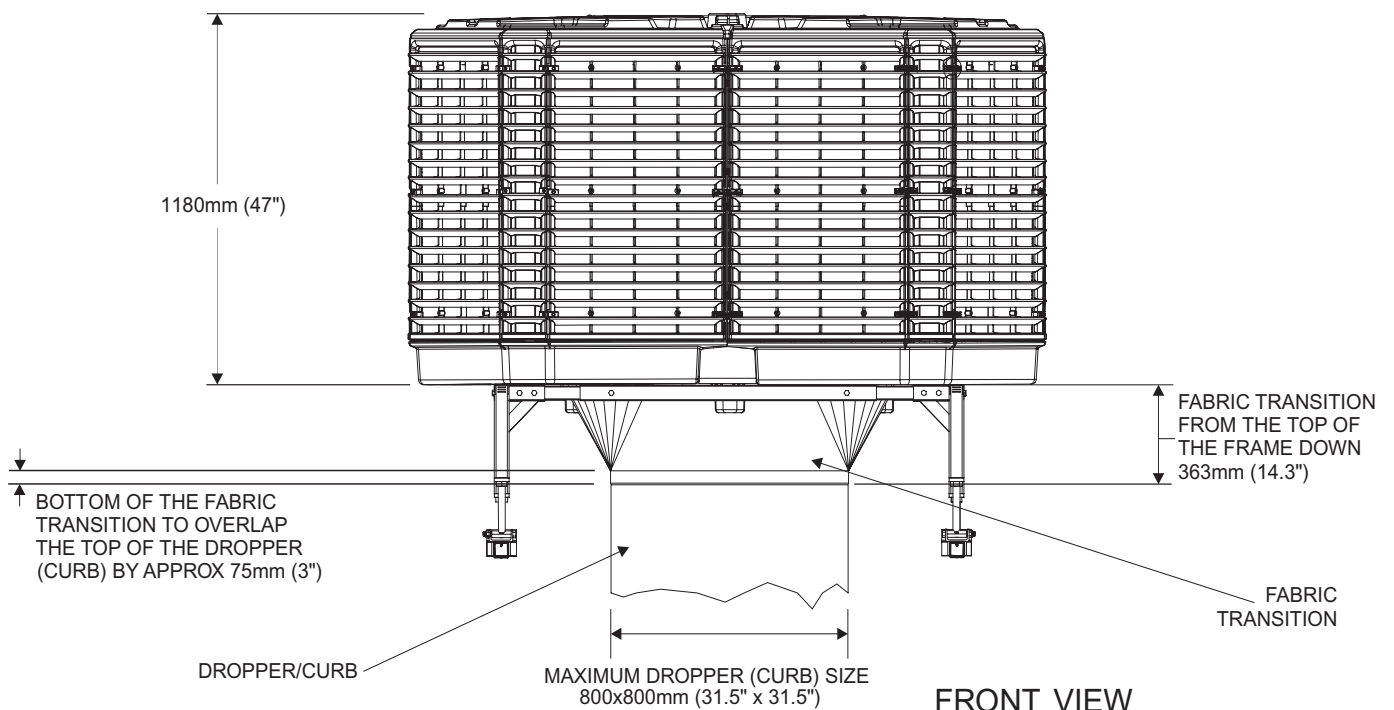

ILL2283-A

GENERIC COOLER SPECIFICATIONS

TOP VIEW

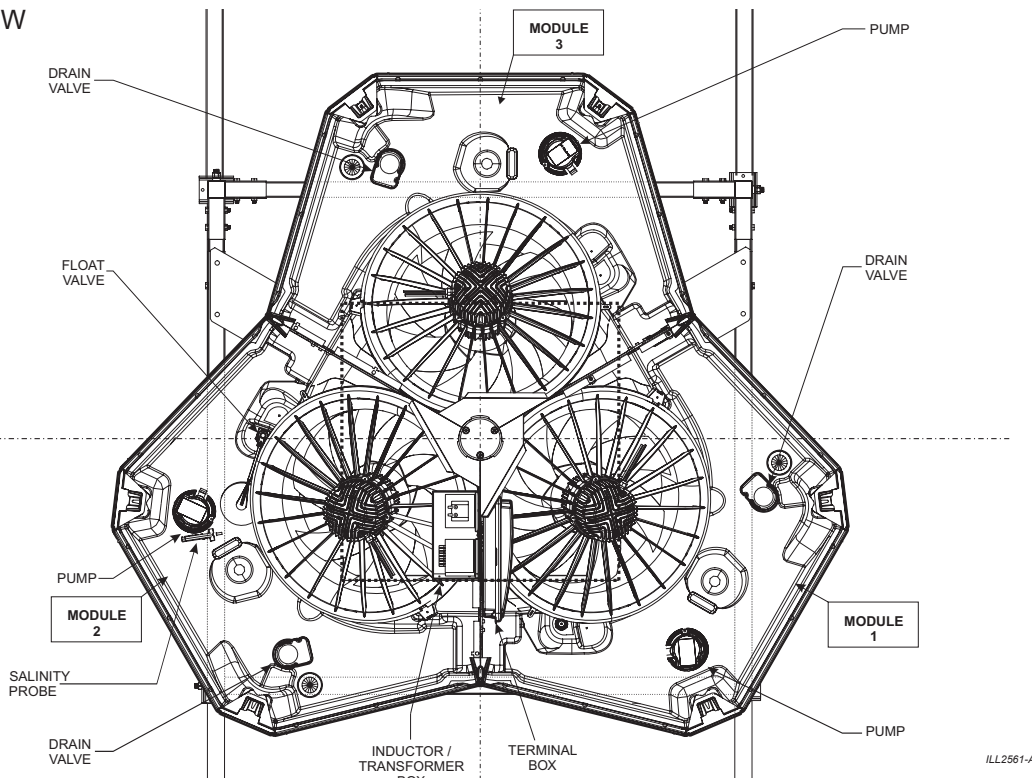

ILL2561-A

TOP VIEW

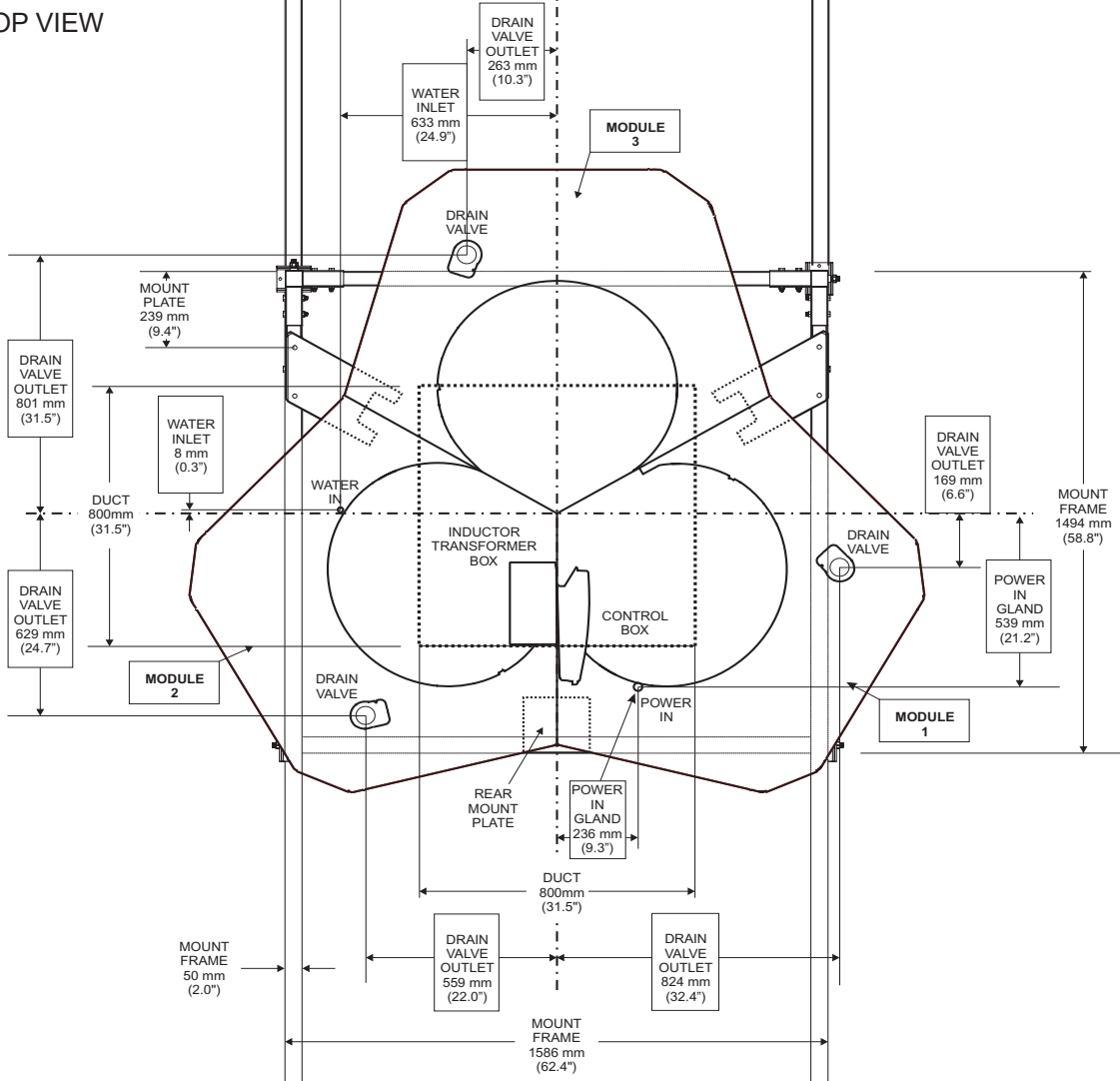

ILL2199-A

COOLER CONTENTS

ITEM	DESCRIPTION	QTY
1	WALL CONTROL CABLE 40m (131ft)	1
2	MAGIQCOOL WALL CONTROL	1
2A	MAGIQTOUCH WALL CONTROL	
3	SCREWS (Wall Control Mount)	2
4	WALL PLUG (Wall Control Mount)	2
5	SCREWS 14G (Cooler Mounting Plates)	12
6	COOLER MOUNT PLATES LHS & RHS	2
7	COOLER MOUNT PLATE - REAR	1
8	DUCT ATTACHMENT CHANNELS	4
9	WATER INLET SOLENOID	1
10	SOLENOID COVER	1
11	FLEXIBLE WATER INLET HOSE	1
12	NUT & OLIVE 1/2" BSP	1
13	INSTALLATION MANUAL	1

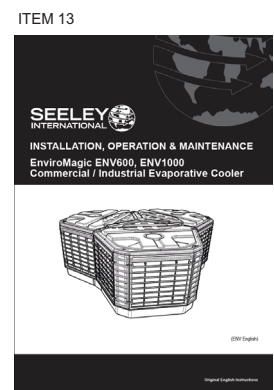
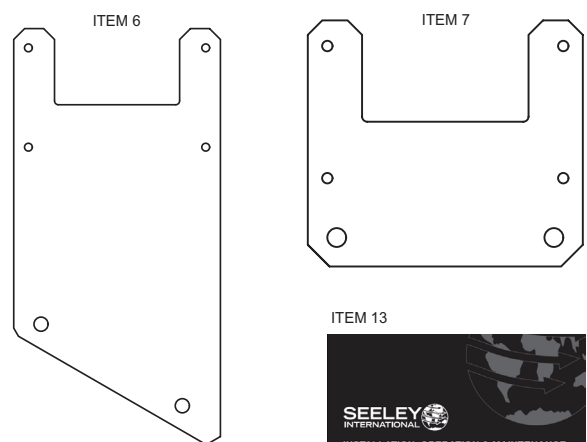
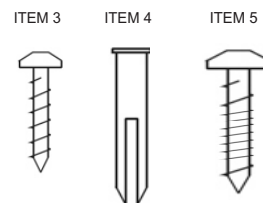
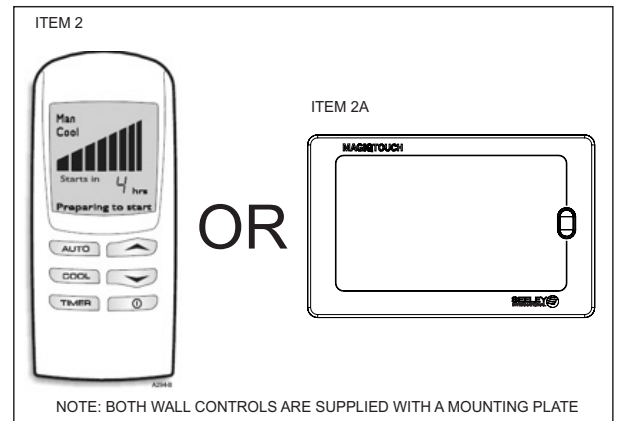
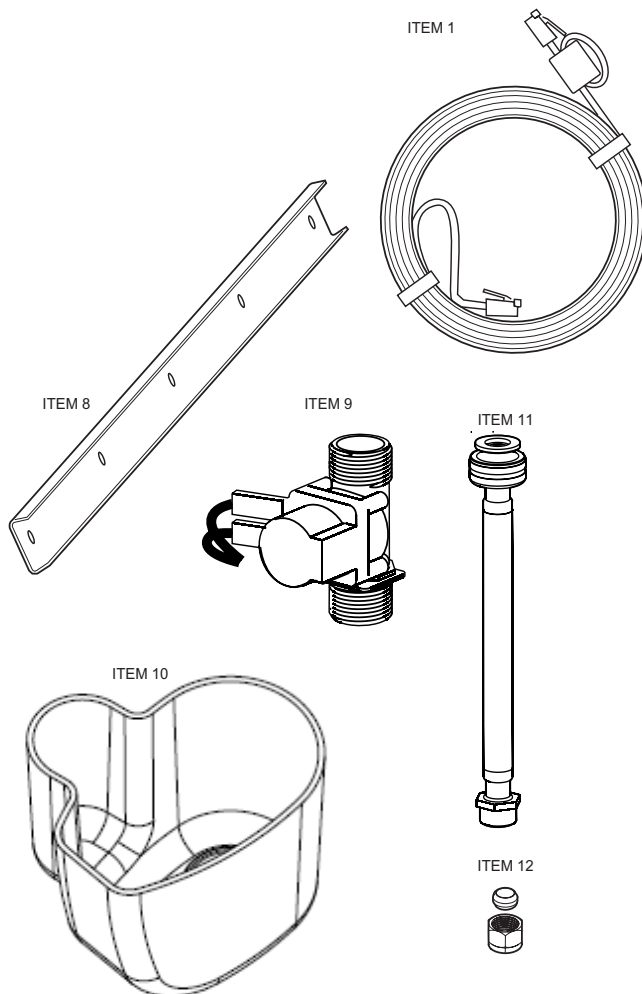

QUICK GUIDE

STEP 1

SAFETY

Read & understand the safety section.



page 4

STEP 2

REGULATIONS

Read & adhere to the local & national electrical and plumbing regulations.

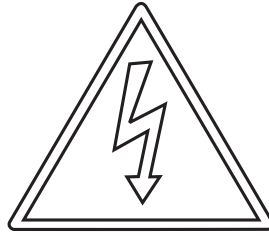

page 5

STEP 3

COOLER LOCATION

Check cooler location. Consider regulations. Discuss with customer.

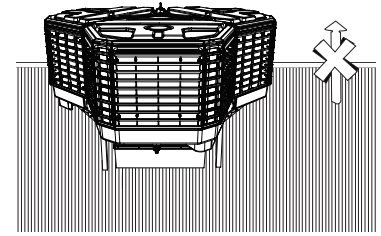

page 12

STEP 4

PREPARE INSTALL AREA

Cut hole in roof. Consider safe access to cooler (platform, walkways etc)

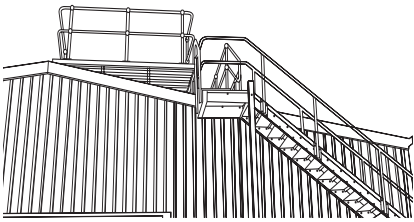

page 12

STEP 5

COOLER SERVICES

Prepare mains power cables, water supply & gravity feed waste water piping in close proximity to the installation dropper site.

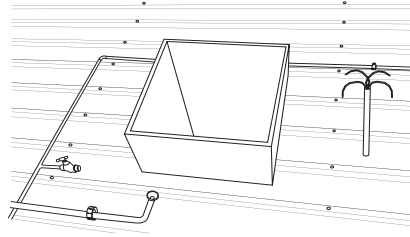

page 13

STEP 6

MOUNT DROPPER

Position, level, secure and flash the dropper. Install cooler mounting frame.

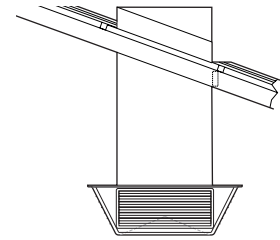

page 13

STEP 7

CONVEY COOLER

Convey the cooler to the roof. **Note!** Always use at least 3 people if handling manually.

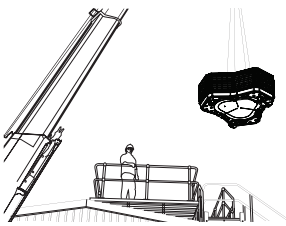

page 12

STEP 8

MOUNT COOLER

Mount cooler to the support frame / dropper. **NOTE: Check tank is level.**

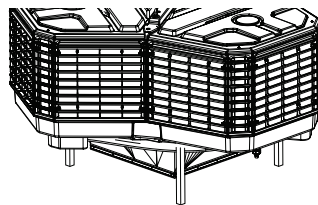

page 14

STEP 9

CONNECT SUPPLY DUCTING

Connect the fabric transition from cooler to supply duct/dropper/curb.



page 14

STEP 10

CONNECT DRAIN PIPES

Drain Valves are factory fitted. Connect the discharge piping to the Drain Valve assembly.

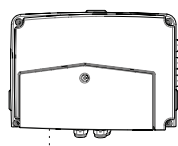

WALL CONTROL STANDARD INSTALLATION
40m (131') SUPPLIED WITH COOLER
MAX 40m (131')

page 15

STEP 11

CONTROLLER CABLE

Connect one end of the controller cable to cooler electronics box.



page 19

STEP 12

FIT INLET SOLENOID

Connect water supply.

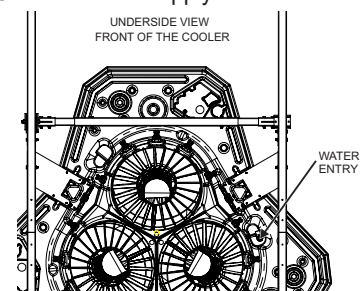

page 18

QUICK GUIDE

STEP 13

INSTALL CONTROLLER

Mount controller in required location.



page 21

STEP 14

COMMISSION COOLER

Test the cooler with the controller.
Check diagnostics of cooler electronics.

page 21

STEP 15

TEST DRAIN OPERATION

Test drain valve.

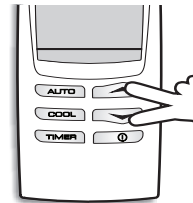

page 21

STEP 16

REFIT PAD FRAMES

Ensure cooler lid is screwed closed after re-fitting pad frames

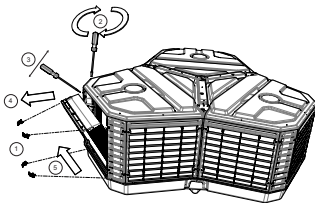

page 13

STEP 17

TEST PUMP

Turn on cooler and check water is evenly distributed to all pads. Fill the tanks and switch fans off to check water level is even in all 3 tanks, confirming the cooler is level.

page 21

STEP 18

COOLER PARAMETERS

Where necessary, adjust cooler settings to suit customer requirements using the controller.

page 22

STEP 19

FINAL CHECK

Test & complete commissioning checklist at the end of this document.



page 28

STEP 20

CLEAN UP

Clean up the site!

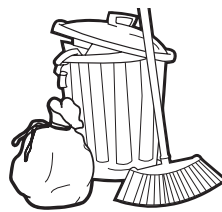

page 28

STEP 21

CUSTOMER HANDOVER

Show customer how to operate cooler.
Give them the cooler manual.
Explain maintenance requirements.



page 28

INSTALLATION

LOCATION REQUIREMENTS

Check the proposed cooler location to ensure that it is structurally capable of supporting the weight of the cooler or provide an adequate alternate load bearing structure.

Model	Shipping Weight	Operating Weight (water tanks full)
ENV600	190kg (419 LB)	265kg (584 LB)
ENV1000	240kg (529 LB)	315kg (695 LB)

Always locate the cooler where it will receive a plentiful supply of fresh air, NOT in a recess where it may be starved for air or where the air is polluted.

Ensure the location is a minimum of:

- 3.0m (10') from a solid fuel heater flue,
- 1.5m (5') from a gas flue,
- 5.0m (16') from a sewer vent
- 1.0m (3.5') from walls.

Access should be provided to the underside of the cooler during installation.

Allow adequate access to and around the cooler for maintenance. Provision must be made for access to electricity, water supplies and drains.

Note: Do you need to discuss the installation of items like safety anchor points or access walkways with the customer?

Carefully consider noise levels when locating the cooler, if necessary talk to the customer and the neighbour before carrying out the installation to determine the best location.

MOVING THE COOLER

The cooler has in-built feet to allow forklift access for ease of handling and movement. When moving the cooler with a forklift, locate the fork tynes into the concave cooler section as shown.

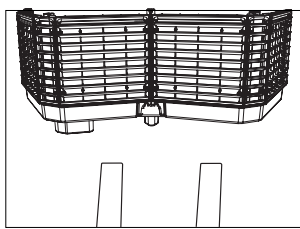

Moving the cooler

Forklift tine orientation when moving the cooler

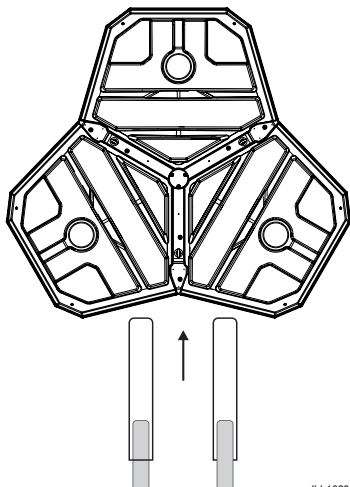

ILL1689-A

REMOVING THE COOLER FROM A CONTAINER

When removing the cooler from a container, tine extensions (slippers) may be required to prevent the cooler from over-balancing.

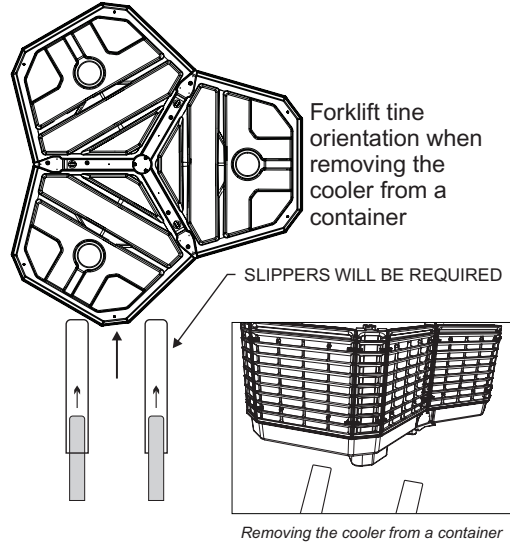

Removing the cooler from a container

ILL2239-A

LIFTING THE COOLER

The cooler should only be lifted fully assembled using the lifting lugs.

Do not attempt to lift using any other cabinet features, as the cabinet may be damaged and/or lift safety compromised.

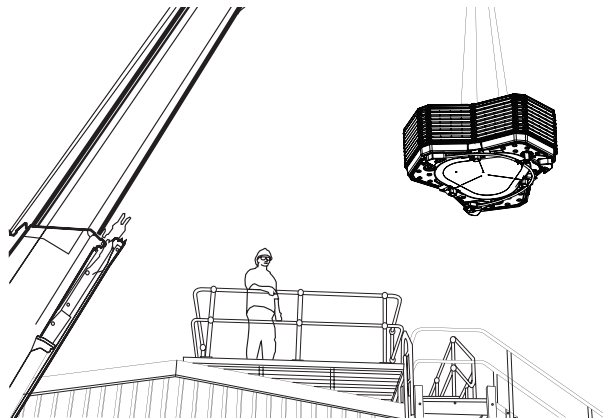

ILL1717-A

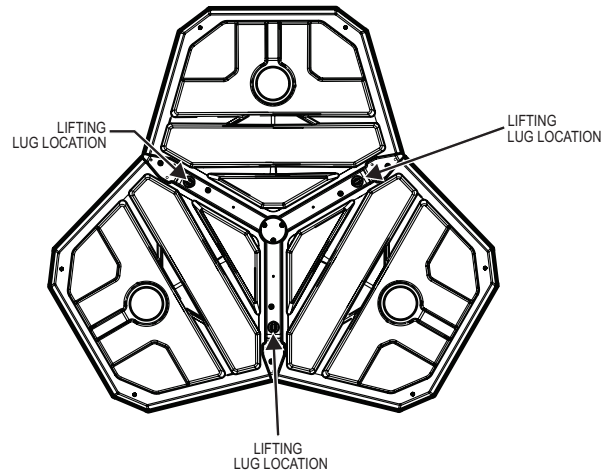

LIFTING LUG LOCATION

ILL1690-A

INSTALLATION

UNPACKING THE COOLER

The cooler will be delivered wrapped in a plastic stretchwrap film which will need to be removed before installation. Installation components can be found inside the cooler.

NOTE: Remove the protection plate from the underside of the cooler before operating the cooler. Refer page 14.

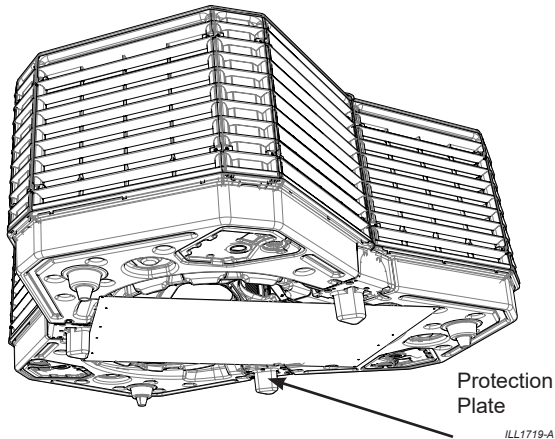

REMOVING PAD FRAMES

STEP 1. Remove clips that fasten the pad frame to the corner pillars, the clips may require a screwdriver to aid removal. Note the difference in shape between the standard external corner clips compared to the internal corner clips. (figs. a & b)

STEP 2. Remove the perimeter lid screws retaining the cooler lid, to allow the lid to be raised to release the pad frame. (fig. a)

STEP 3. Insert a screwdriver into the gap at the top of the pad frame in order to raise the lid until the top edge of the pad frame disengages.

STEP 4. Pivot the frame outwards. **RAISE THE LID CLEAR OF THE PAD FRAME AS IT IS REMOVED TO PREVENT DAMAGE TO THE PAD.**

STEP 5. The frame is now free to be lifted out of the cooler cabinet.

fig. a

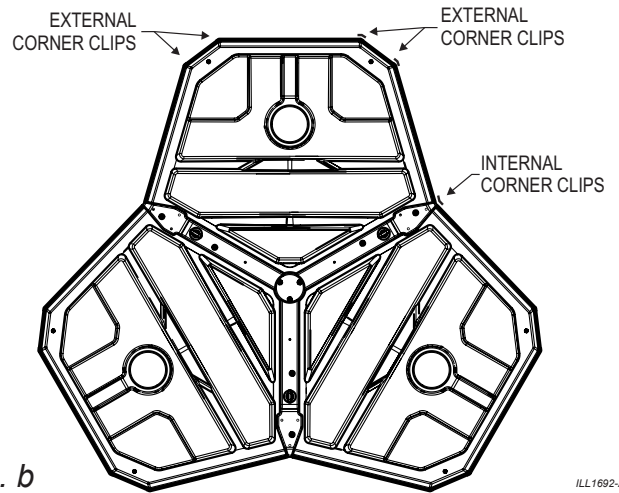
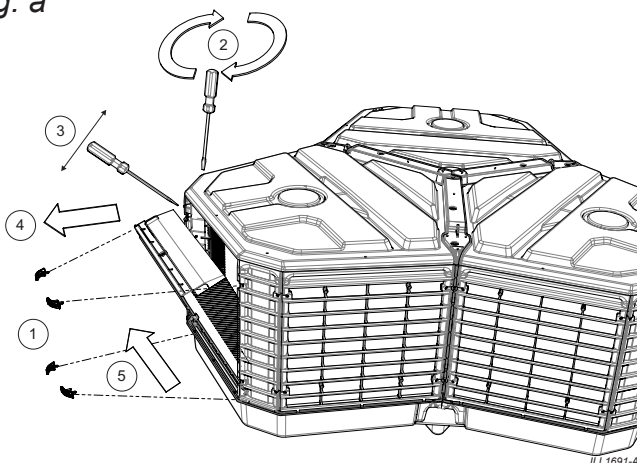
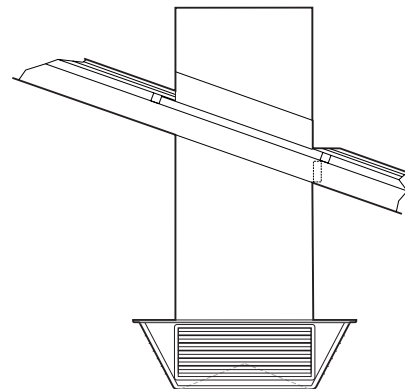

fig. b

MOUNTING THE DROPPER/CURB

An appropriate dropper/curb needs to be fabricated and installed on the roof to mount the cooler. **The design of the dropper is the responsibility of the Installer.**



COOLER SERVICES

Power, water and drainage provisions need to be provided to the cooler. Refer to Local Regulations regarding specifications required for each. **The design of the service provisions is the responsibility of the Installer.**

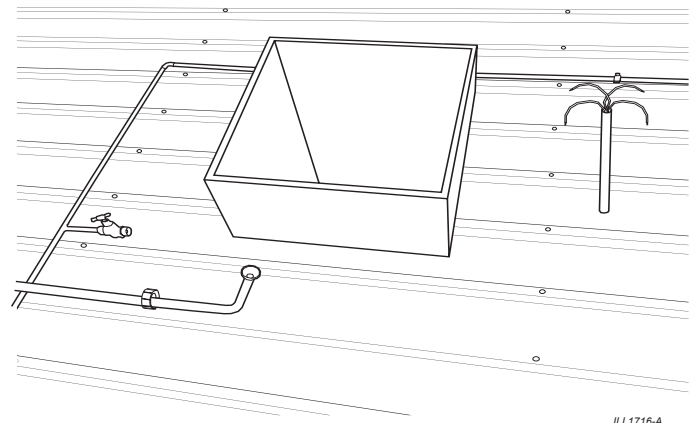

INSTALLATION

MOUNTING THE COOLER

An appropriate mounting frame needs to be fabricated to mount the cooler.

The design of the mounting frame is the responsibility of the Installer.

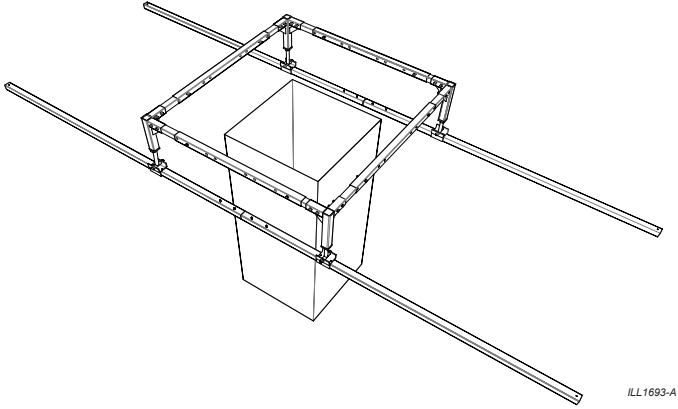

ILL1693-A

VIBRATION ISOLATION

Use industry standard methods for fixing the frame to the building structure. Vibration Isolation pads are recommended to be used under the frame.

FIXING THE COOLER TO THE MOUNTING FRAME

Use the 3 mounting plates (supplied) to attach the cooler to the mounting frame. Each mounting plate requires 4 screws to be fitted to the cooler.

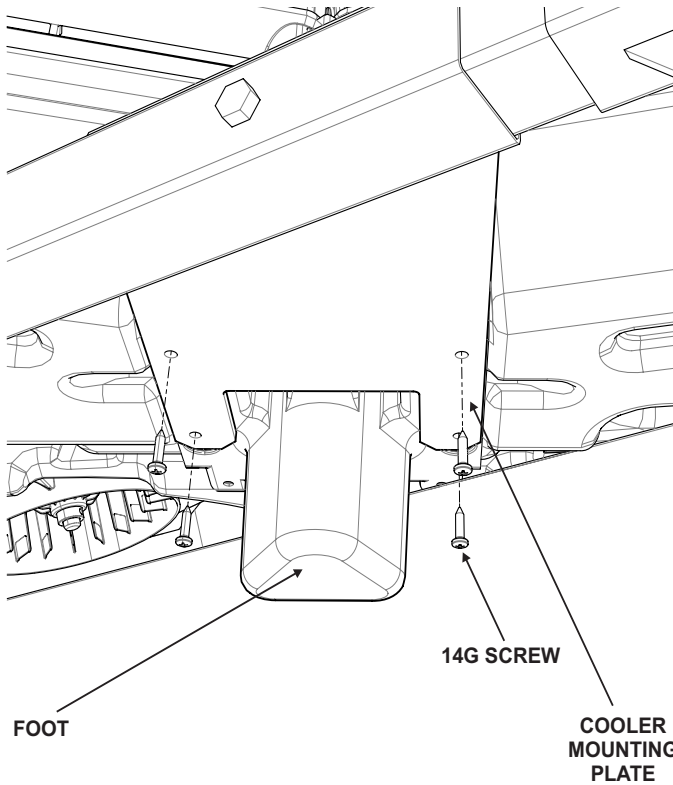

ILL1694-A

REMOVING THE TRANSPORT PROTECTION PLATE

After placing the cooler onto the frame, the transport protection plate can be removed.

Unfasten the attachment screws and slide the plate free from the cooler.

Do not invert or tip the cooler onto its side to remove the plate, as internal components may be dislodged or damaged.

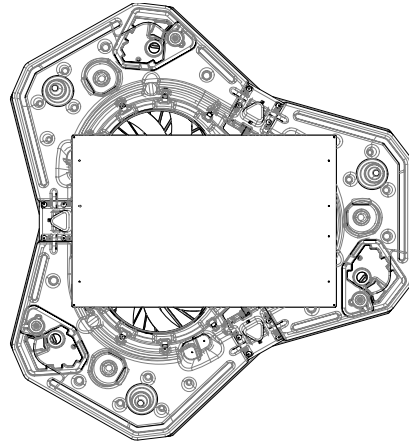

ILL1695-A

FLEXIBLE DUCT FITTING

Once the transport protection plate has been removed the flexible duct transition can be lowered.

Assemble and fix the flexible duct transition to the duct dropper using the duct attachment channels (supplied), and self tapping screws (not supplied).

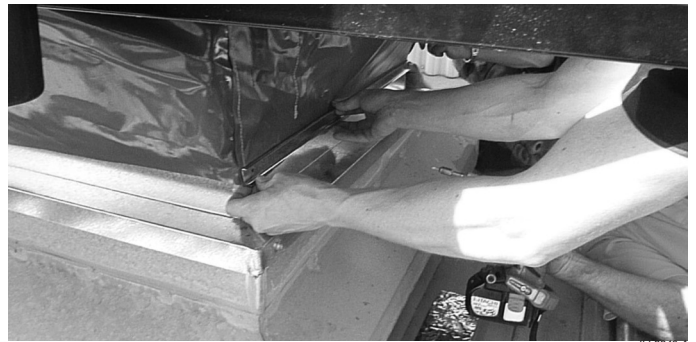

Fit the flexible duct transition to the duct dropper.

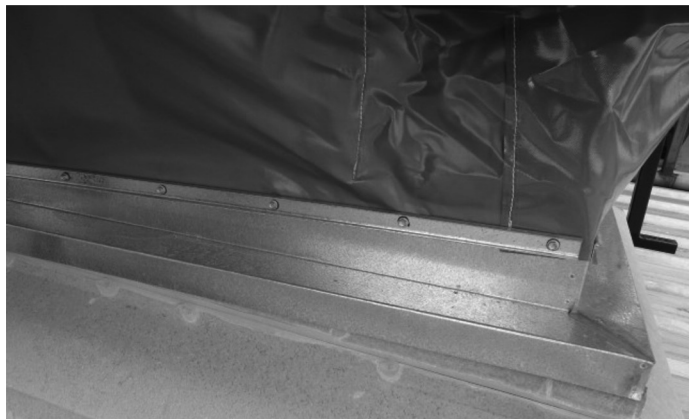

Secure flexible duct with fastening strips and self tapping screws.

INSTALLATION

INSTALLING MAINS AND CONTROL CABLES

Drill 2 separate holes for the power cable and the control cable through the raised section in the base of the tank in Module 1, as indicated in the diagram below.

Hole sizes are to suit the cable/conduit glands to be fitted such that cables are secure and no gaps are present.

Use cable/conduit glands to seal the entry holes. Route the cables from the glands to the adjacent cooler control enclosure.

Minimum cable sizes for fixed wiring:

ENV600 1~: 1.5mm²

ENV600 3~, ENV1000: 1.0mm²

Fixed wiring and cable / conduit glands are to be in accordance with local and national wiring rules.

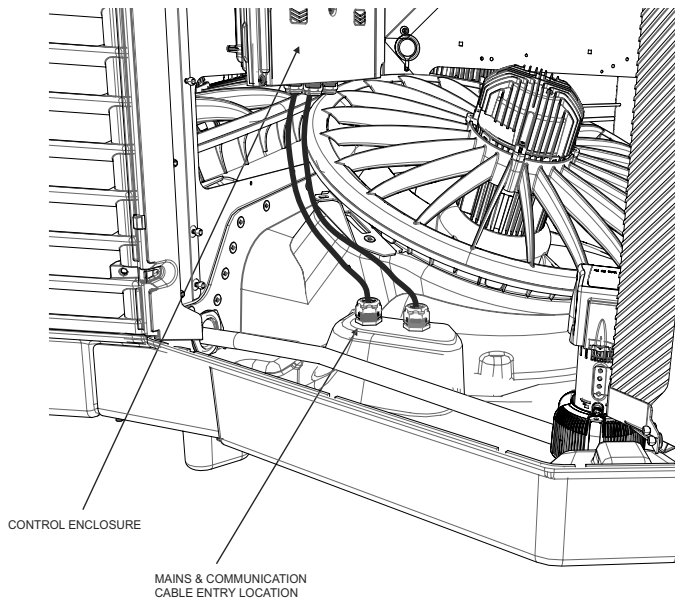

ILL1696-A

CONNECTING THE DRAIN VALVES

Water drained from the drain valves must be carried away to a suitable discharge point on the building or property, in accordance with local regulations. It is a requirement of Seeley to never drain water directly on to the roof. The drain pipe away from the cooler must be gravity fed.

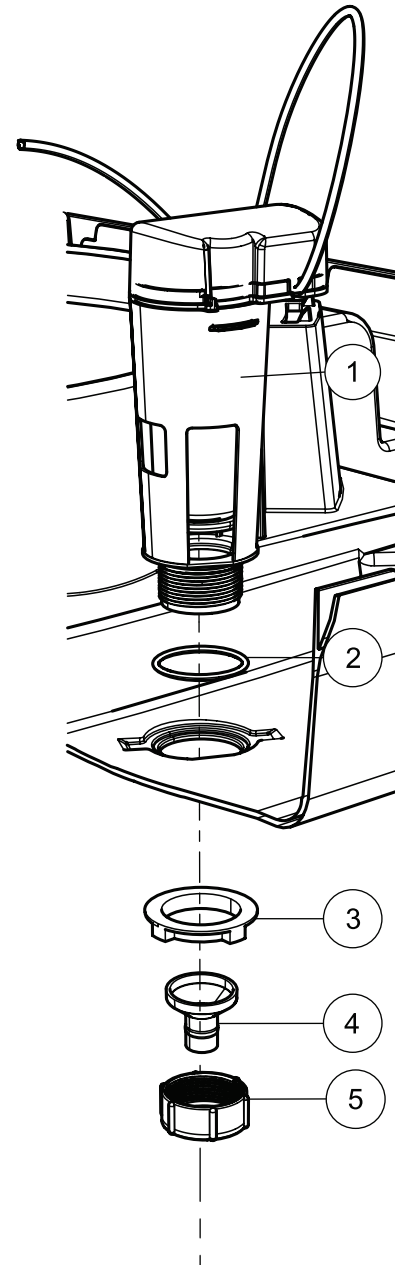

ILL1697-A

INSTALLATION

ELECTRICAL SUPPLY INSTALLATION WIRING ENV600

Both the enclosure cover and the lid of the control enclosure will need to be removed in order to gain access for wiring mains supply. Feed the power supply cable through the larger gland and connect to the terminal block. Installation of the cooler must conform to local electrical rules, regulations and standards and the National Electric Code.

It is a requirement of Seeley International that all coolers be wired with a dedicated circuit to the distribution board and also fitted with an all pole disconnection switch in the fixed wiring in accordance with local wiring rules.

The switch should be located in a position that is easily accessible and visible when servicing the cooler.

ENV600 coolers are wired as 3-phase ex-factory. In Australia/Europe if single phase connection is required, revise the wires between the mains power field terminals to the contactor terminals (2, 4, 6) so they connect to the common "L" mains terminal. This is shown on the single phase wiring diagram adjacent and attached to the lid.

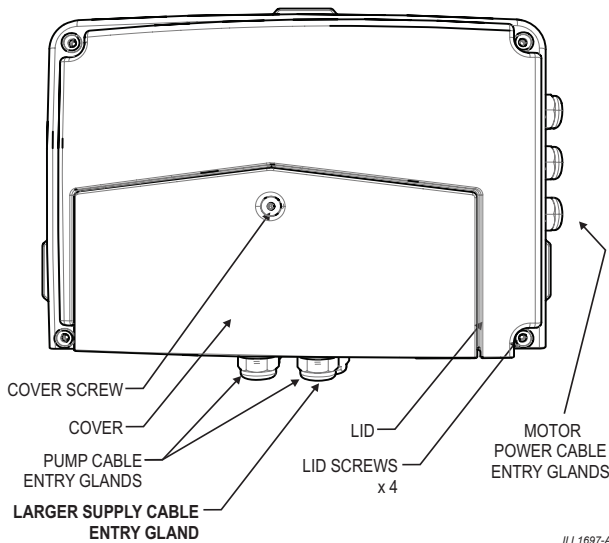

ILL1697-A

USA ENV600 WIRING DIAGRAM

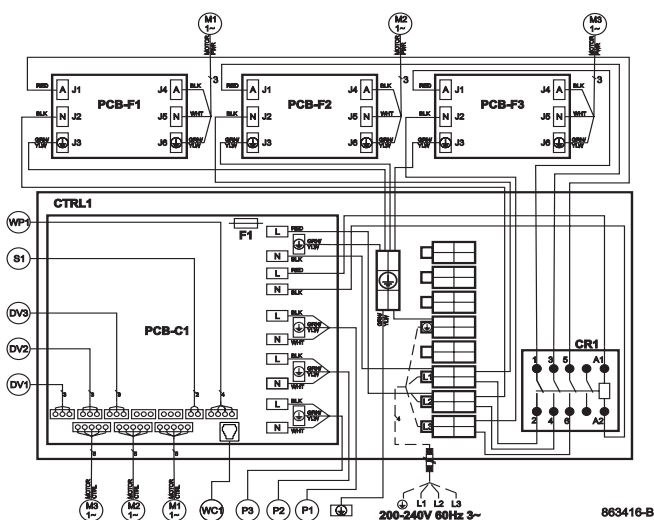

863416-B

EUR/AUST ENV600 WIRING DIAGRAM

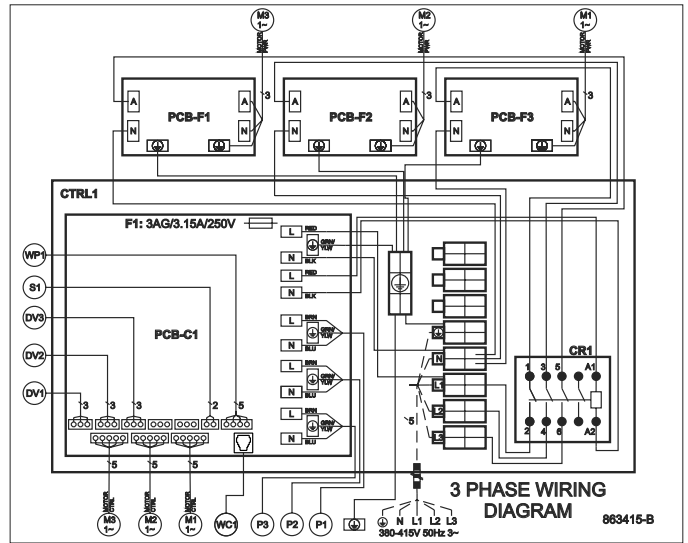

863415-B

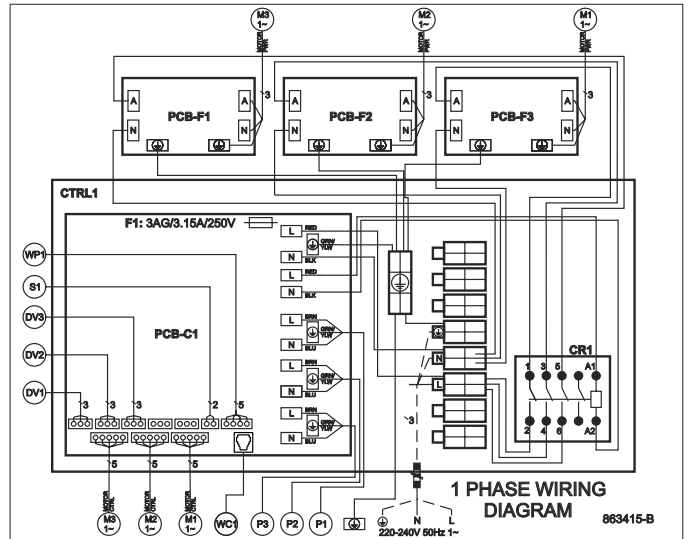

863415-B

Components	
CR1	Contactar
CTRL1	Control Box Enclosure
DV1	Drain Valve 1
DV2	Drain Valve 2
DV3	Drain Valve 3
F1	Fuse - 3AG 3.15A/250V
M1	Motor 1 - Single Phase
M2	Motor 2 - Single Phase
M3	Motor 3 - Single Phase
P1	Pump 1
P2	Pump 2
P3	Pump 3
PCB-C1	Printed Circuit Board - Main Control
PCB-F1	Printed Circuit Board - Filter 1
PCB-F2	Printed Circuit Board - Filter 2
PCB-F3	Printed Circuit Board - Filter 3
S1	Solenoid
WC1	Wall Control
WP1	Water Probe

Legend	
	Field Wiring
	Earth
L, A	Live/Active
N	Neutral
	Terminal

Lead Colours	
BLK	Black
BLU	Blue
BRN	Brown
GRN	Green
RED	Red
YLW	Yellow

863415-B

INSTALLATION

ELECTRICAL SUPPLY INSTALLATION WIRING ENV1000

Both the enclosure cover and the lid of the control enclosure will need to be removed in order to gain access for wiring mains supply. Feed the power supply cable through the larger gland and connect to the terminal block. Installation of the cooler must conform to local electrical rules, regulations and standards and the National Electric Code.

It is a requirement of Seeley International that all coolers be wired with a dedicated circuit to the distribution board and also fitted with an all pole disconnection switch in the fixed wiring in accordance with local wiring rules.

The switch should be located in a position that is easily accessible and visible when servicing the cooler.

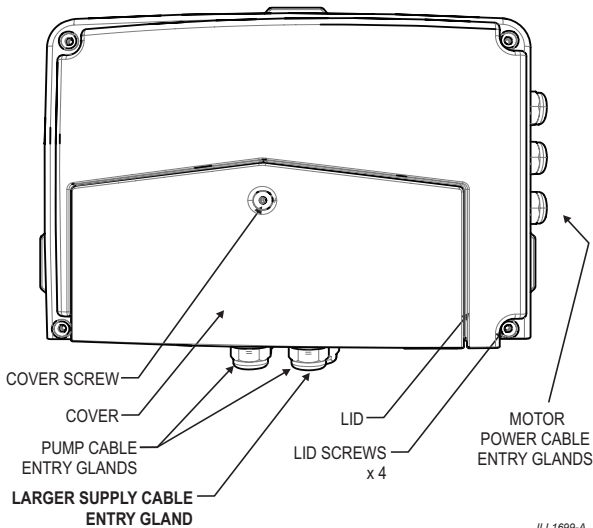

EUR/AUST ENV1000 WIRING DIAGRAM

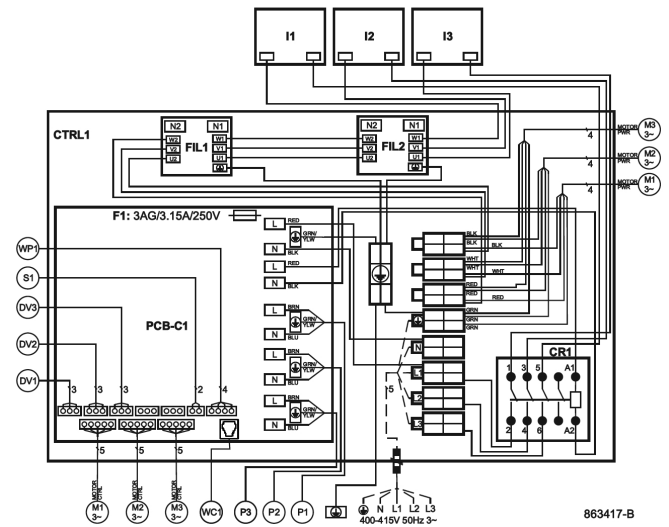

Components	
CR1	Contactors
CTRL1	Control Box Enclosure
DV1	Drain Valve 1
DV2	Drain Valve 2
DV3	Drain Valve 3
F1	Fuse - 3AG 3.15A/250V
FIL1	Filter 1 - EMI 3 Phase
FIL2	Filter 2 - EMI 3 Phase
I1	Inductor 1
I2	Inductor 2
I3	Inductor 3
M1	Motor 1 - 3 Phase
M2	Motor 2 - 3 Phase
M3	Motor 3 - 3 Phase
P1	Pump 1
P2	Pump 2
P3	Pump 3
PCB-C1	Printed Circuit Board - Main Control
S1	Solenoid
WC1	Wall Control
WP1	Water Probe

Legend	
	Field Wiring
	Earth
L, A	Live/Active
N	Neutral
	Terminal

Lead Colours	
BLK	Black
BLU	Blue
BRN	Brown
GRN	Green
RED	Red
WHT	White
YLW	Yellow

USA ENV1000 WIRING DIAGRAM

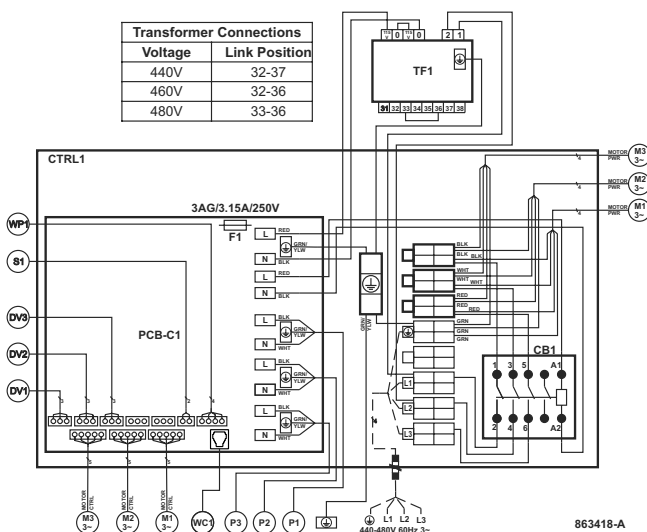

TRANSFORMER ADJUSTMENTS (USA ENV1000 ONLY)

A transformer is used to generate 230V supply for the main PCB and pumps. Depending on the 3 phase supply voltage the transformer wiring may need to be adjusted to suit.

A suitable link must be placed across the terminals indicated to suit the incoming supply voltage. The cooler is supplied with a link across terminals 33 - 36 for a 480V supply. This will need to be adjusted to suit different supply voltages.

3 phase supply voltage	Link Position
440V	32-37
460V	32-36
480V	33-36

INSTALLATION

WATER SUPPLY INSTALLATION

Installation of the water supply to the cooler must conform to local plumbing rules, regulations and standards. The connection point is located in Module 2, please refer to the schematic below.

The following specifications for water supply are required:

- Water Connections: **1/2" Copper Tube.**
- Water Supply Pressure: **100kPa (15psi) - 800 kPa (115psi) MAXIMUM**
- Water Supply Flow: **20L/min (5.3 gal/min) MINIMUM**
- Water Supply Temperature: **40°C (105°F) MAXIMUM**

Important! New hose sets supplied with the appliance are to be used. Old hose sets (from previous installations) should not be re-used.

Important! If the water pressure exceeds the maximum specification then a pressure reducing valve is required and must be supplied and fitted by the installer.

The installer must provide a manual 1/4 turn ball type shut off valve (do not use a stop cock) in the water supply line adjacent to the cooler, subject to local plumbing regulations. This allows the water supply to be isolated whenever work needs to be performed on the cooler.

In areas subject to freezing, the water line needs a drain down facility.

Important! Flush the water pipe to remove any swarf before final fitting. Swarf can lodge in the solenoid, preventing it from functioning correctly.

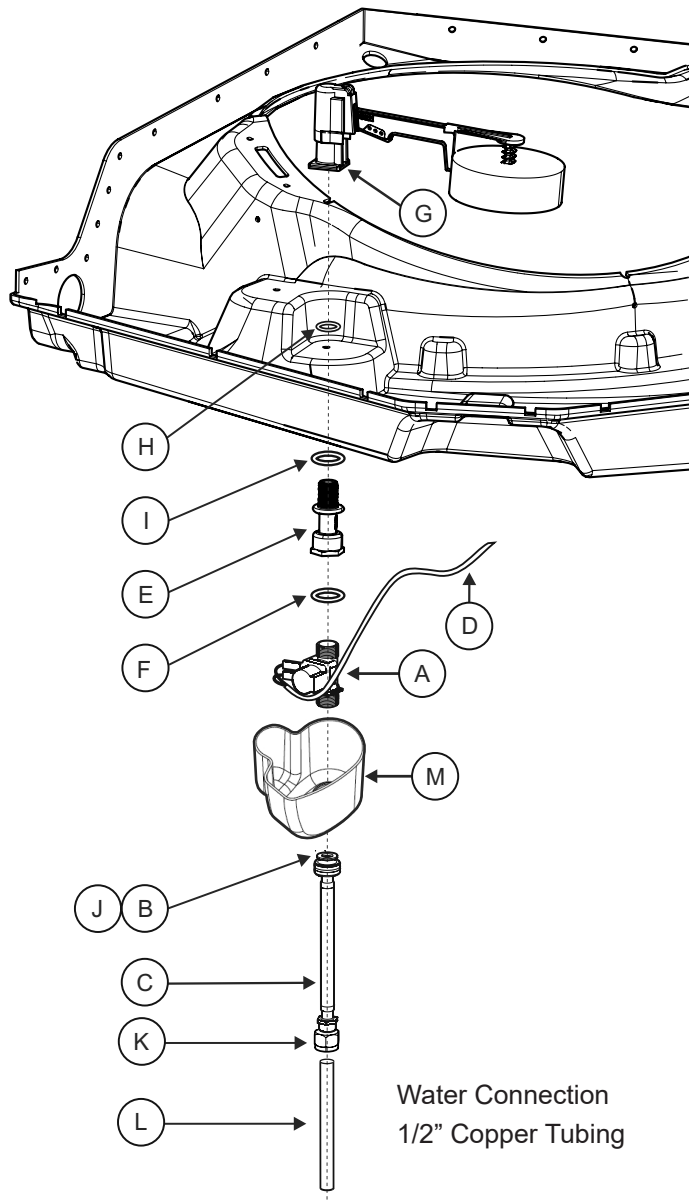

Water Connection
1/2" Copper Tubing

- A Solenoid
- B Nut (connects flexible hose to Solenoid)
- C Flexible hose assembly
- D Solenoid power leads
- E Extension Tube
- F Washer
- G Float Valve Assembly
- H O Ring
- I O Ring
- J Washer (supplied with flexible hose)
- K Nut 1/2" BSP & Olive
- L Copper Tubing 1/2"
- M Solenoid Cover

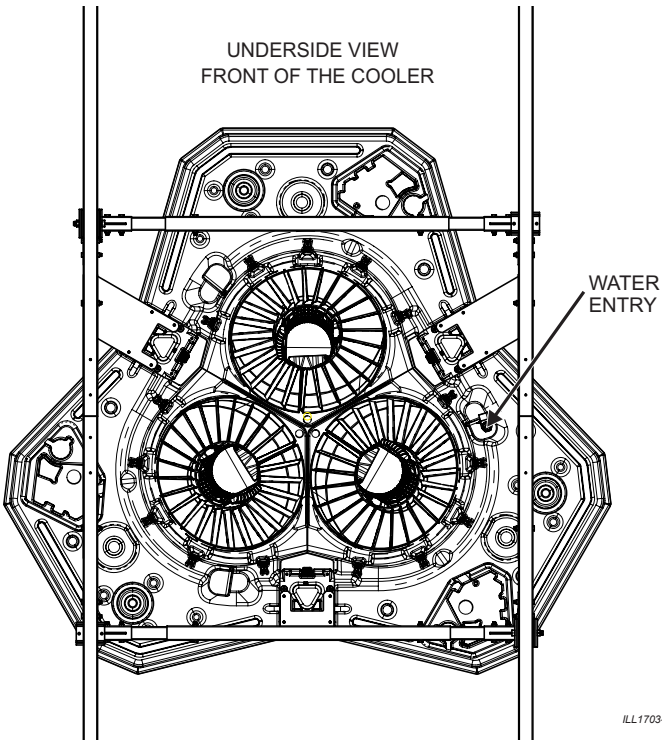

ILL1703-A

ILL2243-A

INSTALLATION

CONTROL SYSTEM

EnviroMagic coolers are supplied from the factory with a Wall Control and a 40m (131') control cable. This makes it possible for the cooler to be controlled independently and automatically from the zone to which it is delivering cool air. The Wall Control incorporates a thermostat that regulates fan speed to try and maintain indoor temperature within $\pm 1^{\circ}\text{C}$ ($\pm 3^{\circ}\text{F}$) of the set temperature.

WALL CONTROL CABLE WIRING

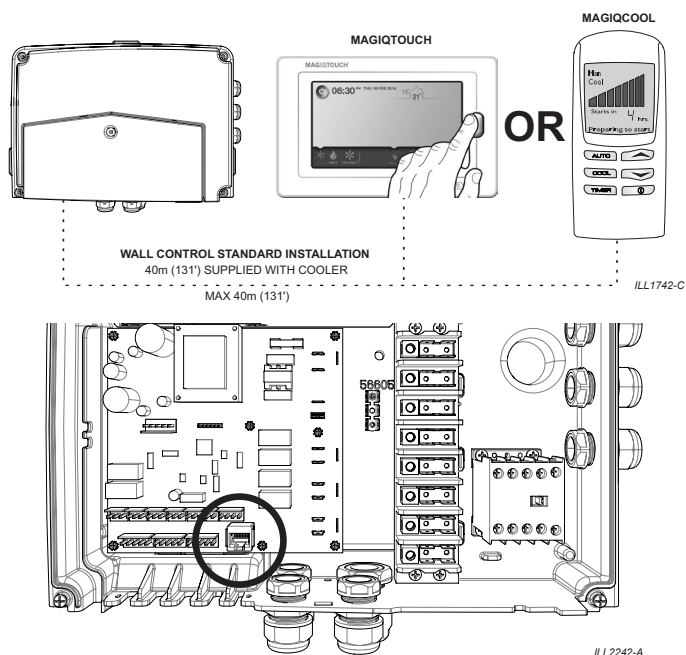

IMPORTANT REMINDER! Do not route the wall control cable over supply mains cables without first consulting your local wiring standards. Routing the wall control with power supply cable in close proximity can present an electrical hazard and can be detrimental to the performance of the product, resulting in intermittent communication errors and inconsistent or erratic operation.

Seeley International recommends:

- Not to route the wall control and power supply cables in the same conduit.
- Not to cable tie or tape the wall control and power supply cables together.
- A minimum separation distance, as specified by local wiring standards, between the wall control and power supply cables. In Australia, the minimum separation distance is 50mm (2").

RUNNING THE CONTROL CABLE TO THE WALL CONTROL

Using the loop on the end, draw the cable through the wall cavity to the hole made at the wall bracket. Carefully remove the tape from the cable loops and check that the plug has not been damaged. Connect the cable to the wall control and mount the wall control onto its bracket.

Important! Take care not to damage the cable or plug during this process. Always seal the cable entry hole.

LOCATING THE WALL CONTROL

The wall control should be placed approximately 1.5 m (5') above the floor, in the general area of the cooled zone.

Placement of the Wall Control is critical for correct functioning of the in-built thermostat (incorporated in the wall control). The following points must be taken into consideration:

- Avoid direct sunlight exposure.
- Avoid mounting on external walls.
- Avoid mounting the wall control near heat sources such as room heaters, stoves and TV's.
- Do not locate in the direct airflow from the duct outlets.
- Do not locate in strong drafts or in dead spots such as corners and confined spaces.
- Always seal the cable entry hole in the wall. Hot air coming through the wall may interfere with the temperature measurement.



CAUTION! Always make sure there are no electrical cables, gas or water pipes, or the like, behind where you intend to drill.

INSTALLATION

MAGIQTOUCH CONTROLLER OPERATION



ILL1582-A

Refer to the Owner's Manual supplied with the controller for detailed operating instructions.

Your MagIQtouch Controller contains a settings menu, which gives you access to information about your evaporative cooler and to extra functions including:

About Appliance

Access information about the appliances installed in your system.

Min/Max Set Temperature

You can change the minimum and maximum temperature displayed on your slider, depending on what temperature range you prefer your system to work within.

Night Quiet Mode

Restrict fan speed over the night time period for a quiet night's sleep.

Manual Drain

This will turn the cooler off and drain the tank.

Pad Flush

This will turn the cooler off and run the pumps for a specified time. Use this feature to flush the cooler pads.

Drain and Dry

This option allows you to nominate a time each day when the cooler will drain the tank and run the fan for 1 hour.

Autoclean

Select the preferred cleaning interval (50 / 100 / 200 hrs). At 8.00am after the selected running hours has been reached, the cooler will drain the tank, fill with fresh water and operate the pump for 5 minutes. When complete, drains the tank and returns to previous operation mode.

External Sensor

EnviroMagic coolers can be fitted with an optional external air sensor. When switched on, it displays a live external ambient temperature reading on the wall controller. A desired external temperature set point can be programmed to turn off the pump conserving water usage and reducing humidity while the cooler is running. In addition where climate conditions are close to freezing, an external temperature set point can be programmed to auto drain the tank and prevent freezing conditions damaging the tank.

Note! There are some settings which are locked and are only for installers or service technicians.

MAGIQCOOL CONTROLLER OPERATION



ILL2121-A

MagIQcool Wall Controllers can operate in manual or automatic mode.

MANUAL MODE

Manual mode will allow you to change settings for operating the cooler, such as altering fan speeds, pump control and manual drain control.

AUTO MODE

Auto mode will allow thermostatic control to set temperature targets / operating settings. It has the capability of programming ON/OFF delay times, enabling the cooler to automatically start up or shut down after a specified period of hours.

At all times the MagIQcool Controller will monitor the cooler for faults and report them to the controller's screen for your reference.

INSTALLATION

MOUNTING THE WALL CONTROL

Fixing the wall control bracket to a plasterboard wall

Use the bracket as a template.

1. Drill the 16mm (5/8") hole for the wall control cable
2. Drill the 5mm (3/16") holes for the wall plugs.
3. Insert the wall plugs into the holes. Align and screw the bracket into position using the supplied screws.

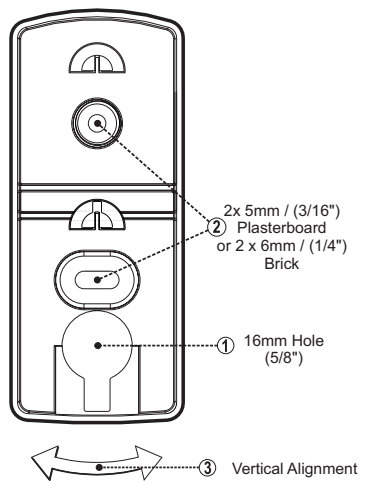

ILL1210-D

Fixing the wall control bracket to a brick wall

1. To mount the wall control bracket on a brick wall, follow the previous instructions using the wall plugs and screws provided.
2. Note that the wall plugs require 6mm (1/4") holes. Mount the wall control following the next procedure.

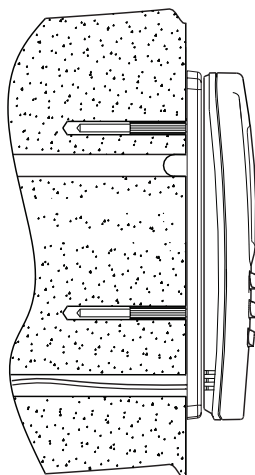

ILL1090-B

Fitting the wall control to the mounting bracket

1. Pull the wall control cable through the larger hole and plug it into the wall control.
2. Feed the excess cable back into the hole and seal. Slide the wall control over the protruding bracket tabs.
3. Pull the wall control down so the bracket tabs engage and locate with the keyway slots on the rear.

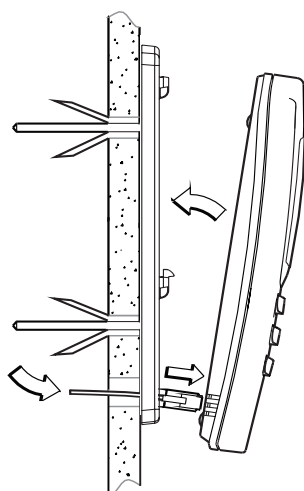

ILL1091-B

TESTING THE COOLER

Once you are satisfied that the Cooler is installed correctly, run the cooler to ensure that everything is working as it should. We recommend that you have a short test lead on hand for Coolers with a hard wired control system. You can then take the wall control to the roof and control the cooler from there.

The short test leads are available from Seeley Spare Parts Distributors
(P/No: 1.5m - 862873).
(P/No: 3.0m - 861265)

TURNING COOLER ON, CHECK FAN OPERATION

Press the "OFF" button to start the cooler. Press the "COOL" button to switch to "Vent" mode which will disable the pumps.

Press the "UP" and "DOWN" buttons to vary the fan speed and check fan operation.

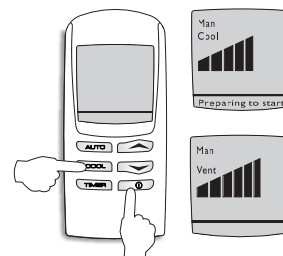

ILL1704-A

CHECKING PUMP OPERATION

Press the "COOL" button to switch to "Cool" mode. With control in "Cool" mode, check the pump function and the start-up sequence. The solenoid will open and water begin to fill the tank. Once water reaches the top probe, the pump will start.

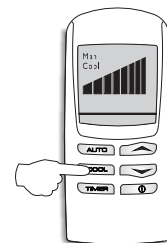

ILL1705-A

CHECKING DRAIN OPERATION

Ensure there are no water leaks. Drain the reservoir by pressing both the "UP" and "DOWN" buttons together, with the wall control in the "OFF" state. Check the drain fittings and pipes, making sure there are no leaks.

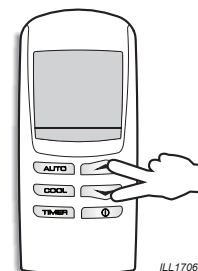

ILL1706-A

INSTALLATION

CONTROL PARAMETERS

A number of Control Parameters can be set to alter the operation of the cooler.

CHANGING CONTROL PARAMETERS

To enter Parameter mode using a Wall Control, the following process must be carried out within Four (4) minutes of mains power being applied to the cooler. If unsure of time since the last Mains Power "ON", remove Mains Power to the cooler (Isolator Switch or Circuit Breaker) for a minimum of six (6) seconds so the mode can be entered.

1. Whilst the wall control is OFF, push and hold "AUTO" for minimum of three (3) seconds. After three (3) seconds whilst still holding "AUTO" button press the "DOWN" button. (If "DOWN" button is pressed before three (3) seconds, nothing will be on the display. If "AUTO" button is continued to be held, subsequent presses of "DOWN" button will allow access).
2. When parameter mode has been entered, the screen will display "A1" and "Param". Pressing "UP" or "DOWN" buttons will scroll through parameters "A1" to "B3" (Refer to table below for factory settings).
3. To view the parameter value set in the wall control press "AUTO" momentarily. Figure "A#" on screen will change to number set, and "Param" will change to "value".
4. To alter the "value" of the selected parameter press "UP" or "DOWN". Numbers will change to show the different values the parameter can be set to.
5. To store the selected value, press "AUTO". The screen will go blank momentarily as the wall control stores the parameter change, and returns the screen to "A#" and "Param".
6. To exit parameter mode or escape from an alteration without storing a change press "0" button instead of "AUTO" button. Remember, once step five (5) has been carried out, new parameter change is permanent until again altered.
7. If no buttons are pushed on wall control, after three (3) minutes the screen will reset to "OFF" state. The procedure to enter parameter mode must be re-initiated.

No.	DESCRIPTION	VALUE
A1	Water salinity control method:	
	- Conductivity measuring	00*
	- Counts low to high probe fills	01
A2	Not applicable to EnviroMagic	
A3	Pre-wet control:	
	- No pre-wet	00
	- Pre-wet	01*
A4	Wall Control back light:	
	- Backlight 'OFF'	00
	- Backlight 'ON'	01*
A5	Conductivity set point:	
	- Normal conductivity - 4275 µS/cm	00*
	- Low conductivity - 2305 µS/cm	01
A6	Tank (reservoir) drain delay:	
	- Instant drain at COOL off	00
	- Drain 3 hours after COOL off	01
	- Drain 12 hours after COOL off	02
	- Drain 3 days after COOL off	03*
A7	Auto re-start after Power failure:	
	- Manual re-start when power OFF	00*
	- Auto restart	01
A8	Temperature units:	
	- Display 0°C	00*
	- Display 0°F	01
AB	Damper Delay	
	- OFF	00*
	- 30 sec	01
	- 60 sec	02
	- 3 mins	03

* = Default Value

OPERATING INSTRUCTIONS

WALL CONTROL

TURNING COOLER ON

The wall control can be switched on and off by pressing the “” button. The wall control will remember the previous setting it was in when the cooler was last used.

PREPARING TO START

Whenever you select AUTO mode, or COOL in MANUAL mode, the cooler will take a few minutes to start as it fills with water and saturates the cooling pads. The time will be decreased if the reservoir is full or the cooler has only recently been turned OFF.

MANUAL MODE

With the wall control switched ON, press the “” button until MAN is shown on the display. (Note: The Wall control display will default to show temperature in deg C (Celsius). If deg F (Fahrenheit) is desired, refer to page 22 for instructions on how to change the A8 Temperature Unit parameter). Although the indoor temperature will be displayed, in manual mode the cooler will not be controlling the temperature.

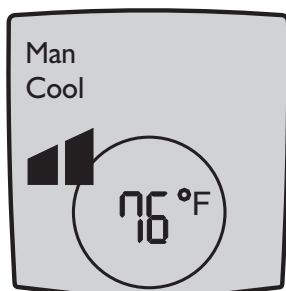
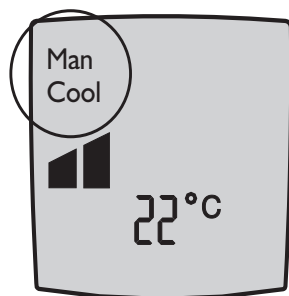



You may then press the “” button to switch between COOL and VENT (VENT = fresh air being delivered but not cooled).

Once COOL or VENT has been selected, the wall control will maintain a constant fan speed. This is indicated by the bar graph shown on the display.

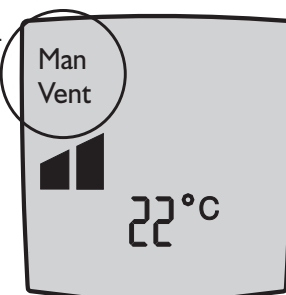
To increase or decrease the fan speed required, press either the “” or “” button.



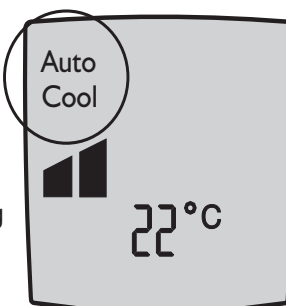

AUTO MODE

To select the AUTO mode press the “” button until AUTO is shown on the display. In AUTO mode the cooler will remember the last setting used and try to achieve this. Pressing “” or “” button will change the displayed ‘room’ temperature to a flashing ‘setpoint’ temperature.



AUTO MODE









This ‘setpoint’ temperature can be adjusted by pressing the “” or “” buttons whilst the ‘setpoint’ temperature is being displayed. After a few seconds the wall control will stop displaying the ‘setpoint’ temperature and will return to the ‘room’ temperature.

DELAYED START AND STOP

The cooler can be programmed to start at a specific time or stop at a specific time.





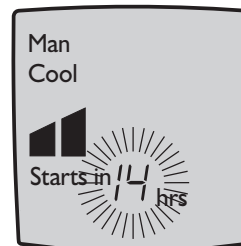

The delayed start time can only be programmed when the cooler is OFF. To program the cooler to start in a certain amount of hours use the following sequence:

PROGRAMMING IN MANUAL MODE





1. Press the “” button.
2. Press the “” button until “MAN” is displayed on the screen.
3. Press the “” or “” button until the desired fan speed is displayed by the bars in the middle of the screen.
4. Press the “” button to set either COOL or VENT.
5. Press the “” button and the ‘starts in’ time will start flashing. Use the “” and “” buttons to select the desired time.
6. Press “” again.



PROGRAMMING IN AUTO MODE

1. Press the “” button.
2. Press the “” button until flashing “AUTO” and set temperature are displayed on the screen.
3. Press the “” button and the ‘starts in’ time will start flashing. Use the “” or “” button to select the hour.
4. Press “” again.

The **delayed stop** time can only be programmed when the cooler is ON. To program the delayed time in which you want the cooler to stop use the following sequence:

1. Select the “” button and the ‘stops in’ time will start flashing. Use the “” and “” buttons to select the desired off time.
2. Press “” again.

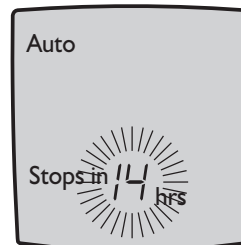

NOTE: Delayed start and stop times must be re-set every day that they are required.

OPERATING INSTRUCTIONS

SERVICE MODE

When a fault has been recognized by the wall control the word "Service" flashes on the screen. When "Service" is displayed it may be necessary for you to contact your Service Agent. However, before doing so, turn the wall control OFF.

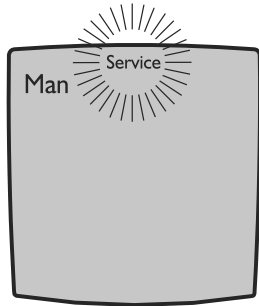

You will notice a number flashing at the bottom of the screen. This number indicates the code for the fault that has occurred.

Please write this number down, then push the "0" button to turn the cooler back on. If after a short time "Service" is again shown on the display, turn the wall control OFF and check if the flashing number is the same. If it is, check the following possible problems. Seeley International recommends that any checks be carried out by an authorised dealer or service agent.

- If '02' is displayed
Check that your local water authority has not temporarily disconnected the water in your area.
- Check that the water supply tap to the cooler is turned on.

If '04' is displayed

- Check that the drain is not blocked.

If these do not fix the problem then contact your Service Agent.

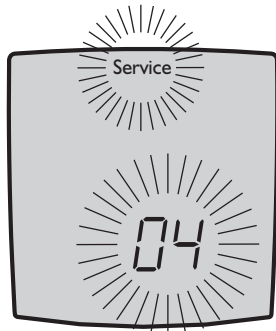

You will need to quote the flashing number that you wrote down.

ENVIROMAGIC FAULT CODES

Faults are also indicated by the left flashing LED on the cooler control board which can be viewed by removing the cover.

CODE	FAULT DESCRIPTION	RED FLASHES
01	Wall Control Communication Failure.	1 Flash
02	Failure to detect water at Low Probe.	2 Flashes
04	Failure to clear Low Probes during Drain.	4 Flashes
07	2+ motors failed, system shutdown.	7 Flashes
c	1 of 3 motors failed, system continues operating with 2 motors.	12 Flashes

A green double flash indicates the system is operating correctly. Red flashes indicate a fault.

SALINITY CONTROL

The Salinity Control Method is indicated by the right red flashing LED on the cooler control board, which can be viewed by removing the cover.

1 Flash	Salinity Control Method = Water Manager, Measured conductivity is below the conductivity set point
2 Flashes	Salinity Control Method = Water Manager, Measured conductivity is above the conductivity set point
3 Flashes	Salinity Control Method = Standard
4 Flashes	Salinity Control Method = Non-Drain Valve
5 Flashes	No water control function
ON	Lower probes are open circuit or measured conductivity is less than 9uS/cm.

DRAIN MODE

(Cooler switched OFF)

Pressing the "▲" and "▼" buttons at the same time for 2 seconds will open the drain valve and empty the water in the reservoir. The wall control will display "dr" on the screen.

Water will also be drained from the reservoir automatically after a pre-set time delay, in order to keep the cooler clean and dry until it is used again next time.

POWER OUTAGES

If the power supply fails for less than 5 seconds the cooler will retain its current settings. That is, it will stop for the time the power is off but resume operation when the power comes back on again.

If the power fails for more than 5 seconds the cooler will automatically turn itself off.

According to the chosen parameter (A7), if value 00 is set, when power comes back on, the cooler will not resume operation. The cooler will have to be re-started at the wall control.

If parameter 01 is set, the cooler will re-start again when power is restored.

TROUBLE SHOOTING

PROBLEM: Inadequate cooling	
CAUSE	REMEDY
Under-sized cooler.	Consider a second cooler.
Incorrectly sized ducting system.	Replace with larger ducts.
High Static Pressure ducting system.	Replace with less restricted system.
Clogged or dirty pads.	Replace with new pads.
Dry pads	Check water flow to pads
	Check the pumps' operation
	Check for blocked or kinked hose or obstructions in plumbing.
	Check the inlet solenoid filter for blockage.
Pumps not working correctly	Check plug, wiring and circuit breaker.
	Check water level and sensor.
	Rectify fault or replace pump or pumps.
Insufficient air discharge openings or inadequate exhaust from building, causing high humidity and discomfort.	Make sure there is adequate provision for exhausting stale air from building (open windows and doors).
Excessive ambient humidity (see also item above re inadequate exhaust).	On days during summer when ambient humidity is high the cooler will not reduce the temperature as much as on drier days. There is no remedy.
Leaking ducts or joins in the duct system.	Find leaks and seal them.
PROBLEM: Unpleasant odour	
Odour from new pads	Allow time to condition by running the cooler.
	Drain the water, then allow the tank to re-fill.
PROBLEM: Unit will not run / Wall control display fault	
No power to cooler.	Check Control Enclosure circuit breaker and reset.
	Check the main switchboard isolation circuit breaker or fuse and reset or replace.
	If there is a fault and the tripping continues investigate the cause and repair.
No power to the wall control	Check for wall control cable unplugged, faulty or damaged cable, or faulty (no display or backlighting) wall control. Replace parts as necessary.
Wall control and electronics module not communicating (Wall control displays "SERVICE" and does not clear by pushing "ON/OFF").	Reset the wall control - press and hold "  " for 10 seconds until "SERVICE" disappears from the display.
Insufficient water pressure to raise the water level to the sensor within 8 minutes.	Check that the water pressure is sufficient to fill the tank to the sensor within 8 minutes.
Drain valve remains open so water does not reach the sensor within 8 minutes.	Check that the drain valve is closed when the unit fills.
	Clean debris from the drain valve.
	Check the drain valve cable is connected and the plug is oriented correctly
PROBLEM: No water drain function	
Drain valve failure.	Replace drain valve.
Drain valve incorrectly connected to electronics module.	Check plug connection and orientation
Water sensor not operating.	Check sensor. Clean sensor.
No water from drain hose.	Check for blockages in the drain hose.
PROBLEM: Pump runs but no water circulation, Pump runs but pads lack water.	
Insufficient water in tank	Check probe cable plugged in fully, clean probes
Water hoses blocked.	Check and clean out blockage.
PROBLEM: Continuous overflow of water	
Float Valve adjustment not correct.	Adjust water level height with float.

MAINTENANCE

SEASONAL MAINTENANCE

Note: Failure to carry out regular maintenance will affect your warranty coverage!

WARNING: As your cooler is mounted on the roof, we suggest that any maintenance or checks be carried out by an authorised dealer or service agent. Climbing onto the roof can be hazardous and could result in injury to you and damage to your property.

Routine maintenance may be required more frequently in adverse environmental situations and very dusty areas.

END OF SEASON

1. Turn off the water supply to the cooler.
2. Drain the tank as shown on page 24.
3. Remove the pad frames as shown on page 13.
4. Turn off the power at the isolating switch inside the cooler.
5. Check and clean the following components
 - Water distribution spreader trays.
 - Pump.
 - Drain valve.
 - Solenoid and associated filter.
 - Fan motor.
 - Salinity probes.
 - Chlorinator Probes (if fitted)
6. Thoroughly clean the tank.
7. Refit the pad frames.

PRE-SEASON

1. Turn off power to the cooler.
2. Remove the pad frames as shown on page 13.
3. Ensure the power is off at the isolating switch inside the cooler.
4. Gently wash the pad frames to remove any dust build up during the winter. If the pads are salted-up replace them.
5. Thoroughly clean the tank.
6. Turn on the water supply to the cooler and check for water leaks.
7. Switch on the isolating switch inside the cooler.
8. Refit the pad frames.
9. Turn on the power supply to the cooler.
10. Run the cooler.

NOTE: Do not wash the pads with high pressure water spray.

WARNING: Do not run the cooler with the pad frames removed.

REPLACING THE FUSE IN THE CONTROL ENCLOSURE

A fuse is located on the main control circuit board inside the control enclosure as shown.

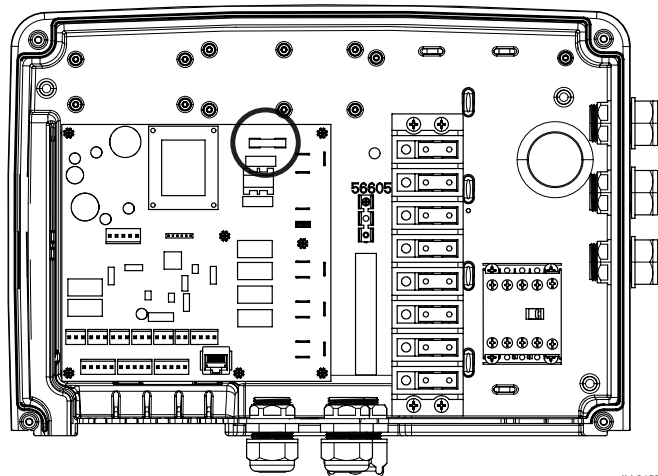

Before replacing the fuse, switch power off at service panel and lock the service disconnecting means to prevent power from being switched on accidentally. When the service disconnecting means cannot be locked, securely fasten a prominent warning device, such as a tag to the service panel.

- Remove the cover of the control enclosure by removing the 4 screws located in the corners of the enclosure.
- Remove the flexible fuse cover by sliding it off the fuse holder.
- Remove fuse carefully by grasping it and pulling it upwards and out from the fuse holder.
- **Risk of fire.** Replace fuse only with 3.15 Amp, 250 Volt fuse.
- Replace the flexible fuse cover and re-attach the cover to the control enclosure by securing the 4 screws in the corners of the enclosure.

SERVICING & INSPECTION DETAILS

SERVICE ITEM	CHECK/ADJUST					CLEAN					REPLACE				
	1	2	3	4	5	1	2	3	4	5	1	2	3	4	5
Electrical Connections and Component Operation															
Electrical wiring															
Fan motors															
Drain valve															
Water inlet solenoid															
Water probes															
Water pump															
Water Distribution System															
Chillcel pads															
Water distribution system - hoses and spreaders															
Water level															
Cabinet and Accessories															
Cabinet integrity/leaks															
Tank															
Fans															
General Operation															
Start up and run sequence															
Control operation															
General Installation															
Electrical connections															
Water connections															
Duct condition															
Roof penetrations															
Mounting & vibration isolation															
Access															

Service No	Service Date	Service Technician	Service Company
No 1
No 2
No 3
No 4
No 5

INSTALLATION CHECKLIST

Owners Name: _____ Telephone: _____

Address: _____

Dealer: _____

Installer: _____

Date Installed: _____ Model No.: _____

Serial No.: _____

INSTALLATION TASK	COMPLETE
The cooler is adequately supported, secure and level.	
The water pipes were flushed of any foreign materials before connection the cooler was made.	
The owner has been instructed on how to isolate the water to the system in case of emergency.	
The water is connected with no leaks at fittings.	
Water pipes are correctly saddled as per the applicable plumbing regulations.	
The power supply adheres to all local and national regulations and is wired back to the distribution board on its own separate circuit	
All cables have been correctly connected to the control enclosure (i.e. power supply, control cable)	
The owner has been instructed how they can electrically isolate the cooler at the meter box in case of an emergency.	
All ducts are fixed correctly and there are no air leaks.	
The customer has been shown how to operate the system.	
All the installation rubbish has been removed and, if applicable, any property damage repaired.	
Visual inspection completed no damage	
Electrical supply to cooler OK	
Cooler internal water levels checked	
Internal component check OK	
Outlet drain directed into open drain YES/NO.	
Confirm that all lid screws are tight. Screws may have loosened during shipment.	
Check supply duct is sealed. Water can be directed at joins to confirm this.	
Check all wiring connections	
Check for air leaks	
Cooler function test with control function check OK	

Signed by Installer:.....Commissioning Engineer.....

Date:Date:.....

HOW TO REGISTER YOUR PRODUCT WARRANTY (Australia only)

HOW TO REGISTER YOUR PRODUCT WARRANTY (Australia only)

Please register your warranty online by visiting www.seeleyinternational.com and following these steps:

Step 1 Select “GET SUPPORT” and “REGISTER A WARRANTY”

Step 2 Select the brand of the product you purchased

Step 3 Enter the required information and “Submit”

(Alternatively, if you have a smart phone or tablet, using an app you can scan the QR code on the back of the manual provided with the cooler, which will take you directly to the webpage for product warranty registration.)

Important Note: You need to have the following information to complete your registration:

- your unit model and size
- serial number
- date your system was installed
- name of the dealer you purchased it from

Please complete this section. You will also need to retain your purchase receipt, and proof of any warranty period extension.

Brand: _____

Model: _____

Serial No: _____

Customer Name: _____

Installation Address: _____

Installation Type: Residential / Non Residential / Commercial

Date of installation: _____

Installer / Dealer: _____

WARRANTY TERMS AND INFORMATION (Australia only)

In this warranty:

We or us means Seeley International Pty Ltd (Seeley) ABN 23 054 687 035, and our contact details are set out at the end of this warranty;

You means you, the original end-user purchaser of the Goods;

Supplier means the authorised distributor or retailer of the Goods that sold you the Goods in Australia;

Goods means the product, unit, appliance or equipment which was accompanied by this warranty and purchased in Australia; and

Relevant Warranty Period means the various warranty periods as described in clause 1, clause 2 and clause 3 below, as appropriate.

Our Goods come with guarantees that cannot be excluded under the Australian Consumer Law. You are entitled to a replacement or refund for a major failure and for compensation for any other reasonably foreseeable loss or damage. You are also entitled to have the Goods repaired or replaced if the Goods fail to be of acceptable quality and the failure does not amount to a major failure.

In addition to any rights and remedies that You may have under the Australian Consumer Law or any other law, subject to the terms of this warranty, We provide the following warranty:

1. If during the first two (2) years from the date of purchase when the Goods are used for commercial or industrial purposes a fan motor proves defective by reason of improper workmanship or material, We will repair or replace at our option that fan motor without charge for either parts or labour during normal working hours.
2. If during the first (1) year from the date of purchase when the Goods are used for commercial or industrial purposes any other component of the Goods proves defective by reason of improper workmanship or material, We will repair or replace at our option the relevant part without charge.
3. The warranties granted under clause 1 and clause 2 do not cover:
 - a. fair or normal wear and tear;
 - b. damage, loss or claims caused by, resulting from, or arising out of any utilities that service or are connected to the Goods. This includes but it is not limited to electrical surges, and inadequacies, failure, or other problems in or with any electricity, power, or water supply to the Goods;
 - c. after the first year: the replacement, supply, or servicing of consumable items (including without limitation washers, seals, and drive belts); and
 - d. installation (including without limitation ductwork, fittings, and other related installation components) which is excluded.
4. Seeley also warrants the structural integrity of all components made from our exclusive Permatuf polymers for ten (10) years and your evaporative air cooler cabinet (base, top, corner supports, side panels, fan and fan housing) against damage caused to it by all forms of corrosion for twenty five (25) years.

WARRANTY TERMS AND INFORMATION (Australia only) cont.

5. During the period to which any expressed warranty applies, all defective part(s) shall be replaced or repaired (at the discretion of Seeley) without charge for either parts or labour, during normal working hours. Further, we may deem in our absolute discretion to replace the Goods, and if so, we may substitute any similar good even if it is not on our current price/equipment list. Further, Goods presented for repair may be replaced by refurbished goods of the same type rather than being repaired. Refurbished parts may be used to repair the Goods.
6. We are under no obligation to repair or replace the parts under clause 1, clause 2 or clause 3 above (nor do we have any obligation to repair or replace the Goods) if (i) the Goods have not been installed and commissioned in accordance with the instructions in the Owner's Manual (ii) the Goods have not been installed and commissioned properly or competently, (iii) the Goods have not been operated, serviced and maintained in accordance with the instructions provided in the Owner's Manual, or (iv) if any such service or maintenance has not been properly or competently performed. It is a condition of warranty cover that each item in the Maintenance Schedule in the Owner's Manual (if it was published with such a Schedule) is performed with the frequency indicated, by a qualified, licensed technician, and that the Maintenance Schedule is properly filled out (ie names, signature, date, and action taken) when the item is completed. Any failure to carry out the required maintenance and servicing requirements, and any failure to properly fill out a Maintenance Schedule in the Owner's Manual, will void your warranty. The addition of any third party device, (except where it is required by the installation instructions and complies with those instructions), or the removal or alteration of any Seeley component, or damage due to misuse of the unit, or faulty installation or commissioning, will void this warranty.
7. As far as the law permits, We will not be liable for any consequential loss suffered through, or resulting from, the non-operation, or ineffective operation of the air cooler. The warranties granted under clause 1, clause 2 and clause 3 do not cover damage to the air cooler or other loss resulting from acts of God.
8. No other person, corporation or other entity is authorised to offer, or give on our behalf, any other warranty. The benefits conferred are in favour of You and any person deriving title to the air cooler whilst in its original place of installation. Nothing in this warranty shall be construed as affecting any rights You may have under all the relevant laws, or Commonwealth or State Legislation which give You rights which cannot be modified or excluded by agreement.
9. In order to claim under the warranties granted under clause 1, clause 2 or clause 3 You must:
 - a. either:
 - contact us within the Relevant Warranty Period on: 1300 650 644; or
 - log a warranty claim on our website (website address below) within the Relevant Warranty Period; and
 - b. make available for inspection by the service agent who will come to the location of the Goods or send to us at the address below within the Relevant Warranty Period: (i) the legible and unmodified original proof of purchase, which clearly indicates the name and address of the original retailer, the date and place of purchase, the product name or other product serial number, (ii) all of your records of all service and maintenance carried out to the Goods, plus the Maintenance Schedule in the Owner's Manual (if it was published with such a Schedule) (iii) a copy of the completed Warranty Information page in this warranty, and (iv) if an extended warranty period was provided by us for the Goods, then the relevant document provided by us confirming that extended warranty period. If you choose to send the documents described in (i) to (iv) to us, then they must be accompanied by a covering letter which states your name and address and daytime telephone number, the address at which the Goods are installed, and the model and serial number of the Goods.
10. The warranties granted in clause 1, clause 2 and clause 3 cover the costs of parts and labour but you will be responsible for:
 - a. the cost of travel incurred for a Seeley International service agent to get to and from the location of the Goods if the location of the Goods is either: (i) outside the metropolitan areas of the capital cities; or (ii) more than 35 kilometres from an authorised Seeley International branch or service representative; and
 - b. any costs for additional labour or equipment associated with gaining acceptable and safe service access to the Goods installed in restricted, high or unsafe locations, and or the removal and replacement of any barrier, walls, roofs, floors, fences etc; and
 - c. any costs incurred by the Seeley International service agent in gaining access to the Goods which is necessary to comply with any safety or workplace safety requirements and/or any other relevant regulations. For the avoidance of doubt, the reference to any costs incurred also includes the cost of any necessary site inductions.
11. Seeley International is not responsible in any way for any failure and/or inadequate performance of the Goods which arises from or is connected to the use in the Goods of non-genuine spare parts. Seeley International strongly recommends that only spare parts supplied or approved by it are used in the Goods.
12. We are not responsible for the installation of the Goods and expressly disclaim all liability resulting from incorrect installations or installations that do not conform to local electrical codes, local plumbing codes, Occupational Health and Safety requirements, and by laws which are legislated or in effect at the time of installation.
13. This warranty is only valid and enforceable in Australia.

Note: We and our service agents reserve the right to refuse service unless safety and accessibility to the unit can be guaranteed. If a service call reveals no warranty fault found with the Goods, a charge will be made for the call.

Our liability under this warranty is limited to the extent permitted by law. That is, to the extent that it is fair and reasonable, if the Goods are not of a kind ordinarily acquired for personal, domestic or household use or consumption, your remedies associated with any failure or defect of the product will be limited to:

- (a) the replacement of the Goods or the supply of equivalent goods;
- (b) the repair of the Goods;
- (c) the payment of the cost of replacing the Goods or of acquiring equivalent goods; or
- (d) the payment of the cost of having the Goods repaired

and subject to the terms and conditions included in this warranty.

WARRANTY TERMS AND INFORMATION (Australia only) cont.

Service Department

Seeley International Pty Ltd

112 O'Sullivan Beach Road

Lonsdale, South Australia 5160

Customer service centre 1300 650 644

Website: www.seeleyinternational.com

FOR SERVICE

Service call Booking

To book a Service on your Seeley International product Online visit www.seeleyinternational.com

Step 1 Select "GET SUPPORT" and "REQUEST A SERVICE BOOKING"

Step 2 Click on "SERVICE REQUEST"

Step 3 Select the brand of the product you require a service on and follow the prompts, or Phone 1300 650 644 to be directed to your closest authorised Service Agent

PRIVACY NOTICE

Seeley International Pty Ltd ABN 23 054 687 035 will use the personal information you provide us with to provide warranty support for the product you have purchased and to inform you about other products and services. If you choose not to supply us with the information requested, we may be unable to provide you with warranty support. We may also disclose your information to third parties, such as related entities; retailers, distributors, service agents and contractors who are affiliated with us; or marketing or market research companies. If you would prefer not to receive direct marketing communications from us, please follow the instructions to "unsubscribe" which will be included in the direct marketing communications we send you, or contact our Privacy Officer using the details set out below. While we do not currently transfer personal information to overseas recipients or store personal information overseas, if we transfer your information to third parties who do so, we will take reasonable steps to ensure that the overseas recipients do not breach the *Australian Privacy Principles*. By registering your warranty, you consent to having your personal information used in this way. Please read our Privacy Policy on our website www.seeleyinternational.com for further explanation of how we collect, use, hold and disclose personal information, and how you may access and seek correction of your information. It also sets out how you may complain about a breach of the Australian Privacy Principles, and how we will deal with your complaint. You may contact us at: Privacy Officer, Seeley International Pty Ltd, 112 O'Sullivan Beach Road, Lonsdale, South Australia 5160.

NOTES

Installation, Operation and Maintenance Manual

Now provided on the internet
available in English and Spanish

Refer www.seeleyeurope.com



Service - All regions: Please contact your local Breezair distributor.

seeleyinternational.com

MANUFACTURED BY: SEELEY INTERNATIONAL PTY LTD
112 O'SULLIVAN BEACH RD, LONSDALE SA, 5160. AUSTRALIA

IMPORTED BY: SEELEY INTERNATIONAL (EUROPE) LIMITED
UNIT 11, BYRON BUSINESS CENTRE, HUCKNALL, NOTTINGHAM, NOTTINGHAMSHIRE, NG15 7TN, UNITED KINGDOM

SEELEY INTERNATIONAL (AMERICAS)
1002 S 56TH AVENUE, SUITE# 101, PHOENIX, AZ 85043, USA

SEELEY INTERNATIONAL AFRICA (PTY) LTD
6 WITTON ROAD, FOUNDERSVIEW SOUTH, MODDERFONTEIN 1609, GAUTENG, SOUTH AFRICA

It is the policy of Seeley International to introduce continual product improvement.
Accordingly, specifications are subject to change without notice.
Please consult with your dealer to confirm the specifications of the model selected.