

This Owner's Manual is provided and hosted by [Appliance Factory Parts](#).



DIAL 36000Z-03-O Owner's Manual

[Shop genuine replacement parts for DIAL 36000Z-03-O](#)



[Find Your DIAL Air Conditioner Parts - Select From 23 Models](#)

----- Manual continues below -----



USE AND INSTALLATION INSTRUCTIONS

Thank you very much for purchasing this Air Conditioner. Please read these **Use and Installation Instructions** carefully before installing and using this appliance. And keep this manual for future reference.

Attention: If you are experiencing difficulty with your mini-split air conditioner, do not return it to the place of purchase. Contact Dial Manufacturing for help or disposition.

ÖaãT ađ ~ æc lã * ÆQ&E
G ÁU[~ cã F• cã ^) ^ ÆU@ ^) a ÆZÁ í € H
FË €€H €€OS/ãã • d { ^!•^!çã^O áãã ~ ÆU {

Contents

Safety instructions.....1

Refrigerant flow diagram.....3

Installation instruction4

Installation diagram4

Transportation and handing before installation5

Select the installation locations.....5

Install drainage elbow and drain hose5

Outdoor installation6

Refrigerant piping.....6

Wiring9

Trial run13

NOTE:

- This heat pump air conditioner has been designed for the following temperatures. Operate the heat pump air-conditioner within this range.

Mode	Outdoor Working Temperature	
	Maximum	Minimum
Cooling Operation	115°F(46°C)	14°F(-10°C)
Heating Operation	75°F(24°C)	-13°F(-25°C)



- Storage condition: Temperature -13~140°F (-25~60°C)
Humidity 30%~80%

Safety precautions

1. This air conditioner uses new refrigerant HFC (R410A).
2. Since the max. working pressure is 550 PSIG (3.8MPa), proper piping, installation and service tools are required.
3. Power supply for this air conditioner is: 208-230V ~, 60Hz.

Please read these SAFETY PRECAUTIONS carefully to ensure correct installation.

- Be sure to use a dedicated power circuit, and do not put other loads on the power supply.
- Be sure to read these SAFETY PRECAUTIONS carefully before installation.
- Be sure to comply with these SAFETY PRECAUTIONS during installation.
- Definitions for identifying hazard levels are provide below with their respective safety symbols.

-  **WARNING:** Hazards or unsafe practices which COULD result in severe personal injury or death.
-  **CAUTION:** Hazards or unsafe practices which COULD result in minor personal injury or product or property damage.

- Please carefully file indoor and outdoor unit manual away for future reference.



- We recommend that this air-conditioner be installed properly by qualified installation technicians in accordance with the installation instructions provided with the unit.
Incomplete installation may result in damage by fire, electric shock, or water leakage.
- Wiring must be done by a qualified electrician.
- Install the air conditioner on a solid base that can support the unit weight.
An inadequate base or incomplete installation may cause injury in the event the unit falls off the base.
- Use the specified type of wire for electrical connections safely between the indoor and outdoor units. And firmly connected to the connection part of wire terminals, so that the wire stress will not be applied to these parts. Incomplete connection may result in fire.
- For wiring, use a wire long enough to cover the entire distance with no connection. And don't connect multiple devices to the same AC power supply.
- After all installation is complete, check to make sure that no refrigerant is leaking. Refrigerant gas leakage will generate harmful substances when exposed to heat of flame.
- Perform the installation securely referring to the installation manual. Incomplete installation could cause a personal injury due to fire, electric shock, the unit falling or leakage of water.
- In accordance with the installation instructions for electrical work, please be sure to use a dedicated line.
- If the power supply circuit capacity or electrical work is not in place, a fire or electric shock may occur.
- Attach the electrical cover to the indoor unit and the service panel to the outdoor unit securely.
- If the electrical covers on the indoor unit or the service panel of the outdoor unit are not attached securely, fire or an electric shock due to dust water may occur.
- Please be sure to cut off the main power supply before installation of indoor electronic PCB or wiring. Otherwise, electric shock may occur.
- Installation of the device should be in accordance with the state provisions for installation wiring.
- The outdoor machine installation location should be protected and avoid contact with people or other small animals, please keep the outdoor unit and the surrounding environment clean and tidy.
- When installing or relocating the unit, make sure that no substance other than the specified refrigerant (R410A) enters the refrigerant circuit. Any presence of foreign substance such as air can cause abnormal pressure rise or an explosion.

Safety precautions



- Perform grounding
Do not connect the earth wire to a gas pipe, water pipe, lightning rod or telephone earth wire. Defective grounding could cause an electric shock.
- Do not install the unit in a place where a flammable gas leaks.
If gas leaks and accumulates in the area surrounding the unit, it could cause an explosion.
- Fasten a flare nut with a torque wrench as specified in this manual.
When fastened too tight, a flare nut may break and cause a refrigerant leak.
- Install an earth leakage breaker depending on the installation place (where it is humid).
If an earth leakage breaker is not installed, it could cause an electric shock.
- Perform the drainage/piping work securely according to the installation manual. If there is a defect in the drainage/piping work, water could drop from the unit and household goods could be wet and damaged.

Safety instructions

- Do not let air enter the refrigeration system or discharge refrigerant when moving the air conditioner.
- The installation instructions for appliances that are intended to be permanently connected to fixed wiring, and have a leakage current that may exceed 10 mA, shall state that the installation of a residual current device (RCD) having a rated residual operating current not exceeding 30 mA is advisable.
- This appliance is not intended for use by persons (including children) with reduced physical, sensory or mental capabilities, or lack of experience and knowledge, unless they have been given supervision or instruction concerning use of the appliance by a person responsible for their safety.
- Children should be supervised to ensure that they do not play with the appliance.
- If the appliance is fixed wiring, the appliance must be fitted with means for disconnection from the supply mains having a contact separation in all poles that provide full disconnection under over voltage category III conditions, and these means must be incorporated in the fixed wiring in accordance with the wiring rules.
- If the supply cord is damaged, it must be replaced by the manufacturer, its service agent or similarly qualified persons in order to avoid a hazard.
- The appliance shall be installed in accordance with national wiring regulations.
- Servicing shall only be performed as recommended by the equipment manufacturer.
- The method of connection of the appliance to the electrical supply and interconnection of separate components is detailed in below part. The wiring diagram with a clear indication of the connections and wiring to external control devices and supply cord is detailed in below part. The cord of the H07RN-F type or the electrically equivalent type must be used for power connection and interconnection between outdoor unit and indoor unit. The size of the cord is detailed in below part.
- In order to avoid a hazard due to inadvertent resetting of the thermal cut-out, this appliance must not be supplied through an external switching device, such as a timer, or connected to a circuit that is regularly switched on and off by the utility.
- It is necessary to allow disconnection of the appliance from the supply after installation. The disconnection may be achieved by incorporating a switch in the fixed wiring in accordance with the wiring rules. During service and when replacing parts, be sure to disconnect the appliance from its power source. If the disconnection is not foreseen, a disconnection with a locking system in the isolated position shall be provided.
- The information of dimensions of the space necessary for correct installation of the appliance including the minimum permissible distances to adjacent structures is detailed in below part.
- Instructions on addition charging of refrigerants are detailed in below part.

Refrigerant flow diagram

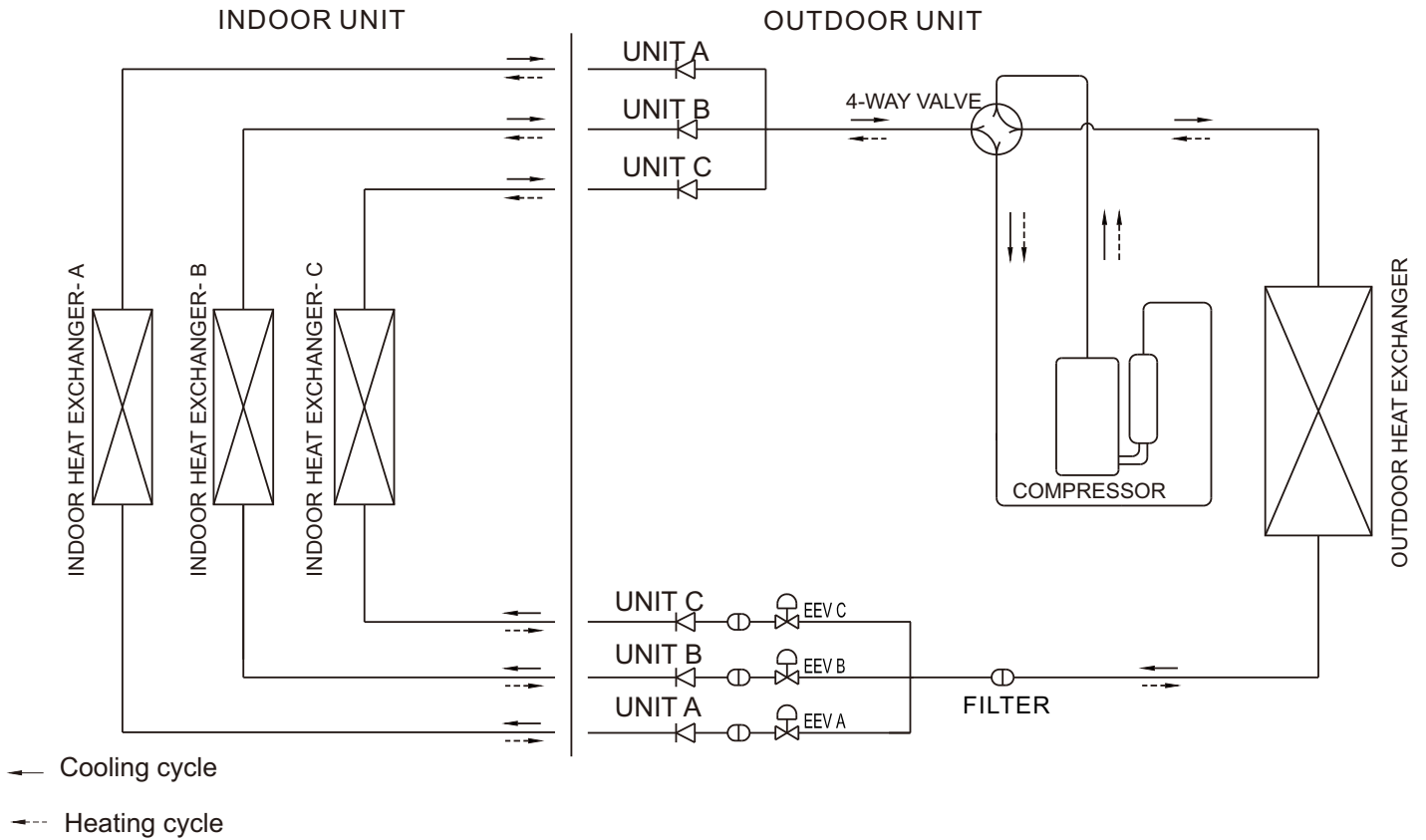

24K

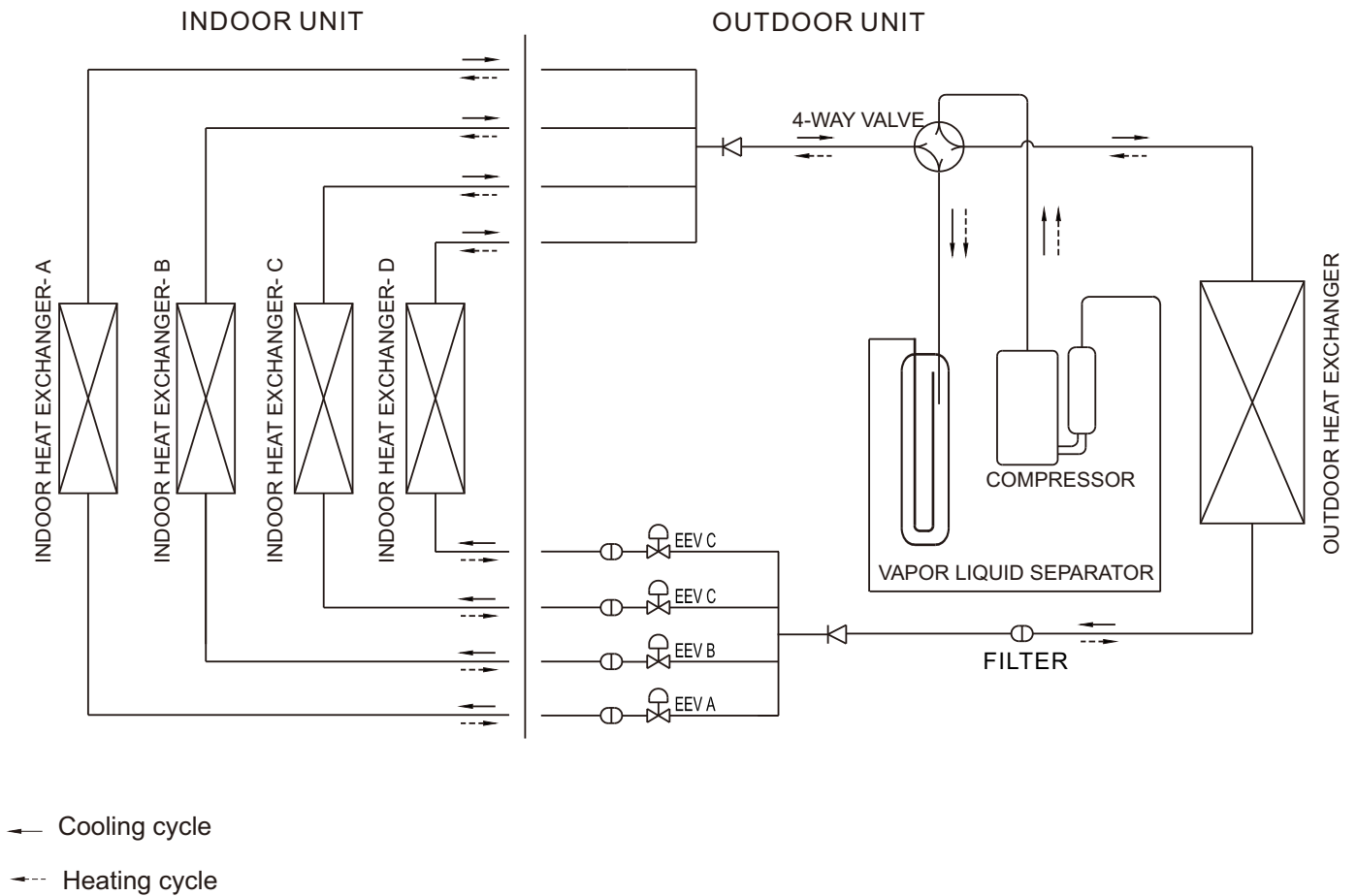

36K

Installation instructions

Installation diagram

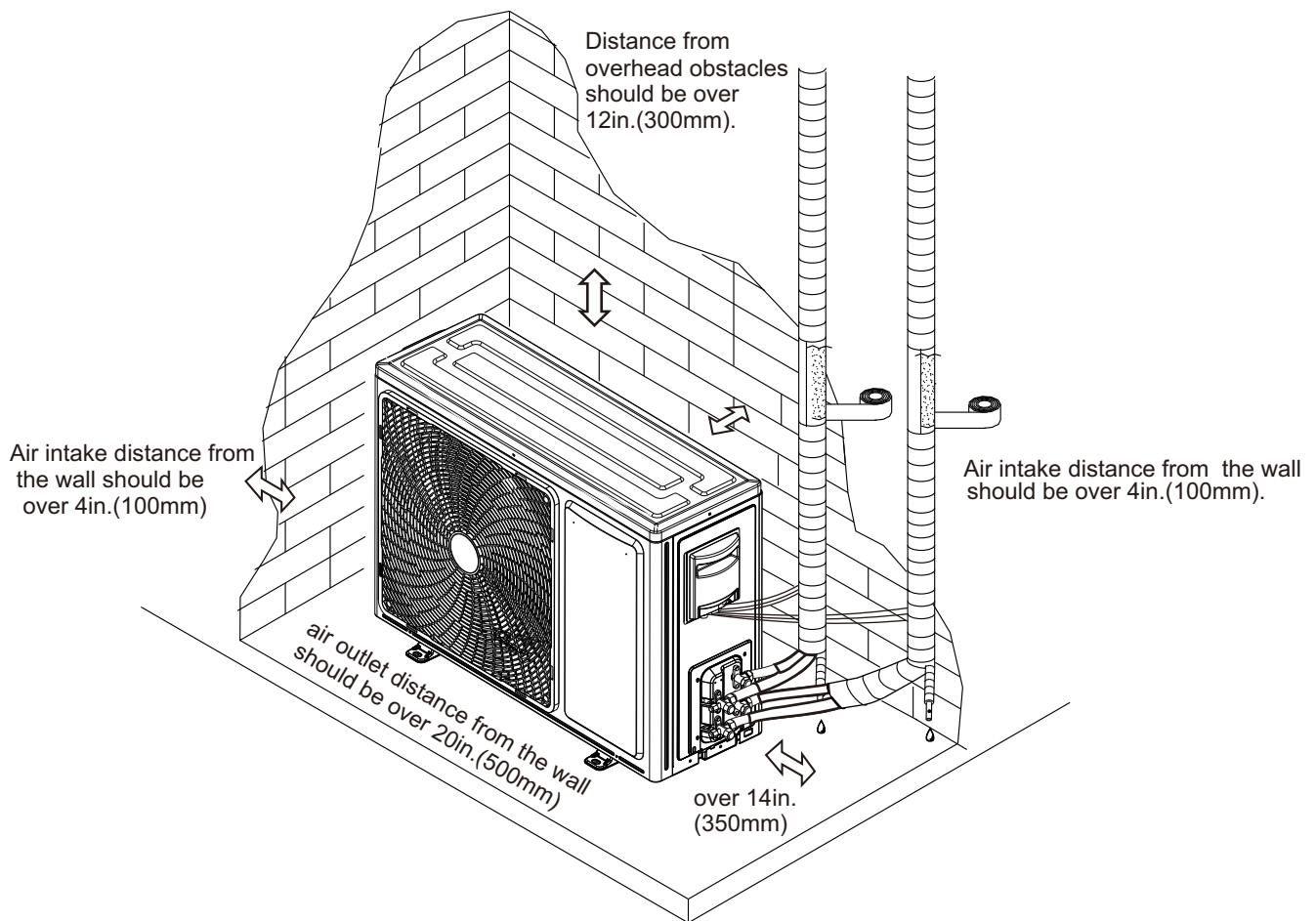

outdoor unit

- ☑ **Figures in this manual are only a simple presentation of the unit, it may not match the external appearance of the unit you purchased.**
- **Installation must be performed in accordance with the national wiring standards by authorized personnel only.**

Installation instructions

Transportation and Handling before Installation

Transport the product as close to the installation location as practical before unpacking.

• Hanging Method

When hanging the unit, ensure a balance of the unit, check safety and lift up smoothly.

- (1) Do not remove any packing materials.
- (2) Hang the unit under packing condition with two ropes, as shown in Fig. blow.

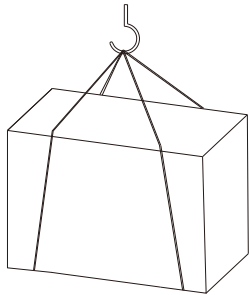

• Hanging

If have no package to move , Please protect with cloth or paper.

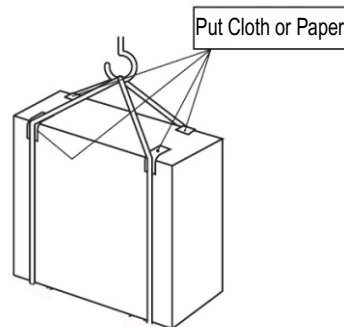

Select the installation locations

Choose an installation site where the following conditions are met:

- Where it is not exposed to strong wind.
- Where airflow is good and clean.
- Where it is not exposed to rain and direct sunshine.
- Where neighbors are not annoyed by operation sound or hot air.
- Where rigid wall or support is available to prevent the increase of operation sound or vibration.
- Where there is no risk of combustible gas leakage.
- Where it is at least 9-5/6 ft. (3m) away from the antenna of TV set or radio. An amplifier may be required for the affected device.
- Install the unit horizontally.
- Please install it in an area not affected by snowfall or blowing snow. In areas with heavy snow, please install a canopy, a pedestal and/or some baffle boards.

⚠ CAUTION:

Avoid the following places for installation:

- Where oil, gasoline, or other flammable substances are present.
- Where it may be exposed to salt water.
- Where sulfide gas is generated such as a hot spring.
- Where there is high-frequency or wireless equipment.

Note:

When operating the air conditioner in low outside temperature, be sure to follow the instruction described below.

- Never install the outdoor unit in a place where its air inlet/outlet side may be exposed directly to wind.
- To prevent exposure to wind, install the outdoor unit with its air inlet side facing the wall.
- To prevent exposure to wind, it is recommended to install a baffle board on the air outlet side of the outdoor unit.

Install drainage elbow and drain hose

Install Drainage Elbow and Drain Hose

• Condensate water may drains from the outdoor unit when the unit operates in heating mode. In order to avoid disturbing neighbors and to protect the environment, it is necessary to install a drainage elbow and a drain hose to drain the condensate water.

• Please do the drainage work before the indoor unit and outdoor unit are connected. Otherwise, it will be difficult to install drainage elbow after the machine becomes immovable.)

• Connect the drain hose [field-supplied, inside diameter: 13/22in.(15mm)] as shown in the figure for drainage.

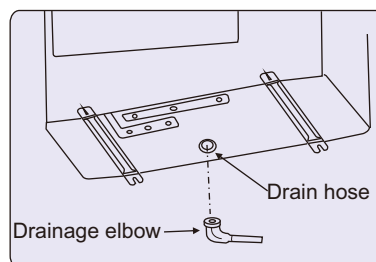

Note:

Do not use the drain elbow in the cold region. Drain may freeze to stop the fan runs.

Installation instructions

Outdoor Installation

⚠ NOTE:

- Be sure to fix the unit's legs with bolts during installation.
- Be sure to install the unit firmly to ensure that it will not fall during an earthquake or strong winds.
- The anchor bolts, nuts and washers for the installation are user prepared.

unit: inch(mm)

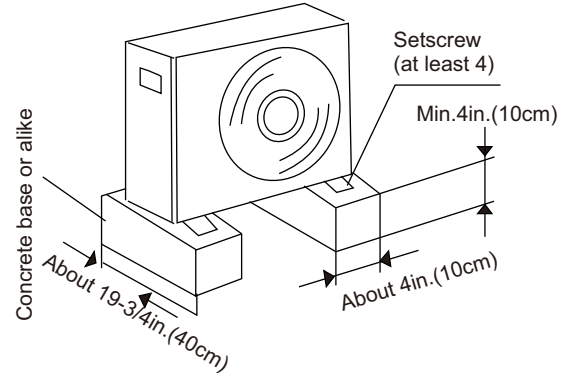
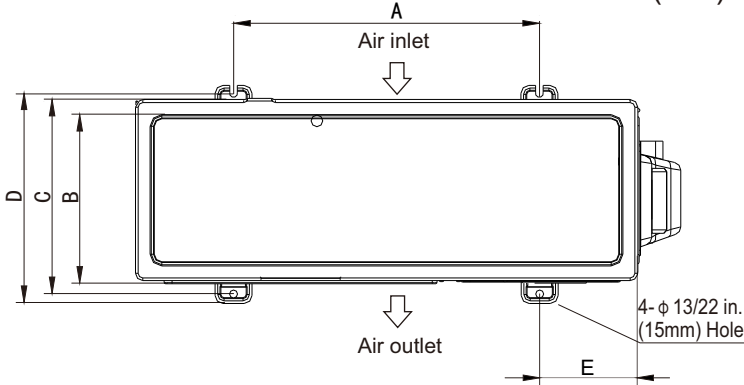

Cooling Capacity (Btu/h)	A	B	C	D	E
24K/36K	22-5/6 (580)	13-2/5 (340)	15 (381)	16-2/7 (413)	7-2/7 (185)

Refrigerant Piping

1. Piping Requirement

Model	Outer Diameter of Pipe (in./mm)	
	Gas	Liquid
24K/36K	3/8 (9.52)	1/4 (6.35)

Refrigerant piping should be as short as possible.

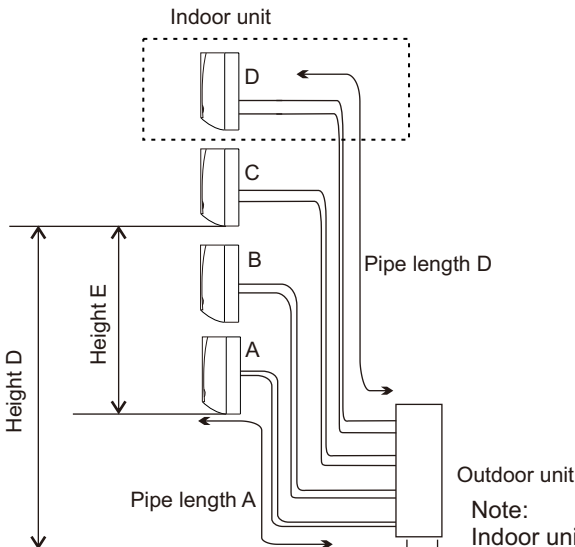

Model		24K	36K
Max. Length Between Indoor Unit and Outdoor Unit	ft./m	A ≤ 65-5/8 (20) B ≤ 65-5/8 (20) C ≤ 65-5/8 (20)	A ≤ 65-5/8 (20) B ≤ 65-5/8 (20) C ≤ 65-5/8 (20) D ≤ 65-5/8 (20)
	ft./m	A+B+C ≤ 196-6/7 (60)	A+B+C+D ≤ 246-1/16 (75)
	ft./m	D ≤ 49-1/5 (15)	D ≤ 49-1/5 (15)
Max. Height Between Indoor Units	ft./m	E ≤ 24-3/5 (7.5)	E ≤ 24-3/5 (7.5)

Note:
Indoor unit D in the circle is only valid for 36K model.

Refrigerant Additional Charge

The unit has been filled with refrigerant, but if L (total pipe length) exceeds standard length, additional refrigerant (R410A) change is required.

For 24K: Additional refrigerant charge = $[L - 74 - 4/5 (22.8m)] \times 0.807 \text{ oz/5ft (15g/m)}$

For 36K: Additional refrigerant charge = $[L - 98 - 3/7 (30m)] \times 0.807 \text{ oz/5ft (15g/m)}$

2. Piping Material

- (1) Select clean copper pipes. Make sure there is no dust and moisture inside of the pipes. Blow the inside of the pipes with nitrogen or dry air, to remove any dust or foreign materials before connecting pipes.

Installation instructions

(3) Piping thickness and material as specified below.

Diameter [inch(mm)]	Thickness [inch(mm)]
1/4(Φ6.35)	1/32(0.8)
3/8(Φ9.52)	1/32(0.8)
1/2(Φ12.7)	1/32(0.8)
5/8(Φ15.88)	2/51(1.0)

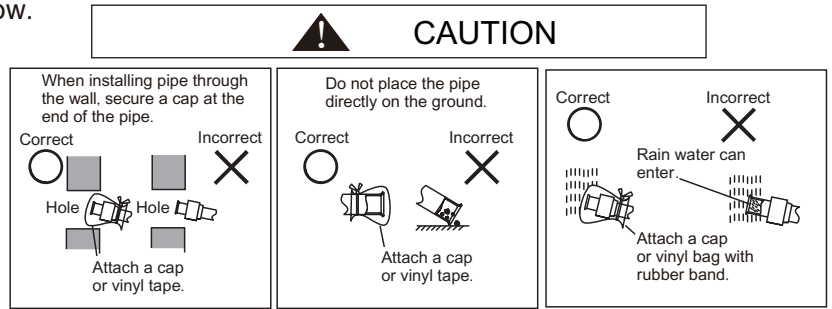

3. Processing of Refrigerant Piping

(1) Pipe cutting

- Cut the copper pipe correctly with pipe cutter.

(2) Burr removal

- Completely remove all burrs from the cut cross section of the pipe.
- Put the end of the copper pipe downward to prevent burrs from dropping in the pipe.

(3) Putting nut on

- Remove flare nuts attached to indoor and outdoor units, then put them on pipe having completed burr removal.
(Not possible to put them on after flaring work).
- Flare nut for pipe depending on the diameter of pipe.

(4) Flaring work

- Perform flaring work using flaring tool as shown below.

(5) Check

- Compare the flared work with the figure to the right.
- If flare is found to be defective, cut off the flared section and perform flaring work again.

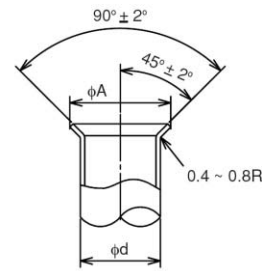

Diameter Φd	A ⁺⁰ _{-0.4} inch(mm)
1/4(6.35)	1/3(9.1)
3/8(9.52)	13/25(13.2)
1/2(12.7)	17/26(16.6)
5/8(15.88)	7/9(19.7)

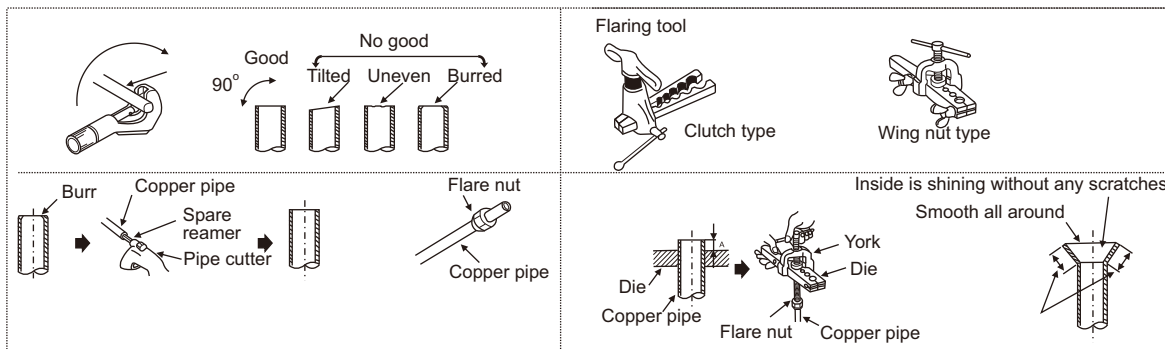

4. Piping Connection

(1) Confirm that the valve is closed.

(2) Connect the indoor unit and the outdoor unit with field-supplied refrigerant piping. Suspend the refrigerant piping at certain points and prevent the refrigerant piping from touching the weak part of the building such as wall, ceiling, etc.

(If touched, abnormal sound may occur due to the vibration of the piping. Pay special attention in case of short piping length.)

(3) Tighten the flare nut using two spanners as shown in figure.

(4) Apply the refrigerant oil (field-supply) thinly at the seat surface of the flare nut and pipe before connecting and tightening.

And when tightening the flare nut, use two spanners.

(5) Outdoor refrigerant piping should connect with stop valve.



Double Spanner work

Pipe Size [inch(mm)]	Torque
1/4(Φ6.35)	14.75ft-lb (20N·m)
3/8(Φ9.52)	29.5ft-lb (40N·m)
1/2(Φ12.7)	44.25ft-lb (60N·m)
5/8(Φ15.88)	59ft-lb (80N·m)

Tightening Torque for Flare Nut

Installation instructions

- (6) After finishing connecting the refrigerant pipes, insulate it with insulation material like the figure on the right.
- For outdoor unit, insulate entire length of piping including valves.
 - Cover piping joints with pipe cover.
 - Using piping tape, apply taping starting from the entry of outdoor unit. Fix the end of piping tape with adhesive tape.
 - When piping has to pass through ceiling, closet or area where temperature and humidity are high, wrap additional commercial or industrial grade insulation to prevent condensation.

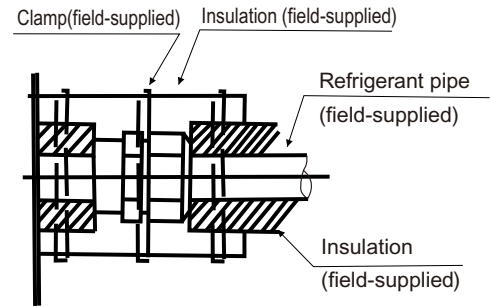

Piping insulation procedure



CAUTION

If the diameter of the connection pipe does not match the port size of outdoor unit, select the proper coupling according to the following table.

Name	Qty	Purpose
	1	Change pipe diameter from 1/4(6.35) to 3/8(9.52)
	1	Change pipe diameter from 3/8(9.52) to 5/8(15.88)
	1	Change pipe diameter from 3/8(9.52) to 1/2(12.7) mm

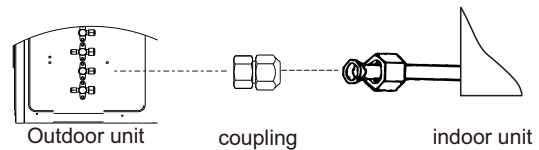

Connect pipes using different-diameter joint

5. Air Tight Test

● Air Tight Check - USE Nitrogen.

Connect the gauge manifold using charging hoses with a nitrogen cylinder to check the joints of the liquid line and the gas line stop valves. Perform the air-tight test.

Don't open the gas line stop valves.

Apply nitrogen gas pressure of 550psi (3.8MPa).

Check for any gas leakage at the flare nut connections, or brazed parts with gas leak detector or foaming agent.

Verify that the gas pressure doesn't decrease.

After the air tight test is complete, release nitrogen gas.

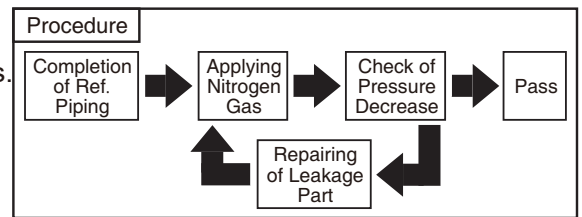

Air tight procedure

6. Vacuum Pumping and Charging Refrigerant

● Vacuum Pumping

- (1) Remove the service port cap of the stop valve on the gas pipe side of the outdoor unit.
- (2) Connect the manifold gauge and vacuum pump to the service port of the stop valve on the gas pipe side of the outdoor unit.
- (3) Run the vacuum pump (more than 15 minutes.)
- (4) Check the vacuum with the gauge manifold valve, then close the gauge manifold valve and stop the vacuum pump.
- (5) Leave as is for one or two minutes. Make sure the manifold gauge remains in the same position. Confirm that the pressure gauge shows -14.7 psi(-0.101MPa or -760mmHg).
- (6) Remove the manifold gauge quickly from the service port of the stop valve.
- (7) After refrigerant pipes are connected and evacuated, fully open all stop valves on both sides of gas pipe and liquid pipe.
- (8) Open adjusted valve to add refrigerant (refrigerant must be liquid).
- (9) Replace the service port cap and tighten securely.
- (10) Leak test foam with halogen leak detector to check the flare nut and brazed joints for leaks. Use foam that does not generate ammonia (NH₃) in the reaction.

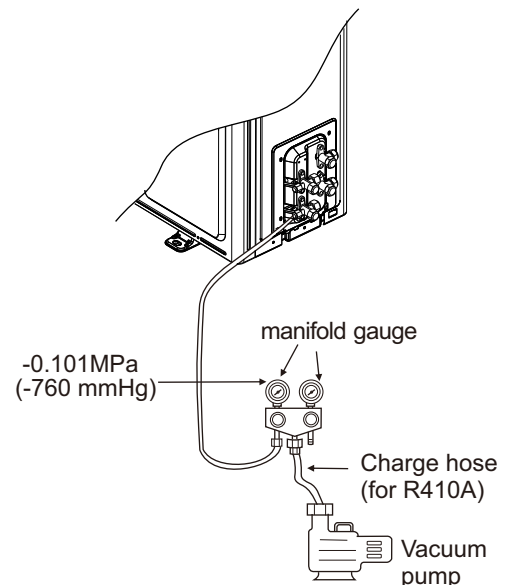

Installation instructions



CAUTION

- Each pipeline needs to be evacuated individually.
- An excess or a shortage of refrigerant is the main potential cause of trouble to the unit. Charge the correct refrigerant quantity according to the description in the manual.
- Check for refrigerant leakage thoroughly. If a large refrigerant leakage occurs, it will cause difficulty with breathing or harmful gases would occur if a fire was being used in the room.

● Additional refrigerant charge

The unit has been filled with refrigerant.

Please calculate additional charge according "Piping Requirement".

After vacuum pump procedure has been finished, first exhaust air from charge hose, then open valves, charge refrigerant as "liquid" type through Liquid stop valve.

At the end, please close valves and record the refrigerant charging quantity.

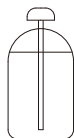

Filling a cylinder with an attached siphon

Stand the cylinder upright when filling.

(Stand the cylinder upright when filling.
There is a siphon pipe inside, so the cylinder
need not to be upside-down to fill with liquid.)



Filling other cylinders

Turn the cylinder upside-down when filling.

Wiring



WARNING

- Turn OFF the main power switch to the indoor unit and the outdoor unit and wait for more than 3 minutes before electrical wiring work or a periodical check is performed.
- Check to ensure that the indoor fan and the outdoor fan have stopped before electrical wiring work or a periodical check is performed.
- Protect the wires, electrical parts, etc. from small animals. If not protected, animals may gnaw at unprotected parts and at the worst, a fire will occur.
- Avoid allowing the wirings to touch the refrigerant pipes, plate edges and electrical parts inside the unit. Otherwise, the wires will be damaged and at the worst, a fire will occur.
- Install an ELB (Electric Leakage Break) in the power source.
If ELB is not used, it will cause electric shock or fire at the worst.
- This unit uses an inverter, which means that it must be used with earth leak detector capable of handling harmonics in order to prevent malfunctioning of the earth leak detector itself.
- Do not use intermediate connection wires, stranded wires (see <Attentions when Connect the power supply wiring>), extension cables or control line connections, because the use of these wires may cause electric shock or fire.
- The tightening torque of each screw shall be as follows.
M4: 0.74 to 0.96 ft-lb (1.0 to 1.3 N-m)
M5: 1.5 to 1.8 ft-lb (2.0 to 2.5 N-m)
M6: 3 to 3.7 ft-lb (4.0 to 5.0 N-m)
M8: 6.6 to 8.1 ft-lb (9.0 to 11.0 N-m)
M10: 13.3 to 17 ft-lb (18.0 to 23.0 N-m)
Keep the above tightening torque when wiring work.



CAUTION

- Use tape material along the wire wrapped, sealed wiring holes to prevent the unit from condensed water and insects.
- Tightly secure the power source wiring using the cord clamp inside the unit.

Note: Fix the rubber bushes with adhesive when conduit tubes to the outdoor unit are not used.

Installation instructions

General Check

- (1) Make sure that the field-selected electrical components (main power switches, circuit breakers, wires, conduit connectors and wire terminals) have been properly selected according to the electrical data.
Make sure that the components comply with National Electrical Code (NEC).
- (2) Check to ensure that the voltage of power supply is within +10% of nominal voltage and earth phase is contained in the power supply wires. If not, electrical parts will be damaged.
- (3) Check to ensure that the capacity of power supply is large enough.
If not, the compressor will not be able to operate cause of voltage drop abnormally at starting.
- (4) Check to ensure that the earth wire is connected.
- (5) Install a main switch multi-pole main switch with a space of 1/7 in. (3.5mm) or more, single phase main switch with a space of 1/8 in. (3.0mm) or more between each phase. Please use the special three-phase power switch for 3-Phase product.
- (6) Check to ensure that the electrical resistance is more than 2 MΩ, by measuring the resistance between ground and the terminal of the electrical parts.
If not, do not operate the system until the electrical leakage is found and repaired.

Electrical wiring diagram

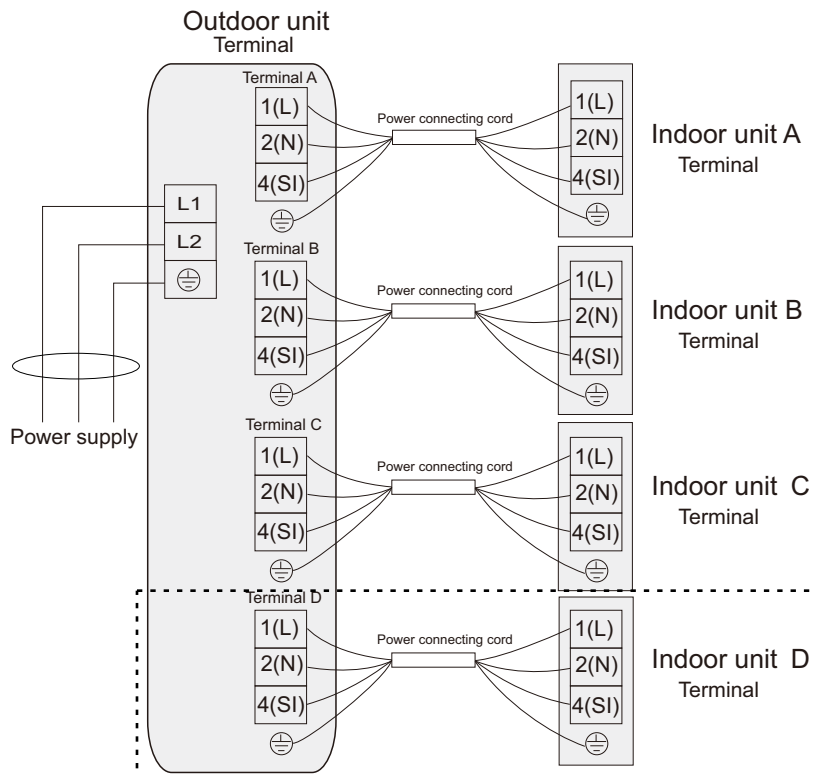

Note: For some indoor units

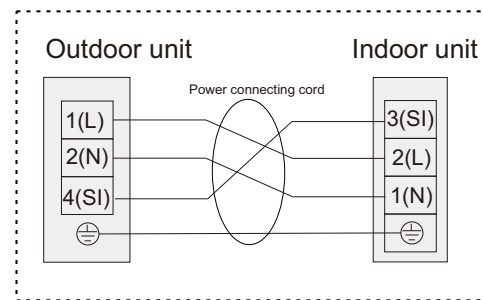

Note:
Terminal within the dotted line is only valid for 36K model.

Installation instructions

Wires connect steps:

24K

- (1) Valve cover removal
Remove the two mounting screws.
Remove the valve cover as shown by the arrow mark.
- (2) Fasten the power supply cable and the connection cable to the conduit holder using the lock nut.
- (3) Connect the power supply cable and the connection cable to terminal.
- (4) Fasten the power supply cable and the connection cable with the cable clamp.
- (5) Be sure to seal the holes with electrical putty.
Place the cables side to side. (Do not overlap the cables.)
- (6) Put the service cover and valve cover back after completion of the work.

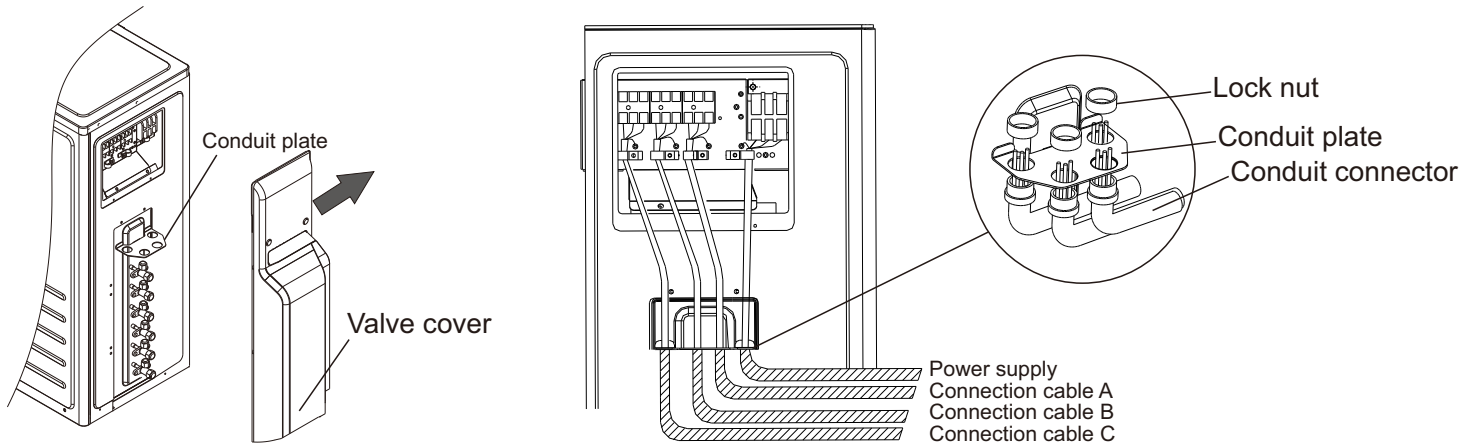

36K

- (1) Gently knock off 5 conductor holes on right side plate.
- (2) Unscrew the screws on maintenance plate, and remove it as shown by the arrow mark.
- (3) Fasten the power supply cable and the connection cable through conductor hole using the lock nut.
- (4) Connect the power supply cable and the connection cable to terminal.
- (5) Fasten the power supply cable and the connection cable with the cable clamp.
- (6) Be sure to seal the holes with electrical putty.
Place the cables side to side. (Do not overlap the cables.)
- (7) Put the maintenance plate back after completing the work.

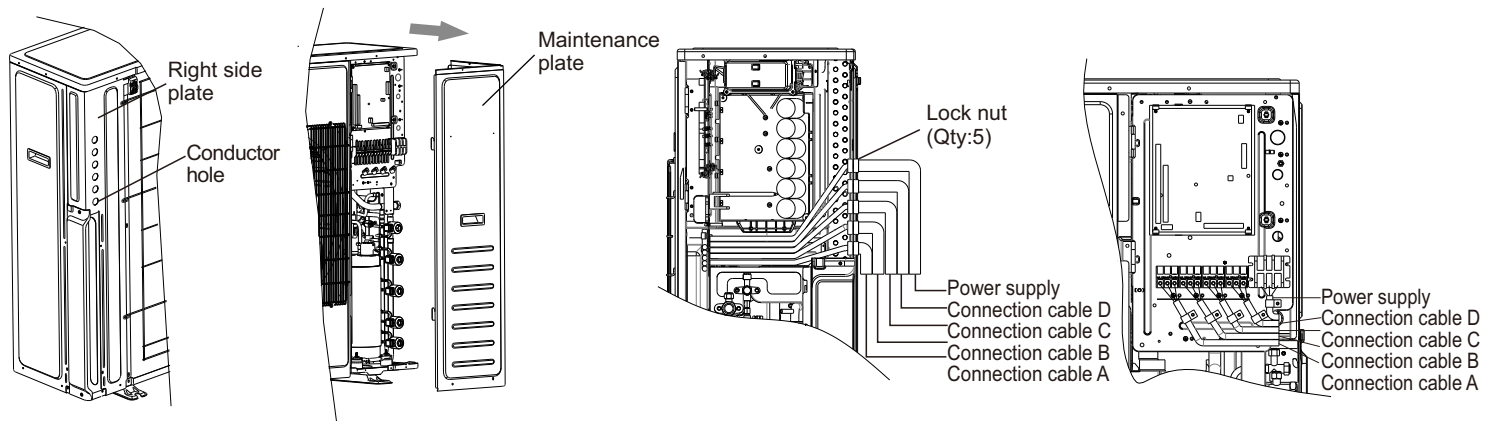

Installation instructions

Electrical Data

Model Capacity	Power Supply	ELB		Power Source Cable Size	Transmitting Cable Size	Circuit Breaker(A)
		Nominal Current (A)	Nominal Sensitive Current (mA)			
24K	208/230V ~, 60Hz	30	30	12 AWG 2cable+Ground	16 AWG 3 cable+Ground	30
36K	208/230V ~, 60Hz	40	30	10 AWG 2cable+Ground	16 AWG 3 cable+Ground	40

Max. Running Current (A): REFER TO NAMEPLATE

Note:

- (1) Follow local codes and regulations when selecting field wires and all the above are the minimum wire size.
- (2) When transmitting cable length is more than 49-1/5 ft. (15 m), a larger wire size should be selected.
- (3) Install main switch and ELB for each system separately. Select the high response type ELB that is acted within 0.1 second.

<Attentions when Connect the power supply wiring>

1. When connecting the terminal block using stranded wire, make sure to use the round crimp-style terminal for connection to the power supply terminal block. Place the round crimp-style terminals on the wires up to the covered part and secure in place.
2. When connecting the terminal block using a single core wire, be sure to perform curing.

Installation instructions

Trial Run

Trial run should be performed after refrigerant piping, drain, wiring, etc. have been finished.



The air-conditioner is provided with a crankcase heater, check to ensure that the switch on the main power source has been ON for more than 6 hours ahead of power on preheating, otherwise it might damage the compressor!

Do not operate the system until all the check points have been cleared.

- (A) Check to ensure that the stop valves of the outdoor unit are fully opened.
- (B) Check to ensure the electric wires has been fully connected.
- (C) Check to ensure that the electrical resistance is more than 2 MΩ, by measuring the resistance between ground and the terminal of the electrical parts. If not, do not operate the system until the electrical leakage is found and repaired.

Trial run function identification

Operate remote controller turn ON, then proceed trial run.

Do not touch any of the parts by hand at the discharge gas side, since the compressor chamber and the pipes at the discharge side are heated higher than 194°F (90°C).

- Turn off the power after trial run is finished.
Installation of the appliance is generally finished after the above operations are done. If you still have any trouble, please contact local technical service center of our company for further information.

