

This Owner's Manual is provided and hosted by [Appliance Factory Parts](#).



DIAL 18000Z-DUC-I Owner's Manual

[Shop genuine replacement parts for DIAL
18000Z-DUC-I](#)



[Find Your DIAL Air Conditioner Parts - Select From 23 Models](#)

----- Manual continues below -----



USE AND INSTALLATION INSTRUCTIONS

Thank you very much for purchasing this Air Conditioner. Please read these **Use and Installation Instructions** carefully before installing and using this appliance. And keep this manual for future reference.

Attention: If you are experiencing difficulty with your mini-split air conditioner, do not return it to the place of purchase. Contact Dial Manufacturing for help or disposition.

ÖaãT ađ ~ æc iã * ÆQ&E
G ÁU[~ cã F•cã ^ ÆU@^} a ÆZÁ i € H
Fã €€H €ÖÖS/ãã • d { ^•^!çã^O áãã ~ ÆU {

Caution Statements	1
Composition of the Air-Conditioner	3



Before Operation

Special Remarks	4
Troubleshooting	4

Installation and Maintenance

1. Safety Notice.....	6
2. The Tools and Instruments for Installation	7
3. The Installation of the Indoor Unit	7
3.1 The Initial Check	7
3.2 Installation	8
4. Refrigerant Pipe	10
4.1 The Pipe Material	10
4.2 The Connection of the Pipe	10
5. Drain Piping.....	11
6. Electrical wiring	12
6.1 General check	12
6.2 Change of Static Pressure	13
6.3 Electrical Installation	14
7. Trial run	14

Alert Symbols:

-  **DANGER** : The symbol refers to a hazard which can result in severe personal injury or death.
-  **WARNING** : The symbol refers to a hazard or an unsafe practice which may result in severe personal injury or death.
-  **CAUTION** : The symbol refers to a hazard or an unsafe practice which may result in personal injury, product or property damage.
- NOTE** : It refers to the remarks and instruction to the operation, maintenance, and service.

- This air-conditioner should be installed properly by qualified personnel in accordance with the installation instructions provided with the unit.
- Before installation, check if the voltage of the power supply at installation site is the same as the voltage shown on the nameplate.

 **DANGER**

- You must not alter this product in any way, otherwise, it may cause water leakage, breakdown, short-circuit, electric shock or fire may occur.
- Piping, welding and other such work should be carried out far away from any flammable explosive material, including the air-conditioner refrigerant, to guarantee the security of the site.
- To protect the air-conditioner from heavy corrosion, avoid installing the outdoor unit where sea water can splash directly onto it or in sulphurous air near a spa. Do not install the air-conditioner where excessively high heat-generating objects are placed.

 **WARNING**

- If the supply cord is damaged, it must be replaced by the factory or an authorized contractor in case of danger.
- The place where this product is installed must have reliable electrical grounding and protection. Please do not connect the grounding of this product to air-feeding ducts, drain piping, lightning protection facility as well as other piping lines to avoid receiving an electric shock and damages caused by other factors.
- Wiring must be done by a qualified electrician. All the wiring must comply with the local electrical codes.
- Consider the capacity of the electric current of your electrical meter and socket before installation.
- The power source where this product is installed should have an independent protection device and electric current over-load protection device, both of which are provided for this product.
- This appliance can be used by children aged 8 years and above and persons with reduced physical, sensory or mental capabilities or lack of experience and knowledge if they have been given supervision or instruction concerning use of the appliance in a safe way and understand the hazards involved. Children shall not play with the appliance. Cleaning and user maintenance shall not be made by children without supervision. Means for
- disconnection, which can provide full disconnection in all poles, must be incorporated in the fixed wiring in accordance with the wiring rules .

- **Read this manual carefully before using this air-conditioner. If you still have any difficulties or problems, consult your dealer for help.**
- **The air-conditioner is designed to provide you with comfortable room conditions. Use this unit only for its intended purpose as described in this instruction manual.**

CAUTION Statements

WARNING

- Never use gasoline or flammable gas near the air-conditioner, which is very dangerous.
- When air conditioner operation is abnormal, such that a burning smell, deformation, fire or smoke are detected, it is forbidden to continue using the air conditioner, the main power switch of the air conditioner must be cut off immediately and the manufacturer should be contacted.

CAUTION

- Do not turn the air-conditioner on and off from the main power switch. Use the ON/OFF operation button.
- Do not stick anything into the air inlet and air outlet of both the indoor and outdoor units. This is dangerous because the fan is rotating at a high speed.
- Details of type and rating of circuit breakers / ELB are detailed in outdoor instruction manual.
- The method of connection of the appliance to the electrical supply and interconnection of separate components are detailed in below part.
- The wiring diagram with a clear indication of the connections and wiring to external control devices and supply cord is detailed in below part. A cord of the H07RN-F type or the electrically equivalent type must be used for power connection and interconnection between outdoor unit and indoor unit. The size of the cord is detailed in below part.
- The dimensions necessary for correct installation of the appliance including the minimum permissible distances to adjacent structures is detailed in below part.
- The range of external static pressures for ducted appliances is detailed in below part.
- The indoor unit can only supply air to one room, it is not allowed to supply air to multiple rooms.

NOTE:

- **Storage condition:** Temperature -13~140°F (-25~60°C)
Humidity 30%~80%

Indoor unit

9K~18K

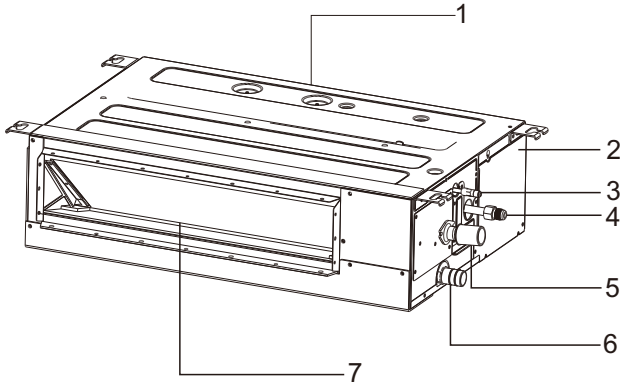

1. Air inlet
2. Electric box
3. Refrigerant pipe (Liquid)
4. Refrigerant pipe (Gas)
5. Drain pipe (Connect with pump)
6. Drain pipe
7. Air outlet

Remote controller(optional)

You can control the air-conditioner with the wire remote controller or wireless remote controller.

It is used for controlling power ON/OFF, setting the running mode, temperature, fan speed and other functions. There are different types of remote controllers that can be used.

Operation instructions will be further specified in remote controller's manual.

Please read it carefully before using this appliance and keep it for future reference.

Wire remote controller

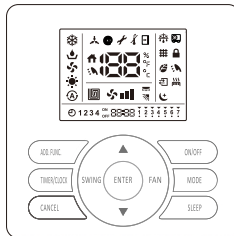

Wireless remote controller



Note: The figures are based on the external views of the standard model.

Consequently, the shape may differ for the air conditioner model you have selected.

Special remarks

- 3 minutes protection after compressor stops
To protect compressor, it will remain off for at least 3 minutes once it has stopped.
- 5 minutes protection when the compressor is running
The compressor must run for at least 5 minutes once it is started. During that 5 minutes, compressor will not stop even the room temperature reaches the setting temperature point unless you use remote controller to turn off the unit (all indoor unit can be turned off by user).
- Cooling operation
The fan of the indoor unit will never stop running in cooling operation. It continues to operate even if the compressor stops working.
- Heating operation
Heating capacity depends on external factors like outdoor unit temperature. Heating capacity might decrease if outdoor ambient temperature is too low.
- Anti-freezing function during cooling
When the temperature of the air from the indoor outlet is too low, the unit will run for some time under the fan mode, to avoid frost or ice forming on the indoor heat exchanger.
- Cold air prevention
For several minutes after the heating mode is started, the fan of the indoor unit will not run until the heat exchanger of the indoor unit reaches a certain temperature to prevent cold draft.
- Defrosting
When the outdoor temperature is too low, frost or ice may form on the outdoor heat exchanger, reducing heating performance. When this happens, a defrosting system will operate. During this time the fan in the indoor unit stops (or runs at a very low speed in some cases), to prevent cold draft. After defrosting is over, the heating operation and fan speed restart.
- Evacuation of residual air
When stopping the air conditioner in normal operation, the fan motor will run with low speed for a while to blow out the residual heating air.
- After power outage
When the power supply recovers after a power outage, all presets will still be effective and the air-conditioner will run according to the previous setting.

Troubleshooting



If the trouble persists even after checking the following, contact Dial Manufacturing and inform them of the items. according to the original setting.

1. Unit Does Not Operate
Check whether the SET TEMP is set at the correct temperature.
2. Not Cooling or Heating properly
 - Check for obstruction of air flow in indoor and outdoor units.
 - Check if too many heating sources are located in the room.
 - Check if the air filter is clogged with dust.
 - Check if the doors or windows are open.
 - Check if the temperature condition is not within the operation range.
3. The Following Conditions are Not Abnormal
 - Odour from indoor unit
Unpleasant odor detected from indoor unit after a long period of time. Clean the air filter and panels or allow a good ventilation.
 - Sound from Deforming Parts
During system start or stop, a sound might be heard. This is due to thermal deformation of plastic parts.
 - Steam from Outdoor Heat Exchanger
During defrosting operation, ice on the outdoor heat exchanger melts resulting in steam.
 - Dew on Air Panel
When the cooling operation continues for a long period of time under high humidity conditions, dew may form on the air panel, please set the appliance at high fan speed and adjust louvers to the max. angle.
 - Refrigerant Flow Sound
While the system is being started or stopped, sound from the refrigerant flow may be heard.

5. Mode Interference (Only for multi-split)

Because all indoor units use the same outdoor unit and the outdoor unit can only run with one mode of operation at a time (cooling or heating), mode interference will occur when an indoor unit is set to a different operating mode than the operating mode of the outdoor unit and other indoor units. The following shows the mode interfere scene.

	Cooling	Dry	Heating	Fan	
Cooling	√	√	×	√	√ --- normal
Dry	√	√	×	√	×
Heating	×	×	√	×	×
Fan	√	√	×	√	×

The outdoor unit will always run according to the mode of first indoor unit that is turned on. When the setting mode of one of the other indoor units causes mode interference, 3 beeps will be heard, and the indoor unit that caused the interference will turn off automatically.

1. Safety Notice

WARNING

- Installation should be performed by a qualified personnel. (Improper installation may cause water leakage, electrical shock or fire.)
- Install the unit according to the instructions given in this manual. (Incomplete installation may cause water leakage, electrical shock or fire).
- Be sure to use the supplied or specified installation parts. (Use of other parts may cause the unit to get loosened, water leakage, electrical shock or fire).
- Install the air conditioner on a solid base that can support the unit weight. (An inadequate base or incomplete installation may cause injury if the unit falls off the base).
- Electrical work should be carried out in accordance with the installation manual and the local national electrical wiring rules or code of practice. (Insufficient capacity or incomplete electrical work may cause electrical shock or fire).
- Be sure to use a dedicated power circuit. (Never use a power supply shared by another appliance).
- For wiring, use a cable long enough to cover the entire distance. Do not use an extension cord.
- Do not put other loads on the power supply, use a dedicated power circuit.
- Use the specified types of wires for electrical connections between the indoor and outdoor units. (Firmly clamp the interconnecting wires so their terminals receive no external stresses).
- Incomplete connections or clamping may cause terminal overheating or fire.
- After connecting all the wires be sure to fix the cables so that they do not put undue force on the electrical covers or panels. (Install covers over the wires, incomplete cover installation may cause terminal overheating, electrical shock or fire).
- When installing or relocating the system, be sure to keep the refrigerant circuit free from air (Air in the refrigerant circuit may causes abnormal pressure rise or rupture, resulting in injury).
- If any refrigerant has leaked out during installation, ventilate the room.
- After installation is complete, check to make sure that no refrigerant is leaking out. (The refrigerant produces a toxic gas if exposed to flames).
- When carrying out piping connection, take care not to let air substances other than the specified refrigerant get into refrigeration cycle. (Otherwise, it will cause lower performance, abnormal high pressure in the refrigeration cycle, explosion and injury).
- Make sure that the installation is properly grounded. Do not ground the unit to a utility pipe, lightning arrester, or telephone grounding. Incomplete grounding may cause electrical shock. (A high surge current from lightning or other sources may cause damage to the air conditioner).
- An earth leakage circuit breaker may be required depending on the site condition to prevent electrical shock.
- Disconnect the power supply before wiring, piping, or checking the unit.
- When moving the indoor unit and outdoor unit, please be careful, do not cause the outdoor unit to tilt over 45 degrees.
- Pay attention to the sharp edges of the air conditioner to avoid any injury.
- During remote controller installation, ensure that the length of the wire between the indoor unit and remote controller is within 131 ft. (40m).

CAUTION

- Do not install the air conditioner in a place where there is danger of exposure to flammable gas leakage. (If the gas leaks and builds up around the unit, it may catch fire).
- Establish drain piping according to the instructions in this manual. (Inadequate piping may cause flooding).
- Tighten the flare nut according to the specifications with a torque wrench. (If the flare nut is tightened beyond specified torque, the flare nut may crack after a long time and cause refrigerant leakage).

2. The Tools and Instruments Needed for Installation

Number	Tool	Number	Tool
1	Standard screwdriver	8	Knife or wire stripper
2	Vacuum pump	9	Level
3	Charge hose	10	Hammer
4	Pipe bender	11	Power drill
5	Adjustable wrench	12	Tube expander
6	Pipe cutter	13	Hexagon key set
7	Cross head screw-driver	14	Measuring tape

3. The Installation of the Indoor Unit

▲ CAUTION

During installation, do not damage the insulation material on the surface of the indoor unit.

3.1 The Initial Check

▲ CAUTION

- When moving the unit after unpacking, make sure to lift it by holding its lifting lugs. Do not exert any pressure on other parts, especially the refrigerant piping, drain piping and flange parts.
- Wear protective gear when installing the unit.

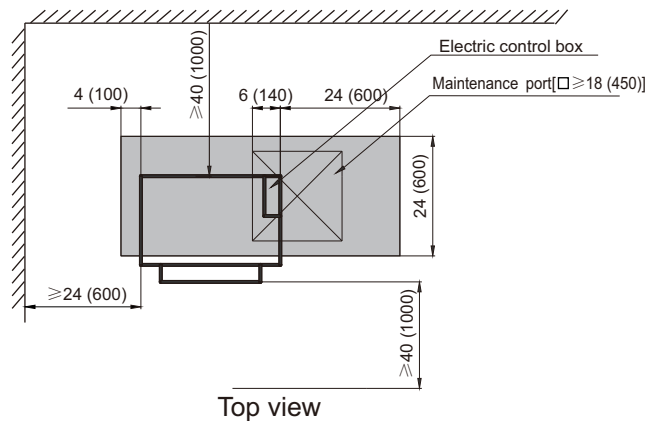

1. Provide necessary maintenance port when the ceiling is not detachable.
2. The location of the maintenance port should allow removal of the electric box cover and internal components are all easy to perform.

9K~18K

Fig. 3.1.1 [unit: in. (mm)]

3.1 The Initial Check cont.

- Optimum air distribution is ensured.
- The air passage is not blocked.
- Condensate can drain properly.
- The ceiling is strong enough to bear the weight of the indoor unit.
- The false ceiling is not at an incline.
- Sufficient clearance for maintenance and servicing is ensured. (See Fig.3.1.1)
- Piping between the indoor and outdoor units is within the allowable limits. (refer to the installation of the outdoor unit)
- The indoor unit, outdoor unit, power supply wiring and transmission wiring must be kept at least 1 meter away from televisions and radio, this prevents image interference and noise in electrical appliances. (Noise may be generated depending on the conditions under which the electric wave is generated, even if a one-meter allowance is maintained.)
- Do not install the indoor unit in a machinery shop or kitchen where the indoor unit may be exposed to oil or oil containing mist. The oil will deposit on the heat exchanger, reducing the performance of the indoor unit and may deform, and in the worst case, break the plastic parts of the indoor unit.
- Use suspension bolts to install the indoor unit, check whether or not the ceiling is strong enough to support the weight of the unit. If there is a risk that the ceiling is not strong enough, reinforce the ceiling before installation.
- For bottom intake installations, replace the chamber lid and the intake-side flange using the procedure displayed below.
 - (1) Remove the intake-side flange, then remove the chamber lid. Refer to Fig. 3.1.2 for the directions.
 - (2) Reattach the removed chamber lid in the orientation shown in Fig. 3.1.3, reattach the removed intake-side flange in the orientation as shown in Fig. 3.1.3.

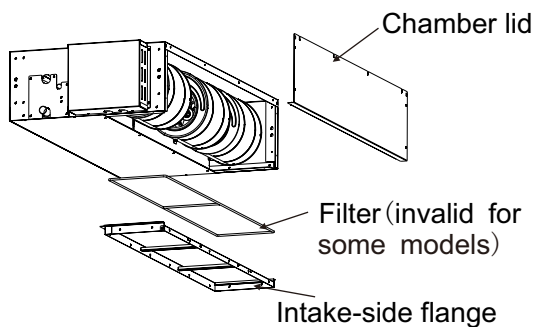
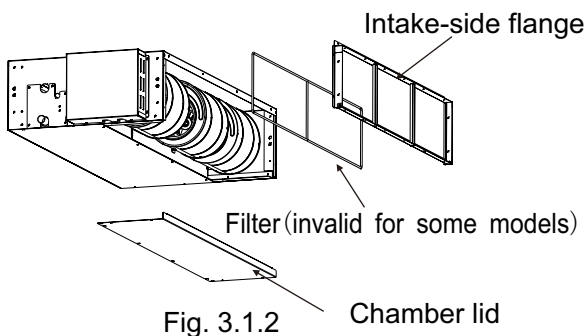

Fig. 3.1.3

Installation and Maintenance

3.2 Installation

3.2.1 Suspension bolts

- (1) Consider the pipe direction, wiring and maintenance carefully, and choose the proper direction and location for installation.
- (2) Install the suspension bolts as shown in Fig. 3.2.1 below.

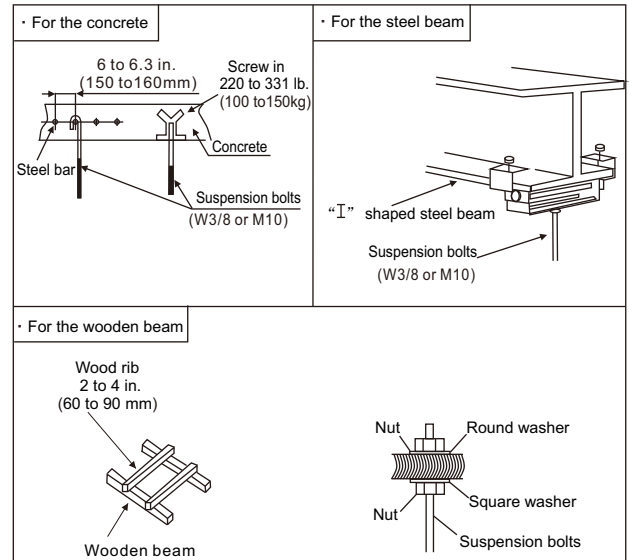
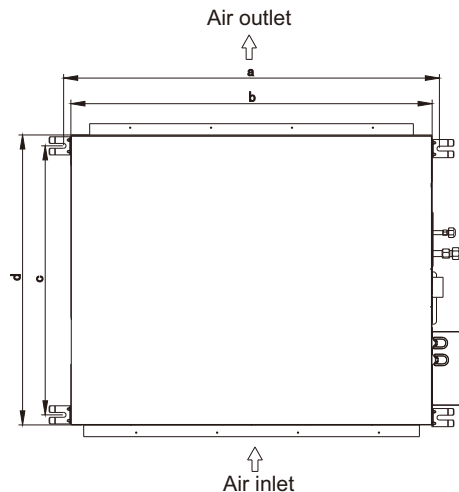

Fig. 3.2.1 Fixing the suspension bolts

3.2.2 The position of the suspension bolts and the pipes

- (1) Mark the positions of the suspension bolts, the positions of the refrigerant pipes and the drain pipes.
- (2) The dimension are shown below.



[Unit: in. (mm)]

Model (Cooling capacity)	a	b	c	d
9K/12K	37-5/6 (961)	35-62/75 (910)	14-42/55 (375)	17-3/5 (447)
18K	48-13/28 (1231)	46-21/46 (1180)	14-42/55 (375)	17-3/5 (447)

Fig. 3.3 Suspension bolts

3.2.3 Install the indoor unit.

The installation of the indoor unit is shown in Fig. 3.4.

Suspension bolts (4-M10 or W3/8)
(Field supplied)

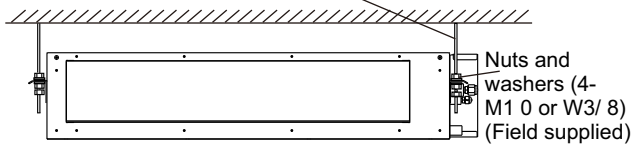

Fig. 3.4 The installation of the indoor unit

(1) How to fix the suspension bolts and the nuts
As shown in the figures 3.5, the nuts are fixed four bolts.

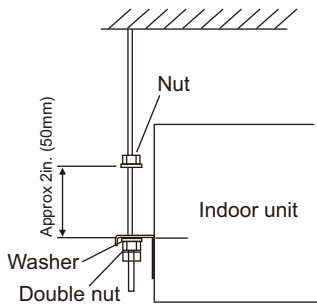

Fig. 3.5 Suspension bolts and nuts

(2) Install the indoor unit

- As shown in the following figure, place the left hanger bracket on the nuts and washers of the suspension bolts.
- Make sure that the left hanger bracket has been fixed on the nuts and washers securely, install the right hanger bracket suspension hook on the nuts and washers.
(When installing the indoor unit, you can slightly remove the suspension bolts.)

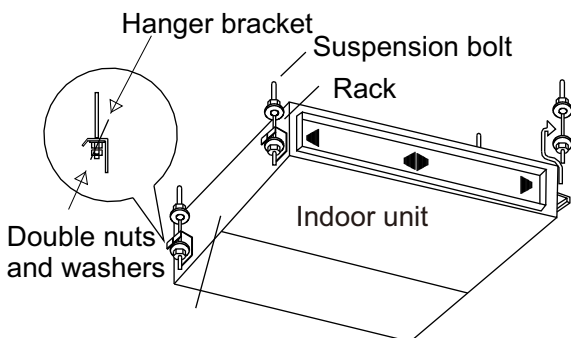

Fig. 3.6

3.2.4 Adjusting of the unit level

- (1) Check to ensure that the foundation is flat, taking into account the maximum foundation gradient.
- (2) The unit should be installed so that the drainage side is slightly [0 in.~ 0.2 in. (0mm~5mm)] lower than other sides for adequate drainage.

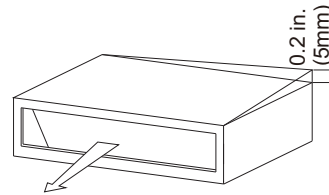

Fig. 3.7

- (3) After the adjustment, tighten the nuts and swear the thread locker on the suspension to prevent the nuts from loosening.

▲ CAUTION

- (1) During the installation, please cover the unit with the plastic cloth to keep it clean.
- (2) Use a level to ensure that the unit is installed level and is not sloping away from the drain piping.

3.2.5 Installing the duct

▲ CAUTION

- Make sure the external static pressure of the unit is within the range.
- Connect the duct and intake-side flange.
- Connect the duct and outlet-side flange.
- The connection of indoor unit and air duct must be well sealed and kept warm with insulation material.

Example

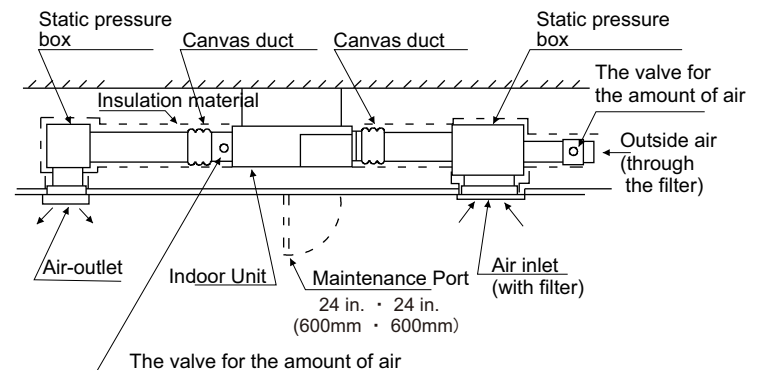

4. Refrigerant Pipe

▲ DANGER

Use the refrigerant specified on the outdoor nameplate. When conducting the leakage check, do not mix in oxygen, acetylene and, flammable and virulent gas, as these gases are quite dangerous, and may possibly cause explosion. It is suggested that the nitrogen be used to perform these experiments.

4.1 The Pipe Material

- (1) Choose dustless, non-humid, clean copper pipe. Before installing the pipe, use nitrogen or dry air to blow away the tube dust and impurity.
- (2) Choose the copper pipe according to Fig. 4.2.

4.2 The Connection of the Pipe

- (1) The connection positions of the pipe are shown in Fig. 4.1 and Fig. 4.2.

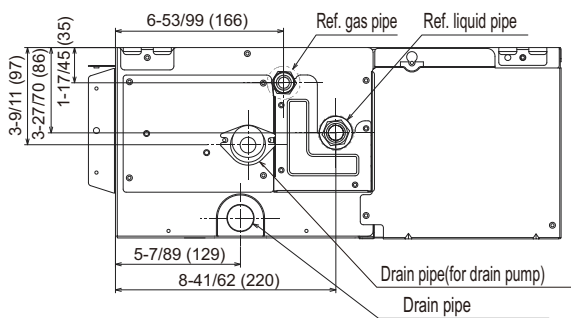

9K~18K

Unit: in. (mm)

Fig. 4.1 The connection positions of the pipe

Model (Btu/h)	Gas Pipe [in. (mm)]	Liquid Pipe [in. (mm)]
9K~12K	ø 3/8 (9.52)	ø 1/4 (6.35)
18K	ø 1/2 (12.7)	ø 1/4 (6.35)

Fig. 4.2 The pipe diameter

- (2) As shown in Fig. 4.3, screw up the nuts with 2 spanners.

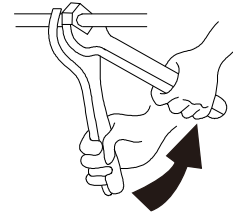

Tube size [in. (mm)]	Torque [lbf-ft. (N·m)]
ø 1/4 (6.35)	14.8 (20)
ø 3/8 (9.52)	29.5 (40)
ø 1/2 (12.7)	44.3 (60)
ø 5/8 (15.88)	59.0 (80)
ø 3/4 (19.05)	73.8 (100)

Fig. 4.3 Tightening torque for the nut

- (3) After finishing connecting the refrigerant pipes, insulate them with the insulation material.

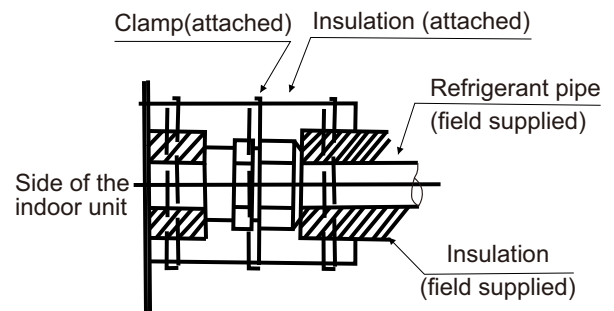
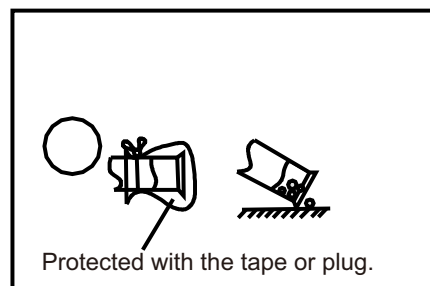

Fig. 4.4 Piping insulation procedure

▲ CAUTION

- Do not put the pipes on the floor directly.



5. Drain piping

Install the drain piping

- Make sure the drain works properly .
- Prepare PVC pipe with an inner diameter of 1 in. and an outer diameter of 1.3 in.
- The diameter of drain pipe connection hole should be same as that of the drain pipe.
- Keep the drain pipe short and sloping down wards at a gradient of at least 1/100 to prevent air pockets from forming.

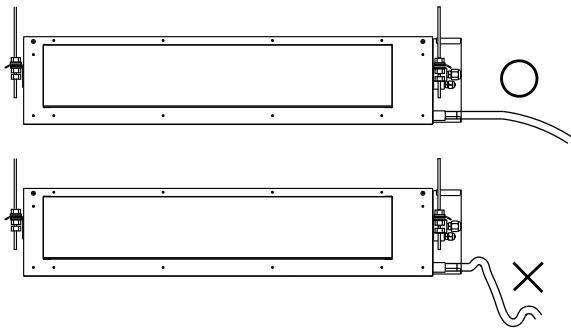

NOTE

When the relative humidity of inlet or ambient air exceeds 80%, apply an (field-supplied) auxiliary drain pan beneath the indoor unit as shown below.

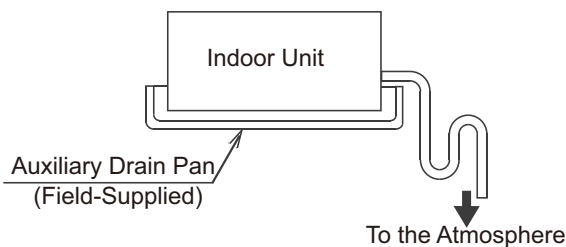

CAUTION

Water accumulation in the drain piping can cause the drain to clog.

- To keep the drain tube from sagging, use hanging wires every 3.3 ft. (1m) to 5.0 ft. (1.5m).
- Use the drain hose and the clamp. Insert the drain hose fully into the drain socket and firmly tighten the drain hose with the clamp.
- The two areas below should be insulated because condensation may occur there causing water leakage.
- Drain piping passing indoors
- Drain sockets.

- Referring the figure below, insulate the drain socket and drain hose using the included large sealing pad.

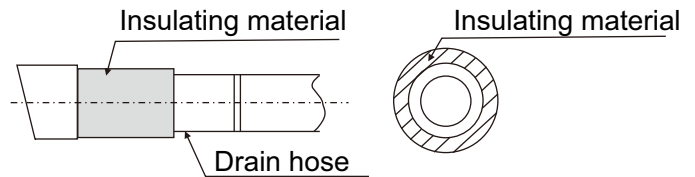

CAUTION

Drain piping connections

- Do not connect the drain pipes directly to sewage pipes to avoid ammonia odour. The ammonia in the sewage might enter the indoor unit through the drain pipes and corrode the heat exchanger.
- Do not twist or bend the drain hose, doing so applies excessive force applied on it and may also cause leakage.
- After piping work is finished, check if drainage flows smoothly.
- Gradually pour approximately 1000 cc of water from the outlet hole into the drain pan to check drainage flow.
- Check the drainage as shown below:

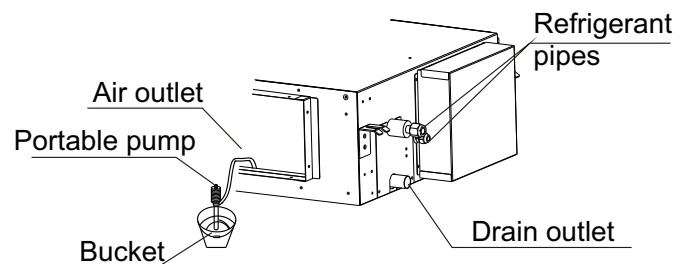

6. Electrical Wiring

6.1 General Check

⚠ CAUTION

- When clamping the wiring, use the included clamping material to prevent external pressure being exerted on the wiring connections and clamp firmly.
- While performing wiring work, make sure the wiring is proper and does not cause the control box lid to stick up, then close the cover firmly. When attaching the control lid, make sure you do not pinch any wires.
- Outside the indoor unit and outdoor unit, separate the weak wiring (remote controller and transmission wiring) and strong wiring (ground and power supply wiring) at least 2 in. (50mm) so that they do not pass through the same place together. Proximity may cause electrical interference malfunction and breakage.

⚠ WARNING

- If the fuses burn up, please contact Dial Manufacturing, Inc. Please do not replace it by yourself, as it may result in accident or electric shock.
- (1) Remove the screws and the electric box cover as shown in the Fig. 6.1.
 - (2) Pass connection cable and wired controller cable through the two holes on the conduit panel.
 - (3) Fasten the conduit connection to the conduit panel using the lock nut.
 - (4) Connect the connection cable and wired controller cable to the terminal.
 - (5) Tie the cable in the electric box with the clamp tightly.
 - (6) After completing the wiring, seal the wiring hole with the sealing material (with the lid) to prevent condensation and insects entering the control box.
 - (7) Put the electric box cover back after completion of the work.

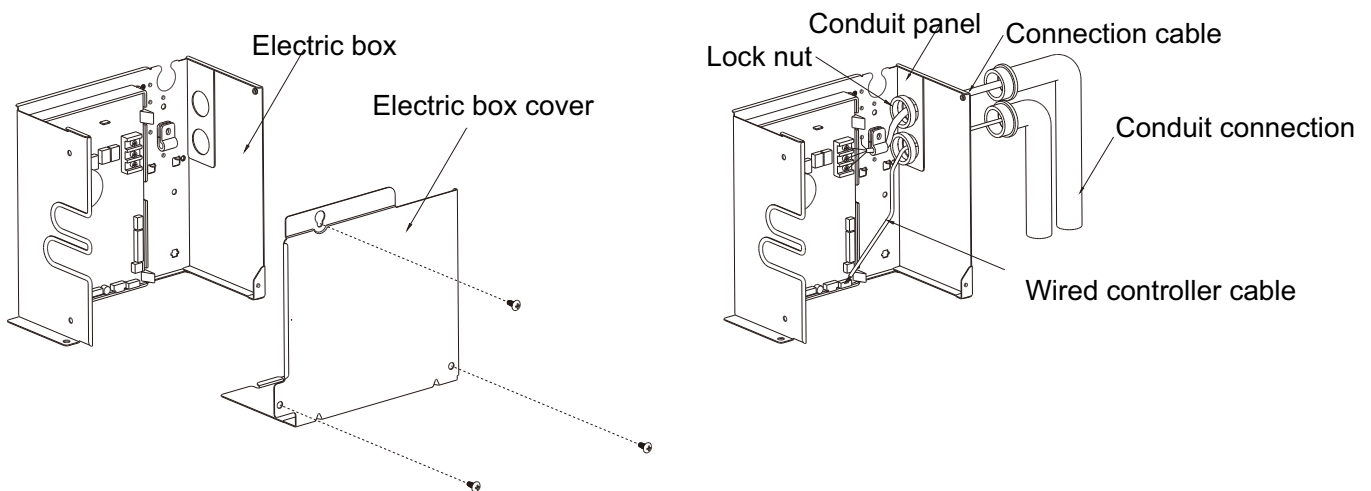
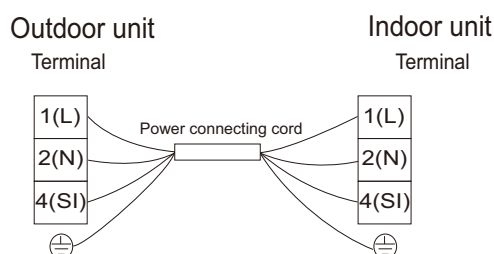

Fig.6.1

Electrical Wiring Diagram



6.2 Change of Static Pressure

The static pressure can be freely adjusted by using specific wire remote controller.

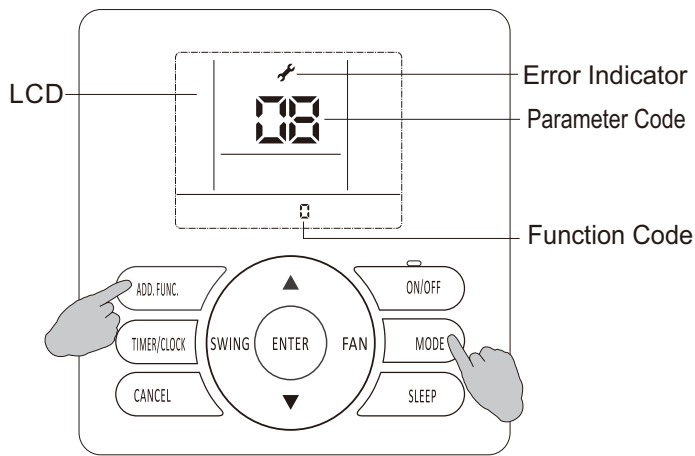

Fig 6.2

Model (Capacity Btu/h)	The range of static pressure	Function code set
9K/12K/18K	0-0.015 in.Hg (0-50Pa)	0-50 function code value equals static pressure value, more than 50 is 0.015 in.Hg (50Pa), [default: 0 (0 in.Hg or 0 Pa)]

Static pressure setting:

- 1 Hold down both "MODE" button and "ADD.FUNC." button for 3 seconds, symbol and parameter code blinking at the same time.
- 2 Press "▲/▼" button to adjust parameter number until display "17", and press "ENTER" button to entering system parameter adaption state, symbol stop blinking.
- 3 Select desired parameter code 10 by pressing "▲/▼" button, and press "ENTER" button to confirm.
- 4 Select desired function code to rewrite the parameter values by pressing "▲/▼" button, and press "ENTER" button to confirm.
- 5 Press "ON/OFF" button or "CANCEL" button to quit.

If you still have any trouble, please contact Dial Manufacturing, Inc. for further information.

6.3 Electrical Installation

WARNING

- Use an ELB (Earth Leakage Breaker). If not used, electric shock or a fire may result.
- Do not operate the system until all the check points have been cleared.
 - (A) Check to ensure that the insulation resistance is more than 2MΩ, by measuring the resistance between ground and the terminal of the electrical parts. If not, do not operate the system until the electrical leakage is found and repaired.
 - (B) Check to ensure that the stop valves of the outdoor unit are fully opened and then start the system.
- **Pay attention to the following items while the system is running.**
 - (A) Do not touch any of the parts by hand at the discharge gas side, since the compressor chamber and the pipes at the discharge side are heated higher than 194°F(90°C).
 - (B) **DO NOT PUSH THE BUTTON OF THE MAGNETIC SWITCH (ES).**

Model Capacity(Btu/h)	Transmitting Cable Size
9K~18K	4×16AWG

Note:

- (1) Follow local codes and regulations when selecting field wires, and ensure all the above are the minimum wire size.
- (2) Use copper supply wires.
- (3) When transmitting cable length is more than 49-1/5 ft. (15m), a larger wire size should be selected.
- (4) Install main switch and ELB for each system separately. Select the high response type ELB that is acted within 0.1second.

<Attentions when Connect the power supply wiring>

1. When connecting the terminal block using stranded wire, make sure to use the round crimp-style terminal for connection to the power supply terminal block. Place the round crimp-style terminals on the wires up to the covered part and secure in place.
2. When connecting the terminal block using a single core wire, be sure to perform curing.

7. Trial Run

Please perform trial run according to outdoor unit installation manual.

