

**FISHER & PAYKEL**

**BUILT IN DISHWASHER**

---

DW24U2I1 FP US CA

PRODUCT CODE: 81871-A

**PARTS MANUAL**

**US CA**

# CONTENTS

---

Introduction	2
Chassis & Tub components	3
Basket components	5
Spray Arm components	7
Base & flood components	11
Door components	13

# INTRODUCTION

---

<b>BRAND</b>	<b>VOLTAGE</b>	<b>MODEL</b>	<b>PRODUCT CODE</b>
Fisher & Paykel	120VAC 60Hz	DW24U2I1 FP US CA	81871-A

---

## MODELS

- The models covered by this manual are listed on the front cover.
- The information detailed in this manual is subject to change without notice. The latest version is indicated by the reprint date and replaces any earlier editions.

## KIT PARTS

Where a part number is shown against the descriptions for these kit components, they are also available as separate items. In addition, some parts may be supplied with these kits that are not available as separate items, and are therefore either not listed, or a part number is not shown against the part description in this manual.

## PARTS LIST KEY

<b>NI</b>	As a part reference, indicates the part is not illustrated on the diagram.
<b>NOT USED</b>	As a part number, indicates the diagram part reference is not used in this manual.
<b>NS</b>	As a part number, indicates the part is not servicable.

---

## US

Fisher & Paykel Appliances Inc.  
695 Town Center Drive, Suite 180  
Costa Mesa.  
CA 92626-1902  
USA

Customer Care: 1-888-936-7872  
Fax: (714) 372-7003  
email: [customer.care@fisherpaykel.com](mailto:customer.care@fisherpaykel.com)

# CHASSIS & TUB COMPONENTS

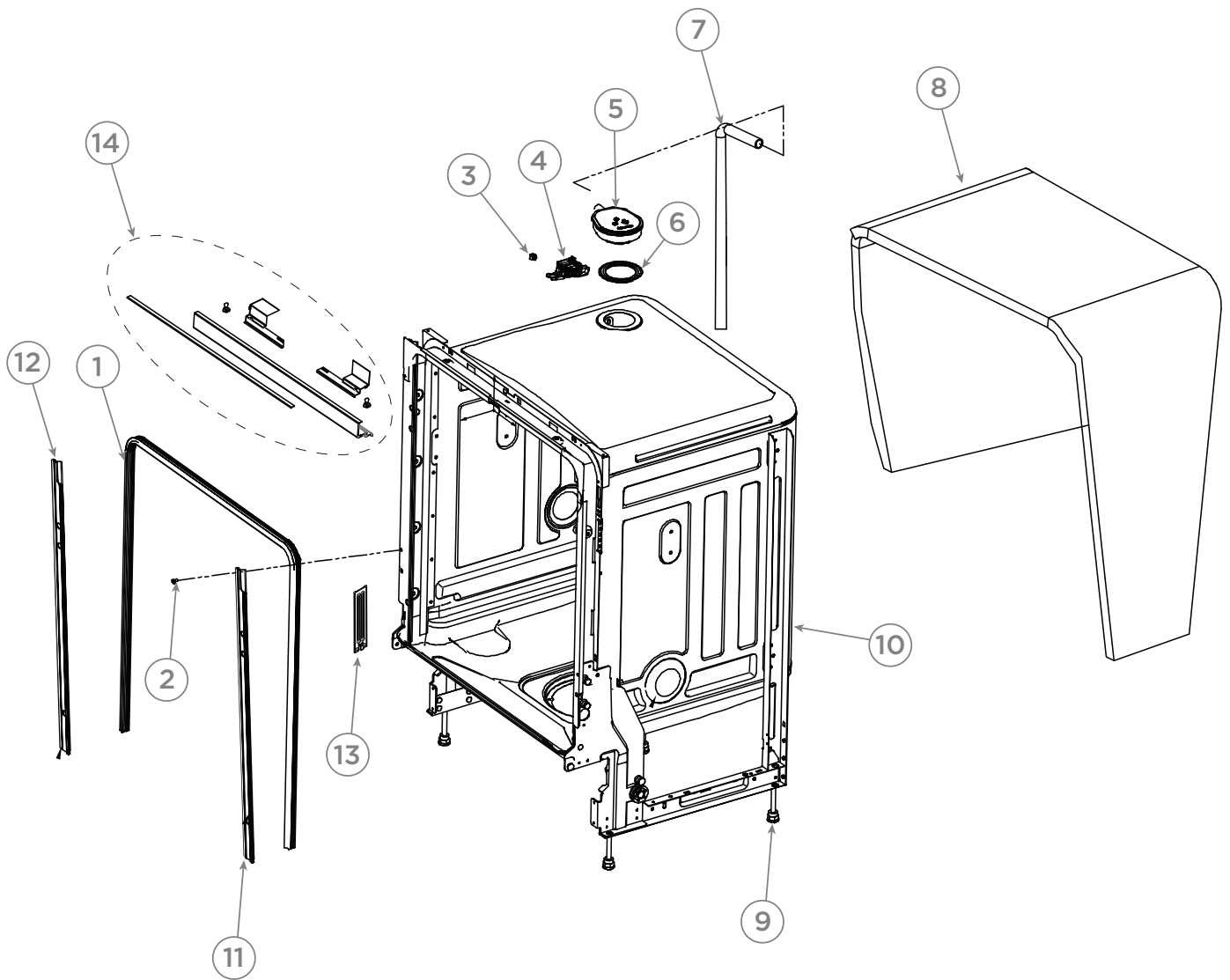

## CHASSIS & TUB COMPONENTS

REFERENCE	PART NUMBER	PART DESCRIPTION
1	H0120300248	GASKET TUB
2	H0077010022	SCREW ST3.5 17
3	H0120200393	PLUG
4	H0120801601	DOOR LOCK/HOOK ASSEMBLY
5	H0120802341	HOUSING THERMO DRY
6	H0120200605	GASKET SEALING
7	H0120200604	HOSE THERMO DRY
8	H0120300099C	FELT SOUND DEADENING SIDE/TOP
9	H012G1451092A	REAR FOOT ADJUSTABLE BUILT IN
10	NS	TUB ASSEMBLY
11	H0120201617B	GASKET TUB DOOR GASKET RIGHT
12	H0120201617C	GASKET TUB DOOR GASKET LEFT
13	H120102093	COVER
14	H0120805706	KIT BRACKET INFILL
	Includes	BRACKET-INFILL-CNTR-PC
	Includes	BRACKET-INFILL-RH
	Includes	BRACKET-INFILL-LH-PC

# BASKET COMPONENTS

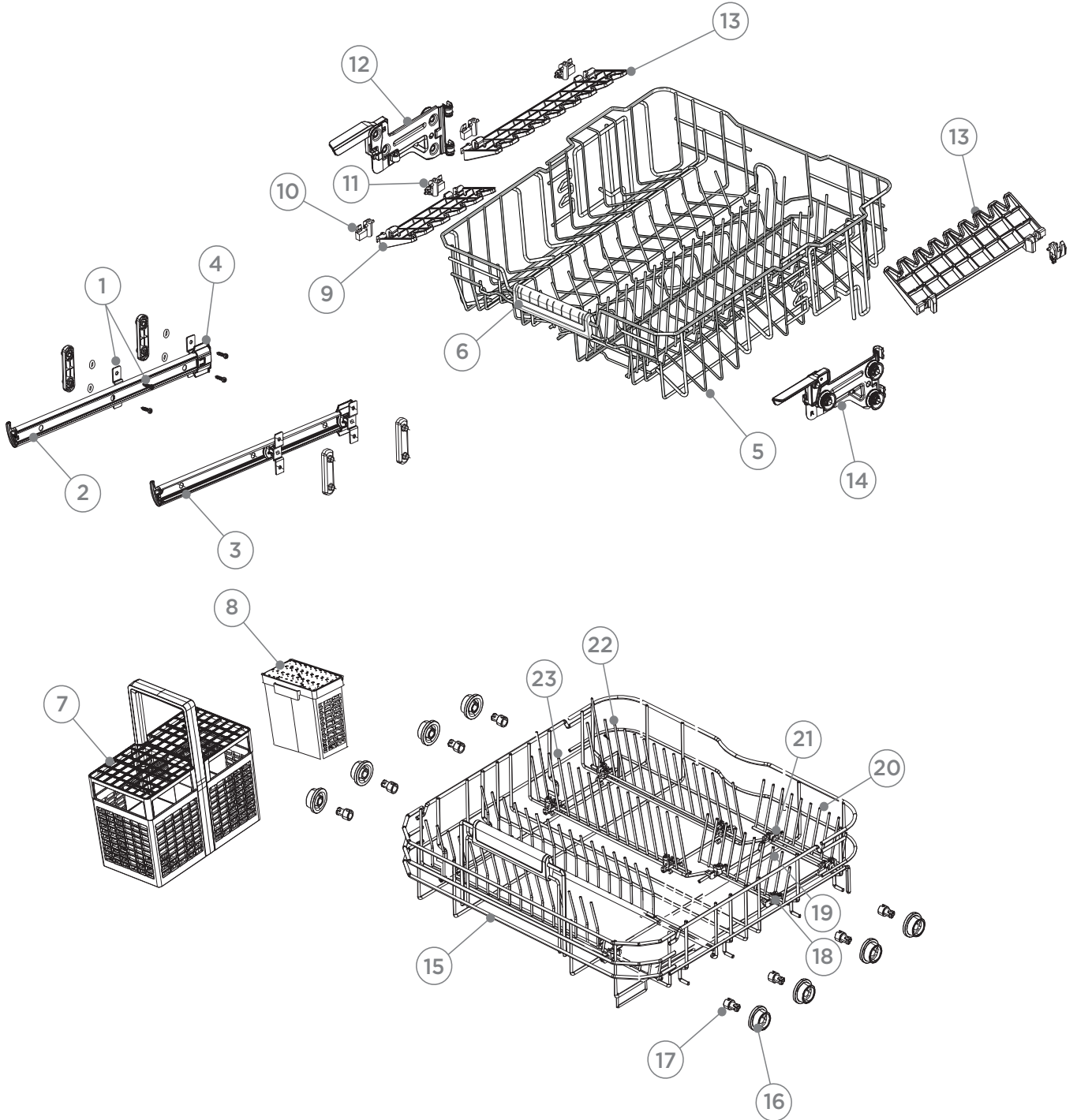

## BASKET COMPONENTS

REFERENCE	PART NUMBER	PART DESCRIPTION
1	H0120802832A	MID RAIL SUPPORT
2	H0120802954	MID RAIL LEFT
3	H0120802949	MID RAIL RIGHT
4	H0120201502	MID RAIL STOP BACK
5	H0120803057A	UPPER BASKET
6	H0120803302	HANDLE FRONT ASSY
7	H0120802868	CUTLERY BASKET
8	H0120802868A	CONTAINER CUTLERY BASKET
9	H0120201180	CUP RACK
10	H0120201180B	CUP RACK SUPPORT LEFT
11	H0120201180C	CUP RACK SUPPORT RIGHT
12	H0120802976	LIFTING MECHANIC LEFT
13	H0120201180A	CUP RACK BIG
14	H0120802975	LIFTING MECHANIC RIGHT
15	H0120803063	LOWER BASKET
16	H0120200377	WHEEL LOWER BASKET
17	H0120200324	AXLE STUB LOWER BASKET
18	H0120202827B	CLIP FOLD DOWN
19	H0120101082B	FOLD DOWN WIRE -2-LEFT
20	H0120101082C	FOLD DOWN WIRE 2 RIGHT
21	H0120202828B	CLIP FOLD DOWN
22	H0120101082	FOLD DOWN WIRE -1- RIGHT
23	H0120101082A	FOLD DOWN WIRE -1- LEFT

# SPRAY ARM COMPONENTS

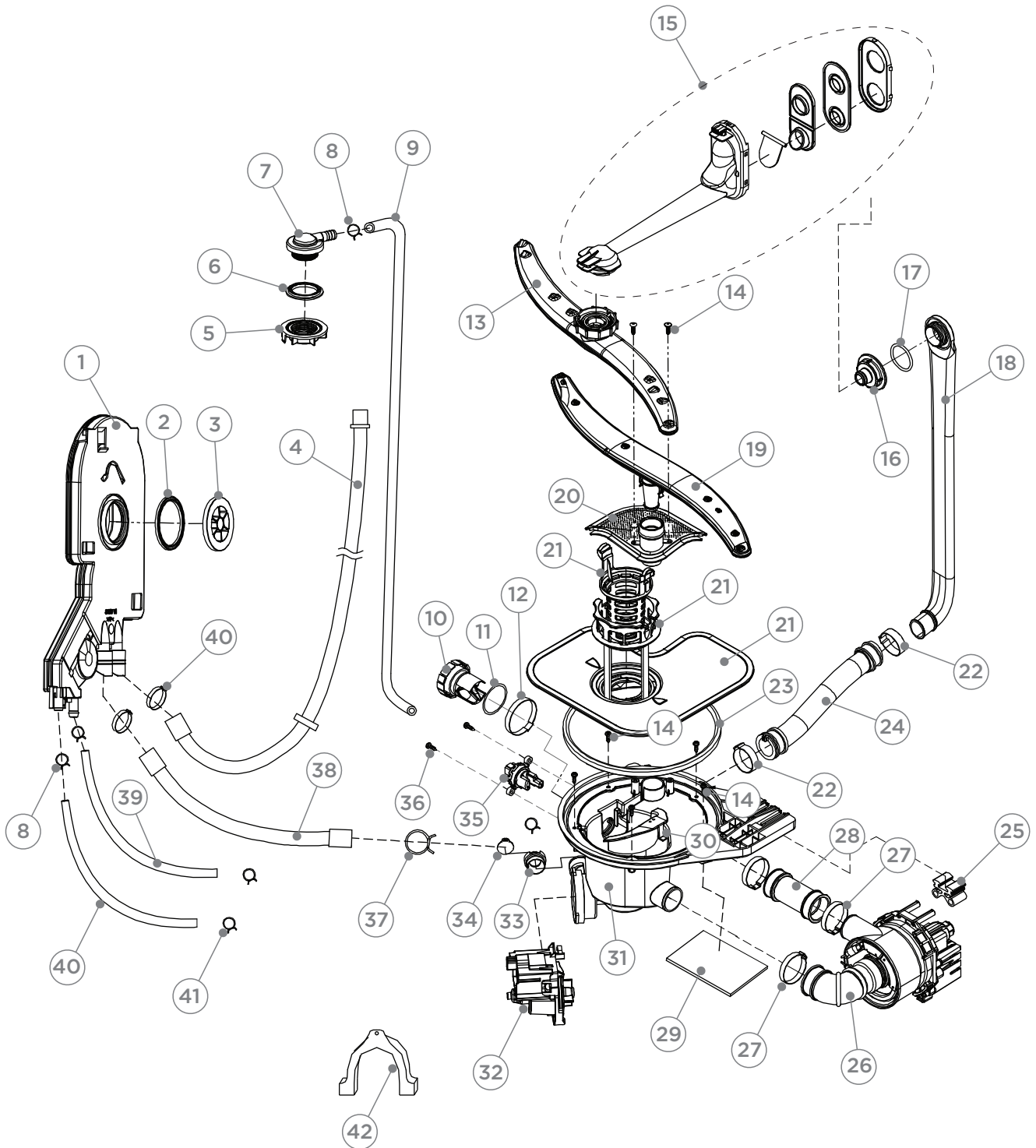



## SPRAY ARM COMPONENTS

REFERENCE	PART NUMBER	PART DESCRIPTION
1	H0120801702A	WEIR INCL FLOW METER
2	H0120200382	O-RING GASKET WEIR
3	H0120200401	NUT BREATHER RING WEIR
4	H0120201665A	HOSE DRAIN (LONG)
5	H0120201003	SPRAYER TOP
6	H0120301022	O RING GASKET
7	H0120202701	UPPER SPRAY BASE
8	H012G1040020	CLAMP HOSE
9	H0120301100G	HOSE TOP SPRAYER
10	H0120200396	COVER FOR SUMP
11	H012G4050157	O-RING AIR VENT
12	H0120600020	CLAMP HOSE
13	H0120202776A	SECOND SPRAYER ASSEMBLY
14	H0120600160	SCREW NST4.2 X 13
15	H0120801584C	KIT VALVE/HOUSING/HOSE/COVER
	Includes	TRANSITION TOP GREY
	Includes	VALVE FLAP UPPER SPRAYARM
	Includes	HOUSING FLAP VALVE
	Includes	SEAL TUBE TOP SPRAYARM
	Includes	COVER TOP TRANSITION GREY
16	H0120201630	BASE SECOND SPRAYER
17	H0120300212	O-RING DUCT
18	H0120201603A	OUTER DUCT CONNECTION
19	H0120200366	LOWER SPRAYER
20	H0120200367	COVER LOWER SPRAYER
21	H0120801704	FILTER ASSEMBLY DW60
	Includes	FILTER COARSE
	Includes	FILTER MICRO STAINLESS
	Includes	FILTER FLAT EXTRACTABLE SS
22	791097	CLAMP HOSE 20-32MM
23	H0120200357	GASKET SUMP
24	H0120200376	HOSE DIVERTER OUTER DUCT
25	H0120200359A	MOUNT RUBBER WASH PUMP
26	H0120400205	PUMP WASH INCL HEATER

# SPRAY ARM COMPONENTS

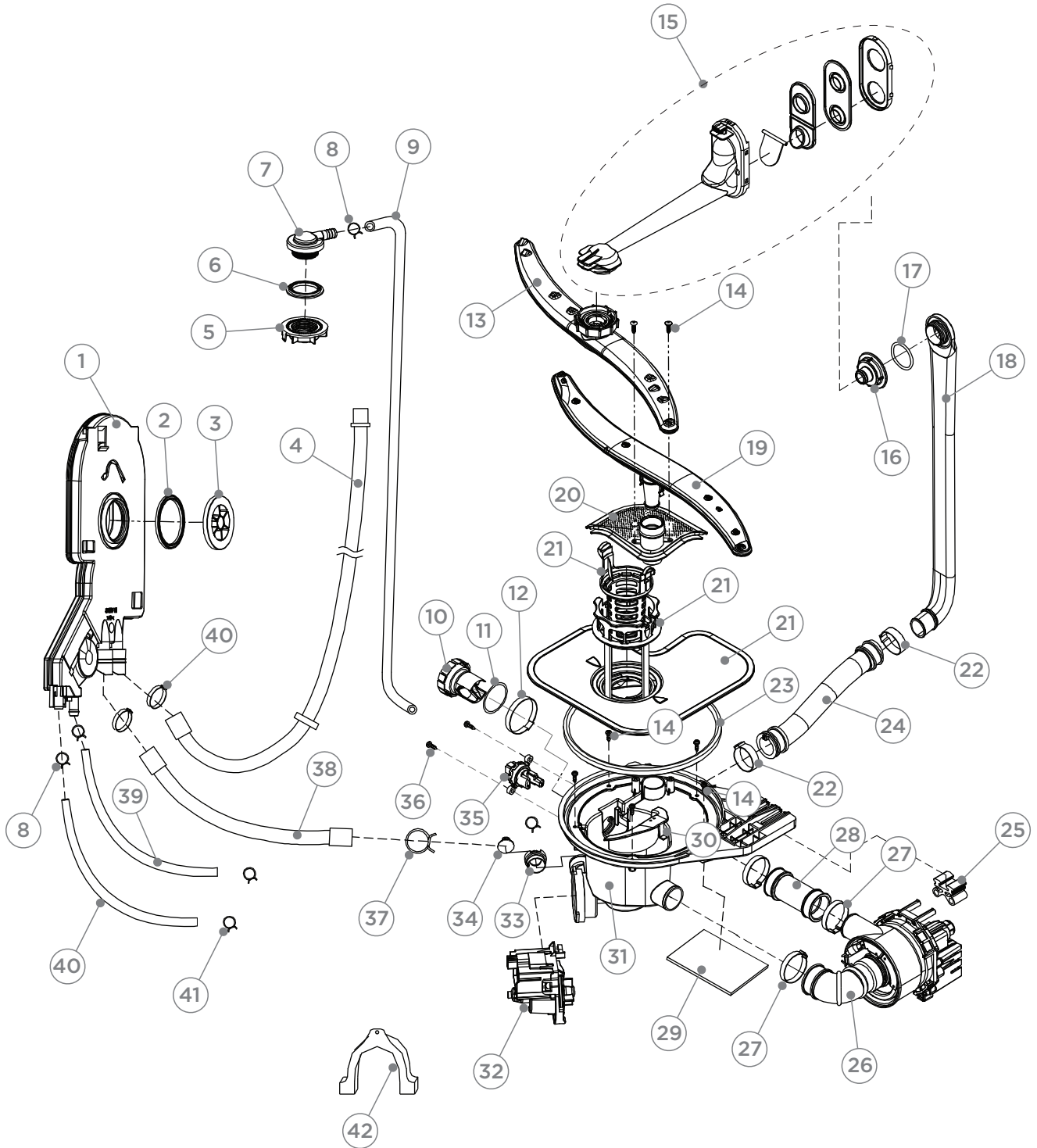

## SPRAY ARM COMPONENTS

REFERENCE	PART NUMBER	PART DESCRIPTION
27	H0120105775	CLAMP HOSE 32-50MM
28	H0120200358	PIPE DIVERTER MOTOR PUMP
29	H0030508588J	FIRE BLANKET
30	H0120200378	SCREEN SUMP OUTLET
31	H0120802652B	SUMP ASSY
32	H0120400050C	DRAIN PUMP
33	H0120200374	FRAME NON RETURN VALVE
34	H0120200373	FLAP NON RETURN VALVE
35	H0120400076	SENSOR TEMP/TURBIDITY (EMZ)
36	H012G801050	SCREW ST3.9 13
37	H0120600024	CLAMP DRAIN HOSE
38	H0120201662	HOSE DRAIN SHORT
39	H0120301100H	HOSE
40	H0120301100J	HOSE
41	H0120600027	HOSE CLAMP
42	420667P	U-SUPPORT FOR DRAIN HOSE

# BASE & FLOOD COMPONENTS

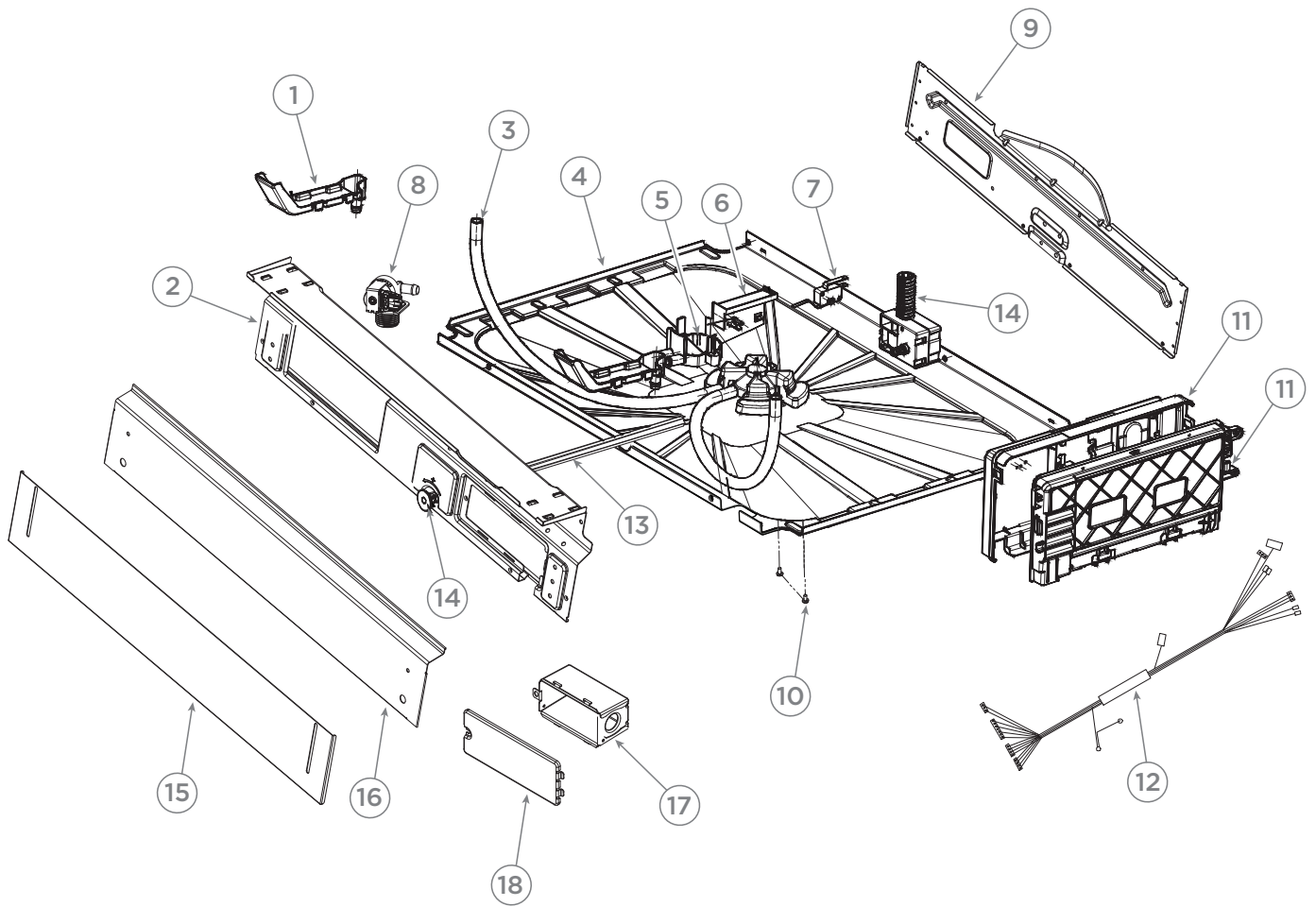

## BASE & FLOOD COMPONENTS

REFERENCE	PART NUMBER	PART DESCRIPTION
1	H0120802597	PLATE PLASTIC OVERFLOW
2	H0120102027	PANEL LOWER FRONT
3	H0120200635	HOSE OVERFLOW PLATE
4	H0120100239B	TRAY BOTTOM BASE
5	H0120505219A	FLOAT
6	H0120202056C	FLOAT SUPPORT
7	H012G6050040A	MICRO SWITCH FLOAT SWITCH
8	H0120400055F	VALVE INLET
9	H120102029	BRACKET LOWER REAR
10	H012G8010123	BOLT
11	H0120803613A	PCB MAINBOARD WITH BOX & COVER
12	H0120400215F	HARNESS CONTROL CABLE BOTTOM
13	H0120201844	LEVER ADJUSTING
14	H0120803289	KIT BACK FOOT
	Includes	BACK FOOT ASSY X 1
	Includes	ADJUSTER HEAD X 1
15	H0120102031A	BRACKET KICKSTRIP RIGHT
16	H0120102030A	BRACKET KICKSTRIP LEFT
17	H120102036	JUNCTION BOX
18	H120102037	COVER JUNCTION BOX

# DOOR COMPONENTS

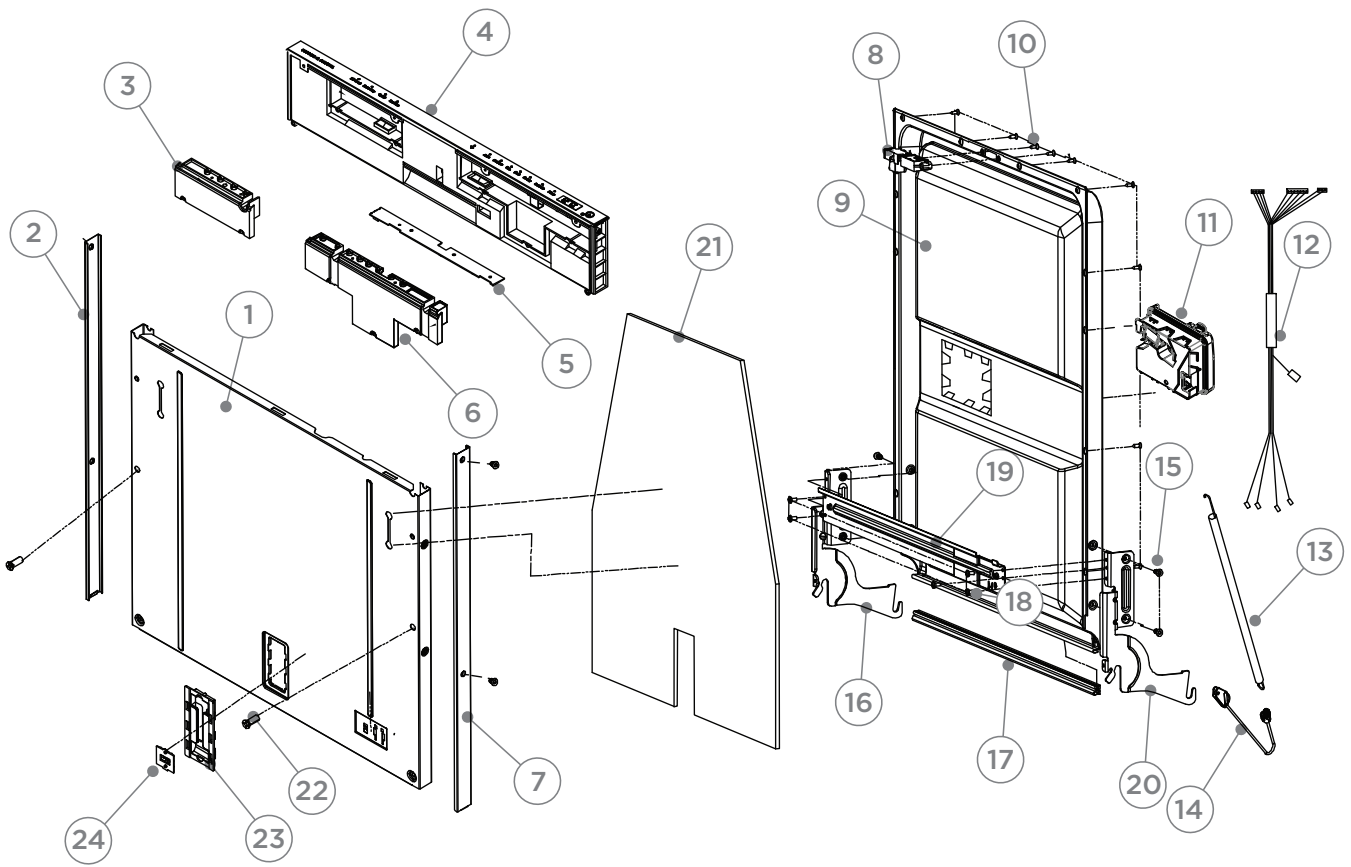

## DOOR COMPONENTS

REFERENCE	PART NUMBER	PART DESCRIPTION
1	H0120100425A	PANEL DOOR INTEGRATED GALV
2	H0120803973	KIT SS SIDE STRIP LEFT
	Includes	SS SIDE STRIP LEFT X 1
	Includes H0077050051	SCREW X 2
3	H0120201468	BOX DISPLAY BOARD LEFT
4	H0121800113A	CONTROL PANEL
5	H0121800104E	UI DISPLAY PCB KIT
6	H0120201469	BOX DISPLAY BOARD RIGHT
7	H0120803974	KIT SS SIDE STRIP RIGHT
	Includes	SS SIDE STRIP X 1
	Includes H0077050051	SCREW X 2
8	H0120801599B	DOOR SWITCH UNIT
9	H0120805709	INNER DOOR
	Includes	GASKET INNER DOOR
10	H0120600352	FIXING SCREW
11	H120400355	DISPENSER DETERGENT
12	H0120400214E	HARNESS CNTRL CABLE CNTRL PNL
13	H0120101283	SPRING FOR FS
14	H0120804662B	ROPE CONNECTING SPRING
15	H0120600023	SCREW M5 10 SS
16	H0120801670D	HINGE ASSY LEFT
17	H0120300368	GASKET INNER DOOR
18	H0020600179	SCREW (M4×10)
19	H0120100369A	PANEL HINGE LOWER DOOR
20	H0120801671D	HINGE ASSY RIGHT
21	H0120301006	DOOR INSULATION
22	H0120200437	SLEEVE DOOR FIXING
23	H0120200434	BASE DOOR ADJUSTMENT
24	H0120200435	SLIDER ADJUSTER DOOR
NI	H0120806576	KIT MOUNTING BRACKETS INSTL
NI	591919	QUICK START DW24U2 USCA
NI	591955	BOOK INSTALL DW24U US CA
NI	591917	USER GUIDE DW24U USCA

**FISHERPAYKEL.COM**

© Fisher & Paykel Appliances Ltd 2019. All rights reserved.

The product specifications in this document apply to the specific products and models described at the date of issue. Under our policy of continuous product improvement, these specifications may change at any time. You should therefore check with your Dealer to ensure this document correctly describes the product currently available.

**US CA**

**PRODUCT CODE: 81871-A 09.19**