



## 5 Burner Gas Griddle

### OWNER'S MANUAL ASSEMBLY AND OPERATING INSTRUCTIONS

**SAVE THIS MANUAL FOR FUTURE REFERENCE**

## Model GAS2540AS

**NOTICE TO INSTALLER:**  
LEAVE THESE INSTRUCTIONS WITH  
THE GRIDDLE OWNER FOR FUTURE  
REFERENCE.

### **⚠ WARNING**

HAZARDOUS EXPLOSION MAY RESULT IF THESE  
WARNINGS AND INSTRUCTIONS ARE IGNORED. READ AND  
FOLLOW ALL WARNINGS AND INSTRUCTIONS IN THIS  
MANUAL TO AVOID PERSONAL INJURY, INCLUDING DEATH  
OR PROPERTY DAMAGE.

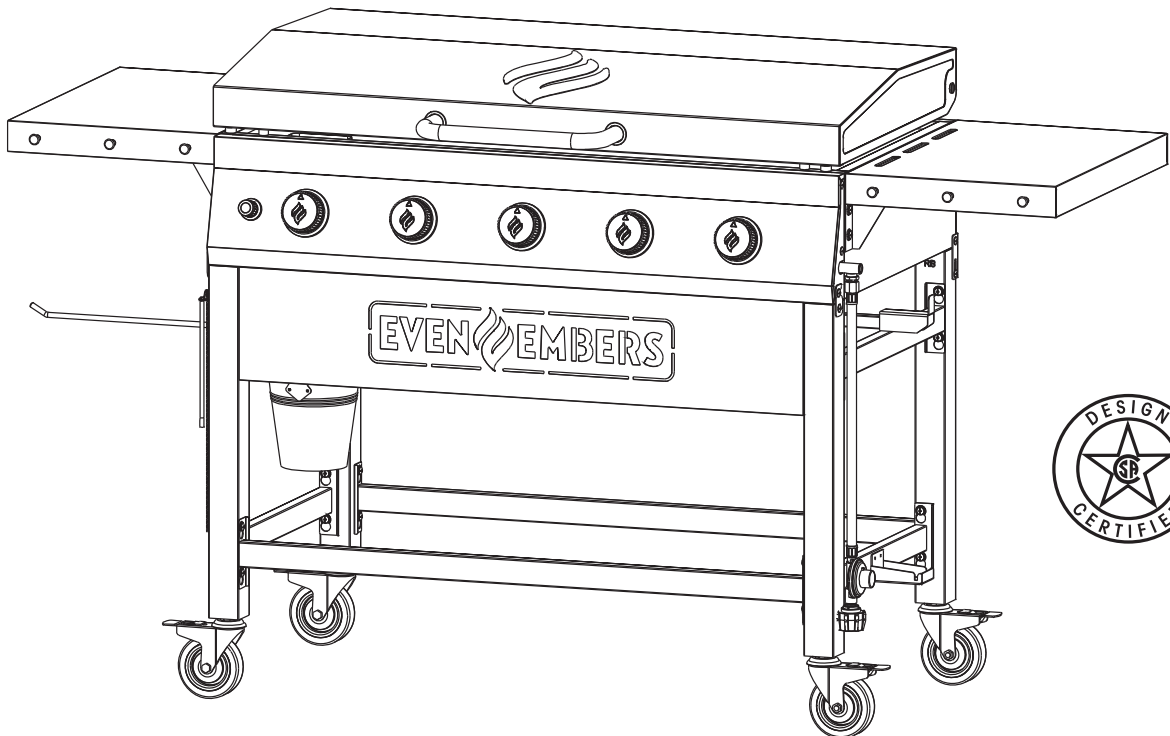

# **IMPORTANT SAFETY WARNINGS**

WE WANT YOU TO ASSEMBLE AND USE YOUR Griddle AS SAFELY AS POSSIBLE. THE PURPOSE OF THIS SAFETY ALERT SYMBOL  IS TO ATTRACT YOUR ATTENTION TO POSSIBLE HAZARDS AS YOU ASSEMBLE AND USE YOUR Griddle.

WHEN YOU SEE THE SAFETY ALERT SYMBOL  PAY CLOSE ATTENTION TO THE INFORMATION WHICH FOLLOWS!

 **READ ALL SAFETY WARNINGS AND INSTRUCTIONS CAREFULLY BEFORE ASSEMBLING AND OPERATING YOUR Griddle.**

## **DANGER**

IF YOU SMELL GAS:

1. Shut off gas to the appliance.
2. Extinguish any open flame.
3. Open lid.
4. If odor continues, keep away from the appliance and immediately call your gas supplier or your fire department.

## **WARNING**

1. Do not store or use gasoline or other flammable liquids or vapors in the vicinity of this or any other appliance.
2. An LP cylinder not connected for use shall not be stored in the vicinity of this or any other appliance.

## **DANGER**



- a) Do not store a spare LP cylinder under or near this appliance.
- b) Never fill the cylinder beyond 80% full.
- c) If the information in (a) and (b) is not followed exactly, a fire causing death or serious injury may occur.

# TABLE OF CONTENTS:

General Warnings . . . . .	3-4
LP Gas Cylinder (Tank) Specifications and Installation . . . . .	4-6
Hose & Regulator Specifications and Installation . . . . .	6-7
Leak Testing . . . . .	7-8
Pre-start Check List . . . . .	9
Lighting Instructions . . . . .	9-10
Operating the Griddle . . . . .	10-11
Proper Care and Maintenance . . . . .	11-12
Transporting and Storage . . . . .	13
Trouble Shooting . . . . .	14-15
Griddle Cooking Tips . . . . .	15
Assembly Instructions . . . . .	16-23
Warranty Information . . . . .	Back Cover

 **DANGER:** Indicates an imminently hazardous situation which, if not avoided, will result in death or serious injury.

 **WARNING:** Be alert to the possibility of serious bodily injury if the instructions are not followed. Be sure to read and carefully follow all of the messages.

 **CAUTION:** Indicates a potentially hazardous situation which, if not avoided, may result in minor or moderate injury.

## CALIFORNIA PROPOSITION 65 WARNING

 **WARNING:** This product can expose you to chemicals, including carbon monoxide, which are known to the State of California to cause birth defects or other reproductive harm.

*For more information go to [www.P65Warnings.ca.gov](http://www.P65Warnings.ca.gov)*

 **WARNING: CONTAINS LEAD. MAY BE HARMFUL IF EATEN OR CHEWED. COMPLIES WITH FEDERAL STANDARDS. KEEP OUT OF REACH OF CHILDREN.**

# GENERAL WARNINGS:

## ⚠ WARNING

- Leak test all connections before first use, even if griddle was purchased fully assembled and after each tank refill. Check the propane tank rubber seal for damage.
- Always check the unit and propane tank prior to each use as indicated in the “Checking for Leaks” & “Pre-Start Check List” sections of this manual.
- Never use natural gas in a unit designed for liquid propane gas.
- Flavoring chips must be contained in a metal smoking box to contain ash and prevent fires.
- Ensure flames come out of all burner ports at each use. Spiders and insects like to build nests in burner tubes. Blocked burner tubes can prevent gas flow to the burners and could result in a burner tube fire or fire behind the control panel.
- Never check for leaks using a match or open flame.
- Never use or store gasoline, lighter fluid, paint thinner, or other flammable vapors and liquids or combustible materials in or near your griddle.
- DO NOT block ventilation areas in sides, back or cart compartment of griddle.
- Never place more than 10 pounds on the side tables. DO NOT lean on the side tables. DO NOT lift griddle using side tables.
- Keep children and pets away from hot griddle. DO NOT allow children to use or play near this griddle.
- DO NOT leave the griddle unattended while ON or in use.
- DO NOT allow the gas hose to come in contact with hot surfaces. Redirect the gas hose if necessary.
- DO NOT allow grease or hot drippings to fall on hose and regulator assembly. If this occurs, turn gas supply OFF at once. Empty grease tray/cup and clean the hose and regulator assembly and inspect for damage before use.
- Never cook on the griddle without the grease cup/tray in position.
- Adding a large amount of cold or frozen food (or food with significant water content) to a hot griddle may cause griddle to warp.
- A slight warp may develop during heating and cooling of the griddle but should not affect the performance.
- Keep any electrical supply cords away from water or heated surfaces.
- DO NOT use water on a grease fire. Closing the lid to extinguish a grease fire is not possible. Use type BC dry chemical fire extinguisher or smother with dirt, sand or baking soda.
- DO NOT use while under the influence of drugs or alcohol.
- FOR OUTDOOR USE ONLY. DO NOT operate indoors or in an enclosed area such as a building, garage, shed or breezeway.
- Apartment dwellers: Check with management and follow the requirements and fire codes for using an LP gas griddle in your apartment complex.
- Maintain a minimum clearance of 36 inches (91 cm) between back and all sides of griddle, deck railings, walls or other combustible material. Not adhering to these clearances may prevent proper ventilation and can increase the risk of a fire and/or property damage, which could also result in personal injury. DO NOT use griddle under overhead combustible construction.
- DO NOT use or install this griddle in or on a recreational vehicle and/or boat.
- DO NOT build this model griddle in any built-in or slide in construction.
- If a bristle brush is used to clean any of the cooking surfaces, ensure no loose bristles remain on the cooking surfaces prior to grilling as loose bristles may attach to food.
- DO NOT store items in cart that can catch fire or damage your griddle (such as swimming pool supplies/chemicals, table cloth, wood chips).

- Griddle is hot when in use. To avoid burns:
  - DO NOT attempt to move the griddle.
  - Block the wheels so the unit does not accidentally move.
  - Wear protective gloves or oven mitts.
  - DO NOT touch any hot griddle surfaces.
  - DO NOT wear loose clothing or allow hair to come in contact with griddle.
- Not for commercial use. DO NOT use this griddle for anything other than its intended purpose.

**⚠ USE CAUTION AND COMMON SENSE WHEN OPERATING YOUR GAS GRIDDLE.**

**FAILURE TO ADHERE TO THE SAFETY WARNINGS AND GUIDELINES IN THIS MANUAL  
COULD RESULT IN SEVERE BODILY INJURY OR PROPERTY DAMAGE.  
SAVE THIS MANUAL FOR FUTURE REFERENCE.**

## **LP GAS CYLINDER (TANK) SPECIFICATIONS AND INSTALLATION:**

### **⚠ WARNING**

- ONLY connect this griddle to a Type 1 cylinder valve. The Type 1 valve can be identified with the large external threads on the valve outlet.
- DO NOT connect to a propane cylinder exceeding a 20 lb. (9.1 kg) capacity.
- DO NOT connect to a cylinder that uses any other type of valve connection device.
- Inspect the propane tank valve rubber seal for cracks, wear or deterioration prior to use. A damaged rubber seal can cause a gas leak, possibly resulting in an explosion, fire or severe bodily harm.
- Turn off the cylinder valve when your griddle is not in use.
- Handle the tank with care.
- Always secure the cylinder in an upright position.
- Never connect an unregulated LP gas cylinder to your griddle.
- DO NOT expose LP gas cylinders to excessive heat or ignition sources.
- DO NOT store a spare LP gas cylinder under or near your griddle.
- Allow only qualified LP gas dealers to fill or repair your LP gas cylinder.
- DO NOT allow the cylinder to be filled beyond 80% capacity.
- Read and follow all warnings and instructions that are on the cylinder and that accompany this product.

### **⚠ DANGER**

- DO NOT store a spare LP gas cylinder (full or empty) under or near your griddle. This could cause excess pressure to be expelled through the vapor relief valve resulting in fire, explosion, or severe personal injury, including death.
- Propane gas is heavier than air and will collect in low areas. Proper ventilation is extremely important. Keep the ventilation opening(s) of the LP gas cylinder enclosure free and clear from obstructions and debris.
- DO NOT insert any foreign objects into the cylinder valve outlet as this could damage the rubber seal. Do not use propane tank with a damaged rubber seal. A damaged rubber seal can cause a gas leak, possibly resulting in explosion, fire, severe bodily harm, or death. Inspect rubber seal for cracks, wear or deterioration prior to use.
- Always keep cylinder (tank) in upright position during use, transit or storage.

## LP GAS CYLINDER (TANK) SPECIFICATIONS:

### LP gas cylinder (not supplied with this griddle)

The LP (Liquid Propane) gas cylinder specifically designed to be used with this griddle must be 12" (30.5 cm) diameter x 18" (45.7 cm) tall and have a 20 lb. (9.1 kg) capacity incorporating a Type 1 cylinder valve and an over-filling protection device (OPD).

This griddle is designed to fit Worthington, Manchester or SMPC brand 20 lb. (9.1 kg) cylinders. Other brand DOT cylinders may fit this griddle if the cylinder has similar dimensions of the top and bottom rings.

The installation of this appliance must be in accordance with:

All applicable local codes, or in the absence of local codes, either:

- National Fuel Gas Code ANSI Z223.1 NFPA 54
- Natural Gas and Propane Installation Code: CAN/CGA B149.1
- Natural Gas Installation Code: CAN/CGA B149.1 (Canada)
- Propane Installation Code: CAN/CGA B149.2 (Canada)

To check your local codes, see your local LP gas dealer or natural gas company. This griddle was not intended to be connected to a natural gas supply line. If an external electrical source is utilized, it must be electrically grounded in accordance with local codes, or in the absence of local codes, with the National Electrical Code, ANSI/NFPA 70, or the Canadian Electrical Code, CSA 22.1.

When purchasing or exchanging a cylinder for your gas griddle, it must be constructed and marked in accordance with the specifications for LP gas cylinders of the U.S. Department of Transportation (DOT) or the National Standard of Canada, CAN/CSA-B339 Cylinders, Spheres and Tubes for Transportation of Dangerous Goods; and Commission, as applicable; and provided with a listed over-filling prevention device (OPD), and provided with a cylinder connection device compatible with the connection for outdoor cooking appliances.

The cylinder must also be equipped with:

- A shut-off valve terminating in a Type 1 gas cylinder valve outlet.
- A Type 1 valve that prevents gas flow until a positive seal is obtained.
- An arrangement for vapor withdrawal.
- A collar to protect the cylinder shut-off valve.
- A safety relief device having direct communication with the vapor space of the cylinder.
- A listed over-filling prevention device (OPD).

## FILLING THE LP GAS CYLINDER (TANK):

### **WARNING**

- **Allow only qualified licensed LP gas dealers to properly fill or repair your LP gas cylinder.**
- **New tanks should be purged prior to filling; inform LP gas dealer if you are using a new tank.**
- **DO NOT allow the cylinder to be filled beyond 80% capacity. Over-filled tanks can create a dangerous condition. Over-filled tanks can build-up pressure and cause the relief valve to expel propane gas vapors. The vapor is combustible and if it comes in contact with a spark source or flame an explosion causing severe burns, bodily harm, or death could occur.**
- **Always use a protective cylinder cap when griddle is not connected to cylinder.**
- **If you exchange a cylinder with a qualified exchange program, the new cylinder must have a Type 1 valve and an over-filling prevention device (OPD).**
- **Inspect the propane tank valve rubber seal for cracks, wear or deterioration prior to use. A damaged rubber seal can cause a gas leak, possibly resulting in an explosion, fire or severe bodily harm.**

## LP GAS CYLINDER (TANK) RUBBER SEAL INSPECTION:

- Inspect the propane tank valve rubber seal for cracks, wear or deterioration prior to use. A damaged rubber seal can cause a gas leak, possibly resulting in an explosion, fire or severe bodily harm.
- Inspection should be done each time the propane tank is connected to the griddle, has been refilled, exchanged or has not been used for more than 60 days.
- Do not use a propane tank with a damaged rubber seal. Exchange the tank or have the rubber seal replaced at a qualified propane filling station.

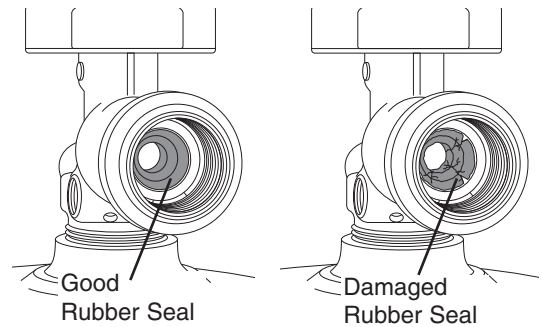

## INSTALLING THE LP GAS CYLINDER (TANK) ONTO THE GRIDDLE:

1. Check that the cylinder valve is closed by turning the knob clockwise. Inspect cylinder valve rubber seal for cracks or deterioration. Do not use propane tank with damaged seal as a gas leak may occur.
2. Support the cylinder on the upper and lower tank holders on right side of cart.
3. Orient the cylinder such that the valve opening faces the front of the griddle and the hose is not kinked or damaged.

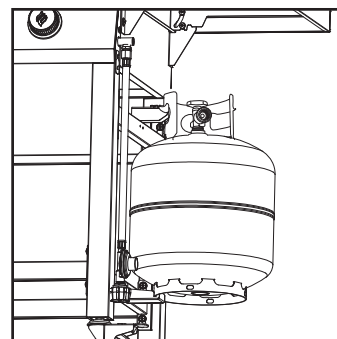
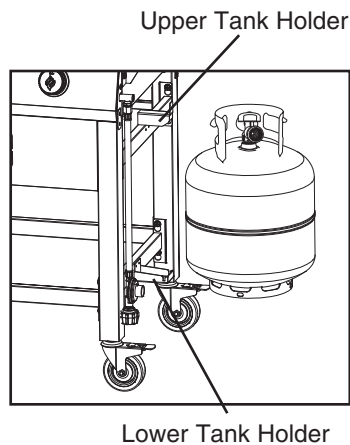

## HOSE & REGULATOR SPECIFICATIONS AND INSTALLATION:

### ⚠ WARNING

- DO NOT attempt to connect griddle, as purchased for LP (propane) gas, to any other fuel supply source such as a natural gas line. For dual fuel griddles that can be converted to natural gas, a Even Embers conversion kit must be purchased and installed for use with natural gas.
- DO NOT use any other pressure regulator/hose assembly other than the one supplied with your griddle. Replacement pressure regulator/hose assembly must be part No 2540-155-7600-0, which can be obtained by contacting customer service at 1-855-735-9922.
- DO NOT attempt to adjust or repair a regulator. The regulator is designed to operate at a maximum output pressure of 11 inches of water column (2.74 kPa).
- Ensure the tank valve is **CLOSED** prior to connecting the LP gas cylinder to your griddle. Turn the valve knob clockwise to properly close the valve. Read and follow all instructions and warnings on the supply hose safety tags. Read and follow all warnings in this manual concerning the safe use of LP gas cylinders and the hose and regulator before connecting cylinder to griddle. Read and follow all warnings on the LP cylinder.

## HOSE AND REGULATOR:

Your griddle is equipped with a Type 1 connection device with the following features:

1. The system will not allow gas flow from the cylinder until a positive connection to the valve has been made.  
Note: The cylinder valve and all griddle burner knobs must be turned OFF before any connection is made or removed.
2. A regulator flow limiting device, when activated, restricts the flow of gas to 10 cubic feet per hour. If the flow limiting device is activated, perform Regulator Resetting Procedure.  
Note: If your griddle will not get hot enough to cook, the flow limiting device may have been activated.

## CONNECTING HOSE AND REGULATOR:

1. Inspect the propane tank valve rubber seal for cracks, wear or deterioration prior to use. A damaged rubber seal can cause a gas leak, possibly resulting in an explosion, fire or severe bodily harm. Do not use a propane tank with a damaged rubber seal.
2. Attach or detach regulator to the LP gas cylinder only when cylinder is at rest in tank holder.
3. Check that the cylinder valve is closed by turning the knob clockwise.
4. Check that the griddle's burner control knobs are in the "OFF" positions.
5. Visually inspect the hose assembly prior to each use for evidence of damage, excess wear, or deterioration. If found, replace the assembly before using your griddle. Only the manufacturer's supplied replacement should be used.
6. Remove the protective plastic cap from the cylinder valve.
7. Check that the hose does not contain kinks, does not contact sharp edges, and does not contact surfaces that may become hot during use.
8. Hold regulator and insert the brass nipple into the LP cylinder valve outlet. Ensure that the device is centered properly.
9. Turn the large coupling nut clockwise by hand and tighten to a full stop. Take care not to cross thread the coupling nut onto the cylinder valve. Do not use tools to tighten connection.  
Note: If you are unable to make the connection, repeat Steps 7 and 8.
10. Leak check all fittings before lighting your griddle. See section on "Leak Testing" in this manual.  
Note: To remove regulator from propane tank, turn off the tank valve and rotate the large coupling nut counter-clockwise and remove.

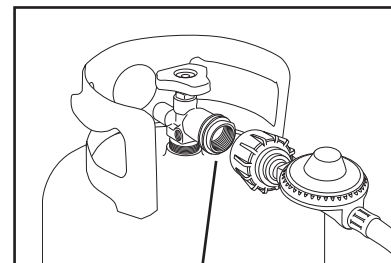

Inspect Rubber Seal (see page 6)

## REGULATOR RESETTING PROCEDURE:

If your griddle will not get hot enough to cook, the flow limiting device may have been activated.

Mini Reset:

Turn ALL burner control knobs to "OFF"; turn off the cylinder valve. Wait one minute. Slowly turn cylinder valve ON and relight griddle. If burner flame is higher and griddle heats up properly – proceed with cooking.

Full Reset:

Turn ALL burner control knobs to "OFF"; turn off the cylinder valve. Disconnect hose and regulator from cylinder. Wait two minutes, reattach hose and regulator and perform leak test.

## LEAK TESTING:

### **⚠WARNING**

- Never use your griddle without leak testing all gas connections, hoses and propane tank. Follow the section on "Leak Testing" in this manual for proper procedures.



## **⚠ DANGER**

To prevent fire or explosion hazard:

- **DO NOT** smoke or permit ignition sources in the area while conducting a leak test.
- Perform test **OUTDOORS** in a well ventilated area that is protected from the wind.
- **Never** perform a leak test with a match or open flame.
- **Never** perform a leak test while the griddle is in use or while griddle is still hot.

### **WHEN TO PERFORM A LEAK TEST:**

- After assembling your griddle and before lighting for the first time, even if purchased fully assembled.
- Every time the LP gas cylinder is refilled, exchanged or if any of the gas components are disconnected or replaced.
- Any time your griddle has been moved.
- At least once per year or if your griddle has not been used for more than 60 days.

### **CHECKING FOR LEAKS:**

**⚠ CAUTION:** Strong odors, colds, sinus congestion, etc. may prevent the detection of propane by smell. Use caution and common sense when testing for leaks.

Note: The leak test must be performed in an area that has adequate lighting in order to see if bubbles are developing and not in a windy or noisy area so larger leaks can be detected by smell or sound.

1. Create a mixture of 50% water and 50% liquid dishwashing soap.
2. Open the lid.
3. Ensure all control knobs are set to the "OFF" position.
4. Turn on the gas at the cylinder valve. Turn the cylinder valve knob counter-clockwise to full open. If you hear a rushing sound or smell gas, turn the gas off. Tighten any leaking connections. If leak is detected at connection nut and tightening does not stop leak, reinspect propane tank rubber seal.
5. Apply the soapy water mixture to the following:
  - (A) Supply tank (cylinder) weld.
  - (B) Connection nut to tank valve.
  - (C) Back side of connection nut to brass nipple.
  - (D) Brass nipple connection into regulator.
  - (E) Regulator connections to gas supply hoses.
  - (F) Hose connection to gas manifold.
  - (G) The full length of gas supply hose.
  - (H) Tank valve to cylinder.
6. Check each place listed (A–H) for growing bubbles, which indicates a leak. Large leaks may not be detected by bubbles but should produce a rushing sound or gas smell.
7. Turn off gas supply at cylinder valve.
8. Turn on control knobs to release gas pressure in hose.
9. Turn control knobs to "OFF" position.
10. Tighten any leaking connections. If leak is detected at connection nut and tightening does not stop leak, reinspect propane tank rubber seal. (see page 6)
11. Repeat soapy water test until no leaks are detected.
12. Turn off gas supply at cylinder valve until you are ready to use your griddle.
13. Wash off soapy residue with cold water and towel dry.
14. Wait 5 minutes to allow all gas to evacuate the area before lighting griddle.

**⚠ WARNING:** **DO NOT** use the griddle if leaks cannot be stopped. Contact a qualified gas appliance repair service.

**Watch For Bubbles**

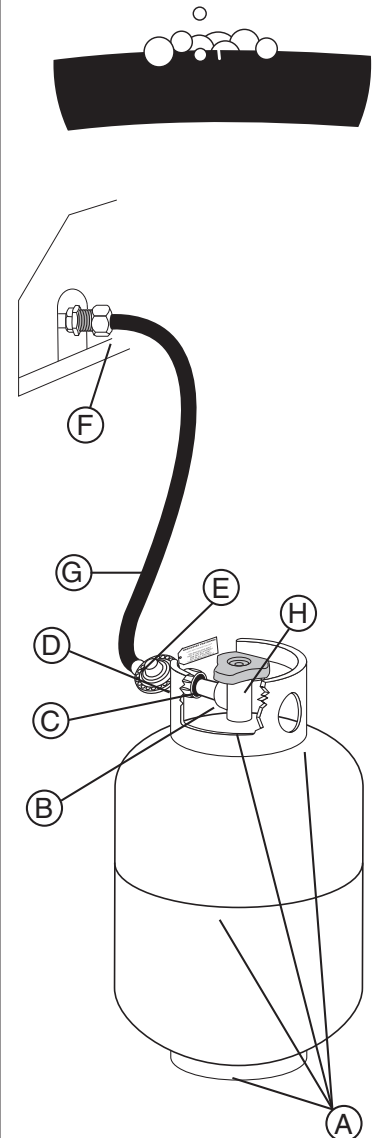

## PRE-START CHECK LIST:

### **⚠ DANGER**

Property damage, bodily harm, severe burns, and death could result from failure to follow these safety steps. These steps should be performed after the griddle has been assembled and prior to each use. **DO NOT** operate this griddle until you have read and understand **ALL** of the warnings and instructions in this manual.

- Ensure that the griddle is properly assembled.
- Inspect the gas supply hose for burns, chaffing, kinks, and proper routing before each use. If it is evident there is excessive abrasion or wear, or the hose is cut, it must be replaced prior to the griddle being used. Replace with hose and regulator Model No. 2540-155-7600-0, which can be obtained by contacting customer service at 1-855-735-9922.
- Leak check all gas connections, hose and propane tank. See section on “Leak Testing”
- Ensure that all electrical supply cords are properly grounded. Keep any electrical supply cord and the fuel supply hose away from any heated surfaces. Hose should be at least 3 inches from hot surfaces.
- Position your griddle on a non-combustible level surface in a well ventilated location, a safe distance from combustible materials, buildings and overhangs.
- Properly place the empty grease cup under the grease drain hole in the bottom of the griddle to catch grease during use.
- **DO NOT** block ventilation areas in sides, back or cart compartment of griddle.

## GAS LIGHTING INSTRUCTIONS:

### **⚠ WARNING**

Read, understand and follow all warnings and instructions contained in this manual. **DO NOT** skip any of the warnings and instructions contained in the preceding sections of this manual.

Follow the instructions exactly.

1. **Open the griddle lid before attempting to light a burner so that fumes do not accumulate inside the griddle. An explosion could occur if griddle lid is down.**
2. **Check that all burner control knobs and the cylinder valve are turned to the “OFF” position.**
3. **Turn on the fuel supply by slowly rotating the cylinder valve knob counter-clockwise to full open.**
4. **DO NOT stand with head, body, or arms over the griddle when lighting.**

### LIGHTING THE MAIN BURNERS:

1. Open lid before lighting burner.
2. Make sure all control knobs are in the “OFF” position.
3. Select burner to be lit. Push and turn control knob to “HIGH.” Push and hold the igniter for 3 - 5 seconds.
4. If ignition does NOT occur in 5 seconds, turn control knob to “OFF”; wait 5 minutes to allow gas to dissipate and repeat lighting procedure.
5. To light other burners, follow steps 3-4.
6. If burner does not ignite using the igniter, see “Match Lighting the Main Burners” section.
7. To turn off, turn each control knob clockwise until it locks in the “OFF” position. This does not turn off the gas flow from the cylinder.

Note: If burner does not light or flame is too low, See “Trouble Shooting” section of the owners manual.

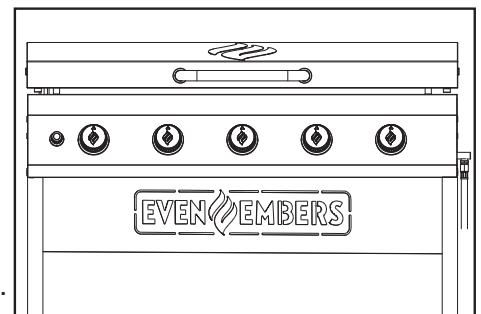

## MATCH LIGHTING THE MAIN BURNER:

1. Open lid before lighting burner.
2. Make sure all control knobs are in the “OFF” position.
3. Place a paper match in the end of the matchlighter. Strike the match and place the match as shown approximately 1/2” (1 to 2 cm) from the burner to be lit.
4. Turn the burner control knob to the “HIGH” position. The burner should light within 5 seconds.
5. If the burner does not light, turn the control knob to “OFF” and wait 5 minutes for gas to dissipate and repeat lighting procedure.
6. Once lit, light adjacent burners by following steps 3-6.
7. If the burner does not light within the first few attempts of match lighting, there is a problem with the gas supply. Turn off the gas at the burner and cylinder. DO NOT attempt to operate the griddle until the problem is found and corrected.

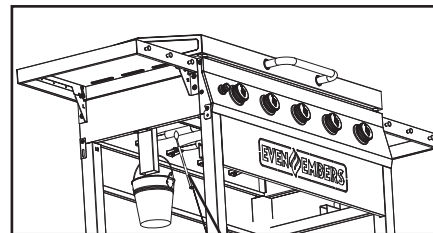

Matchlighter

Note: If burner does not light or flame is too low, See “Trouble Shooting” section of the owners manual.

## OPERATING THE GRIDDLE:

### **⚠ WARNING**

- Read and follow all warnings and instructions contained in the preceding sections of this manual.
- Flavoring chips must be contained in a metal smoking box to contain ash and prevent fires.
- DO NOT cover griddle or other components with aluminum foil, as this blocks ventilation and damage to griddle or personal injury may occur.
- DO NOT leave your griddle unattended while “ON” or in use.
- DO NOT move griddle when in use.
- DO NOT use water on a grease fire. Closing the lid to extinguish a grease fire is not possible. Use type BC dry chemical fire extinguisher or smother with dirt, sand or baking soda.
- Never cook on the griddle without the grease cup/tray in place.

## GRIDDLE SEASONING INSTRUCTIONS:

For best results, we recommend seasoning the griddle before cooking on griddle top.

- Step 1 Make sure griddle top is wiped clean of debris (refer to Cleaning Your Griddle)
- Step 2 Ignite griddle by following the lighting instructions. Turn all knobs to HIGH and wait 10 to 15 minutes until your griddle top starts to discolor.
- Step 3 Pour 3 tablespoons of oil on griddle top. Any cooking oil will work.
- Step 4 Use cooking tongs or heat resistant gloves to hold folded paper towels. Spread the cooking oil over the surface of griddle top evenly by using the folded paper towel. Be sure to cover every part of the griddle top (i.e. corners, sides, etc.).
- Step 5 Once your griddle is covered with a thin layer of cooking oil, allow griddle to heat on HIGH. Smoking will occur as the oil begins to bond with the griddle top, creating a non-stick surface.
- Step 6 When griddle top has stopped smoking and there isn't a noticeable amount of sheen, repeat steps 3-5 at least three more times.

Note: After repeating the seasoning steps, your griddle top may not appear to be completely black or even. To achieve a dark surface, start cooking on your griddle top which will help create a nicely seasoned griddle top.

Note: Your Even Embers griddle was pre-treated with vegetable oil as a protective coating. This coating may leave a discoloration on the griddle, but this will not affect the seasoning process.

## TURNING OFF THE GRIDDLE:

1. Turn off the cylinder valve.
2. Turn all burner control knobs to the “OFF” position.

Note: Turn off LP cylinder first to prevent gas from being left in the system under pressure.

### ⚠ CAUTION:

- The cylinder valve should always be in the off, or closed, position when the griddle is not in use.

To turn off the cylinder valve,  
turn knob clockwise until it stops.

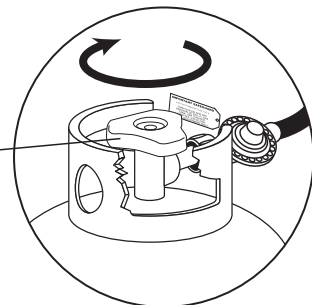

## PROPER CARE & MAINTENANCE:

### CLEANING YOUR GRIDDLE:

First Time Cleaning – your Even Embers Griddle has been pre-treated with a vegetable oil coating to prevent rust and damage during shipping. For first time use, wash the griddle with hot and soapy water. This is the ONLY time you should use soap on the griddle cooking surface. Rinse off the soap and allow it to completely dry. Proceed with the seasoning instructions (Refer to GRIDDLE SEASONING INSTRUCTIONS).

### CLEANING THE GRIDDLE COOKING SURFACE:

- Step 1 To clean griddle after each use, cool griddle top below 300 F° and scrape food debris with a spatula or a metal scraper.
- Step 2 Wipe down the griddle surface with a paper towel.
- Step 3 Working in small sections, apply a small amount of water onto first section and then scrape the water and debris toward the grease cup. Move to the next section and repeat. Note – do not use more than 3 tablespoons of water at a time. ¼ cup of table salt may be used to help remove food that is stuck to the griddle.
- Step 4 Wipe again with a paper towel and dry completely.
- Step 5 Apply a thin coating of cooking oil to maintain seasoning to protect the griddle top from rust.

⚠ CAUTION: NEVER APPLY COLD WATER ACROSS THE WHOLE COOKING SURFACE OF A HOT GRIDDLE AT ONCE. This may cause warping.

⚠ CAUTION: DO NOT USE SOAP ON THE GRIDDLE COOKING SURFACE. This will damage the griddle's seasoning.

### FAQ'S:

What types of cooking oils can I use to season my griddle?

- We recommend the following oils to season your griddle – vegetable oil, canola oil, coconut oil, flax seed oil, olive oil, or sesame oil.

Can I use dish detergent to clean my griddle?

- Grease cutting dish soap will erase the seasoning on the griddle and should not be used after the griddle has been seasoned. For tough spots, use table salt and hot water and always coat with a thin layer of oil once you are finished cleaning.

Why does my griddle surface look dull and dry instead of shiny and black?

- Seasoning a griddle is a continuous process. The more often you use your griddle, the more shiny, black, and non-stick it will become.

What if my griddle starts to rust?

- If rust appears on the griddle surface, rub it off with steel wool or low grit sandpaper and re-season the surface. Take care to always completely dry your griddle before storing and make sure you have applied a thin coating of cooking oil to every part of the griddle.
- CUSTOMERS IN HUMID OR COASTAL CLIMATES MAY REQUIRE MORE FREQUENT SEASONINGS AND THE USE OF HEAVIER COOKING OILS TO PREVENT RUST/CORROSION.

## BURNER CLEANING AND MAINTENANCE:

- Keep the appliance free and clear of combustible materials, gasoline and other flammable vapors and liquids.
- Keep the ventilation openings of the cylinder enclosure free and clear of debris.
- Visually check burner flames for proper operation (see pictorial in “Burner Assembly/Maintenance” under Proper Care and Maintenance). Spiders or other insects can nest in the burner causing gas blockage.
- For safe grilling and peak performance of your griddle, perform these checks at least twice per year or after extended periods of storage.
- Be sure to tighten up all hardware (nuts, screws, etc.) at least twice per year.

**CAUTION:** Some parts may contain sharp edges. Wear protective gloves if necessary.

- Remove the cooking griddle and burners from inside your griddle. Use a brush with hot water and detergent to remove excess residue. NEVER use a commercial oven cleaner. Rinse completely with water. Towel dry and replace all components as described in the assembly instructions.

## BURNER ASSEMBLY/MAINTENANCE:

- Although your burners are constructed of stainless steel, they may corrode as a result of the extreme heat and acids from cooking foods. Regularly inspect the burners for cracks, abnormal holes, and other signs of corrosion damage. If found, replace the burner.

- DO NOT block ventilation areas in sides, back or cart compartment of griddle. Burner tubes can become blocked by spiders and other insects building their nests. Blocked burner tubes can prevent gas flow to the burners and could result in a burner tube fire or fire beneath the griddle. To clean the Burner Assembly follow these instructions to clean and/or replace parts of burner assembly or if you have trouble igniting the griddle.

1. Turn gas off at control knobs and LP cylinder tank valve.
2. Remove cooking griddle.
3. Remove cotter pin from each burner post.
4. Carefully lift each burner up and away from valve openings.
5. Use a narrow bottle brush or a stiff wire bent into a small hook to run through each burner tube or use compressed air to blow into burner tube and out the flame ports. Check each port to make sure air comes out each hole.

**CAUTION:** Wear eye protection when using compressed air.

6. Use a wire brush to clean the entire outer surface of burner to remove food residue and dirt.
7. Check burner for damage, if any cracks or holes are found replace burner.
8. Install burner in griddle, orient burners CORRECTLY.

**IMPORTANT:** Burner opening must slide over valve nozzle.

9. Replace cotter pins on each burner post.

Note: Follow the “Gas Leak Testing” section of this manual. Relight burners to verify proper operation.

10. Replace griddle and lid assembly.

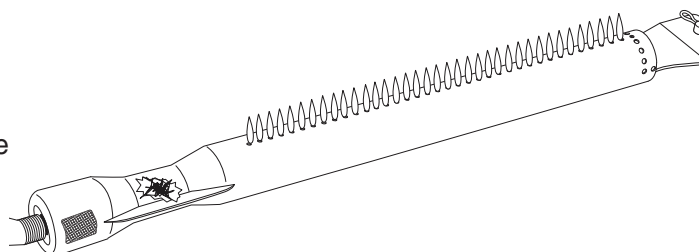
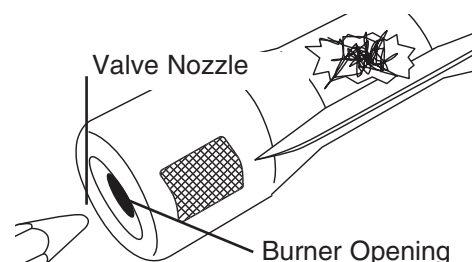
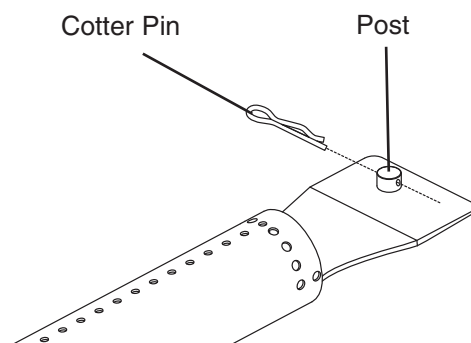
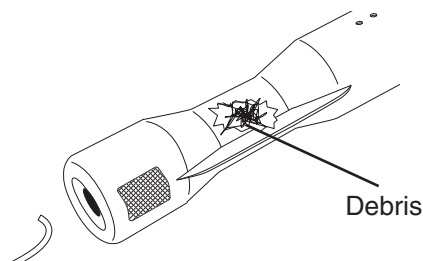

### PROPER VALVE TO BURNER ALIGNMENT

Note: Normal flame height is 1" to 2"

## TRANSPORTING AND STORAGE:

### **WARNING**

- Never move a griddle when hot or in use.
- Make sure that cylinder valve is closed and burner knobs are in the off position.
- DO NOT store a spare LP gas cylinder (filled or empty) under or near the griddle.
- Never store flammable liquids or spray canisters under or near the griddle.
- If the outdoor cooking gas appliance is not in use, the gas must be turned off at the LP gas supply cylinder.
- Storage of an outdoor cooking gas appliance indoors is permissible only if the cylinder is disconnected and removed from the outdoor cooking gas appliance.
- Cylinders must not be stored in a building or enclosure, including garages and sheds.
- Cylinders must be kept out of reach of children.

### **BEFORE STORING YOUR GRIDDLE:**

- Ensure that the cylinder valve is fully closed.
- Clean all surfaces. Lightly coat the burners with cooking oil to prevent excess rusting.
- If storing the griddle indoors, disconnect the LP tank and leave the LP tank OUTDOORS.
- Place dust cap on cylinder valve outlet whenever the cylinder is not in use. Only install the type of dust cap on the cylinder valve outlet that is provided with the cylinder valve. Other types of caps or plugs may result in leakage of propane.
- Check and clean burner prior to use after storing, at the beginning of grilling season or after a period of not being used. Spiders and insects like to build nests in burner tubes (especially during colder months). Blocked burner tubes can prevent gas flow to the burners and could result in a burner tube fire or fire beneath the griddle. See “Burner Assembly/Maintenance” under Proper Care and Maintenance.
- In order to extend and maintain the life and condition of the griddle, we recommend that the unit be covered when stored outside.

# TROUBLE SHOOTING:

<b>Problem</b>	<b>Possible Cause</b>	<b>Prevention/Cure</b>
<b>Burner will not light</b>	LP gas tank valve is closed	Make sure regulator is securely attached to the LP gas tank, turn LP gas tank valve to "OPEN"
	LP gas tank is low or empty	Check if LP gas tank is empty. If empty, replace or refill.
	LP gas leak	1. Turn LP gas tank valve to "CLOSED" 2. Wait 5 minutes for gas to clear 3. Follow "Leak Testing" in the owner's manual
	Coupling nut and regulator not fully connected	See section on "Connecting Hose and Regulator"
	Obstruction of gas flow	1. Clean burner assembly 2. Check for bent or kinked hose
	Burner may not be properly seated	Reseat burner and valve. Refer to "Burner Assembly/Maintenance" instructions
	Spider webs or insect nest in venturi	Clean venturi and burner assembly
	Burner ports clogged or blocked	Clean burner ports
	Battery needs to be changed	Replace the battery (follow assembly step for inserting battery)
	Wires or electrode covered with cooking residue	Clean wire and/or electrode with rubbing alcohol
	Electrode and burners are wet	Wipe dry with cloth
	Electrode cracked or broken - sparks at crack	Replace electrode
	Wire loose or disconnected	Reconnect wire or replace electrode/wire assembly
	Wire is shorting (sparking) between ignitor and electrode	Replace ignitor wire/electrode assembly
Bad ignitor	Replace ignitor	
<b>Griddle does not get hot enough</b>	Out of gas	Replace or refill LP gas tank
	Flow limiting device may have been activated	1. Mini Reset: a. Turn control knobs and LP gas tank valve to "OFF" b. Wait one minute and relight griddle per "Lighting Instructions" 2. If flames are still too low, perform a Full Reset Full Reset: a. Turn control knobs and LP gas tank valve to "OFF" b. Disconnect regulator from propane tank c. Inspect LP cylinder rubber seal d. Wait 1 minute e. Reconnect regulator and perform "Leak Testing" on all connections. f. Light griddle per "Lighting Instructions"
<b>Irregular flame pattern. Flame does not run full length of burner</b>	Burner ports are clogged or blocked	Clean burner ports
	Air shutter on burner needs adjustment	See section on "Burner Adjustment"
<b>Flame is yellow or orange</b>	New burner may have residual manufacturing oils	Burn griddle for 15 minutes on "HIGH" with the lid closed
	Spider webs or insect nest in venturi	Clean venturi and burner assembly
	Food residue, grease, etc.	Clean burner assembly
	Poor alignment of valve to burner venturi	Make sure burner venturi is properly engaged with valve
	Air shutter on burner needs adjustment	See section on "Burner Adjustment"

<b>Problem</b>	<b>Possible Cause</b>	<b>Prevention/Cure</b>
<b>Flame blows out</b>	High or gusting winds	Do not use griddle in high winds
	Low on LP gas	Replace or refill LP gas tank
	Burner holes may be obstructed	Refer to "Burner Assembly/Maintenance" instructions
	Flow limiting device tripped	Refer to "Regulator Resetting Procedure"
<b>Flare-up</b>	Grease buildup	Clean all parts per "Proper Care and Maintenance" instructions
	Excess fat in meat	Trim fat from meat before grilling
	Excessive cooking temperature	Adjust (lower) cooking temperature
<b>Grease fire</b>	Grease trapped by food buildup around burner system	<ol style="list-style-type: none"> <li>1. Turn control knobs and LP gas tank valve to "OFF"</li> <li>2. Leave lid in open or closed position and let fire burn out. Use BC type fire extinguisher or baking soda, sand or dirt to smother fire, if necessary.</li> <li>3. After griddle cools, remove and clean all parts per "Proper Care and Maintenance" instructions</li> </ol>
<b>Flashback (fire in burner tubes) / knobs melting</b>	Burner and/or burner tubes are blocked	Clean burners and/or burner assembly
<b>Inside of lid is peeling (like paint peeling)</b>	Baked on grease buildup has turned into carbon and is flaking off	Clean thoroughly per "Proper Care and Maintenance" instructions

## **GRIDDLE COOKING TIPS:**

### **CLEANLINESS:**

- Always wash hands thoroughly with soap and hot water prior to handling food and after handling raw meat, uncooked poultry or seafood.
- When using a platter to carry raw meat, uncooked poultry or seafood to the griddle, make sure to wash the platter thoroughly with soap and hot water before placing cooked foods back on the platter or use different platters for raw and cooked foods.
- Never use the same utensils when handling raw meat, uncooked poultry or seafood unless you wash the utensils thoroughly with soap and hot water.
- Never re-use marinade from raw meat or uncooked poultry on foods that have been cooked and are ready to be served.

### **GRILLING TO PROPER TEMPERATURE:**

- Use a meat thermometer to be sure food has reached a safe internal temperature.
- The USDA recommends the minimum temperature be reached for the following food items:

<b>Chops</b> .....	<b>145° F (62.8° C)</b>	<b>Roasts</b> .....	<b>145° F (62.8° C)</b>
<b>Ground Meat</b> .....	<b>160° F (71° C)</b>	<b>Seafood</b> .....	<b>145° F (62.8° C)</b>
<b>Pork</b> .....	<b>145° F (62.8° C)</b>	<b>Vegetables</b> .....	<b>145° F (62.8° C)</b>
<b>Poultry</b> .....	<b>165° F (82° C)</b>		

### **HELPFUL HINTS:**

- If you pre-cook meat or poultry, do so immediately before grilling.
- Never defrost meat at room temperature or on a countertop.
- Refrigerate leftovers within 2 hours of taking food off the griddle.
- For additional information, please phone the USDA's toll free Meat & Poultry Hotline at 800-535-4555.



# ASSEMBLY INSTRUCTIONS:

**⚠ READ ALL SAFETY WARNINGS & ASSEMBLY INSTRUCTIONS CAREFULLY BEFORE ASSEMBLING OR OPERATING YOUR GRIDDLE.**

**WE RECOMMEND TWO PEOPLE WORK TOGETHER WHEN ASSEMBLING THIS UNIT.**

The following tools are required to assemble this Even Embers 5 Burner Gas Griddle:

- **Phillips Screwdriver**

## PARTS LIST:

①	1	Lid Assembly	⑭	1	Left Rear Leg
②	1	Griddle	⑮	1	Left Side Cart Brace
③	1	Griddle Body Assembly	⑯	1	Left Front Leg
④	1	Left Side Table	⑰	1	Upper Leg Brace
⑤	1	Right Side Table	⑱	1	Front Panel
⑥	1	Lid Handle & Bezels Assembly	⑲	2	Lower Leg Brace
⑦	1	Grease Tube	⑳	1	Right Front Leg
⑧	1	Grease Bucket	㉑	1	Upper Right Side Cart Brace
⑨	6	Accessory Hooks	㉒	1	Right Rear Leg
⑩	2	Left Shelf Brackets	㉓	1	Lower Right Side Cart Brace
⑪	2	Right Shelf Brackets	㉔	1	Towel Rack Bar
⑫	2	Lid Hinge Pins & Nuts	㉕	4	Casters
⑬	8	Shelf Hinge Pins			

**Note:** Most hardware is pre-attached to the griddle. You may need to loosen some screws partially while others may need to be removed in order to assemble parts. The screws that you remove will be re-used so don't misplace this hardware.

Extra screws are included in a small bag with the owners manual.

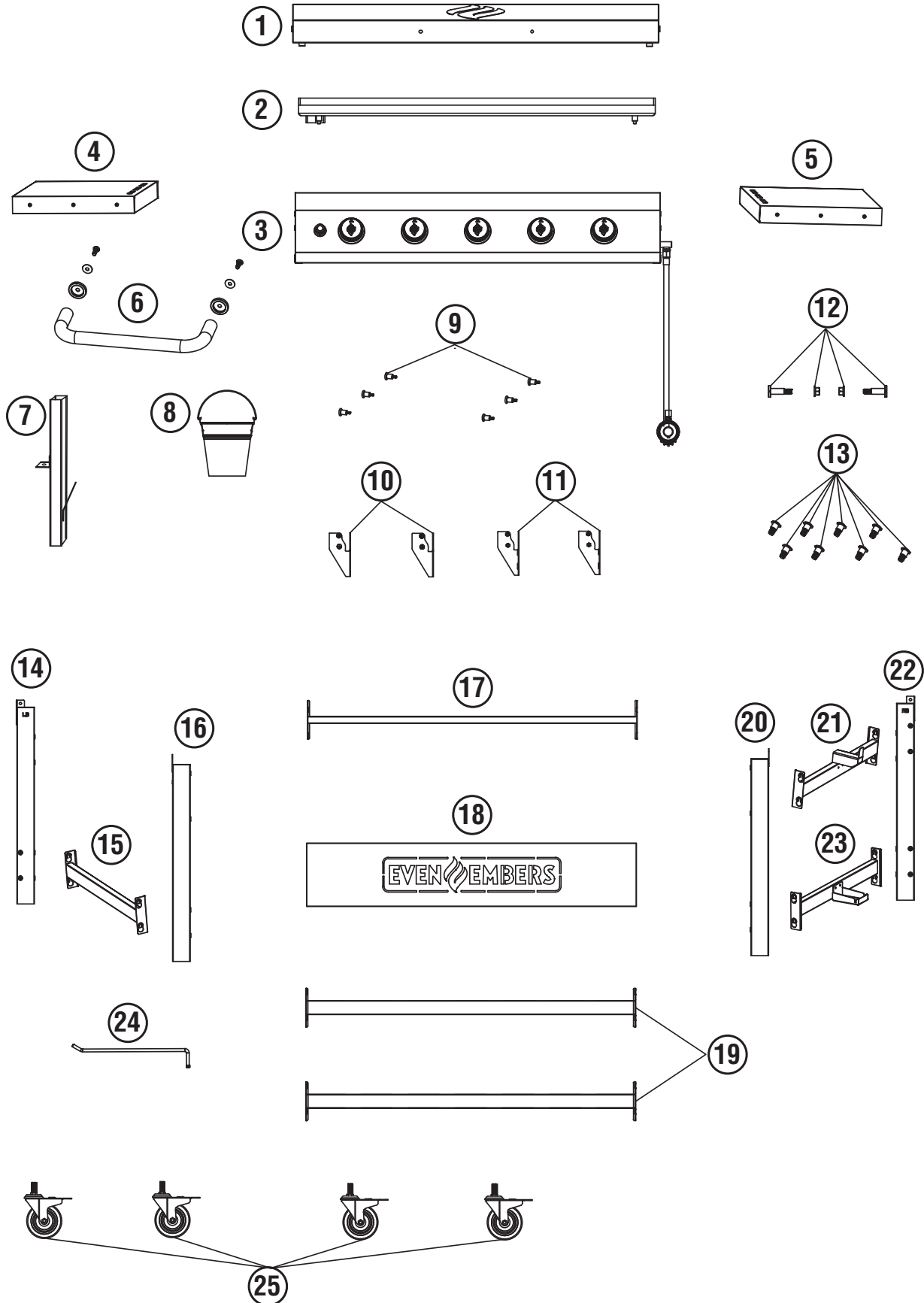

NOTE: Some screws are pre-assembled to the griddle. You may need to loosen some screws partially while others may need to be removed to assemble parts.

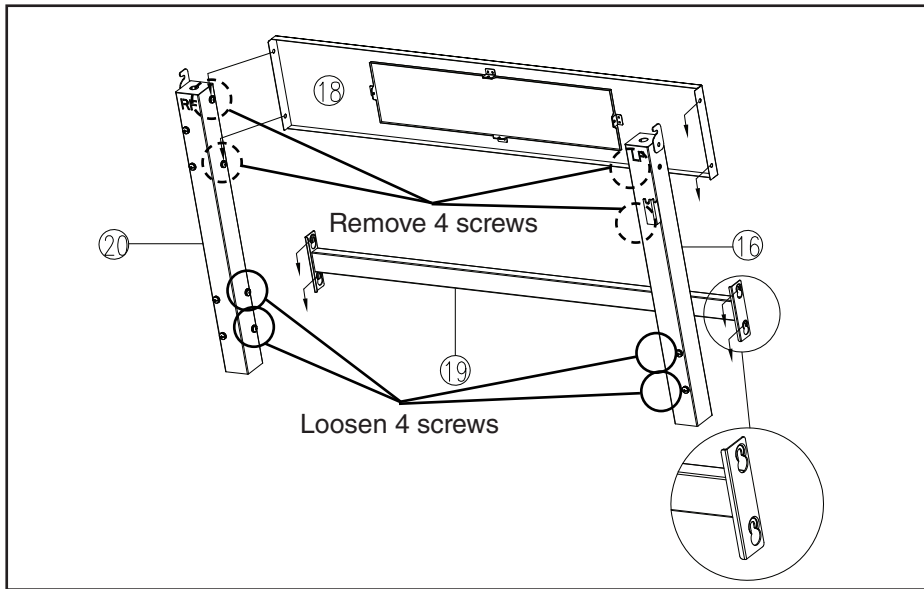

1

Remove four screws from front legs ⑳ and ⑯. Loosen four screws from front legs ⑳ and ⑯. Attach front panel ⑱ to front legs ⑳ and ⑯ using four screws. Attach lower leg brace ⑲ over keyholes. Tighten all screws.

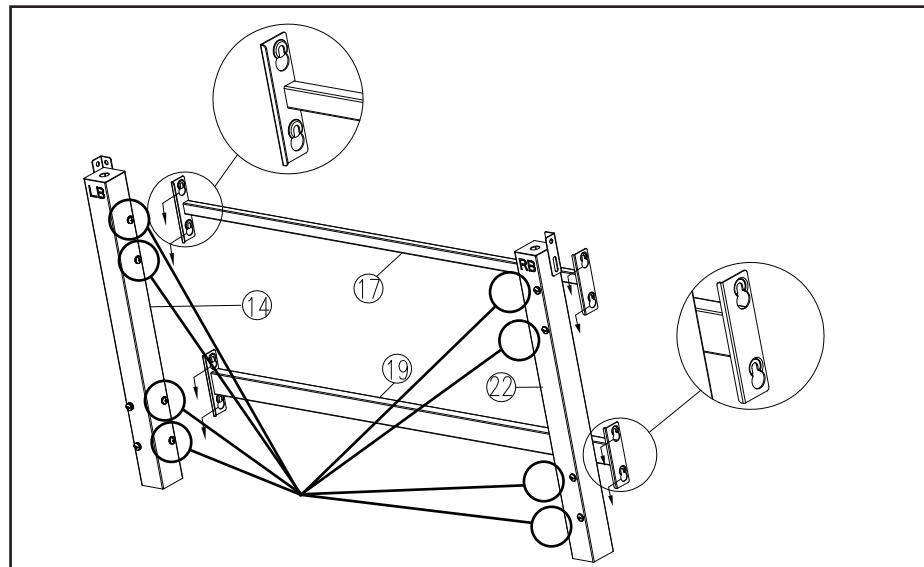

2

Loosen eight screws on rear legs ㉒ and ⑭. Attach upper and lower leg braces ⑰ and ⑲ to rear legs ㉒ and ⑭ using pre-attached screws over keyholes. Tighten all screws.

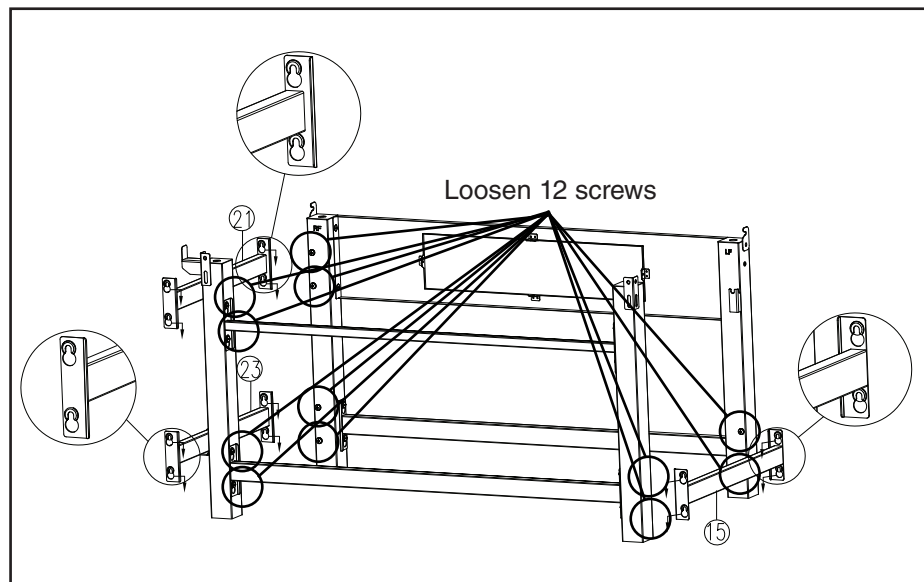

3

Loosen twelve screws on all legs. Attach upper and lower right side cart braces ㉑ and ㉓ and left side cart brace ⑮ using pre-attached screws over keyholes. Tighten all screws.

4

Lock the casters 25. Attach casters 25 to all four legs.

Unlocked



Locked

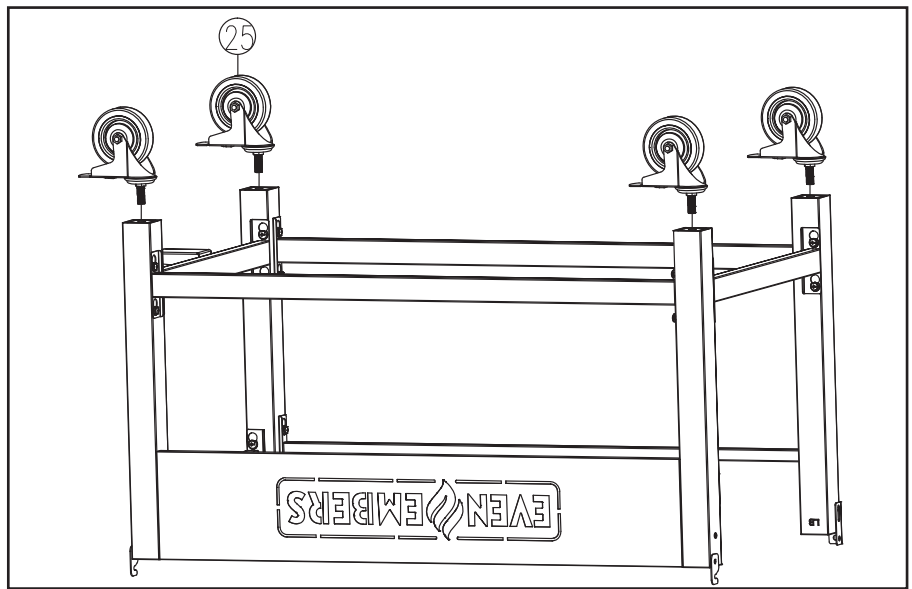

5

Remove four screws from sides of griddle body.

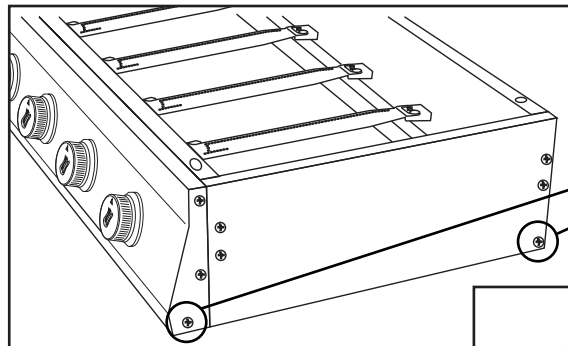

Remove 4 screws

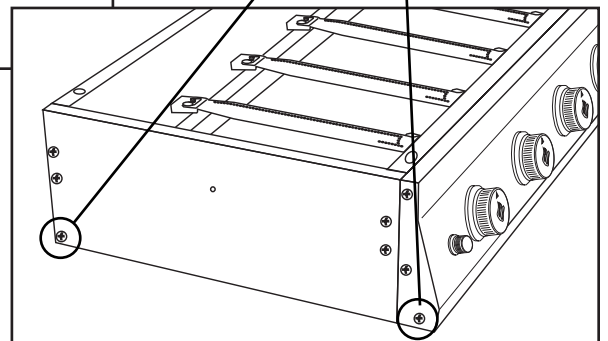

6

Set griddle body assembly 3 on cart frame. Secure using four screws removed in Step 5.

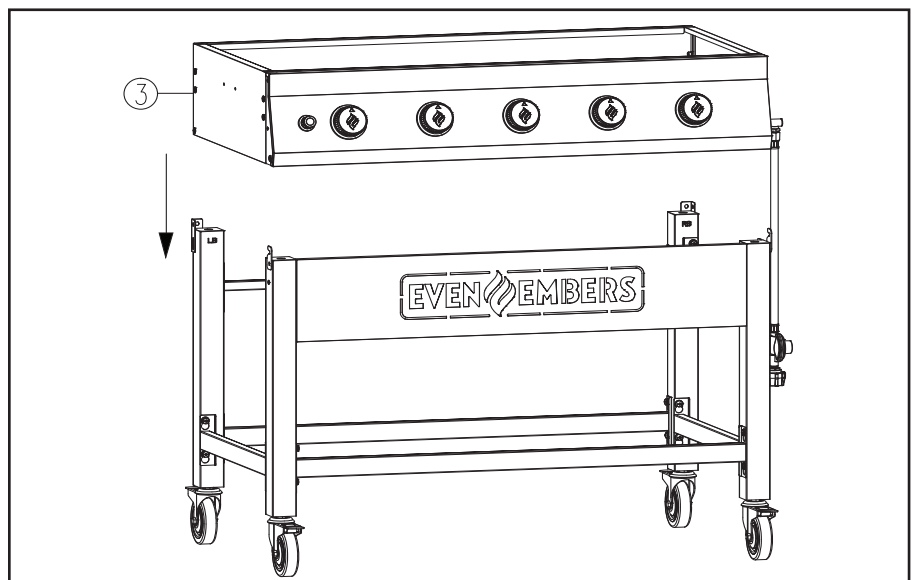

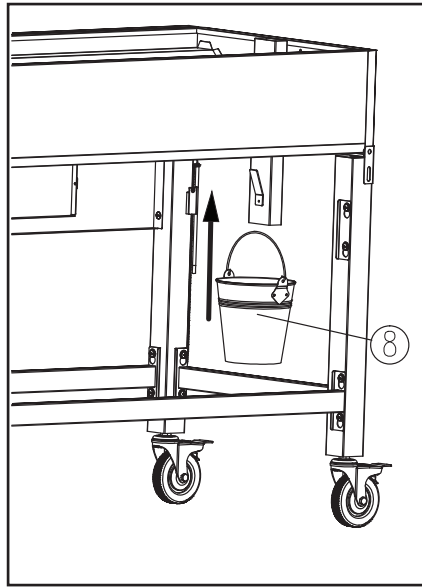
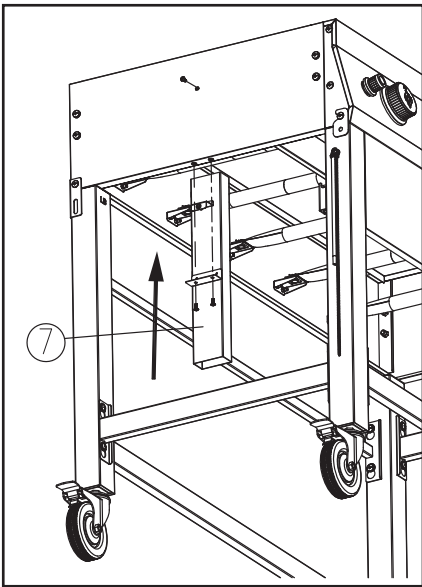

7

Attach grease tube 7 to griddle body using pre-attached screws.

Hang grease bucket 8 from grease tube.

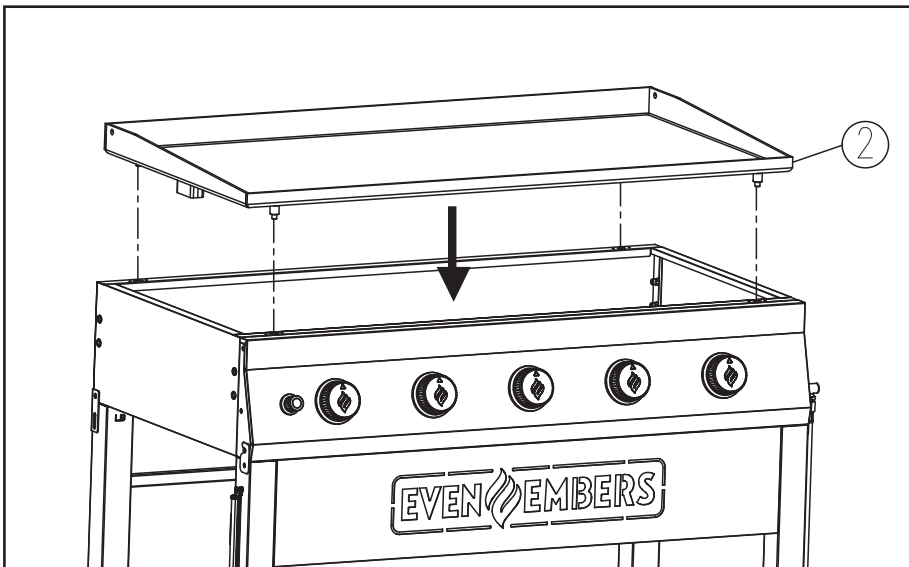

8

Place griddle 2 on cart frame. Griddle legs should fit into holes on top of cart frame.

Note: Make sure the hole in the griddle top aligns with the grease tube.

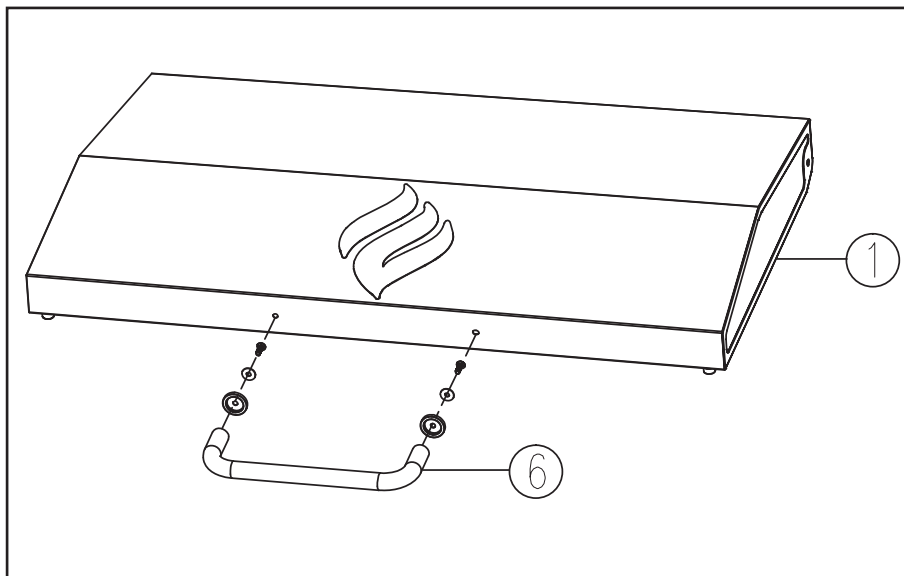

9

Attach lid handle 6 to lid 1 using two pre-attached screws, washers and bezels.

10

Attach lid ① to griddle ② using two lid hinge pins and nuts ⑫.

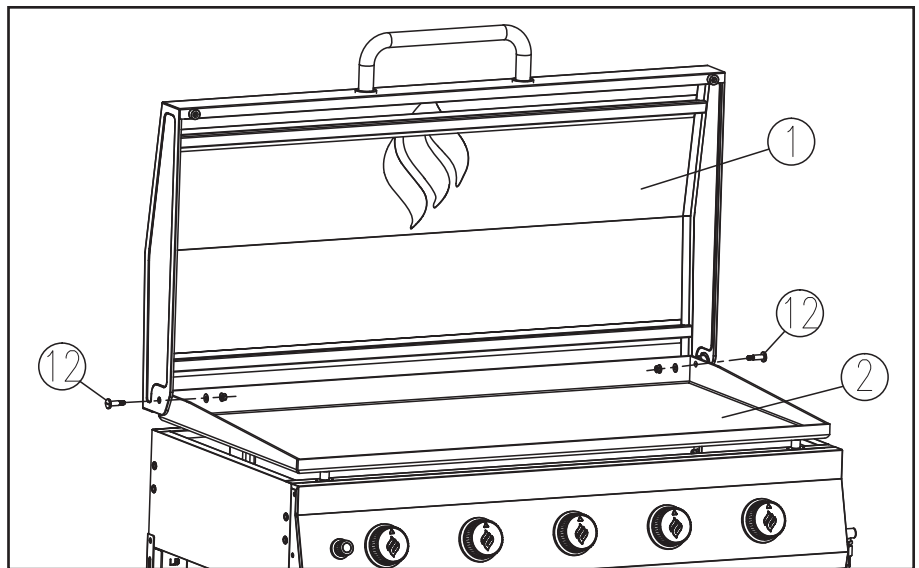

11

Attach accessory hooks ⑨ to left side table ④.

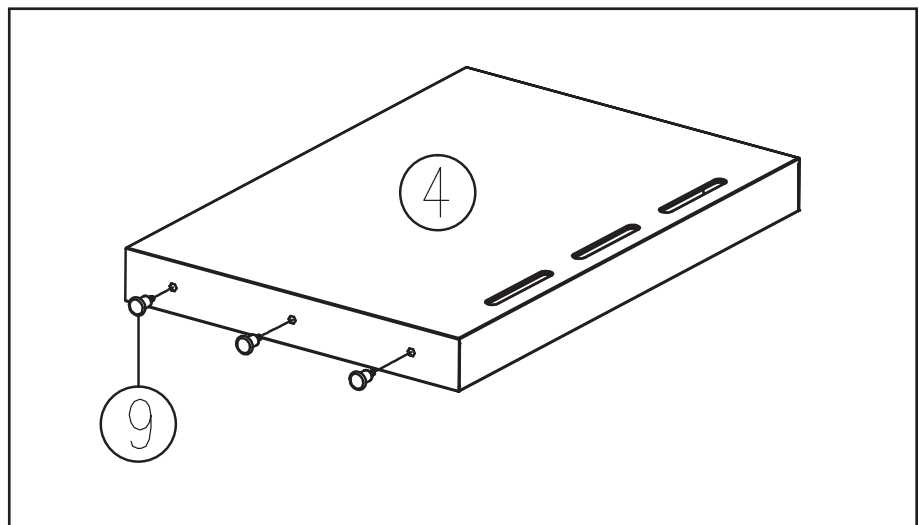

12

Attach side table brackets ⑩ and ⑪ to cart frame using four pre-attached screws. Install two lower shelf hinge pins ⑬, then attach left side table ④ and install two upper shelf hinge pins ⑬ to secure.

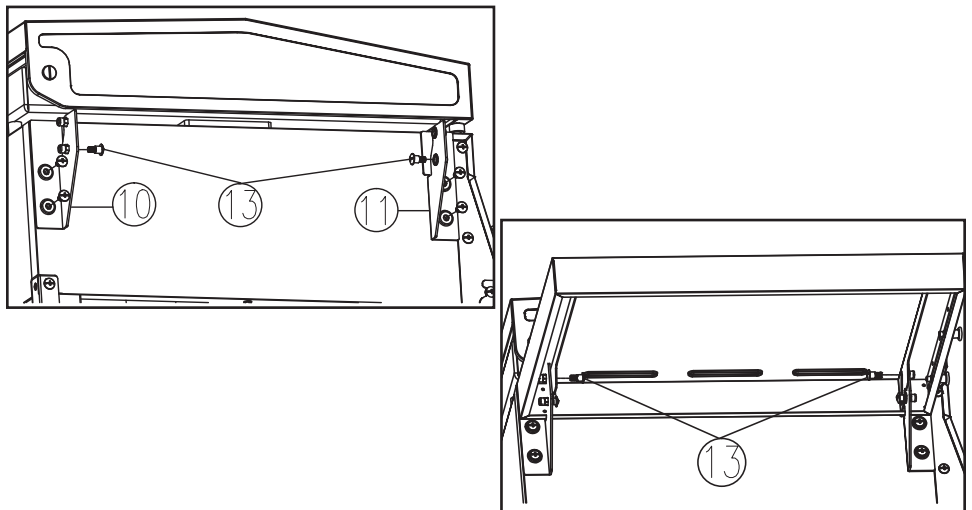

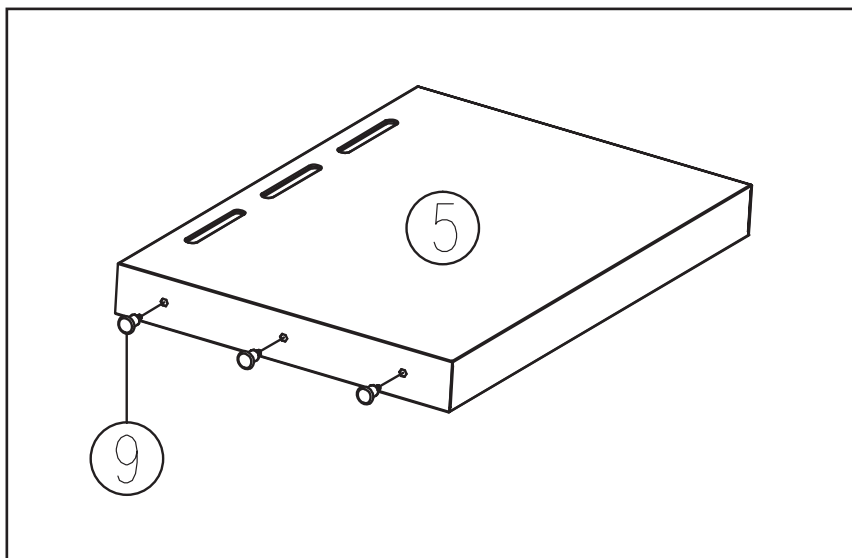

13

Attach accessory hooks (9) to right side table (5).

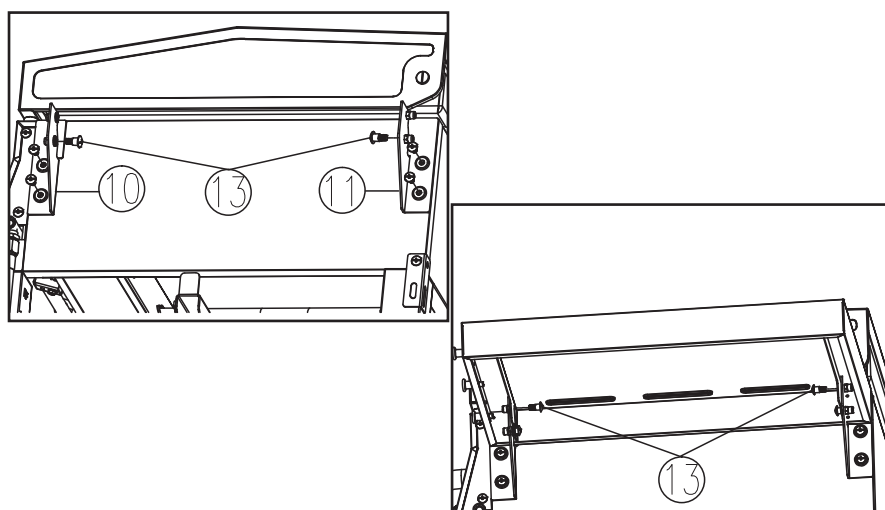

14

Attach side table brackets (10) and (11) to cart frame using four pre-attached screws. Install two lower shelf hinge pins (13), then attach right side table (5) and install two upper shelf hinge pins (13) to secure.

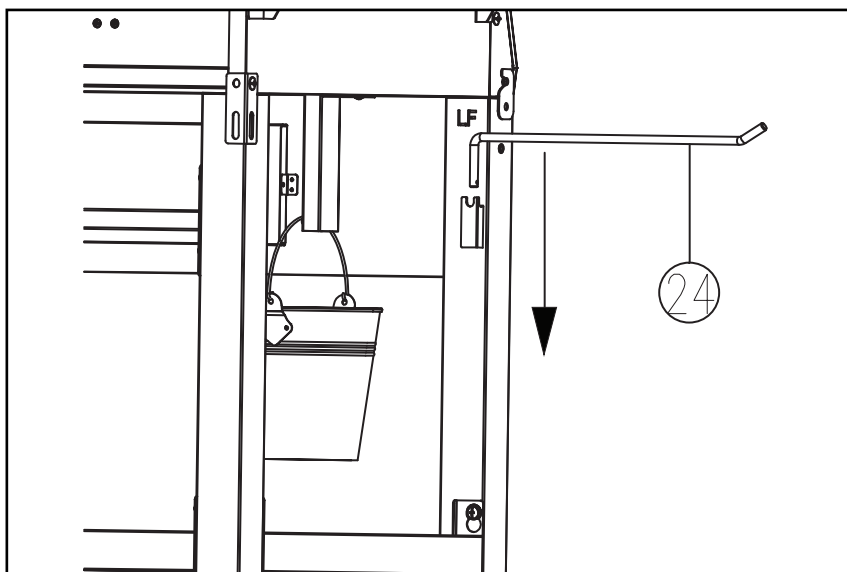

15

Install towel rack bar (24) in left front leg bracket.

## Even Embers GAS2540AS Assembled

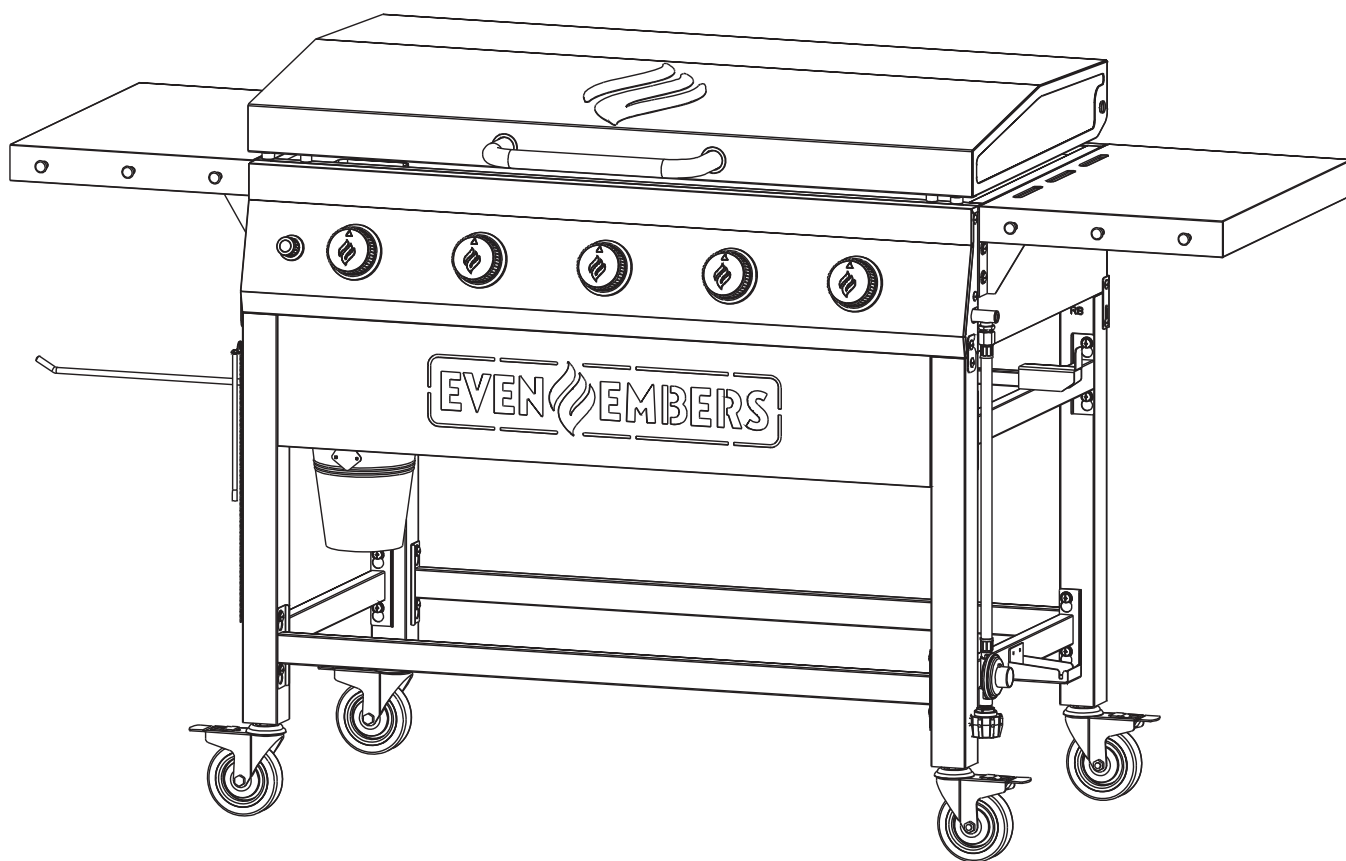



# WARRANTY

The Boltz Group warrants to the original purchaser that the Even Embers 5 Burner Gas Griddle is free from defects due to workmanship or materials for:

Ten-year: on stainless steel tube burners

Three-year: on all other stainless steel parts

One-year: on valves, frame, housing, cart, igniter, griddle and other related parts

The Boltz Group's obligations under this warranty are limited to the following guidelines:

- This warranty does not cover gas griddles that have been altered/modified or damaged due to: normal wear, rust, abuse, improper maintenance and/or improper use.
- This warranty does not cover surface scratches, rust or heat damage to the finish, which is considered normal wear.
- The Boltz Group may elect to repair or replace damaged units covered by the terms of this warranty.
- This warranty extends to the original purchaser only and is not transferable or assignable to subsequent purchasers.

The Boltz Group requires reasonable proof of purchase. Therefore, we strongly recommend that you retain your sales receipt or invoice. To obtain replacement parts for your Even Embers 5 Burner Gas Griddle under the terms of this warranty, please call Customer Service Department at 1-855-735-9922. A receipt will be required. The Boltz Group will not be responsible for any gas griddles forwarded to us without prior authorization.

EXCEPT AS ABOVE STATED, THE BOLTZ GROUP MAKES NO OTHER EXPRESS WARRANTY.

THE IMPLIED WARRANTIES OF MERCHANTABILITY AND FITNESS FOR A PARTICULAR PURPOSE ARE LIMITED IN DURATION TO THOSE LISTED ABOVE FROM THE DATE OF PURCHASE. SOME STATES DO NOT ALLOW LIMITATIONS ON HOW LONG AN IMPLIED WARRANTY LASTS, SO THE ABOVE LIMITATION MAY NOT APPLY TO YOU.

ANY LIABILITY FOR INDIRECT, INCIDENTAL OR CONSEQUENTIAL DAMAGES ARISING FROM THE FAILURE OF THE EVEN EMBERS 5 BURNER GAS GRIDDLE TO COMPLY WITH THIS WARRANTY OR ANY IMPLIED WARRANTY IS EXCLUDED. CUSTOMER ACKNOWLEDGES THAT THE PURCHASE PRICE CHARGED IS BASED UPON THE LIMITATIONS CONTAINED IN THE WARRANTY SET OUT ABOVE. SOME STATES DO NOT ALLOW THE EXCLUSION OR LIMITATION OF INCIDENTAL OR CONSEQUENTIAL DAMAGES, SO THE ABOVE LIMITATION OR EXCLUSION MAY NOT APPLY TO YOU. THIS WARRANTY GIVES YOU SPECIFIC LEGAL RIGHTS, AND YOU MAY ALSO HAVE OTHER RIGHTS WHICH VARY FROM STATE TO STATE.