

This Owner's Manual is provided and hosted by [Appliance Factory Parts](#).



# Farberware 455N Owner's Manual

[Shop genuine replacement parts for Farberware 455N](#)



[Find Your Farberware Small Appliance Parts - Select From 14 Models](#)

----- Manual continues below -----

FARBBERWARE®  
FARBBERWARE  
FARBBERWARE  
FARBBERWARE  
FARBBERWARE  
FARBBERWARE  
FARBBERWARE  
FARBBERWARE  
FARBBERWARE  
FARBBERWARE  
FARBBERWARE  
FARBBERWARE

OPEN HEARTH® BROILER-ROTISSERIE MODEL NO.'s 455N, 455ND

---

## IMPORTANT SAFEGUARDS

---

When using electrical appliances, basic safety precautions should always be followed, including the following:

1. Read all instructions.
2. Do not touch hot surfaces. Use handles.
3. To protect against electrical hazards do not immerse cords, plugs, heating element, or motor assembly in water or other liquid.
4. Close supervision is necessary when any appliance is used near children.
5. Unplug from outlet when not in use and before cleaning. Allow to cool before putting on or taking off parts.
6. Do not operate any appliance with a damaged cord or plug or after the appliance malfunctions, or has been damaged in any manner. Return appliance to the nearest Farberware service facility for examination, repair or adjustment.
7. The use of accessory attachments not recommended by Farberware may cause hazards.
8. Do not use outdoors.
9. Do not let cord hang over edge of table or counter, or touch hot surfaces.
10. Do not place on or near a hot gas or electric burner, or in a heated oven.
11. Extreme caution must be used when moving an appliance containing hot oil or other hot liquids.
12. Always attach plug to appliance first, then plug cord into the wall outlet; to disconnect, remove all plugs from wall outlet.
13. Do not use appliance for other than intended household use.
14. Use extreme caution when removing tray or disposing of hot grease.
15. Do not clean with metal scouring pad. Pieces can break off the pad and touch electrical parts, creating a shock hazard.

---

## SAVE THESE INSTRUCTIONS

---

It is recommended that only FARBERWARE cord sets be used with this FARBERWARE appliance.

## INTRODUCTION

The secret of the Farberware® Open Hearth® Broiler-Rotisserie is out in the open. By cooking food in an open environment, the Open Hearth® allows air to circulate freely around food, letting it "breathe". This process seals in natural juices while unwanted fat drains off. Open Hearth cooking assures more flavorful and nutritious meats, poultry and fish.

The Open Hearth Broiler-Rotisserie cooks with no smoke and virtually no spatter. Unlike conventional electric broilers, the Open Hearth heating element is positioned below the grill, while the specially designed drip tray disperses the heat evenly, eliminating most spatter.

With the Open Hearth Broiler-Rotisserie foods look and taste as good as they were meant to. Slow, even cooking produces picture-perfect browning on the outside and the desired degree of doneness on the inside. Roasts are juicier, chickens more flavorful, fish more moist, ducks crispier—and all more delicious with less fat.

The Rotisserie sets up quickly and can be used in seven different positions for optimum cooking results. The Broiler Rack is adjustable to high or low height. Cleaning is simple with many parts dishwasher-safe (see "CARE AND CLEANING".) For compact storage the Open Hearth easily disassembles.

The cooking charts and recipes included in this book are designed to help you enjoy the Farberware Open Hearth Broiler-Rotisserie to its fullest. From light and flavorful Dilled Salmon Steaks to the hearty Beef Roast Western-Style, cooking with the Farberware Open Hearth Broiler-Rotisserie is an experience you'll enjoy time and time again.

## UNDERSTANDING THE PARTS

(see diagram)

The FRAME AND HANDLE ASSEMBLY is made of chrome-plated steel with high impact- and heat-resistant plastic. It holds the stainless steel BODY in position for proper heat reflection and air circulation. The stainless steel CROSSBAR helps to secure the HEATING ELEMENT in a level position. The aluminum DRIP TRAY is set under the HEATING ELEMENT and BODY to catch drippings and aid in heat reflection for optimum cooking results. The HEATING ELEMENT is plugged into the CORD SET that is inserted into the BROILER PLUG RECEPTACLE. The chrome-plated STEEL BROILING RACK rests legs down in the BODY for the high position and inverted for the low position.

When using the Rotisserie, the SPIT SUPPORTS fit into the SPIT SUPPORT RECEPTACLES on the FRAME AND HANDLE ASSEMBLY. The SPIT AND HANDLE are screwed together and the HOLDING FORKS AND SCREWS are slipped onto the spit with the prongs facing each other. The HOLDING FORKS AND SCREWS will securely hold food to be cooked on the Rotisserie. The SPIT AND HANDLE holding the food is slowly rotated over the HEATING ELEMENT by means of the MOTOR AND PLUG.

## BEFORE USING FOR THE FIRST TIME

Before using for the first time, wash and dry all parts of the Broiler-Rotisserie with the exception of the HEATING ELEMENT, CORD SET and MOTOR AND PLUG.

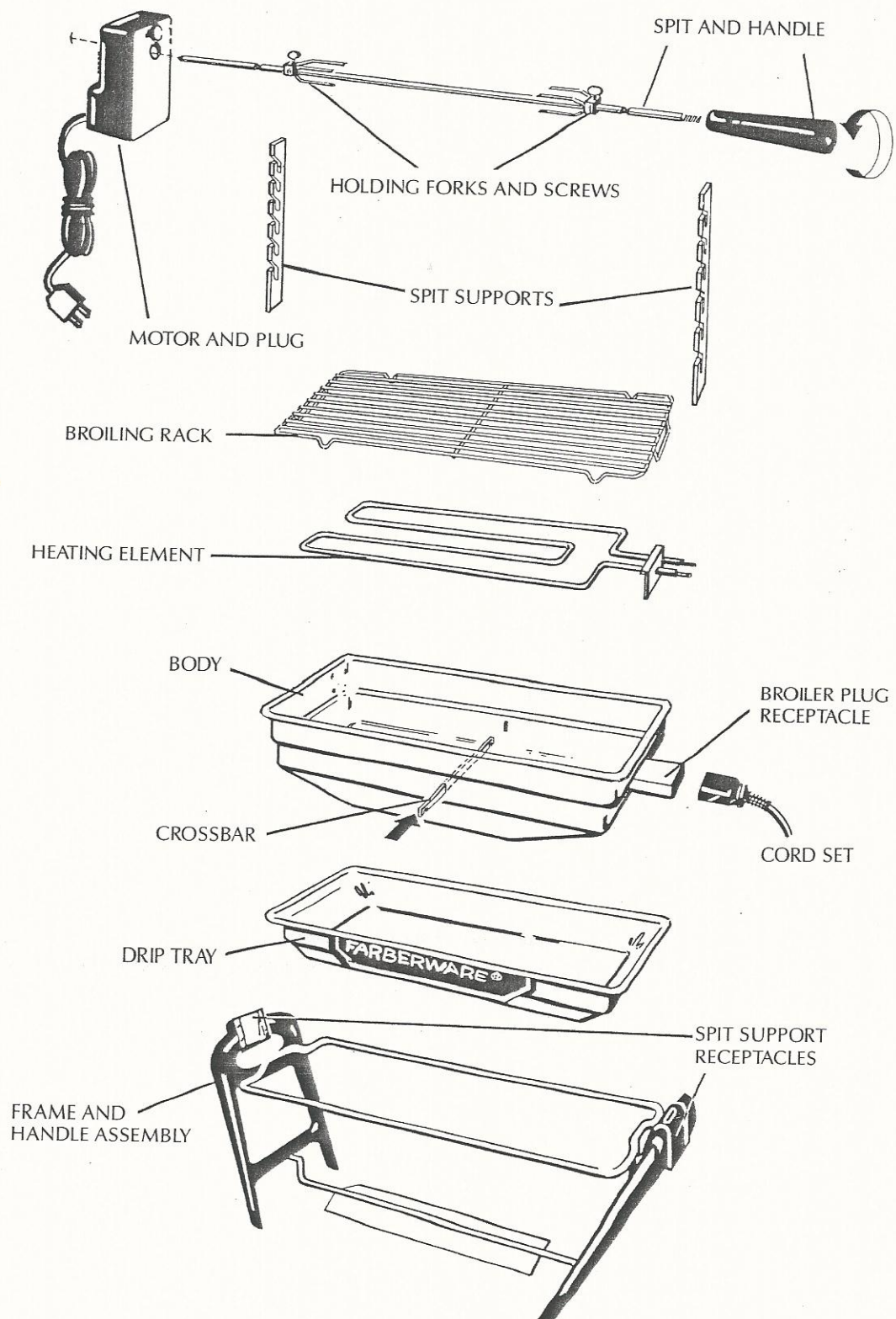

## HOW TO ASSEMBLE THE BROILER

1. Place the DRIP TRAY so it fits into place on the bottom of the FRAME AND HANDLE ASSEMBLY.
2. Place the BODY into position making sure the BROILER PLUG RECEPTACLE is positioned under the handle on the right side of the FRAME AND HANDLE ASSEMBLY.
3. Insert the CROSSBAR into the slots found in the center of the BODY.
4. Place the HEATING ELEMENT so the two prongs fit through the BROILER PLUG RECEPTACLE and the brackets of the HEATING ELEMENT (located near prongs) fit into the slots of the BODY located on either side of the BROILER PLUG RECEPTACLE.
5. Attach CORD SET to prongs of HEATING ELEMENT. Plug cord into 120 volt AC outlet. Always plug cord into appliance first, then into outlet. At this time, no other appliance should be plugged into this circuit.
6. Preheat until HEATING ELEMENT is hot, about 1 minute.
7. Carefully place the BROILING RACK on the ledge of the BODY. Use extreme care as HEATING ELEMENT is hot. (See charts and/or recipes for correct position.)
8. Place food on BROILING RACK and cook as desired.

PLACE BROILER ON COUNTER SO THAT IT IS NOT UNDERNEATH CABINETS OR OTHER STRUCTURE. DO NOT USE ALUMINUM FOIL OR ANY OTHER MATERIAL THAT WILL INTERFERE WITH THE FLOW OF AIR IN THE DRIP TRAY OR ON THE BODY.

## HOW TO ASSEMBLE THE ROTISSERIE

1. Follow the instructions above, "HOW TO ASSEMBLE THE BROILER" through step number 4.
2. Insert SPIT SUPPORTS into SPIT SUPPORT RECEPTACLES on FRAME AND HANDLE ASSEMBLY. The long ends of the SPIT SUPPORTS should fit into the RECEPTACLES and the open slots of the SUPPORTS pointed upward and facing you.
3. Attach CORD SET to prongs of HEATING ELEMENT. Plug cord into 120 volt AC outlet. Always plug cord into appliance first, then into outlet. At this time, no other appliance should be plugged into this circuit.
4. Preheat until HEATING ELEMENT is hot, about 1 minute.
5. To assemble spit, screw together HANDLE and SPIT in a counter clockwise (left) direction.
6. Slide one pronged HOLDING FORK into spit with prongs facing the center. Place food on SPIT so that it is balanced. Slide second HOLDING FORK onto SPIT. Pierce food with prongs of HOLDING FORK to secure. Check again that food is balanced on SPIT and tighten screws on HOLDING FORK to hold food in place.
7. Insert pointed end of SPIT into MOTOR.
8. Positioning motor on opposite side from BROILER PLUG RECEPTACLE, carefully slide MOTOR and SPIT with food into open slots on SPIT SUPPORTS so the food is as close to HEATING ELEMENT as possible without touching it. MOTOR will lock into place.
9. Connect MOTOR PLUG to 120 volt AC wall outlet to start Rotisserie.

PLACE BROILER-ROTISSERIE ON COUNTER SO THAT IT IS NOT UNDERNEATH CABINETS OR OTHER STRUCTURE. DO NOT USE ALUMINUM FOIL OR ANY OTHER MATERIAL THAT WILL INTERFERE WITH THE FLOW OF AIR IN THE DRIP TRAY OR ON THE BODY.

## HOW TO USE A MEAT THERMOMETER

A meat thermometer is the most accurate test to determine the degree of doneness of meat, especially roasts, but even then it is only a guide. Insert the heat-resistant thermometer into the roast after the meat has been balanced on the spit. Push the metal tip into the thickest part of the meat. It should be parallel to the spit at the handle end. Be sure the thermometer does not touch the bone or the spit and does not rest in a fat pocket. Before turning on the motor check the clearance—the thermometer must not touch the heating element. A thermometer is not practical for small cuts of meat, chops, Cornish Hens, etc.

In turkeys, chickens and ducklings the thickest part of the meat is between the breast and the thigh. This is where the thermometer should be inserted, avoiding bone, fat and the spit. It is sometimes difficult to be assured of an accurate thermometer reading when rotisserieing poultry. As a second test of doneness, large birds are done when the thickest part of the drumstick feels very soft when pressed with fingers (be careful, the skin will be hot). Juices will also run clear.

Many meats will continue to cook after removal from the Broiler-Rotisserie. For example, beef will increase about 10 degrees in internal temperature upon sitting. After removing meat or poultry, a standing time of 15 or 20 minutes is recommended to allow for this additional cooking and to make carving easier.

## CARE AND CLEANING

When cooking has been completed, remove food from rack or stop spit from rotating and remove food. Remove plug of cord set from outlet. Allow Broiler-Rotisserie to cool completely. When cool, separate parts. If necessary, wipe cord set and motor and plug with a damp cloth. Dry completely and set aside. The heating element is self-cleaning—DO NOT WASH.

All of the remaining parts can be washed in hot, sudsy water or placed in the dishwasher. DO NOT CLEAN PARTS OF BROILER-ROTISSERIE WITH A METAL SCOURING PAD OR AN ABRASIVE CLEANSER AS SURFACE SCRATCHING MAY OCCUR. Soaking parts in hot, sudsy water will make cleaning easier. If necessary, use a plastic mesh pad and/or non-abrasive stainless steel cleaner such as "Bon Ami", "Kleen King" or "Cameo". Rinse parts thoroughly and dry completely. Reassemble the Broiler-Rotisserie for storage.

ALL REPLACEMENT PARTS FOR THE BROILER-ROTISSERIE SHOULD BE AUTHORIZED FARBERWARE PARTS.

## BROILING CHART

Broiling is a method of cooking food by setting it on a rack and exposing the food to direct heat. This style of cooking is usually reserved for the more tender cuts of meat.

Broiling times stated in the chart and recipes are for refrigerator temperature foods. These times are provided as a guide and may vary with the thickness and/or temperature of food to be broiled. Browning is increased the longer each side of the food is exposed to the heating element. The amount of fat on the meat, the dryness of the meat surface and the addition of seasoning salt, soy sauce, steak sauce or marinating will help to produce a brown appearance. Always remove the meat from the rack before the broiler is unplugged.

| VARIETY OF MEAT         | CUT                      | WT/SIZE  | RACK POSITION | Approximate Total Cooking Time<br>(turn as desired) |            |                          | COMMENTS              |
|-------------------------|--------------------------|----------|---------------|---|------------|--------------------------|-----------------------|
|                         |                          |          |               | RARE  | MEDIUM     | WELL                     |                       |
| BEEF                    | T-Bone Steak             | 1½ in.   | low           | 26-30 min.  | 36-38 min. | 42-44 min.               |                       |
|                         |                          | 2 in.    | low           | 32-36 min.  | 44-46 min. | 50-58 min.               |                       |
|                         | Sirloin Steak            | ¾-1 in.  | low           | 18-20 min.  | 22 min.    | 24 min.                  |                       |
|                         |                          | 1½ in.   | low           | 20-24 min.  | 26-28 min. | 28-32 min.               |                       |
|                         | Chuck Steak              | ¾-1 in.  | low           | 18-22 min.  | 24-26 min. | 28-32 min.               |                       |
|                         | Boneless Top Round Steak | ¾-1 in.  | low           | 30-34 min.  | 36 min.    | 38-40 min.               |                       |
|                         | Flank Steak              | 1¼-2 lb. | low           | 20-22 min.  | 24-26 min. | 26-28 min.               |                       |
| Hamburgers              | ½ in.                    | low      | 12-14 min.    | 14-16 min.  | 16-18 min. |                          |                       |
| Hot Dogs                |                          |          | high          |   | 10-12 min. |                          |                       |
| Liver                   | ½ in.                    | low      |               | 4-6 min.  |            | Brush with melted butter |                       |
| SMOKED PORK             | Ham Slice Fully Cooked   | ¾ in.    | low           |   |            | 14 min.                  |                       |
|                         | Canadian Bacon           | ¼ in.    | low           |   |            | 8 min.                   |                       |
|                         | Bacon                    | ⅛ in.    | high          |   |            | 14-20 min.               |                       |
| FRESH PORK              | Chops                    | ½-¾ in.  | low           |   |            | 28-30 min.               |                       |
|                         |                          | ¾-1 in.  | low           |   |            | 32-34 min.               |                       |
|                         | Spareribs                | 1½-2 lb. | high          |   |            | 60-70 min.               | Glaze during broiling |
|                         | Fresh Sausage            |          | high          |   |            | 28-30 min.               |                       |
| Brown -n- Serve Sausage |                          | low      |               |   | 10-12 min. |                          |                       |

| VARIETY OF MEAT | CUT                           | WT/SIZE    | RACK POSITION | Approximate Total Cooking Time<br>(turn as desired) |            |            | COMMENTS                               |
|-----------------|-------------------------------|------------|---------------|---|------------|------------|--|
|                 |                               |            |               | RARE  | MEDIUM     | WELL       |  |
| LAMB            | Rib Lamb Chops                | 1 in.      | low           | 20-22 min.  | 25-27 min. | 30-34 min. |  |
|                 |                               | 1½ in.     | low           | 26-30 min.  | 34-36 min. | 40-46 min. |  |
| VEAL            | Rib Chops                     | ¾ in.      | low           |   |            | 28-30 min. |  |
| POULTRY         | Broiler Fryer Chicken, split  | 1½ - 3 lb. | high          |   | 45-50 min. |            | Brush with melted butter               |
|                 | Chicken Breasts, halved       | 1-6 lb.    | high          |   | 40-45 min. |            |  |
|                 | Duckling, split               | 4-6 lb.    | high          |   | 60-80 min. |            | Glaze duckling last 20 min. of cooking |
| FISH            | Fillets                       | ⅛ in.      | high          |   |            | 10 min.    | Brush with melted butter               |
|                 |                               | ½-¾ in.    | high          |   |            | 16 min.    |  |
|                 |                               | ¾-1 in.    | high          |   |            | 18-20 min. |  |
|                 | Steaks                        | 1¼ in.     | high          |   |            | 30-34 min. | Brush with melted butter               |
|                 | Whole, cleaned                | 1¼ in.     | high          |   |            | 40-42 min. | Brush rack and fish with melted butter |
|                 | Scallops                      | large      | high          |   |            | 10-14 min. | Brush with melted butter               |
|                 | Shrimp                        | large      | high          |   |            | 14-16 min. | Brush with melted butter               |
|                 | Frozen Lobster Tails (thawed) | 6 oz. ea.  | high          |   |            | 15-18 min. | Brush with melted butter               |

## ROTISSERIE CHART

Spit roasted meats are extra flavorful because they are self-basted with their own juices. Foods are more healthful as fat can drip down and away from food during cooking.

Food to be cooked on the rotisserie must be no longer than 12-inches so that the entire piece may be placed over the heating element. Weight of food to be cooked is less important than the length.

Food should be carefully balanced on the spit, as off-center pieces will cause a jerking during cooking that may affect the performance of the motor. This is especially true of meats with the bone in. Properly balanced food can usually be judged by the eye; however, test for balance by rotating the spit in the palm of your hands. Secure food so that it turns only with the turn of the spit.

To ensure proper cooking remove broiling rack and set food as close to the heating element as possible without touching the heating element. Poultry should be tied or fastened at wings and legs to make a compact bird so that no part touches the heating element when roasting.

Suggested roasting time in the chart and recipes are for refrigerator temperature foods. Times are provided as a guide and may vary with the thickness, shape and/or temperature of food to be cooked.

| VARIETY OF MEAT | CUT                                      | WT/SIZE  | Approximate Total Cooking Time* |                |              | COMMENTS**   |
|-----------------|--|----------|---------------------------------|----------------|--------------|--|
|                 |  |          | RARE (130°F)                    | MEDIUM (150°F) | WELL (170°F) |  |
| BEEF            | Rump, boned and tied                     | 2½-3 lb. | 1¼-1½ hr.                       | 1½-1¾ hr.      | 1¾-2 hr.     | diameter 4-5½ in.  |
|                 | Eye of Round                             | 4-4½ lb. | 1¼-½ hr.                        | 1½-1¾ hr.      | 2 hrs.       | diameter 3-5½ in.  |
|                 | Sirloin Tip, tied                        | 4½-5 lb. | 1¼-1½ hr.                       | 1½-1¾ hr.      | 1¾-2 hr.     | diameter 4-5 in.   |
|                 | Rib Roast, boned and tied                | 6-6½ lb. | 2½-2¾ hr.                       | 3 hrs.         | 3¼ hrs.      |  |
|                 | Standing Rib                             | 4-5 lb.  | 1¼-1½ hr.                       | 1½-1¾ hr.      | 1¾-2 hr.     | Length when tied is about 7½ in. Run spit through meat parallel to bone. |
| PORK            | Smoked ham bone in, fully cooked         | 4-6 lb.  |                                 |                | 1½-2 hr.     | Internal temperature when removed from spit 140°F.                       |
|                 | Smoked Picnic Ham, boneless fully cooked | 4½ lb.   |                                 |                | 2 hrs.       | Internal temperature when removed from spit 140°F.                       |
|                 | Fresh Ham                                | 5-5½ lb. |                                 |                | 3½-3¾ hr.    | Internal temperature when removed from spit 170°F.                       |
|                 | Loin, bone in                            | 3-3½ lb. |                                 |                | 2¼-2½ hr.    | Internal temperature when removed from spit 170°F.                       |

\* The listed meats except Cornish Hen or small chicken should be allowed to sit 15-20 minutes after removing from spit. Internal temperature will rise 10°F upon sitting and slicing will be easier.

\*\* The diameter of a roast governs the cooking time. Example: A 6 lb. 4 inch diameter rolled roast cooks for the same length of time as a 4 lb. 4 inch diameter roast.

| VARIETY OF MEAT | CUT                                     | WT/SIZE   | Approximate Total Cooking Time* |                |              | COMMENTS**   |
|-----------------|---|-----------|---------------------------------|----------------|--------------|--|
|                 |   |           | RARE (130°F)                    | MEDIUM (150°F) | WELL (170°F) |  |
| PORK            | Loin boned and tied                     | 2½-3 lb.  |                                 |                | 1½ hr.       | Internal temperature when removed from spit 170°F. |
|                 | Spareribs                               | 1-4 lb.   |                                 |                | 1½-2 hr.     | Lace ribs onto spit; baste with sauce last 20 min. |
|                 | Smoked Shoulder Butt                    | 2 lb.     |                                 |                | 1¼ hr.       | Internal temperature when removed from spit 170°F. |
| LAMB            | Leg, bone in                            | 3¾ lb.    |                                 |                | 2¼-2¾ hr.    | Internal temperature when removed from spit 170°F. |
| VEAL            | Boned and Rolled Rump or Shoulder Roast | 4½-6 lb.  |                                 |                | 2¼-2¾ hr.    | Internal temperature when removed from spit 170°F. |
| POULTRY         | Chicken                                 | 2-3 lb.   |                                 |                | 1½ hr.       | Internal temperature when removed from spit 180°F. |
|                 |   | 3-4 lb.   |                                 |                | 1¾-2 hr.     |  |
|                 | Cornish Hen                             | 1½-2 lb.  |                                 |                | 1¼-1½ hr.    |  |
|                 | Turkey                                  | 12-13 lb. |                                 |                | 4-4½ hr.     | Internal temperature when removed from spit 180°F. |
| 15-17 lb.       |   |           |                                 | 5-5½ hr.       |              |  |
|                 | Duckling                                | 4-6 lb.   |                                 |                | 2¼-2¾ hr.    | Internal temperature when removed from spit 180°F. |

\* The listed meats except Cornish Hen or small chicken should be allowed to sit 15-20 minutes after removing from spit. Internal temperature will rise 10°F upon sitting and slicing will be easier.

\*\* The diameter of a roast governs the cooking time. Example: A 6 lb. 4 inch diameter rolled roast cooks for the same length of time as a 4 lb. 4 inch diameter roast.

## COOKING HINTS AND TIPS

The following are hints and tips provided to help you benefit the most from your Farberware "Open Hearth" Broiler-Rotisserie.

### MEAT

Meat for broiling and spit roasting should be at refrigerator temperature (40°F). If meat is partially frozen when placed on the rack or spit, extra cooking time must be allowed. When selecting meat cuts for the Broiler-Rotisserie remember the following:

#### BEEF

Buy high quality beef that is bright red in color and is well marbled with veins of fat through the lean. Surrounding fat should be white and brittle. Select tender cuts meant to be broiled or roasted.

#### PORK

Good quality pork is firm, pink and slightly marbled with fat. Surrounding fat should be white and firm. Always cook pork until well done with no trace of pink (internal temperature of 170°F. to 180°F).

#### LAMB

Select young lamb that is light pink in color and has creamy white fat. For broiling have chops cut extra thick. In order to balance a bone-in Leg of Lamb properly on the spit it is sometimes easier if the shank end is removed. Lamb is best when cooked to medium or medium well (internal temperature 150°F to 160°F).

#### VEAL

This meat should be a light gray-pink. There should be very little surrounding fat and no marbling of fat through the lean.

### POULTRY

Select poultry that has smooth thin skin, tender meat and has the fat evenly distributed. Never store whole poultry more than 1 or 2 days in the refrigerator—cut-up poultry should be used within 24 hours.

It is best to thaw frozen poultry before cooking to ensure even, tender cooking. Remove giblets and neck as soon as they can be loosened. If poultry is partially frozen when placed on the cooking rack or spit, extra cooking time must be allowed.

When broiling poultry, select young tender birds. The sign of young poultry is a flexible breastbone, skin that tears easily and has evidence of pinfeathers. Spit-roasting is a longer, slower cooking method and can accommodate older, roasting-type poultry. Roasting poultry is larger than broiling-type poultry. When cooking poultry on the rotisserie, always fasten it so that it is as compact as possible. Be sure that no parts of the poultry and no string used in tying touches the heating element during the spit's rotation.

## HOW TO PLACE POULTRY ON THE SPIT FOR ROTISSERIE COOKING

(see diagrams below)

1. Place one of the holding forks on spit at handle end so that prongs point away from handle and bottom of fork is about 1-inch past center loop of heating element (See Figure 1). Secure holding fork with screw.
2. Insert spit through chicken from tail to neck. Fold tail against body of bird. Push two prongs of holding fork into end of chicken so that one prong holds tail against body and the other prong passes into skin covering breast bone (See Figure 2).
3. Push spit in further so that remaining two prongs go into soft skin between legs and body of chicken (See Figure 2).
4. Put spit in a vertical (up and down) position with handle on work counter. Push chicken tight onto holding fork.
5. At neck of bird, lift spit as far as possible up toward point of breast.
6. Put second holding fork on spit. Push into chicken so that prongs are completely inside flesh. Secure holding fork with screw. Chicken should be held so that it will not slip as the spit turns.
7. Using one length of string, tie chicken so that wings and legs do not hit heating element. This may be accomplished by first centering string under back of chicken. Bring string up over wings, down between breast and legs and cross under tail bone. Bring each end of string up and wrap around end of each leg. Tie ends together. Trim ends of string close to the knot (See Figure 3).

Note: Turkey can be placed on the spit in a similar manner. Do allow for the added length of the turkey and center over heating element.

When tying poultry try to avoid bringing the string across the bird's breast. This practice creates string marks during cooking and may break the skin, causing a loss of juices.

Should you want to stuff poultry to be roasted do so before placing it on the spit. It is also a good idea to close the cavity with poultry lacing or wooden picks. This will prevent the stuffing from falling out while the spit rotates.

### GENERAL

When broiling, the low rack position is ideal for broiling steaks or chops. The high position is suggested for meats that burn with intense heat (such as spareribs) or white meats (veal), poultry or fish.

Times of broiling and spit-roasting may vary with voltage in your home, temperature of meat and shape of meat. For example a 4 pound roast 4-inches in diameter may cook faster than a 4 pound roast 6-inches in diameter.

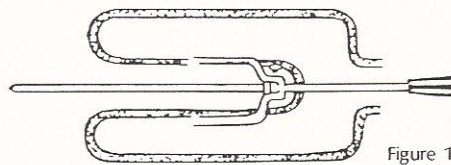

Figure 1

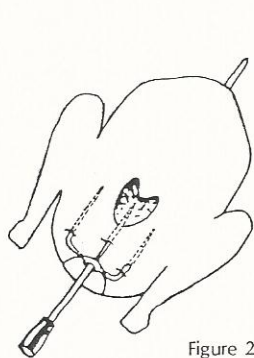

Figure 2

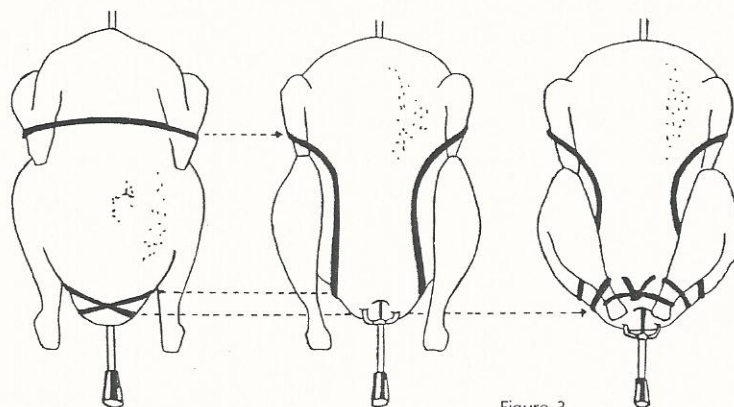

Figure 3

## BROILED STUFFED MUSHROOMS

- 24 large mushrooms, stems removed and chopped
- 2 tablespoons butter or margarine
- 1/4 cup chopped onion
- 1 1/2 cups flavored bread crumbs
- 1 cup finely chopped cooked ham
- 1/4 cup heavy cream
- 1 1/2 teaspoons prepared mustard
- 1/2 teaspoon pepper
- 2 tablespoons butter or margarine, melted

Melt 2 tablespoons of butter in a small skillet. Add chopped mushroom stems and onion. Sauté 4 to 5 minutes. Remove mixture to a bowl. Add remaining ingredients except 2 tablespoons melted butter. Mix well and set aside. Dip mushroom caps into reserved melted butter. Spoon about 1 to 2 teaspoons of filling into each mushroom cap. Preheat Farberware Open Hearth® Broiler with rack in high position. Place stuffed mushrooms on rack with stuffing up. Broil 10 to 15 minutes.  
Makes 24 appetizers or use as a garnish for main dishes.

---

## RUMAKI

- 1/4 cup soy sauce
- 1/4 teaspoon ground ginger
- 1/4 teaspoon curry powder
- 3/4 pound chicken livers, cut in half
- 3/4 pound bacon slices, cut in half
- 1 can (8 oz) water chestnuts, drained and cut in half

Mix first three ingredients in a sturdy plastic bag. Add chicken livers and marinate in refrigerator at least 4 hours, turning occasionally. Preheat Open Hearth® Broiler with rack in high position. Wrap bacon strip around each liver and water chestnut; fasten with wooden pick. Broil about 25 minutes, turning frequently to brown on all sides.  
Makes about 30 appetizers

---

## PORT PLUM CHICKEN WINGS

- 1/2 cup port wine or grape juice
- 1/4 cup plum preserves
- 1/4 cup soy sauce
- 2 tablespoons lemon juice
- 2 pounds chicken wings

In a medium mixing bowl, combine all ingredients except wings. Add wings to mixture and marinate for 2 hours. Preheat Farberware Open Hearth® Broiler with rack in high position. Add wings and baste with marinade. Broil about 25 to 30 minutes basting frequently with marinade until golden brown and richly glazed.  
Makes about 4 to 6 servings.

---

## SAVORY BEEF ROAST

- 1 (4½-5 pound) sirloin tip roast, tied
- 3 cloves garlic, cut into slivers
- 6 tablespoons butter or margarine, softened
- 1 package (7/8 oz) onion gravy mix
- 1 teaspoon dried parsley flakes
- 1 teaspoon dried thyme

Preheat Open Hearth® Broiler-Rotisserie. Make several slits in roast and insert garlic slivers. Combine butter, gravy mix, parsley and thyme to form a paste. Rub meat with paste mixture. Balance roast on spit and place as close to heating element as possible without touching it. Roast for 1½ to 1¾ hours (for medium-rare) or to 140°F on meat thermometer.  
Makes 8 to 10 servings.

---

## TERIYAKI STEAK

- ¼ cup soy sauce
- ¼ cup dry sherry
- 2 tablespoons brown sugar
- 1 tablespoon vegetable oil
- 2 cloves garlic, minced
- ¼ teaspoon ginger
- ¼ teaspoon pepper
- 1 (2 pound) flank steak

In a bowl, combine all ingredients except flank steak. Mix thoroughly. Pour mixture into a shallow pan. Add flank steak. Turn to coat meat with marinade. Cover meat and refrigerate overnight. Preheat Farberware Open Hearth® Broiler with a rack in low position. Remove flank steak from marinade. Discard marinade. Add meat to rack. Broil 7 to 10 minutes each side for rare, 12 to 14 minutes for medium, 15 to 17 minutes for well done.  
Makes 4 servings.

---

## BEEF ROAST WESTERN-STYLE

- 1 (3 to 4 pound) rump roast, boned and tied
- 1 large onion, chopped
- 2 cups beer
- ⅛ teaspoon ginger

In a deep bowl, place roast. Combine remaining ingredients. Pour marinade over roast. Cover and refrigerate overnight. Remove roast from marinade. Preheat Farberware Open Hearth® Broiler-Rotisserie. Balance roast on spit. Place spit on spit supports so that roast is as close as possible to heating element without touching it. Attach motor and turn ON. Cook 1½ hours for rare, 1¾ hours for medium and 2 hours for well done.  
Makes 4 to 5 servings.

---

## STEAK CONTINENTAL

- 1 (1½ to 2 pound) london broil
- ¼ cup soy sauce
- ¼ cup water
- 2 tablespoons oil
- 1 small tomato, finely chopped
- 1 teaspoon oregano
- ¾ teaspoon pepper
- ½ teaspoon salt
- ¼ teaspoon garlic powder

On one side of meat, cut several diagonal ½-inch deep slashes across surface. Mix together remaining ingredients in a shallow pan. Add meat; turn to coat. Cover steak and refrigerate overnight. Preheat Farberware Open Hearth® Broiler with rack in low position. Remove meat from pan; discard marinade. Place meat on rack. Broil 15 minutes per side for rare, 17 minutes per side for medium and 20 minutes per side for well done. To serve cut in thin slices.

Makes 4 to 6 servings.

---

## PEPPERED RIB EYE ROAST

- 1 tablespoon crushed peppercorns
- 1 teaspoon dried thyme leaves
- 1 (4 to 4½ pound) rib eye roast

Combine peppercorns and thyme. Rub mixture over roast. Cover roast with aluminum foil and refrigerate 2 hours. Preheat Farberware Open Hearth® Broiler-Rotisserie. Balance roast on spit. Place spit on spit supports. Adjust spit so that roast is as close as possible to heating element without touching it. Attach motor and turn ON. Cook roast about 1½ hours for rare, 1¾ hours for medium, 2 hours for well done.

Makes 4 to 6 servings.

---

## DANISH MEAT PATTIES

- 4 slices bread, crusts removed and crumbled
- ¼ cup milk
- 1 pound ground beef
- ½ pound ground pork
- ¼ cup finely minced onion
- 2 tablespoons chopped fresh parsley
- 1 teaspoon salt
- dash black pepper

In a bowl, soak bread crumbs in milk for 10 minutes to soften. Add remaining ingredients and mix well. Shape into 6 patties. Preheat Farberware Open Hearth® Broiler with rack in low position. Cook patties 10 minutes each side or until meat loses its pinkness.

Makes 6 servings.

---

## ORIENTAL SPARERIBS

- 1/2 cup dry sherry
- 1/2 cup Hoisin sauce
- 1/4 soy sauce
- 4 cloves garlic, minced
- 2 tablespoons sugar
- 1/2 teaspoon grated gingerroot or 1/4 teaspoon ground ginger
- 2 1/2 to 3 pounds pork spareribs

In a bowl mix all ingredients except spareribs. Pour marinade into a shallow pan. Add spareribs; turn spareribs to coat. Cover spareribs and refrigerate overnight. Preheat Farberware Open Hearth® Broiler with rack in high position. Add ribs and broil about 15-20 minutes on each side. To serve, cut spareribs into individual portions. Makes 4 to 6 servings.

---

## STUFFED PORK CHOPS

- 4 pork chops, 1 1/2 to 2 inches thick
- 1/2 pound bulk sausage
- 1/4 cup butter or margarine
- 2 apples, peeled, cored and chopped coarsely
- 1/2 cup chopped celery
- 1/4 cup chopped almonds or walnuts
- 1/2 teaspoon salt
- 1/4 teaspoon savory
- 1/4 teaspoon black pepper

With a sharp knife, beginning at the fat side cut each pork chop horizontally to the bone to form a pocket. In a small skillet, brown sausage until meat loses its pinkness. Remove sausage and set aside. Drain fat. In same skillet, melt butter, add apples and celery. Saute 4 to 5 minutes until soft. In a large bowl, combine sausage, apple-celery mixture, nuts, salt, savory and black pepper. Stuff equal portions of mixture into each pork chop. Secure openings with wooden picks. Preheat Farberware Open Hearth® Broiler with rack in low position. Add pork chops to rack and broil 40 to 45 minutes until pork is done, turning once. Makes 4 servings.

---

## SALT AND PEPPER PORK ROAST

- 2 tablespoons honey
- 1 tablespoon prepared mustard
- 1 (3 pound) boned and tied pork roast
- 1 tablespoon coarse salt
- 1 tablespoon crushed peppercorns

Mix honey and mustard together; brush on pork roast. Mix salt and peppercorns; roll meat in mixture. Preheat Farberware Open Hearth® Broiler-Rotisserie. Balance roast on spit. Place spit on spit supports. Adjust support so that pork roast is as close as possible to heating element without touching it. Attach motor and turn ON. Cook about 1 1/2 hours or until meat thermometer reads 170°F. Makes 6 servings.

---

## SHISH KEBAB

- 2 medium onions
- 3 green peppers
- 1 (4 to 5 pound) leg of lamb, boned and cubed
- 1 cup white wine
- ½ cup olive oil
- ¼ cup lemon juice
- 2 tablespoons Worcestershire sauce
- 2 cloves garlic, minced
- 3 bay leaves
- 1 teaspoon oregano
- salt, pepper
- 1 pint cherry tomatoes
- Hot cooked rice (optional)

Cut the onion into quarters and separate the layers. Cut the peppers into quarters and cut each quarter in half. Combine all ingredients except tomatoes in a shallow roasting pan; mix well so that meat is completely coated. Marinate in the refrigerator several hours. Before cooking, add tomatoes to marinade, mix well to coat with the marinade. Alternately thread the meat cubes, onions, peppers and tomatoes onto skewers. Preheat Farberware Open Hearth® Broiler with rack in high position. Lay the skewers on the rack. Broil 20 to 25 minutes, turning several times and basting with marinade. Serve the skewers over hot cooked rice if desired. Makes 6 to 8 servings.

---

## ROAST LEG OF LAMB

- 1 (4 pound) leg of lamb
- 2 tablespoons brown sugar
- 2 tablespoons sherry
- 1 tablespoon soy sauce

Preheat Farberware Open Hearth® Broiler-Rotisserie. Balance lamb on spit. Place spit on spit supports. Adjust supports so that lamb is as close as possible to heating element without touching it. Attach motor and turn ON. Roast lamb for 2½ hours or until meat thermometer reads 170°F. Combine brown sugar, sherry and soy sauce. Brush lamb with sherry mixture after first hour of cooking. Makes 4 to 6 servings.

---

## BARBEQUED VEAL ROAST

- 1 can (8 oz) tomato sauce
- ¾ cup dry white wine
- 2 tablespoons lemon juice
- 2 tablespoons vegetable oil
- 1 tablespoon finely chopped onion
- 2 cloves garlic, minced
- 1 bay leaf
- 1 teaspoon salt
- ½ teaspoon pepper
- 1 (4½ to 6 pound) veal roast, boned and rolled

In a saucepan combine all ingredients except veal roast. Cook on medium heat for 30 minutes, stirring occasionally. Preheat Farberware Open Hearth® Broiler-Rotisserie. Balance veal roast on spit. Place spit on spit supports. Adjust supports so that roast is as close to heating element as possible without touching it. Attach motor and turn ON. Roast about 2¼ to 2½ hours or to 170°F on a meat thermometer. Baste with barbecue sauce during last hour of cooking. Makes 6 to 8 servings.

---

## CITRUS DUCK

- Rind of 1 lime, cut into pieces
- Rind of 1 lemon, cut into pieces
- Rind of 1 orange, cut into pieces
- 1/4 cup orange liqueur
- 1 (4 to 6 pound) duckling, cleaned
- 1/2 teaspoon salt
- 1 onion, quartered
- 2 chicken bouillon cubes
- 1 cup boiling water
- 2 tablespoons orange juice concentrate, undiluted
- 2 tablespoons orange juice
- 1 tablespoon lemon juice
- 1 tablespoon lime juice
- 1/4 cup orange liqueur
- 1 tablespoon honey
- 2 teaspoons cornstarch

Soak citrus rinds in 1/4 cup orange liqueur for at least 30 minutes. Rub inside of duckling cavity with salt. Place citrus rinds and onion and some of liqueur into cavity. Preheat Farberware Open Hearth® Broiler-Rotisserie. Insert spit through duckling so duckling is balanced and securely held by the spit forks at either end. Securely tie legs together and neck to back and wings to body. Place spit on supports so duckling is as close to heating element as possible without touching. Attach motor and turn ON. Roast about 2 1/2 hours or until tender. In the meantime, mix remaining ingredients in a saucepan. Heat mixture over low heat until thickened. Brush duckling with mixture during last half hour of roasting. Heat extra sauce, serve with duckling. Makes 4 servings.

---

## DUCK ORIENTAL

- 1 (4-6 pound) duckling, quartered
- 1 tablespoon oil
- 1 green pepper, coarsely chopped
- 1 onion, coarsely chopped
- 2 cloves garlic, minced
- 1 can (20 oz) crushed pineapple
- 1 cup chicken bouillon
- 1/3 cup soy sauce
- 1/3 cup brown sugar
- 1/4 cup vinegar
- 2 tablespoons cornstarch
- 1/2 teaspoon ground ginger
- Hot cooked rice

Preheat Farberware Open Hearth® Broiler with rack in high position. Place duckling on rack and broil, turning occasionally for 75 to 85 minutes. In the meantime, add oil to 10 1/2-inch fry pan. Add green peppers, onion and garlic and sauté over low heat until tender. Add remaining ingredients to fry pan and cook, stirring occasionally until thickened. Use this mixture to baste duckling quarters during last 20 to 30 minutes of cooking time. Serve duck over rice with extra sauce. Makes 4 servings.

---

## ROAST TURKEY WITH HERB STUFFING

- 1 (10 to 12 pound) turkey
- 1 teaspoon salt
- 1/2 teaspoon pepper
- 1 package (8 oz) herb stuffing cubes
- 2 cups milk, chicken bouillon or water
- 1 can (4 oz) sliced mushrooms, drained
- 1 can (4 oz) white kernel corn, drained
- 1/2 cup coarsely chopped walnuts or pecans
- 2 cups chopped celery
- 1/2 cup butter or margarine, melted (optional)

Sprinkle inside cavity of turkey with salt and pepper. Set turkey aside. To make stuffing, in a bowl combine stuffing cubes and milk, bouillon or water. Let mixture stand about 15 minutes to soften. Add remaining ingredients except butter. Mix well. Fill body and neck cavities loosely with stuffing. Place any remaining turkey on spit. Tie legs and wings securely together. Place spit on spit supports. Adjust spit supports so that turkey is as close to heating element as possible without touching it. Attach motor and turn ON. Cook about 3 1/2 to 4 1/2 hours until done. Tests of doneness include when turkey is pierced, juices will run clear or meat thermometer registers 180°F to 185°F. Remove turkey from rotisserie. Place turkey on a platter and let stand 20 minutes before slicing.  
Makes 10 to 12 servings.

---

## SAVORY STUFFED CHICKEN BREASTS

- 1/2 cup water
- 2 1/2 tablespoons butter or margarine
- 1 1/2 cups herb seasoned stuffing cubes
- 1/3 cup coarsely chopped walnuts
- 1/4 cup finely chopped celery
- 1 teaspoon savory
- 1/2 teaspoon salt
- 1/4 teaspoon pepper
- 2 whole chicken breasts, skinned and boned
- 1/4 cup butter or margarine, melted

In a small saucepot over medium heat, bring water and 2 1/2 tablespoons of butter or margarine to a boil. Place stuffing in a medium bowl, pour water-butter mixture over stuffing. Mix well. Add nuts, celery, savory, salt and pepper. Divide stuffing evenly between both chicken breasts. Pat stuffing down. Roll breasts up jelly roll fashion. Tie chicken with string to hold in stuffing. Preheat Farberware Open Hearth® Broiler with rack in high position. Place chicken breasts on rack. Cook for 1 to 1 1/4 hours, basting frequently melted butter. To serve, cut crosswise into halves.  
Makes 4 servings.

---

## HOISIN CHICKEN

- 1/4 cup Hoisin sauce
- 1/4 cup chopped scallions
- 2 tablespoons dry sherry
- 2 tablespoons chicken broth
- 2 tablespoons soy sauce
- 1 (2 to 2 1/2 pound) broiler-fryer chicken, cut into parts

In a bowl, combine all ingredients except chicken. Preheat Farberware Open Hearth® Broiler with rack in high position. Place chicken on rack and baste with sauce. Broil chicken about 40 to 45 minutes, turning and basting with sauce occasionally.  
Makes 4 servings.

---

## BARBEQUED CHICKEN

- 1 tablespoon butter or margarine
- 2 tablespoons chopped onion
- 1 cup catsup
- 1/2 cup water
- 1/4 cup brown sugar
- 3 tablespoons white vinegar
- 2 tablespoons Worcestershire sauce
- 1 teaspoon dry mustard
- 1 (2 to 2 1/2 pound) broiler-fryer chicken, cut into parts

In a medium saucepan, melt butter. Add chopped onion and sauté about 2 minutes. Add remaining ingredients except chicken. Simmer, uncovered for 20 minutes. Preheat Farberware Open Hearth® Broiler with rack in high position. Place chicken on rack. Baste with some barbeque sauce. Broil chicken, turning often 45-50 minutes. Baste frequently with barbeque sauce.  
Makes 4 servings.

---

## CORNISH HENS WITH WILD RICE STUFFING

- 1 package (6 oz) long grain wild rice mix
- 1/2 cup vegetable or olive oil
- 1/4 cup lemon juice
- 1 teaspoon oregano
- 1/4 teaspoon marjoram
- 1/4 teaspoon dried onion flakes
- 1/4 teaspoon paprika
- 2 (1 1/2 to 2 pounds) cornish game hens

Prepare wild rice mix according to package directions. Set aside. Combine remaining ingredients except cornish hens in a blender. Blend 30 seconds. Stuff hen cavities with rice. Balance hen on spit. Tie legs and wings securely together. Place spit on spit supports; adjust supports so that hens are as close to heating element as possible without touching it. Attach motor and turn ON. Baste hen with lemon sauce. Cook about 1 1/4 to 1 1/2 hours basting periodically with lemon sauce.  
Makes 2 servings.

---

## GRILLED TROUT

- 4 whole dressed rainbow or brook trout
- 1 cup Italian salad dressing
- 2 tablespoons chopped parsley
- 1 tablespoon butter, melted

With a sharp knife, make 3 light slashes on each side of fish. Pour dressing into a shallow baking pan, stir in parsley. Place fish in dressing, turning over to coat fish with marinade. Cover and refrigerate for 3-4 hours turning twice. Remove fish from marinade. Preheat Farberware Open Hearth® Broiler with rack in high position. Brush rack with butter. Add trout to rack. Cook fish about 10-15 minutes basting frequently with marinade until fish flakes easily with a fork.

Makes 4 servings.

---

## DILLED SALMON STEAKS

- 4 salmon steaks (about 2 pounds)
- 1/2 cup finely minced fresh dill
- 1/4 cup prepared mustard
- 3 tablespoons cider vinegar
- 2 tablespoons vegetable oil
- 1 tablespoon sugar
- 1 tablespoon butter, melted

Place salmon steaks on a plate. Spread dill in cavity and around sides of salmon. Cover salmon and refrigerate at least 6 hours. In a bowl, combine remaining ingredients except butter. Preheat Farberware Open Hearth® Broiler with rack in high position. Brush rack with butter. Add salmon steaks to rack. Baste with some of the mustard mixture. Cook about 10-15 minutes per side basting periodically with mustard mixture.

Makes 4 servings.

---

## FISH WITH VERMOUTH SAUCE

- 2 tablespoons butter or margarine
- 4 scallions, thinly sliced
- 1 1/2 tablespoons all-purpose flour
- 1/2 cup dry vermouth
- 1 cup milk
- 1 egg yolk
- 1/4 teaspoon salt
- 1 1/4 pound fish fillets or fish steaks

In a small saucepan melt butter over low heat. Add scallions and cook until tender. Add flour to butter and continue to cook until smooth, stirring constantly. Mix together vermouth, milk, egg yolk and salt; add to flour mixture. Cook over low heat until thickened, stirring constantly. Keep warm. Preheat Open Hearth® Broiler with greased rack in high position. Place fish on rack; broil (10 to 12 minutes for fish fillets or 30 to 34 minutes for fish steaks or until fish flakes easily with fork), turning once using a spatula. Serve fish with sauce.

Makes 4 servings.

---

## SHRIMP EN BROCHETTE

- 5 tablespoons olive oil
- 5 cloves garlic, minced
- 3 tablespoons lemon juice
- 2 tablespoons minced shallot or scallion
- 2 tablespoons chopped parsley
- 1/2 teaspoon black pepper
- 16 large raw, peeled and deveined shrimp\*

In a bowl combine first 6 ingredients. Add shrimp to mixture and marinate for 1 hour. Thread shrimp onto skewers. Preheat Farberware Open Hearth® Broiler with rack in high position. Add skewers to rack. Cook about 18-20 minutes turning and basting with marinade during cooking. Makes 4 servings.

\*If using frozen shrimp, thaw and drain completely. You may substitute small or medium sized shrimp or 1 lb scallops for large shrimp. Reduce cooking time to 13-15 minutes.

---

## FRUIT KEBABS

- 1/4 cup butter or margarine, melted
- 1/4 brown sugar
- 1 tablespoon lemon juice
- 1/4 teaspoon cinnamon
- 1 pineapple, cubed
- 1 pint strawberries, cleaned and hulled
- 2 pears, pared and cubed
- 2 apples, pared and cubed
- Grapes
- Fruit Dip

In a small saucepan combine butter, brown sugar, lemon juice and cinnamon. Bring to a boil over low heat, stirring constantly. Remove from heat. Preheat Open Hearth® Broiler-Rotisserie with rack on high position. Thread fruit cubes on skewers. Brush with brown sugar mixture. Broil, turning often, for 20 to 30 minutes or until fruit is tender. Brush often with brown sugar mixture. Serve with Fruit Dip, if desired. Makes 5 servings.

---

## FRUIT DIP

- 1 pint sour cream
- 2 tablespoons orange marmalade
- 2 tablespoons brown sugar

In a small mixing bowl combine all ingredients. Chill. Serve with Fruit Kebabs. Makes 1 cup fruit dip.

---

---

## FULL ONE-YEAR WARRANTY

FARBERWARE promises to the owner to repair, or at FARBERWARE option, to replace any part of this product, if proven to be defective in workmanship or material under normal use for a period of one year from date of purchase.

During this one year FARBERWARE will provide all labor and parts necessary to correct such defects free of charge, if the product has been used and operated in accordance with written instructions furnished with the product.

Delivery of the product to FARBERWARE, or its authorized Service Station, is the responsibility of the owner.

### EXCLUSIONS

1. Warranty does not cover accident, misuse, abuse or neglect on the part of the owner, and is void if product is taken apart or tampered with.
2. Warranty is invalid if the product has been serviced by an unauthorized Service Station.

### GENERAL

For your own safety and convenience always obtain service through an authorized Service Station. If service cannot be obtained, please call or write giving model number and/or type of part needed to:

FARBERWARE  
1500 BASSETT AVENUE, BRONX, NEW YORK 10461-2395  
TELEPHONE: 212-863-8000  
ATT: SERVICE DEPARTMENT

This warranty gives you specific legal rights, and you may also have other rights which vary from state to state.

NO RETURN CARD IS NECESSARY UNDER THIS WARRANTY.

**FARBERWARE®**  
THE PRODUCT  
OF A GOOD HOME™  
Subsidiary of Kidde, Inc.  
**KIDDE**

P-15-288  
PRINTED IN JAPAN