

Breadman Plus

INSTRUCTION MANUAL

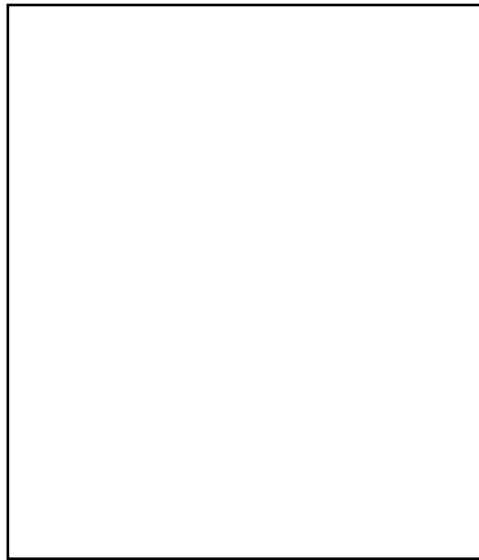

AUTOMATIC BREAD BAKER



TABLE OF CONTENTS

Important Safeguards	1
Your Breadman® Plus	2
Control Panel	3 - 4
Using the Breadman® Plus	5 - 7
Kneading and Baking Cycles	8
Super Rapid Breads, As Easy As 1-2-3!	9
Super Rapid Bread Recipes	10 - 13
Making Dough and Baking Bread	14 - 19
Using the 18-Hour Delay Bake Timer	20 - 21
Using the Pause Button	22
Using the Batter Bread™/Cake Cycle	23
Jam Cycle Instructions	24
Cleaning Instructions	25
Standard Bread Recipes	26
Cake Recipes	27 - 31
Jam Recipes	32
Pasta Dough Recipe	33
Trouble-Shooting	34 - 36
Guarantee/Warranty	Inside Back Cover



IMPORTANT SAFEGUARDS

When using the Breadman® Automatic Bread Baker, basic safety precautions should always be followed, particularly the following:

1. **READ ALL INSTRUCTIONS BEFORE USE.**
2. Do not touch hot surfaces. Use handles or knobs. Always use oven mitts when handling hot materials and allow metal parts to cool before cleaning.
3. Unplug this product from wall outlet when not in use and before cleaning. Allow to cool thoroughly before putting on or taking off parts.
4. Do not immerse appliance in water or any other liquid.
5. Close supervision is always necessary when this or any appliance is used by or near children.
6. Do not allow anything to rest on the power cord. Do not plug in cord where persons may walk or trip on it.
7. Do not operate this or any appliance with a frayed or damaged cord, or after the appliance malfunctions, or has been damaged in any manner. Return the appliance to Salton, Inc. Repair Dept. for examination and repair.
8. Avoid contact with any moving parts.
9. Do not use attachments not recommended by Salton, Inc.; they may damage the appliance or cause injury.
10. This appliance is intended for household use only. Do not use outdoors or for commercial purposes.

11. Do not let the cord hang over the edge of a table or counter, or touch hot surfaces. Do not place on an unsteady or cloth-covered surface.
12. Do not place the appliance near a hot gas or electric burner, in a heated oven or in a microwave.
13. Keep the unit at least 2 inches away from walls or any other objects when using it.
14. To disconnect, grip the plug and pull the plug from the wall outlet. Never pull on the cord.

SAVE THESE INSTRUCTIONS

Note:

- A. A short power-supply cord is provided to reduce the risk of becoming entangled in or tripping over a longer cord.
- B. If an extension cord is used:
 - (1) the marked electrical rating of the extension cord should be at least as great as the electrical rating of the appliance, and
 - (2) the cord should be arranged so that it will not drape over the counter top or tabletop where it can be pulled on by children or tripped over unintentionally.

CAUTION: During use, the internal parts of the Breadman® and the area around the Steam Vent are **HOT. Keep out of reach of children to avoid possible injury.**

FOR HOUSEHOLD USE ONLY



YOUR BREADMAN® PLUS

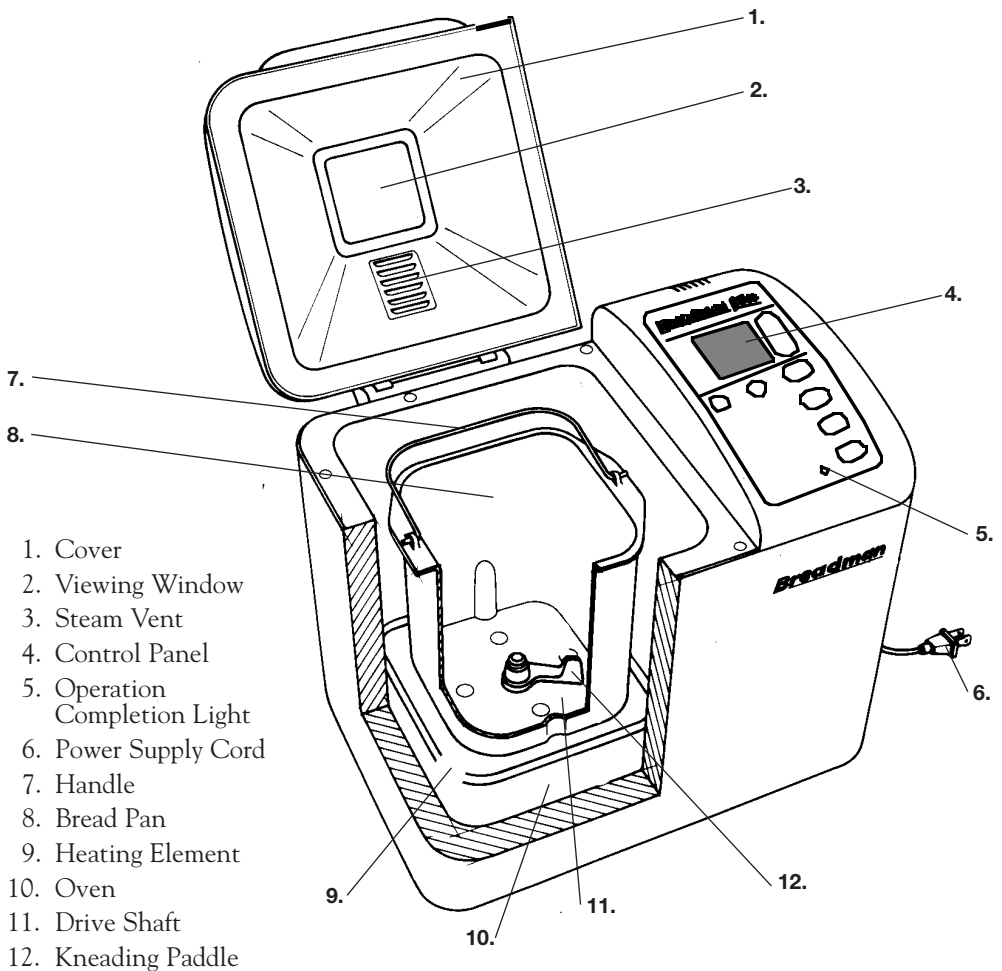

POLARIZED PLUG

This appliance has a polarized plug (one blade is wider than the other). To reduce the risk of electric shock, this plug is intended to fit into a polarized outlet only one way. If the plug does not fit fully in the outlet, reverse the plug. If it still does not fit, contact a qualified electrician. Do not attempt to modify the plug in any way.



CONTROL PANEL

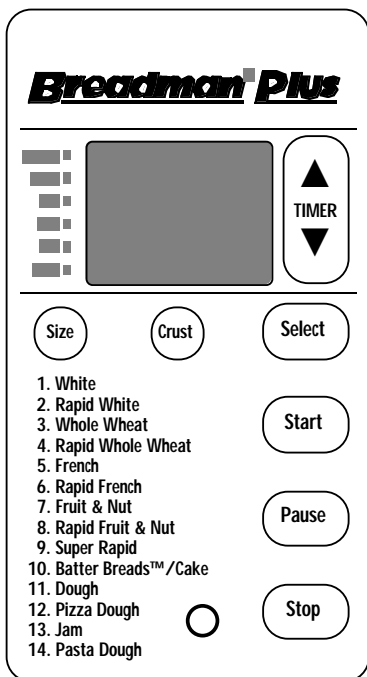

A. Display Window

Shows your Selection and Timer setting. You may also keep track of where you are in the bread making process by looking at the specific Cycles lined up on the left side of the Window.

B. Select

Press this button to select the Baking Cycle you want. Each time this button is pressed, the selection number will be displayed in the Display Window.

Select from these Cycles:

1. White
2. Rapid White
3. Whole Wheat
4. Rapid Whole Wheat
5. French
6. Rapid French
7. Fruit & Nut
8. Rapid Fruit & Nut
9. **Super** Rapid
10. Batter Bread™/Cake
11. Dough
12. Pizza Dough
13. Jam
14. Pasta Dough

C. Size

Press this button to select what size loaf you would like to bake. Sizes range from 1, 1-1/2 to 2 lb. loaves.

D. Crust

Press this button to select the brownness of the crust. You may choose from medium, dark or light.



CONTROL PANEL *(continued)*

E. Timer

Use this button to add or subtract time displayed in the Display Window.

▲ Each time you press this arrow, the Timer advances 10 minutes.

▼ Each time you press this arrow, the Timer is set back 10 minutes.

(Hint: Holding the arrow down in place will either fast forward ▲, or fast reverse ▼ the time.)

F. Start

Press this button to select the Baking Cycle you have chosen and to start the Timer.

G. Stop

Press this button for a full second to reset the Baking Cycle or Timer setting, or to stop baking.

H. Pause

The **PAUSE** function can be activated only after the machine has started a program. For more details, refer to the **PAUSE** Section in this manual.

*Note: When you press the **SELECT, SIZE, CRUST, TIMER, START, PAUSE** and **STOP** Buttons, you will hear a beep. This lets you know that your selection has been made.*

*If neither the **SIZE** nor the **CRUST** Button is pressed, this Breadman® Plus will set to a medium crust, 2 lb. loaf. This is an automatic default setting.*

I. Operation/Completion Indicator Light

When this Breadman® Plus is in operation, the Operation/Completion Indicator Light illuminates. When the Baking Cycle is completed and the Breadman® Plus goes into the Keep Warm Cycle, the Operation/Completion Light blinks. After 60 minutes, the blinking light will turn off.



USING THE BREADMAN® PLUS

With your new Breadman® Plus Automatic Bread Baker:

- You can use commonly available pre-packaged bread mixes. Follow the instructions on the package.
- You can bake a loaf of bread from scratch. See the *Recipe and Menu Planner* included with your Breadman® for lots of tasty options.
- You can make dough for rolls or loaves you'll bake in a standard oven. Use the Breadman's® Dough Cycles to do the mixing and kneading for you, then shape and bake the bread yourself.
- You can activate **PAUSE**, remove the dough for shaping, filling, braiding and more.
- You can activate **PAUSE** to score the top of your loaf for a rustic style bread or make a decorative crust with rolled oats, poppy seeds, etc.
- You can make non-yeast Batter Breads™, cakes & jam, pasta dough and pizza dough, too!
- You have 60 minute power failure back-up. If the electricity in your home goes out, this Breadman® Plus' memory stores the active program for up to 60 minutes. If power is re-connected within that time period, this Breadman® Plus will return to where it left off in the program cycle.
- If your power is out for longer than 60 minutes, and if you are using any dairy products, perishables or meats in your bread, for health, sanitary and other considerations, you should discard the contents of the recipe and start again with new fresh ingredients.



USING THE BREADMAN® PLUS *(continued)*

Inserting and Removing the Bread Pan

- To insert the Bread Pan in the Bread Baker, seat it in place and press down until it snaps into the side brackets.

Remember to insert the Kneading Paddle first, then add all your ingredients **BEFORE** inserting the Bread Pan into the Oven of your Breadman®.

- To remove the Bread Pan from the Oven, hold the Handle with a mitt and lift gently.

When you remove the Bread Pan after baking, **BE SURE TO WEAR OVEN MITTS** to prevent burning. After you remove the loaf by turning the Bread Pan upside down and shaking gently, check to see that the Kneading Paddle is removed from the loaf. If it is stuck in your bread, use a non-metal utensil to gently remove it, taking care not to scratch the Kneading Paddle.

Operating Tips

- Use oven mitts when working with bread or any part of the Breadman® that is hot from baking.
- Wipe off crumbs and clean the Breadman®, as needed, after baking.
- Unplug the Breadman® when you are not using it.
- **It is normal for the Viewing Window to collect moisture during the Rise Cycle.** As your bread bakes, the moisture will evaporate soon so you can watch your bread's baking progress.
- **Don't open the Lid excessively during baking.** This causes the bread to bake improperly.
- **Don't unplug the Breadman® during Kneading or Baking.** This will stop the operation.

Caution

- To protect young children, keep the Breadman® out of their reach when you're not there to supervise — especially during the Kneading and Baking Cycles.



USING THE BREADMAN® PLUS *(continued)*

- Use the Breadman® on a flat, hard surface. Don't place it near a flame or heat, or on a soft surface (such as a carpet or kitchen towel). Avoid placing it where it may tip over during use. Dropping the Breadman® could cause it to malfunction.
- To avoid burns, stay clear of the Steam Vent during kneading and baking. Also, don't touch the Viewing Window — it gets very hot.
- After baking, wait for the Breadman® to cool down before touching or cleaning the Bread Pan or internals of the Breadman® without oven mitts.
- Never use metal utensils with the Breadman®. These can scratch the non-stick surface of the Bread Pan.
- Avoid electric shock by unplugging before using a damp cloth or sponge to wipe the interior of the Oven.
- Never use the Bread Pan on a gas or electric cooktop or on an open flame.
- Avoid covering the Steam Vent during Kneading and Baking Cycles. This could cause the Breadman® to warp or discolor.
- Always make sure the Kneading Paddle is removed from the bread prior to slicing.



KNEADING AND BAKING CYCLES

The Breadman® Plus Automatic Bread Baker has many Baking Cycles from which you can choose, plus Dough Cycles and Jam.

- The **CRUST** Selection allows you to choose a Light, Medium and Dark Crust for most bread varieties, including Whole Wheat and White breads.
- The Whole Wheat Cycle is designed specifically for breads that contain Whole Wheat flours.
- The French Cycle is for breads with crisper crusts, especially those that are lowest in sweeteners, such as French and Italian breads.
- The Fruit & Nut Cycles are for breads such as Apple-Walnut or Raisin that have a higher sugar content.
- The Batter Bread™ Cycle is for non-yeast quick breads such as banana bread, pumpkin bread or cake.
- Fruit & Nut Add-In Beeper will occur in all cycles except #13 Jam. At this time, you may add fruits, nuts, herbs, etc. to your bread dough or pizza or pasta doughs.
- **NOTE: If bread is not removed immediately after baking, a controlled Keep Warm phase will begin for each selection (except Doughs and Jam).** While this will help reduce condensation between the loaf and Bread Pan, however, it is best to remove bread as soon as possible after completion of the Baking phase.
- **NOTE: Wheat Cycles have a rest period.** The Whole Wheat Cycle will rest for 30 minutes and the Whole Wheat Rapid Cycle will rest for 15 minutes, before any movement occurs in the Pan.



SUPER RAPID BREADS, AS EASY AS 1-2-3!

The Super Rapid Cycle, with hotter Rise and Bake temperatures, is convenient for baking a hot, fresh loaf of bread in under an hour! The longer bread programs, with lower rise and bake temperatures, will bake a taller, more developed loaf of bread.

1. Add ingredients to the Bread Pan in the order listed. Refer to Super Rapid Cycle Hints below for measuring information. Place the Bread Pan into the Bread Baker.
2. Close the Lid. Select the Super Rapid Cycle and press **START**.
3. When finished baking, remove Bread Pan from the Bread Baker. **BE SURE TO WEAR OVEN MITTS** to prevent burning. Invert and shake to remove the loaf. Allow the loaf to cool standing upright on a wire rack before slicing.

Super Rapid Cycle Hints

- Water temperatures must be 100°-115°F / 43°-46°C.
- Larger amounts of Quick-Rise,TM RapidRise,TM Bread Machine* yeast must be used. They may be substituted in equal amounts.
- The dough ball for the Super Rapid Cycle should be a very soft, sticky to the touch, loose ball with a smooth texture. Do not add extra flour.
- Check the dough ball, and if necessary, use a rubber spatula to push any flour or dough from the sides of the Bread Pan down into the dough ball.
- As a result of the increased temperatures during the rise and bake process, the loaf of bread produced from this program may have a dark, crisp crust with a split in the top of the loaf.

*These are special yeasts widely available in major grocery stores specifically for 59 minute super bake and super rapid bread



SUPER RAPID BREAD RECIPES

We suggest starting your Super Rapid bread baking with this White Bread Recipe. Refer to Super Rapid Cycle Hints for measuring information. Follow each step carefully, noticing the water temperatures must be 100°-115°F / 43°-46°C and that Quick-Rise,TM RapidRise,TM Bread Machine yeast must be used.

White Bread

	1 lb.	1.5 lb.	2 lb.
Water (100°-115°F/43°-46°C)	1 cup	1-1/4 cups	1-1/2 cups+3 TBL
Oil	4 tsp.	2-1/2 TBL	1/4 cup
Sugar	4 tsp.	2 TBL	3 TBL
Salt	1 tsp.	1-1/2 tsp.	2 tsp.
Dry Milk	1 TBL	1-1/2 TBL	2 TBL
Bread Flour	2-1/4 cups	3 cups	4 cups
Quick-Rise TM Yeast	3-1/2 tsp.	5-1/2 tsp.	6-3/4 tsp.
PROGRAM	9	9	9



SUPER RAPID BREAD RECIPES *(continued)*

Method

1. Remove the Bread Pan from the Bread Baker. Attach the Kneading Paddle onto the Shaft. Have all ingredients ready. Make sure all ingredients, except water, are at room temperature.
2. Use a liquid measuring cup to measure the water 100°-115°F / 43°-46°C and pour into the Bread Pan.
3. Use a measuring spoon to measure the oil and add to the Bread Pan.
4. Use a measuring spoon to measure the sugar, salt and dry milk; level off with the straight edge of a knife and add to the Bread Pan.
5. Lightly spoon bread flour into a dry measuring cup, level off with the straight edge of a knife and add to the Bread Pan.
6. Carefully measure Quick-Rise™ yeast with a measuring spoon; level off with the straight edge of a knife and add to the Bread Pan.
7. Place the Bread Pan into the Bread Baker. Push down on the Rim until it snaps into place. Close the Lid and plug in the Breadman®.
8. Select Super Rapid Cycle and press **START**.
9. At the beep during the Kneading Cycle, (:53), check the dough ball. It should be sticky to the touch. At this time, push down any dough or flour that may be on the sides of the Pan.
10. When the Beeper sounds, the bread has finished baking.
11. Use oven mitts to carefully remove the Bread Pan.

CAUTION: *The Oven Cavity, Bread Pan, Kneading Paddle and bread will be very hot. Use oven mitts.*

12. Turn Bread Pan upside down and shake several times to release the bread. Do not use metal utensils inside the Bread Pan or Bread Baker. Remove the Kneading Paddle and allow loaf to cool standing upright on wire rack approximately 20 minutes before cutting.
13. When the bread has completely cooled, approximately 2 hours, store in an airtight container.
14. Unplug unit before cleaning. Do not immerse the Bread Pan in water. See Cleaning Instructions.



SUPER RAPID BREAD RECIPES *(continued)*

White Wheat Bread

	1 lb.	2 lb.
Water (100°-115°F/43°-46°C)	3/4 cup + 3 TBL	1-1/2 cups + 3 TBL
Oil	1 TBL	3 TBL
Sugar	3 TBL	1/4 cup
Salt	1 tsp.	2 tsp.
Dry Milk	1 TBL	2 TBL
Bread Flour	1-3/4 cups	3-1/2 cups
Whole Wheat Flour	1/2 cup	1/2 cup
Quick-Rise™ Yeast	4-1/2 tsp.	6 tsp.
PROGRAM	9	9

French Bread

	1 lb.	2 lb.
Water (100°-115°F/43°-46°C)	3/4 cup + 3 TBL	1-1/2 cups + 2 TBL
Oil	1 TBL	3 TBL
Sugar	2-1/2 tsp.	1-1/2 TBL
Salt	3/4 tsp.	1-1/2 tsp.
Bread Flour	2-1/4 cups	4-1/3 cups
Quick-Rise™ Yeast	3-1/2 tsp.	6 tsp.
PROGRAM	9	9

Italian Bread

	1 lb.	2 lb.
Water (100°-115°F/43°-46°C)	1 cup + 1 TBL	1-1/2 cups + 1 TBL
Oil	4 tsp.	2 TBL
Sugar	2 TBL	1/4 cup
Salt	1 tsp.	2 tsp.
Dry Milk	1 TBL	2 TBL
Dried Italian Seasoning	1-1/2 tsp.	1 TBL
Bread Flour	2-1/4 cup	4 cups
Quick-Rise™ Yeast	4-1/2 tsp.	6-3/4 tsp.
PROGRAM	9	9



SUPER RAPID BREAD RECIPES *(continued)*

Honey Granola Bread

Water (100°-115°F/43°-46°C)	2 lb.
Oil	1-1/2 cups + 1 TBL
Honey	6 TBL
Salt	2-1/2 TBL
Dry Milk	2 tsp.
Bread Flour	3 TBL
Granola Cereal	4-1/4 cups
Quick-Rise™ Yeast	1 cup
PROGRAM	6-3/4 tsp.
	9

Cinnamon Raisin Bread

	1 lb.	2 lb.
Water (100°-115°F/43°-46°C)	1 cup + 1 TBL	1-1/4 cups + 1 TBL
Oil	1 TBL	7 tsp.
Brown Sugar	2-1/2 TBL	3-1/2 TBL
Salt	1 tsp.	1-1/2 tsp.
Dry Milk	1 TBL	1-1/2 TBL
Bread Flour	2-1/4 cups	3-1/2 cups
Cinnamon	3/4 tsp.	1 tsp.
Raisins	1/3 cup	1/2 cup
Walnuts	1/3 cup	1/2 cup
Quick-Rise™ Yeast	4-1/2 tsp.	6-3/4 tsp.
PROGRAM	9	9



MAKING DOUGH AND BAKING BREAD

Here's how to bake bread with your Breadman® Plus:

STEP 1

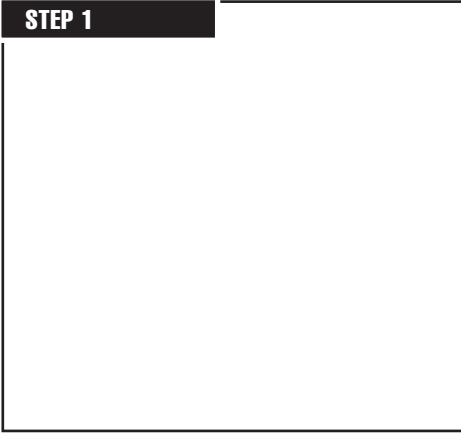

Open the Lid and remove the Bread Pan.

Lift the Bread Pan straight out of the machine.

STEP 2

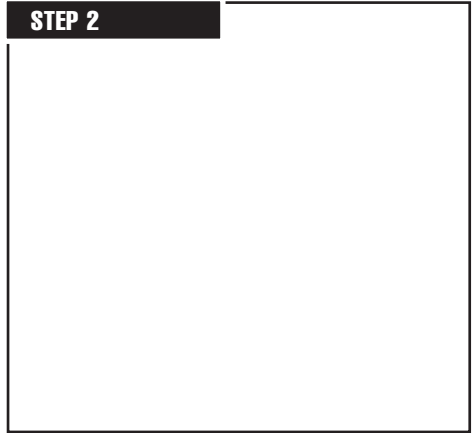

Position the Kneading Paddle on the Drive Shaft as shown.

Match the flat side of the Drive Shaft to the flat part of the hole in the Kneading Paddle. Make sure the paddle is secure.



MAKING DOUGH AND BAKING BREAD *(continued)*

STEP 3

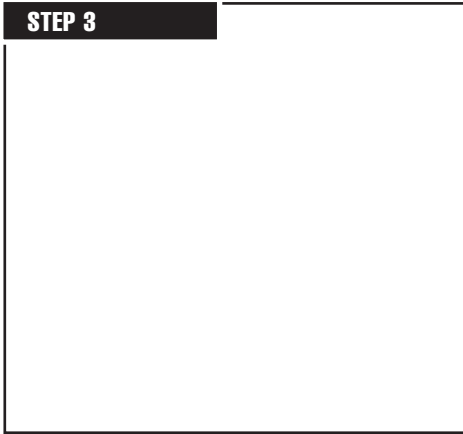

Place the ingredients into the Bread Pan.

For best results, add all liquid ingredients first. Then, beginning with the salt, add all dry ingredients EXCEPT yeast.

ALWAYS ADD YEAST LAST.

Note: If your recipe contains salt, please add it with the liquid ingredients, keeping it away from the yeast. Salt may interact with the yeast, reducing the ability of the bread to rise.

STEP 4

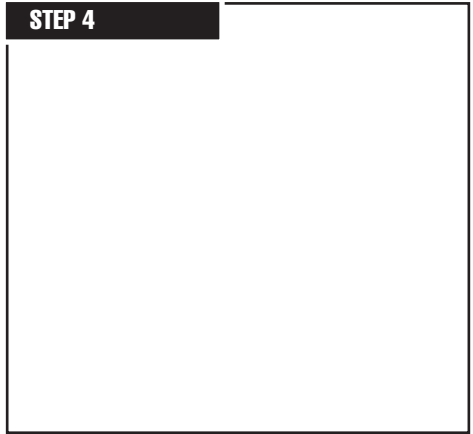

Make a small indentation on top of the dry ingredients (not so deep it reaches the wet layer) and add the yeast to the indentation.

This order of adding ingredients is important, especially when using the Timer, because it keeps the yeast away from the liquid ingredients until it's time to knead them together. (Liquid ingredients will prematurely activate the yeast.)



MAKING DOUGH AND BAKING BREAD *(continued)*

STEP 5

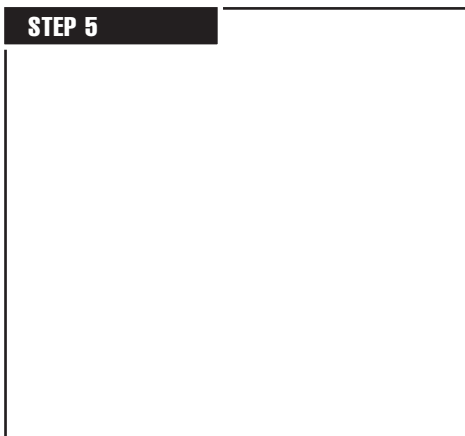

Insert the Bread Pan in the Breadman®

To insert the Bread Pan into the machine, set it in place. Press down until it snaps into place.

Close the Lid and plug in the Breadman®

When you first plug it in, this Breadman® Plus automatically sets to 000*.

*Does not apply during power failure back-up.

STEP 6

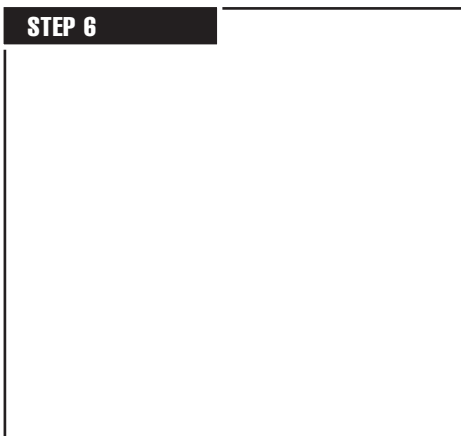

Press the SELECT button to choose the Cycle you want.

Press **SELECT** once to choose 1. White 2 lb. with medium crust. Each time you press **SELECT** again, the indicator moves onto the next option, in this order:

1. White
2. Rapid White
3. Whole Wheat
4. Rapid Whole Wheat
5. French
6. Rapid French
7. Fruit & Nut
8. Rapid Fruit & Nut
9. Super Rapid
10. Batter Bread™/Cake
11. Dough
12. Pizza Dough
13. Jam
14. Pasta Dough



MAKING DOUGH AND BAKING BREAD *(continued)*

STEP 7

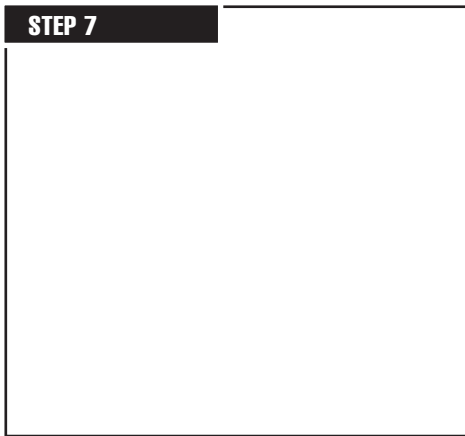

Press the **SIZE** Button to choose the size you want.

Press the **SIZE** Button to choose 2 lb., 1.5 lb., or 1 lb. size bread. Your selection will be shown in the Display Window.

*Loaf size can not be activated for:

- Batter Bread™/Cake
- Dough
- Pizza Dough
- Jam
- Pasta Dough

STEP 8



Press **CRUST** to choose light, medium or dark crust.

If this button is not pressed, the Breadman® Plus will automatically bake a loaf with a medium crust color.



MAKING DOUGH AND BAKING BREAD *(continued)*

STEP 9

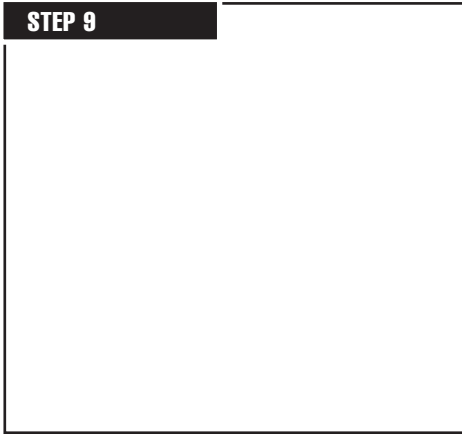

Press **START** to begin.

First, the Breadman® mixes the ingredients.* Then, it begins the Kneading process. During this process, the yeast begins to activate, and normally the Viewing Window begins to fog. (This will clear eventually.) The Breadman® will stop kneading after a few minutes to let the dough rise before baking.

If you chose Dough Cycle, the Breadman® beeps to let you know when the dough is ready to be removed. Then it's up to you to shape, proof and bake in a conventional oven.

For other cycles, Breadman® continues to the Baking process.

*Note: The Whole Wheat Cycles have a preliminary rest period.

STEP 10

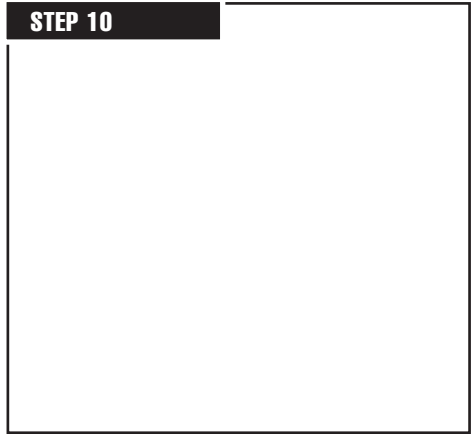

When your bread is done, the Breadman® will beep. This indicates that the Baking phase is completed. Put on your oven mitts and remove the Bread Pan.

Remember that the Bread Pan and your loaf are both very hot! Be careful not to place either on a tablecloth, plastic surface, or other surface that might scorch or melt.

If the bread is not removed immediately, a controlled Holding Keep Warm Cycle will begin and will automatically shut off after 60 min. While this will help prevent the bread from becoming soggy, **for best results**, remove bread immediately after Baking Cycle is complete.

The Keep Warm / Holding Cycle does not apply to Dough, Pasta Dough, Pizza Dough, Batter Bread™ / Cake or Jam Cycle.



MAKING DOUGH AND BAKING BREAD *(continued)*

STEP 11

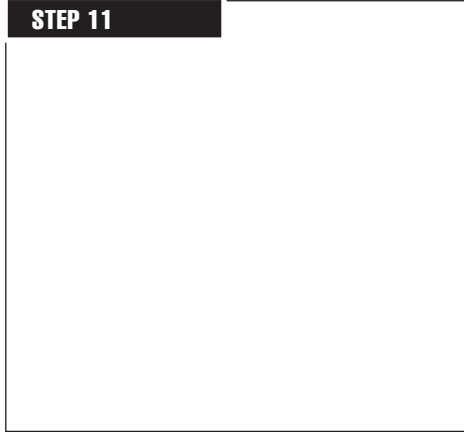

Remove the loaf from the Bread Pan.

Turn over the Bread Pan a few inches from the countertop and gently shake out the loaf. It's best to remove the loaf as soon as the Breadman[®] is done baking.

Place the loaf on a wire rack or other cooling surface to cool. Bread should be cooled (15 to 30 minutes) before it is sliced.

If necessary, remove the Kneading Paddle from the loaf.

Sometimes the Kneading Paddle will stick in a loaf of bread. If it does, use a non-metal utensil to gently remove it, taking care not to scratch the Kneading Paddle.

When you are done using the Breadman[®], be sure to unplug it.



USING THE 18-HOUR DELAY BAKE TIMER

You can pre-program your Breadman® Plus so that it bakes while you are at work or so that fresh bread is ready for you in the morning or the next day. Simply refer to the cycle charts for timing references.

Set ahead, delay baking does not apply to Jam or Pasta.

Note: *Don't use the Delay Bake Timer if your recipe includes eggs, fresh milk, or other dairy products, meats, fish, etc. that may spoil.*

To preset your Breadman®, follow these steps:

1. Add the ingredients as usual, taking care not to let the yeast and liquid ingredients contact one another.
2. If your recipe contains salt, please add salt with liquid ingredients, keeping it away from the yeast.
3. Close the Breadman® Lid and plug it in.
4. Select the Baking Cycle you want. The time needed for the selected Baking Cycle appears in the Display Window.
5. Press the ▲ Timer button once for each 10 minutes you want to add. (Use the ▼ button to subtract time from the Timer.) The amount of time you set is shown in the Display Window.
 - To fast forward time, continually press the ▲ button.
 - To fast reverse, continually press the ▼ button.
 - For example, if it is 8 o'clock AM and you want a loaf of bread ready at 1 o'clock PM, press the ▲ Timer button until the display reads 5:00, meaning it will finish baking in five hours. This is the hour difference between 8 o'clock AM and 1 o'clock PM.

Note: *Actual baking times will not change.*

6. Press **START** to begin the Timer. The colon (:) in the time displayed begins to flash, letting you know the Timer is started. When the Display Window indicates 0:00, baking is completed.
7. If you make an error after you've activated the Timer, and want to start over, press **STOP** and begin again.



THE 18-HOUR DELAY BAKE TIMER *(continued)*

For Best Results

- Take care to measure ingredients accurately, using a good set of measuring cups and spoons, or a good scale. Make sure to level all dry ingredients as you measure them. Inaccurate measuring could result in a loaf of bread you're not satisfied with.
- In particular, be precise in measuring the water.
- Use fresh ingredients.
 - Since moisture is an enemy to flour, be sure to store your flour in an airtight container.
 - To keep your yeast active, store it in an airtight container in your refrigerator.
 - **Do not use yeast if the date code on the packet has expired.**
- Speaking of fresh — when using the Timer, we recommend setting it for as short a time as possible. Because ingredients are partially combined in the Bread Pan, the dough may tend to deteriorate if left too many hours, especially on a warm or humid day.
- Keep the Lid closed during the Baking cycle. Opening it excessively causes uneven baking.
- After your bread has cooled completely, store it in a plastic bag or plastic wrap to prevent it from drying out.



USING THE PAUSE BUTTON

This Breadman® Plus has a vertical style loaf pan. This feature, in combination with the **PAUSE** button, lets you be very creative with bread machine baking.

When you press and hold **PAUSE** for a full 2 seconds, the Breadman® Plus will stay “on hold” for up to 10 minutes. You can press **PAUSE** at any time, during any cycle.

To activate the **PAUSE** mode, press and hold **PAUSE** for 2 seconds. You will hear a beep when the pause begins.

To resume the cycle, press **START** and the machine will start again at the point where it left off. If you forget to press **START**, the machine will automatically reactivate after 10 minutes have elapsed.

Using the **PAUSE** will let you do some of the following:

- Decorative crusts
- Braided breads
- Add crumble toppings
- Pull-apart rolls
- Monkey breads
- to coffee cakes
- Create rustic-style, Mediterranean-styled rolled bread.

Here’s a quick example of a rolled, Mediterranean-style bread using a French bread recipe:

Activate **PAUSE** at the end of the Knead 3 (see Kneading and Baking cycle Charts for time details).

Remove the dough. Roll it out on a clean, lightly floured surface. You’ll want to roll the dough into an 8-1/2” x 13” rectangle.

Lightly brush with good olive oil, such as *Tassos*. Then, sprinkle with fresh chopped garlic, basil, rosemary, and sun-dried tomatoes. Top with 1/3 cup of crumbled feta or goat cheese. If you would like, you could even add 2-3 slices of prosciutto.

You can remove the Kneading Paddle from the Pan and set it aside. It is no longer necessary for this recipe.

Roll the dough up tightly into an 8-1/2” wide roll. Tuck the ends under and place into the Bread Pan. Return the Bread Pan to the Breadmaker, close the Lid and press **START**.

The final rise will begin, immediately followed by **BAKE**.

As the baking begins, you could **PAUSE** again. You can score the top crust, gently mist the loaf with cold water, return the Bread Pan to the Oven, close the Lid and touch **START**. Your rustic, al fresco Mediterranean bread will soon finish baking.

Note: Do not leave the Lid standing open for extended periods of time. ALWAYS use an oven mitt when handling the pan and follow the Important Safeguards found in the beginning of this book.



USING THE BATTER BREAD™/CAKE CYCLE

The Breadman® Batter Bread™/Cake Cycle is for non-yeast breads, such as banana bread, pumpkin bread or cake. The Batter Breads usually call for quick-acting leavening agents such as baking powder or baking soda.

The Breadman® will mix all of the ingredients and bake a cake-like bread from 1 hour 25 minutes to 1 hour 45 minutes.

Note: These breads tend not to rise as high as yeast breads.

Basic cake recipes can be used as well as pre-packaged cake mixes.

For Best Results

When baking cakes from scratch, please note the following:

- **Baking cakes such as pound cake or angel food cake or any cake that requires long beating of eggs or egg whites or other ingredients are not recommended for this cycle.**
- If a recipe calls for a 9" x 5" cake pan, it will not have any problem fitting into the Baking Pan. On the same note, if a recipe is written to form two layers, the recipe can be cut in half to fit into the Baking Pan.
- **Cakes in which all ingredients can be mixed together at one time are prime recipes for the Breadman®.**

Operating Instructions For Batter Bread™/Cake Cycle

- Measure ingredients in the recipe and add to the Baking Pan. (Make sure the Kneading Paddle is in position.)
- Insert Baking Pan into the Breadman® and close the Lid.
- Press **SELECT** button to select the Batter Bread™/Cake function.
- Press **START** button to begin cycle.
- For Baking times, please refer to the Timing Charts.
- **BE SURE TO WEAR OVEN MITTS WHEN REMOVING FINISHED BREAD OR CAKE AS THE UNIT WILL BE VERY HOT!**
- Allow cake to cool down before removing it from the Pan.
- Turn onto a baking rack and let the cake cool completely before slicing or decorating.



JAM CYCLE INSTRUCTIONS

For Best Results

- Do not reduce sugar or use sugar substitutes. The exact amounts of sugar, fruit, and pectin are necessary for a good set.
- Use only ripe fruit (not overripe or underripe) for best flavor.
- Do not purée fruit. Crush with a potato masher or food processor. Jam should have bits of fruit in it.
- Recipes should not exceed 3 cups.
- Be sure to measure fruit after it has been crushed not before.
- Remove stems, seeds, or pits from fruit before crushing.

Operating Instructions

- With Kneading Paddle in position, add the crushed fruit to the Baking Pan.
- Add the rest of the called-for ingredients.
- Insert Baking Pan into the Breadman®.
- Close Lid.
- Press **SELECT** button until Jam Cycle is chosen.
- Press **START**.
- The Breadman® will pre-heat for 15 minutes before any movement occurs in the pan. After pre-heating, the jam will be heated and mixed for approximately 50 minutes. The entire cycle takes 1:25 in which 20 minutes is the cool-down cycle.
- The Breadman® will beep when the cycle is complete.
- Press **RESET** and remove the Pan, **MAKING SURE TO WEAR OVEN MITTS**.
- Pour the hot jam into a refrigerator/freezer-safe container, leaving 1/2" of space at the top.
- Cover tightly to store.
- Jam will thicken upon cooling and storage.



CLEANING INSTRUCTIONS

The Bread Pan and Kneading Paddle have non-stick surfaces that make cleaning easy.

1. After baking each loaf of bread, unplug the Breadman® and discard any crumbs.
2. Remove the Bread Pan from the Oven and the Kneading Paddle from the Bread Pan. Then, as needed, wash the Bread Pan and Kneading Paddle inside and out with warm, soapy water. Avoid scratching the non-stick surfaces. **DO NOT PUT THE PAN IN A DISHWASHER OR SOAK IT IN WATER.**

If the Kneading Paddle is stuck to the Drive Shaft, pour warm water in the Pan to loosen it.

DO NOT USE EXCESSIVE FORCE.

3. Wipe the inside of the Lid and Oven with a damp cloth or sponge. If any residue has scorched on the heating plate or elsewhere, scrub with a non-abrasive scrubbing pad and wipe clean.
 - Do not use vinegar, bleach, or harsh chemicals to clean the Breadman®.
 - Do not soak the Bread Pan for a long period of time — this could interfere with the free working of the Drive Shaft.
 - Be sure the Breadman® is completely cooled before storing.
 - The Inner Casing contains the heating element and drive base. Therefore, when cleaning, **NEVER pour water, solvents or cleaning solutions into this area.**

Caution

To avoid electric shock, unplug the Breadman® before cleaning!



STANDARD BREAD RECIPES

Basic White Bread

1.5 lb. Loaf

1 cup + 2 Tbsp. Water
2 Tbsp. Canola Oil
1-1/2 tsp. Salt
2 Tbsp. Sugar
1-1/2 Tbsp. Dry Milk Powder
3-1/4 cups White Bread Flour
1-3/4 tsp. Active Dry Yeast

2.0 lb. Loaf

1-1/4 cups + 2 Tbsp. Water
2 Tbsp. Canola Oil
2 tsp. Salt
3 Tbsp. Sugar
2 Tbsp. Dry Milk Powder
4-1/2 cups White Bread Flour
2 tsp. Active Dry Yeast

Whole Wheat Bread

1.5 lb. Loaf

1 cup + 2 Tbsp. Water
2 Tbsp. Oil
1-1/2 tsp. Salt
3 Tbsp. Brown Sugar
2 Tbsp. Dry Milk Powder
3-1/4 cups Whole Wheat
Bread Flour*
3-1/2 tsp. Active Dry Yeast

2.0 lb. Loaf

1-1/4 cups Water
3 Tbsp. Oil
2 tsp. Salt
4 Tbsp. Brown Sugar
3 Tbsp. Dry Milk Powder
4-1/3 cups Whole Wheat
Bread Flour*
4-1/2 tsp. Active Dry Yeast

*For best results, when not using Bread Flour, we recommend adding Gluten to the recipe. Add 1/2 cup of Gluten to a 2 lb. recipe.

Easy French Bread

1.5 lb. Loaf

1 cup + 2 Tbsp. Water
1 Tbsp. Olive Oil
1 tsp. Salt
1-1/4 Tbsp. Sugar
3-1/4 cups White Bread Flour
1-1/4 tsp. Active Dry Yeast

2.0 lb. Loaf

1-1/3 cup Water
2 Tbsp. Olive Oil
1-1/2 tsp. Salt
2 Tbsp. Sugar
4 cups White Bread Flour
1-1/2 tsp. Active Dry Yeast



CAKE RECIPES

Peanut Cake

1-1/2 cups	All Purpose Flour
1 tsp.	Baking Powder
3/4 tsp.	Baking Soda
1/4 tsp.	Salt
1/2 cup	White Sugar
2	Eggs, Large
1/2 cup	Lo-fat Yogurt
1/2 cup	Crunchy Peanut Butter, Softened
1/4 cup	Apple Sauce
1/4 cup	Water
1 tsp.	Vanilla Extract

Combine first four ingredients and mix well. Set aside.

Place eggs, yogurt, peanut butter, apple sauce, water, vanilla extract and sugar in the Baking Pan in that order. Close the Lid and start the Cake Cycle.

When continuous mixing begins, add the flour mixture in a slow, steady stream. Close the Lid.

Allow the cake to cool uncovered in the refrigerator for 25-30 minutes before attempting to remove it from the Pan.



CAKE RECIPES *(continued)*

Pineapple-Coconut Clafouti Cake

1-1/2 cups	All Purpose Flour
1 tsp.	Baking Powder
1/2 tsp.	Baking Soda
1/2 tsp.	Salt
3/4 cup	White Sugar
2	Eggs, Large
1/2 cup	Milk, Whole
1/2 cup	Canned Pineapple Chunks, Drained
1/4 cup	Pineapple Juice (from can)
1/2 cup	Sweetened Shredded Coconut
1 tsp.	Vanilla Extract

Combine first four ingredients and mix well. Set aside.

Place pineapple, pineapple juice, eggs, milk, coconut, sugar, and vanilla in the Baking Pan and place it in the machine. Close the Lid and start the Cake Cycle. When continuous mixing begins, add the flour mixture in a slow, steady stream. Close the Lid.

Allow the cake to cool uncovered in the refrigerator for 25-30 minutes before attempting to remove it from the Pan.



CAKE RECIPES *(continued)*

Devil's Food Pound Cake

1-1/2 cups	All Purpose Flour
1 cup	Cocoa Powder
1/4 tsp.	Nutmeg
1 tsp.	Baking Powder
3/4 tsp.	Baking Soda
1/2 tsp.	Salt
1 cup	White Sugar
1/2 cup	Lo-fat Yogurt, Plain
1/2 cup	Farmer's Cheese, Softened
1/2 cup	Semi-sweet Chocolate Chips
1	Egg, Large
1 oz. (shot glass)	Whiskey or Rum

In a small bowl, combine the first six ingredients and mix well. Set aside.

Place the egg, yogurt, cheese, whiskey, chocolate chips and sugar in the Baking Pan in that order. Place the pan in the machine and close the Lid. Start the Cake Cycle. When continuous mixing begins, add the flour mixture in a slow, steady stream. Close Lid.

Allow the cake to cool uncovered in the refrigerator for 25-30 minutes before attempting to remove it from the Baking Pan. Use a spatula to help loosen the cake if necessary.



CAKE RECIPES *(continued)*

Cinnamon-Raisin Coffee Cake

2 cups	All Purpose Flour
1 cup	White Sugar
1-1/4 cup	Milk, Whole
1/2 cup	Butter or Shortening, melted
2	Eggs, Large
2 Tbsp.	Dark Raisins
1 Tbsp.	Baking Powder
1 tsp.	Vanilla Extract
1/4 tsp.	Salt

Place milk, butter, eggs and vanilla extract in the Baking Pan. Add remaining ingredients and start the Cake Cycle.

Dust with powdered sugar after cake has cooled.

Lemon-Raisin “Cheezy” Cake

1-1/2 cups	All Purpose Flour
1 cup	Farmers Cheese (crumbled small)
1/4 cup	Lo-Fat Cream Cheese (cut in small pieces)
1/2 cup	White Sugar
2	Eggs, Large
1/3 cup	Water, Hot
2 Tbsp.	Golden Raisins, soaked
1 Tbsp.	Baking Powder
1 tsp.	Lemon Extract

Have all ingredients at room temperature (1-1/2 - 2 hrs.). Its very important that the cheeses are soft and in small pieces or they won't mix properly. Place cheese, egg, raisins, hot water, and lemon extract in Baking Pan. Add the remaining ingredients and start the Cake Cycle.

Makes about a 2 lb. cake.



CAKE RECIPES *(continued)*

Cranberry-Walnut Cake

1-1/2 cups	All Purpose Flour
1/3 cup	Chopped Walnuts
1/2 tsp.	Cinnamon
3/4 tsp.	Baking Powder
3/4 tsp.	Baking Soda
1/2 tsp.	Salt
1 cup	Fresh or Frozen Cranberries, Whole
1 cup	White Sugar
2	Eggs, Large
1/4 cup	Canola Oil
1 Tbsp.	Orange Juice
1/2 tsp.	Orange Extract
1 tsp.	Vanilla Extract

Crush the cranberries and mix with the sugar. Place in the Baking Pan and let stand for 10 minutes. Add the eggs, oil, orange juice and orange and vanilla extracts to the pan and place it in the machine. Close the Lid and start the Cake Cycle.

Combine the first six ingredients and mix well. When continuous mixing begins, add the flour mixture to the pan in a slow, steady stream. Close the Lid.

Allow the cake to cool uncovered in the refrigerator for 25-30 minutes before attempting to remove it from the Baking Pan.



JAM RECIPES

Blue Kiwi Mango Jam

3/4 cup (6 oz.)	Kiwi Fruit, Peeled and Chopped
3/4 cup (6 oz.)	Mango, Peeled and Chopped
1-1/2 cups (12 oz.)	White Sugar
1 tsp.	Lemon Zest, Grated
1 tsp.	Orange Zest, Grated
4 drops	Blue Food Coloring

Place all ingredients in Baking Pan and start the Jam Cycle.

The kiwi fruit should be ripe, but not mushy while the mango should be **barely ripe**. Lemon and orange zest are grated from the surface of the peel. Make sure none of the bitter white rind is included.

Peach-Raisin Jam

1-1/2 cups (12 oz.)	Ripe Peaches, Pitted
1-1/2 cups - 1 Tbsp.	White Sugar
2 Tbsp.	Golden Raisins, Soaked
1 Tbsp.	Brown Sugar
2	Whole Cloves
1/8 tsp.	Ground Allspice

Place all ingredients in Baking Pan and start the Jam Cycle.

For best results, fruit and sugar should be weighed on a small kitchen or postal scale. 1-1/2 cups of fruit or white sugar weighs 12 oz.



PASTA DOUGH RECIPE

Fresh Pasta Dough

2 cups	Flour
2	Eggs, Large (beaten)
1 tsp.	Salt
2 Tbsp.	Olive Oil
1/2 cup	Water or Juice

Place all ingredients in Bread Pan. Place Bread Pan into machine and select the Pasta Dough setting. Press **START**.



TROUBLE SHOOTING

Symptom	Possible Solutions
Bread has an offensive odor	Check to be sure you added the correct amount of yeast. Measure carefully — too much yeast will cause an unpleasant odor and may cause the loaf to rise too high. Be sure to use only fresh ingredients.
Baked bread is soggy or the bread's surface is sticky	Remove the bread from the Bread Pan as soon as it is done baking. Leaving it in the pan allows condensation to collect on the sides touching the pan. Also be sure to cool the loaf on a wire rack; cooling it on a countertop causes the side next to the counter to become soggy.
START button doesn't start the machine	Make sure the machine is plugged in. If nothing appears in the Display Window, press SELECT to choose your Baking Cycle. (You must select a Baking Cycle before pressing START.) If the baking area is too hot, the Breadman® will not start because of an automatic safety feature. Remove the Bread Pan with your ingredients, and wait until the Breadman® cools down — about 20 minutes — before starting a new loaf.
Can't set the Timer	Don't use the Timer if your recipe includes eggs, fresh milk or other ingredients that may spoil. This Timer cannot be used for the Jam Cycle. <i>Note: We recommend not using the Timer for the Dough, Rapid and Fruit & Nut or Pasta Dough Cycles.</i>



TROUBLE SHOOTING *(continued)*

Symptom	Possible Solutions
The Kneading Paddle was stuck in the bread	Make sure the Kneading Paddle is mounted properly before adding ingredients to the Bread Pan and baking. Sometimes denser or crustier loaves of bread may pull the Kneading Paddle out with them when you remove the loaves after baking. When this happens, use a non-metal utensil and gently remove the blade from the bottom of the loaf.
The bread rose too high	Make sure not to add too much yeast, water or flour. Too much of any of these may cause the loaf to rise more than it should.
The bread didn't rise enough	Did you add enough yeast, water or sweetener? Make sure to add ingredients in the proper order: liquids, dry ingredients, yeast. Make sure yeast doesn't get wet until the Breadman® mixes the ingredients together. Note: Typically, bread made with whole grain flours will not rise as high as bread made with refined flours.
The dough looks like batter, or the dough ball is still sticky, not smooth and round	During the Kneading process, add 1 tablespoon of flour at a time, letting it mix in well. For most breads, your dough ball should become round, smooth, not sticky to the touch, and should bounce back when you press it with your finger.
The dough ball is lumpy or too dry	During the Kneading process, add 1 tablespoon of water at a time, letting it mix in well.
The bread didn't rise at all	Make sure yeast is not left out. Also check the date code on the yeast and that it is always the last ingredient put into the pan. Make sure the yeast doesn't come into contact with salt or any liquid ingredients. For breads made with the Super Rapid Cycle, always use Quick-Rise™ yeast.



TROUBLE SHOOTING *(continued)*

Symptom	Possible Solutions
The bread is caved in	Make sure liquids are measured correctly. Next time, reduce your liquids by 2 tablespoons. If you're adding fruits or vegetables, make sure they are well drained.
“_ _ H” displays and beeps when you press START button	The Breadman® is too hot to begin preparing another loaf. Remove the Bread Pan with your ingredients, and wait until the Breadman® cools down — about 20 minutes — before preparing a new loaf.
“_ _ L” displays and beeps when you press START button	The Breadman® is too cold. Unplug the machine and allow it to heat up to room temperature, then try again.
“H:I” □□ □□ or □□ □□ displays and beeps when you press START button	Unplug the Breadman® Plus and contact Salton/MAXIM Service Department at 1-800-233-9054.

ONE-YEAR LIMITED WARRANTY

This Salton, Inc. product warranty extends to the original consumer purchaser of the product.

Warranty Duration: This product is warranted to the original consumer purchaser for a period of one (1) year from the original purchase date.

Warranty Coverage: This product is warranted against defective materials or workmanship. This warranty is void if the product has been damaged by accident, in shipment, unreasonable use, misuse, neglect, improper service, commercial use, repairs by unauthorized personnel or other causes not arising out of defects in materials or workmanship. This warranty is effective only if the product is purchased and operated in the USA, and does not extend to any units which have been used in violation of written instructions furnished by Salton, Inc., or to units which have been altered or modified or to damage to products or parts thereof which have had the serial number removed, altered, defaced or rendered illegible. Wear and tear for Bread Pans and Paddles is not considered a manufacturer's defect.

Warranty Disclaimers: This warranty is in lieu of all warranties expressed or implied and no representative or person is authorized to assume for Salton, Inc. any other liability in connection with the sale of our products. There shall be no claims for defects or failure of performance or product failure under any theory of tort, contract or commercial law including, but not limited to, negligence, gross negligence, strict liability, breach of warranty and breach of contract.

Warranty Performance: During the above one-year warranty period, a product with a defect will be either repaired or replaced with a reconditioned comparable model (at Salton, Inc.'s option) when the product is returned to the Salton, Inc.'s warranty period and an additional one-month period. No charge will be made for such repair or replacement.

Service and Repair

Should the appliance malfunction, you should first call toll-free 1-800-233-9054 **between the hours of 8:00 am and 5:00 pm Central Standard Time** and ask for CONSUMER SERVICE stating that you are a consumer with a problem.

In-Warranty Service: For an appliance covered under the warranty period, no charge is made for service or postage. Call for pre-paid return mailing label. (U.S. Customers Only)

Out-of-Warranty Service: A flat rate charge by model is made for out-of-warranty service. Include \$15.00 for return shipping and handling.

Salton, Inc. cannot assume responsibility for loss or damage during incoming shipment. For your protection, carefully package the product for shipment and insure it with the carrier. Be sure to enclose the following items with your appliance: any accessories related to your problem; your full return address and daytime phone number; a note describing the problem you experienced; a copy of your sales receipt or other proof of purchase to determine warranty status. C.O.D. shipments cannot be accepted.

Return the appliance to:

ATTN: Repair Department
Salton, Inc.
550 Business Center Drive
Mt. Prospect, Illinois 60056

For more information on Salton, Inc. products:

visit our website: <http://www.breadman.com> or E-mail us at breadman@saltonusa.com

IMPORTANT NOTICE

*If any parts are missing or defective,
DO NOT return this product.
Please call our Customer Service Department for assistance.*

800-233-9054 Monday - Friday 8am - 5pm CST

Thank You



If after reading this instruction
booklet you still have questions about using the
Breadman® Automatic Bread Machine,
please write or call:

Salton, Inc.
550 Business Center Drive
Mt. Prospect, IL 60056
1-800-233-9054

Monday - Friday 8am - 5pm CST

For more information on Salton, Inc. products, E-mail us at:

breadman@saltonusa.com

OR, visit our website:
<http://www.breadman.com>



HEALTHY

BREAD

1-2 pound

RECIPES

& menu planner

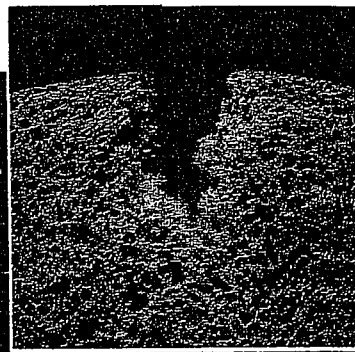



Contents

Introduction	1
Health Benefits of Whole Grain Breads.....	2
Recipe Ingredients	3
Bread Ingredients	4-5
Grain Glossary	6
Measuring and Measuring Equivalents	7
Sample Menus Using Whole Grain Breads.....	8

RECIPES

Basic White/French Bread	9
Egg Bread	9
Variation: Brioche (Rich White Bread)	9
Honey Banana Whole Wheat Bread	10
Light Whole Wheat Bread.....	10
Dark Rye (Pumpernickel) Bread	11
Light Caraway Rye Bread	11
Cinnamon Raisin Bread	12
Anadama Oatmeal Bread	12
Seven Grain Bread.....	13
Two Cheese Bread	13
Whole Wheat Zucchini Herb Bread	14
Yogurt Whole Wheat Bread	14
Sourdough Bread	15
The Breadman's World Famous, All-Natural, No-Butter Cinnamon Rolls	16
Pizza Dough	17



Introduction

Since biblical times, bread has been considered “the staff of life.” Today whole grains are still recognized as the foundation of a nutritious diet. The USDA’s Food Guide Pyramid, the new food guideline that replaces the old four food groups, recommends that whole grains comprise nearly 50 percent of our daily calories. According to these guidelines, we should eat six to eleven servings of whole grains every day.

This USDA recommendation is easy to follow with your Automatic Bread Baker. Specially designed to handle whole grains, the Breadmaker bakes up deliciously healthy nutrition with just the touch of a button. And you can guarantee that your family gets only the freshest, most health-giving breads because you are in control. You choose the flour, you select the sweetener (if any), and you decide when the baking process will start. Whenever you desire, you can have an aromatic loaf of just-baked bread, bursting with all the goodness of whole grains and containing no hidden additives, saturated fats, excess sodium or refined sugars.

Let this Recipe and Menu Planner be the beginning of your health-enhancing adventures with bread baking. The suggestions provided here are just that — suggestions. Please feel free to use your imagination and enjoy experimenting with your favorite ingredients.



Health Benefits of Whole Grain Breads

Refined grains, and the products made from them, have literally been stripped of their natural goodness. Commonly listed as white flour, wheat flour or even enriched flour, refined grains are almost devoid of the fiber and important nutrients that were intact in the original grain. Besides being processed, white flour is often bleached to achieve that snow-white appearance. All this adulteration has changed a wholesome food into a food fragment containing little nutritional benefit and very little character.

Fiber-rich whole grains and whole grain flours have been the focus of many scientific studies demonstrating that they reduce the risk of diverticulosis, colon and rectal cancer, and atherosclerosis. Diets containing adequate fiber inherently tend to be lower in fat and calories, especially saturated fat and cholesterol, which may contribute to the reduced risk factor.

Fiber is the primary reason that whole grain breads and other products are so satisfying to eat. Fiber is filling, and because it contains so few calories, it is an excellent part of the low-fat, high complex carbohydrate diet recommended for better health.



Recipe Ingredients

Bread recipes begin with a very basic set of ingredients: water, flour, salt and yeast. To this short list, you can add a variety of interesting and delicious ingredients that will give your breads the individuality you are looking for. Seeds, nuts, nut butters, dried fruits, raisins, dates, apples, berries, herbs, spices, carob powder, vegetables and bran are just a few of the many ingredients you can use to create hundreds of unique and flavorful breads.

Purchase fresh ingredients whenever possible for the best taste and results. Dried foods, such as fruits, vegetables, herbs and spices will keep for a virtually unlimited time if stored in a cool, dry environment. Store produce, oils, whole grain flours and other perishable foods in the refrigerator for longer life and retention of flavor. Glass and hard plastic containers with tight fitting lids are preferable for storing most foods; they keep the aromas in but do not expose the foods to the potentially harmful ingredients found in some plastic containers. Plastic may absorb strong odors, so for spicy or pungent ingredients, always use glass.

You will probably be able to find most, if not all, of the ingredients needed for baking healthy breads at your supermarket; consumer demand has helped many grocers become more health conscious. If some of the ingredients are not available yet in your grocery store, your health food store is certain to stock them.

For understanding how bread ingredients work, read the following section.



Bread Ingredients

The only ingredients needed to make bread are: flour, water and yeast — *the rest is personality*. Learn a little about what each of the other ingredients add and you will be prepared to create your own delicious recipes.

Flour

Bread Flour Bread Flour can be used when the recipe calls for bread or all purpose flour. It has more gluten than all purpose flour and is a better choice when mixing white flour with whole grain flours. Bread flour often has ascorbic acid (vitamin C) added as a dough conditioner. This creates a larger holed grain sought by many bakers.

All Purpose Flour This is fine whenever the recipe calls for all white flour. It will make a smaller grained bread than bread flour. All purpose flour and bread flour are wheat flours with the bran and germ removed and B vitamins added.

Gluten Gluten is a mixture of proteins responsible for the elastic (glue) quality of dough. As yeast grows, it releases bubbles of carbon dioxide that become trapped by the stretchy gluten. Wheat has a high gluten content while other grains have little or none. Use it in recipes that call for whole grain flours to prevent the top of the loaf from collapsing. Buy gluten in any health food store.

Whole Wheat Whole wheat flour adds a nutty flavor. It also increases the nutritional and fiber content of a recipe. It has less gluten than white flour, and used alone, will create a dense loaf. Many of our recipes use a mixture of whole wheat and bread flour to create a light textured, nutritious bread.

Other Whole Grains Rye, buckwheat, spelt, oats and other whole grains add wonderful flavors and nutrients to bread but do not have gluten needed to rise very high. Mix 3 to 4 parts of wheat flour for each part non-wheat (or add a few Tbls. of gluten) to make sure your dough will rise.

Eggs Eggs add color, richness, protein and structure to bread. They also serve as a liquid. A large egg adds about 3 Tbl. of liquid, and an extra large egg, 1/4 cup (4 Tbl.) When adding or eliminating eggs, adjust the other liquids in your recipe. All the recipes given here were made with large sized eggs.

Butter and Oil Fats add richness to bread and keep it fresher longer, which is why breads without any butter or oil are great fresh, but get stale very fast. They also add calories — about 100 calories per loaf for every tablespoon of added fat.



Bread Ingredients *(continued)*

Milk Adding milk creates a tender textured, mellower flavored bread. Yogurt, buttermilk, and sour cream make moist doughs, and add a slight tangy flavor. Milk also increases the protein content of bread. Fresh milk is fine when making recipes to start immediately. When setting the timer ahead several hours, use dry milk to prevent spoiling.

Yeast All the recipes here use dry active yeast — the small packages contain 1 Tbl. (1/4 oz.). If you bake often, however, it is convenient to buy yeast loose in jars and measure out only the amount you need. Check expiration date before buying or using and keep yeast refrigerated or in the freezer.

Salt Salt adds flavor to bread and tempers the rising process. If you are watching your salt intake, reduce the amount of added salt or leave it out completely. Dough, however, rises more quickly without salt, so add a bit less yeast as you reduce the salt.

Sweeteners Yeast does not need a sweetener to rise — flour serves as its food — but it speeds up the process. Sweeteners, of course, add flavor, and keep bread moist longer. Sugar adds pure sweetness, while brown sugar, honey, maple syrup and molasses also add distinctive flavors. Molasses, the strongest flavored sweetener, is sometimes used to darken recipes.



Grain Glossary

Amaranth This petite golden grain is moving quickly from the “unusual” grain category to one of the mainstream acceptance. A mainstay in the diet of the Aztecs, amaranth was considered a strength-giving food, probably due to its high protein profile. Both the grain and its flour offer a distinct flavor when added to your favorite bread recipes.

Barley This grain has a hearty, earthy flavor and produces a dense loaf of bread due to its low gluten content. Barley is a good substitute for white flour in recipes, but should be cut with a lighter flour when several cups are being used at a time.

Buckwheat Technically not a grain, buckwheat is really the fruit of a plant related to rhubarb. Its flour (ground buckwheat seed) and groats are both useful for unique bread baking. The flavor has been described as a combination of rosemary and green tea.

Corn The only grain eaten fresh as a vegetable, corn (also known as maize) is available in a wide variety of colors. Judge the freshness of cornmeal and flour from its sweet and delicate flavor. Blue cornmeal, a beautiful hue when dry, becomes a purplish color when cooked.

Kamut This “ancient” wheat grain is available as a whole grain, rolled grain, flour and cereal. People who are wheat sensitive have reported a tolerance to kamut products, though this is still being investigated.

Millet Commonly used to feed birds, millet lends a delightful crunch when added in whole grain form to recipes. People who are allergic to other grains have had luck with millet. It is considered to be the most digestible grain around.

Oat Rolled oats and oat flour are welcome additions to almost any bread recipe. Their delicately light texture and flavor embody the pleasures of home-baked goodness. Grind your own oat flour by chopping oat flakes in the blender until they reach the desired consistency.

Quinoa This recently rediscovered grain is found in whole form, in flour and in prepared products like pasta. When added to bread recipes, it imparts an earthy flavor matched by no other grain, and it packs a protein punch.

Rye This cold-weather grain is famous for its use in savory pumpernickel and caraway seed-rich rye breads. Rye has very little gluten and rises with the assistance of wheat flours.

Spelt Another of the “ancient” super grains, spelt has been reintroduced with resounding success. Use it in bread recipes in place of wheat for a slightly nutty flavor.

Wheat Wheat and whole wheat flour are the basis for most bread recipes. The gluten content of wheat provides the strength and resiliency necessary for a high and sturdy loaf.



Measuring

Measure all ingredients carefully. You will need two types of measuring cups, liquid and dry — it is very difficult to measure dry ingredients accurately with liquid measures.

Liquid measures: are either glass or clear plastic, graduated cups.

Dry measures: sell in sets of 5 nested cups (1/8, 1/4, 1/3, 1/2, and 1 cup) or 5 nested spoons (1/8, 1/4, 1/2, and 1 teaspoon, plus 1 Tablespoon).

Measuring Equivalents

	Dry	Liquid
1 cup	16 Tbl.	8 oz.
1/2 cup	8 Tbl.	4 oz.
1/3 cup	5 Tbl. & 1 tsp.	2.7 oz.
1/4 cup	4 Tbl.	2 oz.
1/8 cup	2 Tbl.	1 oz.
1 Tbl.	3 tsp.	1/2 oz.



Sample Menus Using Whole Grain Breads

Sample 1

Breakfast

Fresh orange-grapefruit juice
Slice Honey Banana Whole Wheat Bread
(page 10) toasted,
with 1 tablespoon peanut butter
Banana

Mid-Morning

Slice Anadama Oatmeal Bread (page 12)
with 1 tablespoon apple butter

Lunch

Sandwich with humus, celery,
sprouts, tomato, cucumber
on Yogurt Whole Wheat Bread
(page 14)

Afternoon Break

Fresh fruit or veggie sticks

Dinner

Baked potato with skin,
topped with salsa
Black bean and rice salad,
topped with chilies and tomatoes
Slice Dark Rye (Pumpernickel) Bread
(page 11)
Raw mixed vegetable salad

Evening Snack

Air-popped popcorn
or fresh fruit

Sample 2

Breakfast

Fresh pineapple juice
Slice Cinnamon Raisin Bread
(page 12), toasted
1/2 cup plain low or non-fat yogurt

Mid-Morning

Whole Wheat Zucchini Herb Bread (page 14)

Lunch

Wild greens salad with
rice vinegar dressing
Slice Light Caraway Rye Bread (page 11)
Minestrone soup
Steamed or stir-fried vegetables

Afternoon Break

Fresh tomato-cucumber-parsley
juice, with a dash of hot sauce
or lemon juice if desired

Dinner

Poached fish with lemon
Slice Seven Grain Bread (page 13)
Steamed asparagus and carrots
Fresh spinach salad

Evening Snack

Low-fat baked corn chips
with salsa

Note: These bread recommendations are suggestions only. Your favorite bread recipes may be substituted in any of the above meal plans.



Please Note: The following recipes were created using the "Basic Bread" setting.
Please Note - Salt and sugar should go in with water. Do Not put in with yeast.

RECIPES

Basic White/French Bread

Makes a 1-1/2 lb. loaf

1-1/8 cup warm water
1-1/2 Tbl. vegetable oil (optional)
3 cups all purpose flour
1-1/2 tsp. salt
2 tsp. active dry yeast

Add all ingredients to bread pan in the order given.

Makes a 2 lb. loaf

1-1/2 cup warm water
2 Tbl. vegetable oil (optional)
4 cups all purpose flour
1-1/2 tsp. salt
2-1/2 tsp. active dry yeast

Egg Bread

Makes a 1-1/2 lb. loaf

2/3 cup warm water
1-1/2 Tbl. vegetable oil
2 eggs
3 cups all purpose flour
2 tsp. sugar
1-1/2 tsp. yeast

Add all ingredients to bread pan in the order given.

Makes a 2 lb. loaf

1 cup warm water
2 Tbl. vegetable oil
2 eggs plus enough water to make 1/2 cup
4-1/4 cups all purpose flour
1 Tbl. sugar
2 tsp. yeast

Variation:

Brioche (Rich White Bread)

Use the egg bread recipe with the following substitutions:

- Replace the water with milk
- Increase the oil (or use butter) to 2 Tbl. for 1-1/2 lb. loaf, and 3 Tbl. for the 2 lb. loaf.
- Increase the sugar to 2 Tbl. for 1-1/2 lb. loaf, and 3 Tbl. for the 2 lb. loaf.



Honey Banana Whole Wheat Bread

This delicious loaf tastes like a sweet banana bread — only much healthier — and it makes a great peanut butter sandwich.

Makes a 1-1/2 lb. loaf

1/2 cup warm water
1 Tbl. butter or vegetable oil
3 Tbl. honey
1 egg
1/2 tsp. vanilla
1 cup whole wheat flour
1-1/4 cup bread flour
1 small banana, sliced
1-1/2 tsp. poppy seeds
1/2 tsp. salt
1-1/2 tsp. dry yeast

Add all ingredients to bread pan in the order given.

Makes a 2 lb. loaf

2/3 cup warm water
1-1/2 Tbl. butter or vegetable oil
1/4 cup honey
1 egg
1/2 tsp. vanilla
1-1/2 cup whole wheat flour
1-1/2 cup bread flour
1 banana, sliced
2 tsp. poppy seeds
1 tsp. salt
2 tsp. dry yeast

Light Whole Wheat Bread

Makes a 1-1/2 lb. loaf

1-1/4 cup warm water
1 Tbl. vegetable oil
2 Tbl. honey
3/4 cup whole wheat flour
3/4 cup whole wheat pastry flour
1 cup bread flour
1/4 cup gluten
1/2 tsp. salt
1-1/2 tsp. dry yeast

Add all ingredients to bread pan in the order given.

Makes a 2 lb. loaf

1-1/2 cup warm water
1 Tbl. vegetable oil
3 Tbl. honey
1 cup whole wheat flour
1-1/4 cup whole wheat pastry flour
1-1/4 cup bread flour
1/3 cup gluten
1/2 tsp. salt
2 tsp. dry yeast



Dark Rye (Pumpernickel) Bread

Pumpernickel makes the best deli, cheese or vegetable sandwich. If you want an even darker colored bread, increase the amount of cocoa or add a teaspoon of instant espresso.

Makes a 1-1/2 lb. loaf

1-1/4 cup warm water
1 Tbl. vegetable oil
1-1/2 Tbl. molasses
1 cup rye flour
1-1/2 cup bread flour
1/2 cup whole wheat flour
1/4 cup gluten
3 Tbl. dry milk powder
1 Tbl. caraway seeds
1 Tbl. cocoa
1 tsp. salt
1-1/2 tsp. dry yeast

Add all ingredients to bread pan in the order given.

Makes a 2 lb. loaf

1-1/2 cup warm water
1-1/2 Tbl. vegetable oil
2 Tbl. molasses
1-1/2 cup rye flour
1-1/2 cup bread flour
1 cup whole wheat flour
1/3 cup gluten
1/4 cup dry milk powder
1 Tbl. caraway seeds
1 Tbl. cocoa
1-1/2 tsp. salt
2 tsp. dry yeast

Light Caraway Rye Bread

Makes a 1-1/2 lb. loaf

1 cup warm water
1-1/2 Tbl. vegetable oil
1 egg
1-1/2 tsp. sugar
1 cup rye flour
2 cups white bread flour
3 Tbl. gluten
1 Tbl. caraway seeds
1 tsp. salt
1-1/2 tsp. dry yeast

Add all ingredients to bread pan in the order given.

Makes a 2 lb. loaf

1-1/3 cup warm water
2 Tbl. vegetable oil
1 egg
2 tsp. sugar
1-1/2 cup rye flour
3 cups white bread flour
1/4 cup gluten
1 Tbl. caraway seeds
1-1/2 tsp. salt
2 tsp. dry yeast



Please Note: If your Bread Machine has a "Fruit & Nut Add-In Beeper," please add raisins when time is indicated. If your Bread Machine does not have this feature, add all ingredients to bread pan in the order given.

Cinnamon Raisin Bread

Makes a 1-1/2 lb. loaf

3/4 cup warm water
1 egg
1 Tbl. butter or vegetable oil
2-2/3 cups all purpose flour
3 Tbl. dry milk
2 Tbl. sugar
1/3 cup raisins
1-1/2 tsp. cinnamon
1 tsp. vanilla
1 tsp. salt
1-1/2 tsp. dry yeast

Add all ingredients to bread pan in the order given.

Makes a 2 lb. loaf

1-1/8 cup warm water
1 egg
1-1/2 Tbl. butter or vegetable oil
3-1/2 cups all purpose flour
1/4 cup dry milk
3 Tbl. sugar
1/2 cup raisins
2 tsp. cinnamon
1 tsp. vanilla
1 tsp. salt
2 tsp. dry yeast

Anadama Oatmeal Bread

Colonial American folk stories about the name Anadama accredit Anna's husband for this bread. The hungry fisherman returned home to find Anna gone and a supper of cornmeal mush and molasses. The legend is he cursed her while preparing his own bread from the meal. Our version with oats, makes great sandwiches, and is terrific with chili.

Makes a 1-1/2 lb. loaf

1/4 cup oatmeal
1/8 cup cornmeal
1-1/8 cup boiling water
2 Tbl. butter or vegetable oil
2 Tbl. molasses
1 cup whole wheat flour
2 cups bread flour
1/4 cup dry milk
2 Tbl. gluten
1-1/2 tsp. salt
1-1/2 tsp. dry yeast

Makes a 2 lb. loaf

1/3 cup oatmeal
3 Tbl. cornmeal
1-1/2 cup boiling water
3 Tbl. butter or vegetable oil
3 Tbl. molasses
1-1/4 cup whole wheat flour
2-1/2 cups bread flour
1/3 cup dry milk
3 Tbl. gluten
2 tsp. salt
2 tsp. dry yeast

- Add oatmeal and cornmeal to heat-proof bowl. Pour in boiling water, stirring to prevent lumps.
- Let the mixture cool for ten minutes. Stir, pour it into the bread pan, and add the rest of the ingredients in the order given.



Seven Grain Bread

If you have a health food store nearby that sells grains and flours in bulk, it is easy to buy a small quantity of a variety of flours, and experiment. Don't worry if you can't find all these grains; just use more whole wheat or another grain.

Makes a 1-1/2 lb. loaf

1-1/8 cup warm water
1-1/2 Tbl. vegetable oil
2 tsp. honey
1-1/2 cup whole wheat flour
1/4 cup brown rice flour
1/4 cup spelt flour
1/4 cup buckwheat flour
1/4 cup rye flour
1/4 cup oatmeal
1/8 cup cornmeal
1/4 cup gluten
1 tsp. salt
1-1/2 tsp. dry yeast.

Add all ingredients to bread pan in the order given.

Makes a 2 lb. loaf

1-1/2 cup warm water
2 Tbl. vegetable oil
1 Tbl. honey
2 cups whole wheat flour
1/3 cup brown rice flour
1/3 cup spelt flour
1/3 cup buckwheat flour
1/3 cup rye flour
1/3 cup oatmeal
1/4 cup cornmeal
1/3 cup gluten
1 tsp. salt
2 tsp. dry yeast

Two Cheese Bread

Makes a 1-1/2 lb. loaf

2/3 cup warm water
1 Tbl. butter or vegetable oil
1 egg
2 tsp. sugar or honey
1/2 cup whole wheat flour
2-1/2 cup bread flour
1/4 cup dry milk
1 cup cheddar cheese, grated (3 oz.)
3 Tbl. Parmesan, grated (1/2 oz.)
2 tsp. sesame seeds
1 tsp. salt
1-1/2 tsp. dry yeast

Add all ingredients to bread pan in the order given.

Makes a 2 lb. loaf

1 cup warm water
1-1/2 Tbl. butter or vegetable oil
1 egg
1 Tbl. sugar or honey
3/4 cup whole wheat flour
2-3/4 cup bread flour
1/3 cup dry milk
1-1/3 cup cheddar cheese, grated (4 oz.)
1/4 cup Parmesan, grated (3/4 oz.)
1 Tbl. sesame seeds
1 tsp. salt
2 tsp. dry yeast



Whole Wheat Zucchini Herb Bread

The zucchini blends into the dough, providing half the moisture and subtle flavor. The bread is so light that a 1-1/2 lb. recipe will be the size of most 2 lb. loaves.

Makes a 1 lb. loaf

1/2 cup warm water
2 tsp. honey
1 Tbl. vegetable oil
3/4 cup zucchini, shredded (3 oz.)
3/4 cup whole wheat flour
2 cups bread flour
1/2 tsp. dried basil or rosemary or 1 tsp. fresh
2 tsp. sesame seeds
1 tsp. salt
1-1/2 tsp. dry yeast

Add all ingredients to bread pan in the order given.

Makes a 1-1/2 lb. loaf

3/4 cup warm water
1 Tbl. honey
1-1/2 Tbl. vegetable oil
1 cup zucchini, shredded (4 oz.)
1 cup whole wheat flour
2-1/2 cups bread flour
1/2 tsp. dried basil or rosemary or 1 tsp. fresh
1 Tbl. sesame seeds
1 tsp. salt
2 tsp. dry yeast

Yogurt Whole Wheat Bread

Makes a 1-1/2 lb. loaf

3/4 cup plain nonfat yogurt
1/4 cup warm water
1 Tbl. vegetable oil
1-1/2 Tbl. maple syrup
1-1/8 cup whole wheat flour
1-2/3 cup bread flour
1-1/2 Tbl. wheat germ
1 tsp. salt
1-1/2 tsp. dry yeast

Add all ingredients to bread pan in the order given.

Makes a 2 lb. loaf

1 cup plain nonfat yogurt
1/2 cup warm water
1-1/2 Tbl. vegetable oil
2 Tbl. maple syrup
1-1/2 cup whole wheat flour
2-1/4 cup bread flour
2 Tbl. wheat germ
1 tsp. salt
2 tsp. dry yeast



Sourdough

To capture the tangy flavor of sourdough bread, you need a special fermented batter. This batter called, "starter" is easy to make and keep.

Sourdough Starter

2 cups warm water
1 Tbl. sugar, honey or maple syrup (optional)

2 cups all purpose flour
1 Tbl. dry yeast

- Beat all ingredients together in a 2-quart bowl.
- Cover the bowl with a towel and place it somewhere warm. (Use a towel, not plastic wrap, to allow airborne wild yeast to enter — it will contribute to the unique character and flavor of your starter.)
- The mixture will begin to bubble within a few minutes. Initially, it will double in bulk, but as it begins to ferment, it will settle down.
- Let the mixture sit in a warm place, stirring the liquid back into the batter (as it will separate) once a day for 2-5 days. When the bubbling diminishes and it has a sour, yeasty aroma, it is ready to use.
- Stir the mixture and measure out the amount you need. It will be the consistency of pancake batter.

To keep your starter going:

- Store the finished starter in a sealed jar in the refrigerator.
- Each time you remove some starter to bake, replenish it with equal amounts of flour and water. (If you use 1/2 cup of starter, stir in 1/2 cup each of flour and water.) Then let the starter sit in a warm place for 12 hours and let the yeast bubble and grow again before returning it to the refrigerator.
- A starter can be kept indefinitely — just stir and feed it every week or two. Stirring, removing and replenishing your starter serves to feed the remaining batter.

Sourdough Bread

The yeast in a sourdough starter can replace dry yeast. But the starter yeast works much slower and is typically a three-step method, taking from 6-24 hours for the dough to rise. Our method uses the starter for flavor and adds dry yeast to speed up the process.

Makes a 1-1/2 lb. loaf

1/2 cup sourdough starter
3/4 cup warm water
2 tsp. sugar, honey or maple syrup (optional)
1 Tbl. oil (optional)
3 cups all purpose flour, or bread flour
1 tsp. salt
1-1/2 tsp. dry yeast

Add all ingredients to bread pan in the order given.

Makes a 2 lb. loaf

2/3 cup sourdough starter
1 cup warm water
1 Tbl. sugar, honey or maple syrup (optional)
1 Tbl. oil (optional)
4 cups all purpose flour, or bread flour
1 tsp. salt
2 tsp. dry yeast



The Breadman's World Famous, All-Natural, No-Butter Cinnamon Rolls

Makes 12 rolls

Dough

3/4 plus 2 Tbl. (7 ounces) warm water
1-1/2 Tbl. canola oil
1-1/2 Tbl. honey
1/4 tsp. liquid lecithin
2 cups (9-1/2 ounces) whole wheat flour
3 Tbl. powdered whey
2 tsp. gluten flour
2 tsp. powdered egg substitute
3/4 tsp. fine sea salt
1-1/2 tsp. active dry yeast

Glaze

1/4 cup almond butter
1/4 cup canola oil
1/2 cup honey
1/2 cup powdered whey

For sprinkling on glaze

2 tsp. cinnamon
1/3 cup raisins or chopped nuts (optional)

- Put all the dough ingredients into the bread pan in the order listed. Select "Dough" setting on your machine. Press Start. When the machine beeps, remove the dough. Turn off the machine.
- Place dough on a lightly floured counter or cutting board. Flatten it out slightly and roll it into a 10-by 12-inch rectangle. Stir glaze ingredients together until smooth. Warm gently in a saucepan for a couple minutes if too stiff. Spread half the glaze over the rectangle of dough, leaving a narrow border all around. Sprinkle cinnamon and, if desired, raisins or chopped nuts over the glaze. Beginning at one long side, roll dough into a cylinder and pinch the seam to seal. Cut rolled dough into twelve 1-inch slices.
- Using canola oil, lightly oil a 10-inch round cake pan. Spread remaining glaze mixture over bottom of prepared pan. Set rolls in pan on top of glaze and cover with plastic or damp cloth. Let rolls rise in a warm place until doubled in volume, about 1 hour.
- Preheat oven to 350 °F. Set pan on a baking sheet and bake on the center rack of the oven for 15 to 20 minutes. (Glaze that bubbles over the pan in the oven will spill onto baking sheet.) Invert pan onto a serving platter and let the glaze drip down sides of the rolls. Scrape any remaining glaze from pan onto rolls. Serve warm.



Pizza Dough

A 1 pound recipe makes one medium-thin 12" pizza. A 1-1/2 lb. recipe makes a 15" circle, and 2 lbs. will make 2, 12" pies.

1 lb.	1-1/2 lb.	2 lb.
3/4 cup warm water	1-1/8 cup warm water	1-1/2 cup warm water
1 Tbl. olive oil	1-1/2 Tbl. olive oil	2 Tbl. olive oil
2-1/4 cup all purpose flour	3-1/3 cup all purpose flour	4-1/4 cup all purpose flour
1 tsp. salt	1-1/2 tsp. salt	2 tsp. salt
1 tsp. sugar	1-1/2 tsp. sugar	2 tsp. sugar
1 tsp. dry yeast	1-1/2 tsp. dry yeast	2 tsp. dry yeast

Add all ingredients to bread pan in the order given.

- Set on "Dough-Only" feature if your Bread Machine is equipped with such a selection.
- When done, remove to floured board, if using immediately. Or, place in bowl greased with olive oil, turn dough over to coat it, cover with plastic wrap and refrigerate until ready to use.

Focaccio

- Pat one recipe, any size, of pizza dough into circle about 1/2 inch thick. Place on a baking sheet sprinkled with cornmeal or flour.
- Brush with olive oil and sprinkle with fresh or dried herbs (rosemary, oregano or basil), Parmesan or Romano cheese and black pepper.
- Let dough rise for 15-20 minutes and place in preheated 400°F oven until golden brown.
- **If you have a pizza peel and oven stone:** Place the shaped dough on the cornmeal sprinkled peel, add toppings, let rise, and slide onto the stone in a preheated oven.

