

This Owner's Manual is provided and hosted by [Appliance Factory Parts](#).



Breadman TR444 Owner's Manual

[Shop genuine replacement parts for Breadman TR444](#)



[Find Your Breadman Bread Machine Parts - Select From 41 Models](#)

----- Manual continues below -----

The logo for Breadman, featuring the brand name in a bold, italicized, sans-serif font with a registered trademark symbol, set against a black rectangular background.

Breadman[®]

INSTRUCTION MANUAL

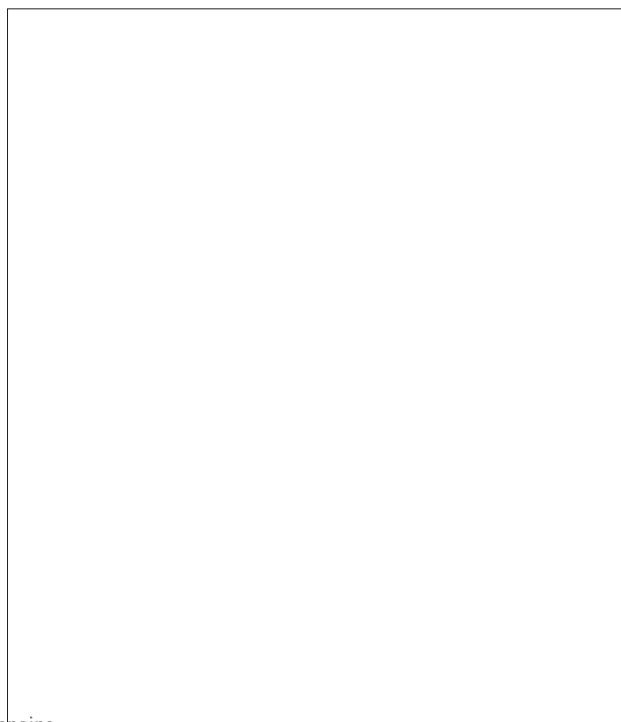



TABLE OF CONTENTS

Important Safeguards	1
Your Breadman®	2
Control Panel	3
Using the Breadman®	4 - 5
Kneading and Baking Cycles	6 - 7
How to Make Bread or Dough	8 - 10
Using the Timer	11 - 12
Cleaning Instructions	13
Recipe: <i>Rich Country Buttermilk Bread</i>	14
Deluxe Rapid Recipe: <i>Basic White</i>	15



IMPORTANT SAFEGUARDS

When using the Breadman® Automatic Bread Baker, basic safety precautions should always be followed, particularly the following:

1. **READ ALL INSTRUCTIONS BEFORE USE.**
2. Do not touch hot surfaces. Use handles or knobs. Always use oven mitts when handling hot materials and allow metal parts to cool before cleaning.
3. Unplug this product from wall outlet when not in use and before cleaning. Allow to cool thoroughly before putting on or taking off parts.
4. Do not immerse appliance in water or any other liquid.
5. Close supervision is always necessary when this or any appliance is used by or near children.
6. Do not allow anything to rest on the power cord. Do not plug in cord where persons may walk or trip on it.
7. Do not operate this or any appliance with a frayed or damaged cord, or after the appliance malfunctions, or has been damaged in any manner. Return
11. Do not let the cord hang over the edge of a table or counter, or touch hot surfaces. Do not place on an unsteady or cloth-covered surface.
12. Do not place the appliance near a hot gas or electric burner, in a heated oven, or in a microwave oven.
13. Keep the unit at least 2 inches away from walls or any other objects when using it.
14. To disconnect, grip the plug and pull it from the wall outlet. Never pull on the cord.

SAVE THESE INSTRUCTIONS

Note:

- A. A short power-supply cord is provided to reduce the risk of becoming entangled in or tripping over a longer cord.
- B. Extension cords are available and may be used, but special care must be exercised in use.
- C. If an extension cord is used:
(1) the marked electrical rating of the



YOUR BREADMAN® AUTOMATIC BREAD BAKER

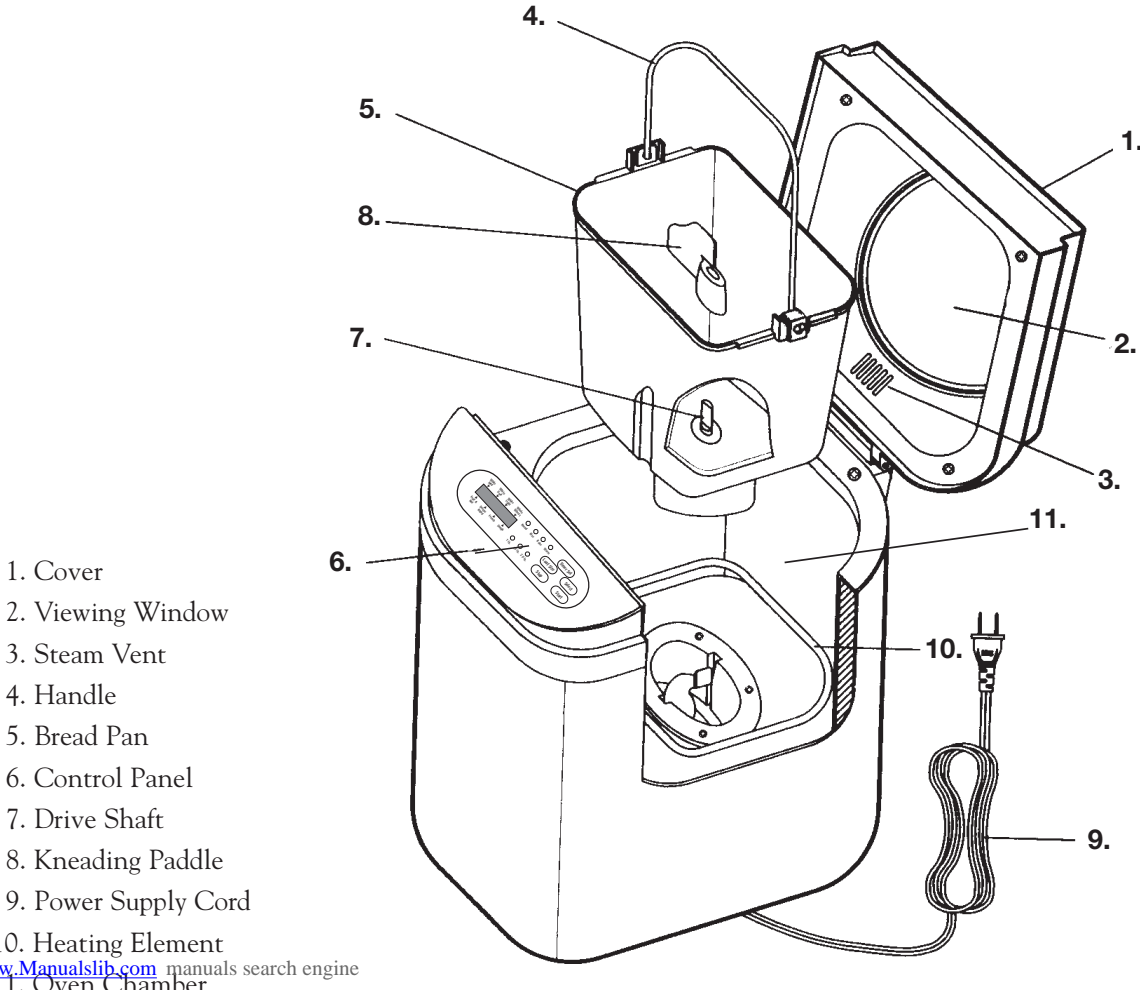

- 1. Cover
- 2. Viewing Window
- 3. Steam Vent
- 4. Handle
- 5. Bread Pan
- 6. Control Panel
- 7. Drive Shaft
- 8. Kneading Paddle
- 9. Power Supply Cord
- 10. Heating Element
- 11. Oven Chamber



CONTROL PANEL

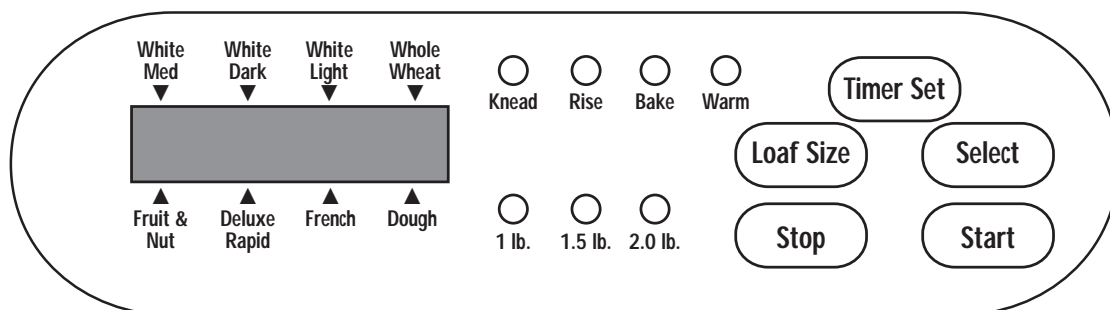

A. Display Window

Shows your selection and Timer setting.

B. Select

Each time this button is pressed, the indicator light inside the Display Window moves to the next selection.

Select from the following choices:

- White Med. (Medium crust color)
- White Dark
- White Light
- Whole Wheat
- Fruit & Nut
- Deluxe Rapid
- French

D. Start

Press this button to start the Baking Cycle you choose, or to start the Timer.

E. Stop

Press this button to stop the machine.

F. Capacity/Loaf Size

Press the **CAPACITY/LOAF SIZE** Button to select what size loaf you would like to bake. You can choose from 1.0, 1.5 or 2 lb. loaves depending on your recipe. Your choice will illuminate on the Control Panel.

***Note: When the SELECT, TIMER SET, START, STOP and CAPACITY/LOAF SIZE Buttons**



USING THE BREADMAN[®] AUTOMATIC BREAD BAKER

Before using the Breadman[®] for the first time, carefully read all of the instructions included in this manual.

With your new Breadman[®] :

- You can use commonly available pre-packaged bread mixes. Follow the instructions on the package.
- You can bake a loaf of bread from scratch. See the *Recipe and Menu Planner* included with your Breadman[®] for lots of tasty options.
- You can make dough for rolls or shaped loaves you'll bake in your own oven.

Use the Breadman[®]'s Dough Cycle to do the mixing and kneading for you , then shape, proof, and bake the bread yourself in a conventional oven.

Inserting and Removing the Bread Pan

- To insert the Bread Pan into the Oven Chamber, seat it in place and press down until it locks into place.
 - * Remember to attach your Kneading Paddle **FIRST**, then add the ingredients.
- **To remove the Bread Pan:** Gently but firmly grab the Handle and pull straight up out of the Oven Chamber. **AFTER BAKING MAKE SURE YOU ALWAYS WEAR OVEN MITTS TO AVOID BEING BURNED.**

Operating Tips

- Use oven mitts when working with bread or any part of the



USING THE BREADMAN® *(continued)*

Caution

- To protect young children, keep the Breadman® out of their reach when there is no supervision; especially during the Kneading and Baking Cycles.
- Use the Breadman® on a flat, hard surface. Do not place it near a flame or heat, or on a soft surface (such as a carpet). Avoid placing it where it may tip over during use. Dropping the Breadman® could cause it to malfunction.
- To avoid burns, stay clear of the Steam Vent during Kneading and Baking Cycles. The Viewing Window can get quite hot as well.
- After baking, wait for the Breadman® to cool down before touching or cleaning the Bread Pan or internals of the machine.
- Never use metal utensils with the Breadman®. These can scratch the non-stick surface of the Bread Pan.
- Avoid electric shock by unplugging the Breadman® before using a damp cloth or sponge to wipe down the interior of the Oven.
- Never use the Bread Pan on a gas or electric cooktop or on an open flame.
- Avoid covering the Steam Vent during Kneading or Baking Cycles. This could cause the Breadman® to warp or discolor.



KNEADING AND BAKING CYCLES

The Breadman® Automatic Bread Baker has several Baking Cycles from which you can choose:

- The White: Light, Medium and Dark Cycles let you choose your favorite type of crust.
- The Fruit & Nut Cycle is for breads such as apple-walnut or raisin bread with higher sugar content.
- The Whole Wheat Cycle is designed specifically for breads that contain whole wheat flour.
- The French Cycle is designed for crispy French or European breads.

The following table shows how long each part of every Cycle takes.

Baking Phase	White Light White Medium White Dark			Whole Wheat			Fruit & Nut			French		
	1.0 lb.	1.5 lb.	2.0 lb.	1.0 lb.	1.5 lb.	2.0 lb.	1.0 lb.	1.5 lb.	2.0 lb.	1.0 lb.	1.5 lb.	2.0 lb.
Timer Set	4:00 - 13:00											
Knead 1	10 min.	15 min.	15 min.	12 min.	15 min.	15 min.	10 min.	15 min.	15 min.	12 min.	15 min.	15 min.
Rest	28 min.	30 min.	32 min.	23 min.	30 min.	30 min.	35 min.	33 min.	32 min.	33 min.	33 min.	32 min.
Knead 2*	12 min.	20 min.	20 min.	15 min.	15 min.	20 min.	15 min.	22 min.	25 min.	15 min.	22 min.	20 min.
Rise	20 min.	20 min.	23 min.	30 min.	25 min.	25 min.	25 min.	20 min.	23 min.	35 min.	25 min.	28 min.
Punch Down	5 sec.	5 sec.	5 sec.	5 sec.	5 sec.	5 sec.	5 sec.	5 sec.	5 sec.	5 sec.	5 sec.	5 sec.
Final Rise	60 min.	60 min.	60 min.	70 min.	70 min.	70 min.	60 min.	60 min.	60 min.	70 min.	70 min.	70 min.
Bake	50 min.	55 min.	60 min.	50 min.	55 min.	60 min.	55 min.	60 min.	65 min.	55 min.	65 min.	75 min.



KNEADING AND BAKING CYCLES *(continued)*

Baking Phase	Deluxe Rapid			Dough		
	1.0 lb.	1.5 lb.	2.0 lb.	1.0 lb.	1.5 lb.	2.0 lb.
Knead 1	15 min.	15 min.	15 min.	10 min.	15 min.	17 min.
Rest	—	—	—	30 min.	30 min.	30 min.
Knead 2*	—	—	—	10 min.	15 min.	18 min.
Rise	—	—	—	20 min.	20 min.	20 min.
Punch Down	—	—	—	5 sec.	5 sec.	5 sec.
Final Rise	16 min.	16 min.	16 min.	—	—	—
Bake	28 min.	28 min.	28 min.	—	—	—
Total Time	0:59	0:59	0:59	1:10	1:20	1:25
Keep Warm	180	180	180	—	—	—

© Copyright 1999, Breadman®



HOW TO MAKE BREAD OR DOUGH

Always use the freshest ingredients available. By carefully following the simple recipes that come with the Breadman[®], you will be able to bake delicious bread every time.

STEP 1

Open the Lid and remove the Bread Pan.

Gently but firmly lift the Bread Pan straight out of the Oven Chamber.

STEP 2

Position the Kneading Paddle on the Drive Shaft as shown.

Match the flat side of the Drive Shaft to the flat part of the hole in the Kneading Paddle. Make sure the Paddle is secure.

STEP 3

Place the ingredients into the Bread Pan.

STEP 4

Make a small indentation on top of the dry ingredients (not so deep it reaches the wet layer) and add the yeast to the indentation.

This order of adding ingredients is important, especially when using the Timer, because it keeps the yeast away from the liquid ingredients until it's time to knead them together. (Liquid ingredients will activate the yeast.)

STEP 5

Insert the Bread Pan into the Oven Chamber.

Seat the Pan into place and gently but firmly press straight down until it locks into place.

Close the Lid and plug in the



STEP 6

Press the **SELECT** Button to choose the Cycle you want.

As you press **SELECT**, the Indicator Light in the Display Window will move to indicate all of the Cycle options. It will move in this order:

White Medium
White Dark
White Light
Whole Wheat
Fruit & Nut
Deluxe Rapid
French
Dough

If the **SELECT** Button is not pressed, and **START** is activated, the Breadman® will automatically bake a White Medium loaf.

STEP 7

Press the **CAPACITY/LOAF SIZE** Button to select which size loaf you would like to bake.

Every time this button is pressed the indicator light will move to a different setting. The selections are:

STEP 8

Press **START** to begin your chosen Cycle.

First, the Breadman® will mix the ingredients. Then it begins the Kneading Process. During this process, the yeast begins to activate. The Breadman® will go through two Kneading Cycles with a rest period in between. After this process the bread dough will rise before baking.

If you plan on making bread with dried fruit or nuts in it, add these ingredients when the Breadman® beeps several times after the **second** Kneading Cycle. This will occur in all Cycles except for the Dough Cycle.

When baking bread, the machine will beep at the end of the Baking Cycle. If the bread is not taken out of the machine immediately, a 3-hour Keep Warm Function will begin*. However, for best results it is best to remove the finished loaf right away. **Use oven mitts to carefully remove the Baking Pan.**

***Note: The Keep Warm Function will not begin for the Dough Cycle.**



STEP 9

When your bread is done, the Breadman® will beep. This indicates that the Baking phase is completed. Press the **STOP Button**, then put on your oven mitts and remove the Bread Pan.

Remember that the Bread Pan and your loaf are both very hot! Be careful not to place either on a tablecloth, plastic surface, or other surface that might scorch or melt.

For all Cycles except Dough:

If the bread is not removed immediately after baking and if the **STOP Button** is not pressed, a controlled Keep Warm Cycle will begin and the machine will automatically shut off after 3 hours. While this will help prevent the bread from becoming soggy, **for best results**, remove bread immediately after the Baking Cycle is complete.

STEP 10

Remove the loaf from the Bread Pan.

Turn over the Bread Pan a few inches from the countertop and gently shake out the loaf. It's best to remove the loaf as soon as the machine is done baking.

Place the loaf on a wire rack or other ventilated cooling surface to cool. Bread should be cooled slightly (30 minutes) before it is sliced.

If necessary, remove the Kneading Paddle from the loaf.

Sometimes the Kneading Paddle will stick in a loaf of bread. If it does, use a non-metal utensil to gently remove it, taking care not to scratch the Kneading Paddle.

When you are done using the Breadman®, be sure to unplug it.



USING THE TIMER

You can preset your Breadman[®] to cook bread from 4 hours to 13 hours in advance.

Note: *Do not use the Delay Timer if your recipe includes eggs, fresh milk or other ingredients that may spoil.*

To preset your Breadman[®], follow these steps:

1. Add your ingredients as usual, taking care not to let the yeast and liquid ingredients contact one another.
2. Close the Breadman[®] Lid and plug it in.
3. Press the **SELECT** Button for the Baking Cycle you prefer as well as the **CAPACITY/LOAF SIZE** Button for the size loaf you wish to bake.
4. Press the **TIMER SET** Button once for each 10 minutes you want to add.

The amount of time set is shown in the Display Window.

Note: *To fast forward time, continually press the **TIMER SET** Button.*

For example, if it is 8:00 PM and you want a loaf of bread ready at 7:00 AM, that is 11 hours from now, press the **TIMER SET** Button until 11:00 appears on the Display.

5. Press **START** Button to begin the Timer. The colon (:) in the Display Window begins to flash, letting you know the Timer is started.



USING THE TIMER *(continued)*

For Best Results

- Take care to measure ingredients accurately, using a good set of measuring cups and spoons, or a good scale. Make sure to level all dry ingredients as you measure them. Inaccurate measuring could cause unexpected results in your loaf of bread.
- In particular, be precise in measuring the water.
- Use fresh ingredients.
 - Since moisture is an enemy to flour, be sure to store your flour in an airtight container.
 - To keep your yeast active, store it in an airtight container in your refrigerator.
- ***Speaking of fresh*** — when using the Timer, we recommend setting it for as short a time as possible. Because ingredients are partially combined in the Bread Pan, the dough may tend to deteriorate if left too many hours, especially on a warm or humid day.
- Keep the Lid closed during the Baking Cycle. Opening it causes uneven baking.
- After your bread has cooled completely, store it in a brown paper bag.



CLEANING INSTRUCTIONS

The Bread Pan and Kneading Paddle have non-stick surfaces that make cleaning easy.

1. After baking each loaf of bread, unplug the Breadman[®] and discard any crumbs.
2. Remove the Bread Pan from the Oven and the Kneading Paddle from the Bread Pan. Then, as needed, wash the Bread Pan and Kneading Paddle inside and out with warm, soapy water. Avoid scratching the non-stick surfaces.
DO NOT PUT THE PAN IN A DISHWASHER.

If the Kneading Paddle is stuck to the Drive Shaft, pour warm water in the Pan to loosen it.

DO NOT USE EXCESSIVE FORCE.

3. Wipe the inside of the Lid and Oven with a damp cloth or sponge. If any residue has scorched on the Heating Plate or elsewhere, wipe with a non-abrasive scrubbing pad and wipe clean.

Do not use vinegar, bleach, or harsh chemicals to clean the Breadman[®].

Do not soak the Bread Pan for a long period of time — this could interfere with the free working of the Drive Shaft.

Be sure the machine is completely cooled before storing.

The inner casing contains the heating element and drive base. Therefore, when cleaning, **NEVER pour water, solvents or cleaning solutions into this area.**



RECIPE

Rich Country Buttermilk Bread

	1 lb.	1-1/2 lbs.	2 lbs.
Non Fat Buttermilk	3/4 cup	1 cup + 2 Tbl.	1-1/2 cups
Unbleached Bread Flour	2-1/2 cups	3-1/4 cups	4-1/4 cups
Sea Salt 1 tsp.	1-1/2 tsp.	2 tsp.	
Butter or Canola Oil	2 Tbl.	3 Tbl.	1/4 cup
Honey 2 Tbl.	3 Tbl.	1/4 cup	
Baking Soda 1/4 tsp.	1/4 tsp.	1/2 tsp.	
Active Dry Yeast	1-1/4 tsp.	1-1/2 tsp.	1-3/4 tsp.

To prepare *Rich Country Buttermilk Bread*:

- Always use fresh ingredients.
- Always put liquids in the Bread Pan first, yeast last.
- Always allow the bread to cool thoroughly prior to slicing.



DELUXE RAPID BREAD RECIPE

IMPORTANT

Weather conditions such as temperature, altitude or accuracy in measuring can effect the outcome of a loaf.

We recommend that you use warm water (115°F - 120°F/45°C - 50°C) for best results on the Deluxe Rapid Cycle. We also recommend using a Quick Rise or Rapid Rise Yeast. This yeast will speed the rising action.

Basic White

	1-1/2 lbs.	2 lbs.
Warm Water	1 cup + 2 Tbl.	1-1/4 cup + 2 Tbl.
Oil	4 tsp.	2 Tbl.
Sugar	1 Tbl.	1-1/2 Tbl.
Salt	1-1/2 tsp.	1-1/2 tsp.
Dry Milk	1 Tbl. + 2 tsp.	2 Tbl.



TROUBLE SHOOTING

Symptom	Possible Solutions
Display Window shows nothing	Make sure the machine is plugged in. If nothing appears in the Display Window, unplug and plug in again.
START button doesn't start the machine	Make sure the machine is plugged in. If nothing appears in the Display Window, press SELECT to choose your Baking Cycle. (You must select a Baking Cycle before pressing START.) If the baking area is too hot, the Breadman® will not start because of an automatic safety feature. Remove the Bread Pan with your ingredients, and wait until the Breadman® cools down — about 20 minutes — before starting a new loaf.
Can't set the Timer	If you selected either the Rapid Bake or Dough Cycle, you should not use the Timer. This is because the ingredients should be processed immediately for these cycles.
After starting, the Display Window flashes "H:E3"	If the Bread Machine is too hot, it will not start because of an automatic safety feature. Remove the Pan and let the Bread Machine cool down until "H:E3" disappears and the selection reappears. You may then start the cycle.



TROUBLE SHOOTING *(continued)*

Symptom	Possible Solutions
The Bread Machine does not bake the bread	The Dough program was selected. To bake the bread, choose the appropriate program for baking bread.
Bread has an offensive odor	Check to be sure you added the correct amount of yeast. Measure carefully — too much yeast will cause an unpleasant odor and may cause the loaf to rise too high. Be sure to use only fresh ingredients.
Baked bread is soggy or the bread's surface is sticky	Remove the bread from the Bread Pan as soon as it is done baking. Leaving it in the Pan allows condensation to collect on the sides touching the Pan. Also be sure to cool the loaf on a wire rack; cooling it on a countertop causes the side next to the counter to become soggy.
The Kneading Paddle was stuck in the bread	Make sure the Kneading Paddle is mounted properly before adding ingredients to the Bread Pan and baking. Sometimes denser or crustier loaves of bread may pull the Kneading Paddle out with them when you remove the loaves after baking. When this happens, use a non-metal utensil and gently remove the blade from the bottom of the loaf.
The bread rose too high	Make sure not to add too much yeast, water or flour. Too much of any of these may cause the loaf to rise more than



TROUBLE SHOOTING *(continued)*

Symptom	Possible Solutions
The bread didn't rise at all	Make sure yeast is not left out. Also check the date code on the yeast and that it is always the last ingredient put into the Pan. Make sure the yeast doesn't come into contact with salt or any liquid ingredients.
The dough looks like batter, or the dough ball is still sticky, not smooth and round	During the Kneading process, add 1 tablespoon of flour at a time, letting it mix in well. For most breads, your dough ball should become round, smooth, not sticky to the touch, and should bounce back when you press it with your finger.
The dough ball is lumpy or too dry	During the Kneading process, add 1 tablespoon of water at a time, letting it mix in well.
The bread caved in	Make sure liquids are measured correctly. Next time, reduce your liquids by 2 tablespoons. If you're using fruits or vegetables, make sure they are well drained.
:END: displays	The Baking Cycle is completed.

ONE-YEAR LIMITED WARRANTY

This Salton, Inc. product warranty extends to the original consumer purchaser of the product.

Warranty Duration: This product is warranted to the original consumer purchaser for a period of one (1) year from the original purchase date.

Warranty Coverage: This product is warranted against defective materials or workmanship. This warranty is void if the product has been damaged by accident, in shipment, unreasonable use, misuse, neglect, improper service, commercial use, repairs by unauthorized personnel or other causes not arising out of defects in materials or workmanship. This warranty is effective only if the product is purchased and operated in the USA, and does not extend to any units which have been used in violation of written instructions furnished by Salton, Inc., or to units which have been altered or modified or to damage to products or parts thereof which have had the serial number removed, altered, defaced or rendered illegible. Wear and tear for Bread Pans and Paddles is not considered a manufacturer's defect.

Warranty Disclaimers: This warranty is in lieu of all warranties expressed or implied and no representative or person is authorized to assume for Salton, Inc. any other liability in connection with the sale of our products. There shall be no claims for defects or failure of performance or product failure under any theory of tort, contract or commercial law including, but not limited to, negligence, gross negligence, strict liability, breach of warranty and breach of contract.

Warranty Performance: During the above one-year warranty period, a product with a defect will be either repaired or replaced with a reconditioned comparable model (at Salton, Inc.'s option) when the product is returned to the Salton, Inc.'s warranty period and an additional one-month period. No charge will be made for such repair or replacement.

Service and Repair

Should the appliance malfunction, you should first call toll-free 1-800-233-9054 **between the hours of 8:00 am and 5:00 pm Central Standard Time** and ask for CONSUMER SERVICE stating that you are a consumer with a problem.

In-Warranty Service: For an appliance covered under the warranty period, no charge is made for service or postage. Call for pre-paid return mailing label. (U.S. Customers Only)

Out-of Warranty Service: A flat rate charge by model is made for out-of-warranty service. Include \$15.00 for return shipping and handling.

Salton, Inc. cannot assume responsibility for loss or damage during incoming shipment. For

IMPORTANT NOTICE

If any parts are missing or defective,

DO NOT return this product.

Please call our Customer Service Department for assistance.

800-233-9054 Monday - Friday 8am - 5pm CST

Thank You



If after reading this instruction booklet you still have questions about using the Breadman® Automatic Bread Machine, please write or call:

Salton, Inc.

550 Business Center Drive