

 **Russell Hobbs**



DESIRE MATTE BLACK JUG BLENDER

2 YEAR WARRANTY

RHBL5BLK

RHBL5BLK_IB_RB_FA_070121
Part No. T22-9001949-B

INSTRUCTIONS & WARRANTY

IMPORTANT SAFEGUARDS

When using this appliance, basic safety precautions should always be followed, including the following:
Read all instructions before, and follow whilst using this appliance.

1. Read all instructions before, and follow whilst using this appliance.
2. To protect against electric shock DO NOT immerse cord, plug or motor unit in water or any other liquid.
3. Do not use outdoors or in damp or moist areas.
4. This appliance is not intended for use by persons (including children) with reduced physical, sensory or mental capabilities, or lack of experience and knowledge, unless they have been given supervision or instruction concerning use of the product by a person responsible for their safety. 
5. This appliance is not a toy. Young children should be supervised to ensure they do NOT play with the appliance.
6. Always turn off and unplug from the power outlet when not in use and before assembling, disassembling or cleaning.
7. To disconnect, set the controls to off. Turn off the wall power outlet, then grasp the plug and remove from the wall power outlet. Never pull by the cord.
8. Do not operate any appliance with a damaged cord or plug or after the appliance has malfunctioned, or has been dropped or damaged in any manner. Contact customer service for replacement, examination, repair or adjustment.
9. There are no user serviceable parts. If the power cord is damaged, it must be replaced by the manufacturer or similarly qualified person in order to avoid a hazard.
10. Do not use this appliance for other than its intended use. Using the appliance for other than its intended purpose may result in personal injury.
11. The motor must always be switched off before connecting to the mains supply.
12. Cutting blades are very sharp. Handle the blender and blade assembly with extreme care and caution when emptying the jug and during cleaning.
13. The motor will only operate if the glass jug has been fully inserted into the motor unit.
14. Before switching on, make sure that the glass jug has been assembled correctly and has been seated into the motor unit with the lid attached. Do not start the blender without the lid and measuring cap in place otherwise liquids/ingredients will be ejected. Always place your hand on top of the blender jug lid to hold the jug steady when the blender starts.
15. The blender is not to be operated with an empty glass jug.
16. Allow boiling liquids to cool before you pour them into the blender jug. Pouring boiling liquids into a cold glass jug could cause the jug to crack.
17. Hot liquids/ingredients must be never placed in the blending jug;
 - Hot liquids/ingredients can create pressure and/or may be ejected during blending which may result in a possible scalding hazard.
 - Hot liquids/ingredients may cause the glass blending jug to break.
18. Switch off and unplug the appliance before changing accessories or touching parts that move whilst in use.
19. Average operating time is approximately 1 minute. If further blending is required, allow a rest/cooling period of 1-2 minutes between operations.
20. Do not use on an inclined plane or unstable surface.
21. Keep the blender and the power cord away from the edges of tables or countertops and out of reach of children and persons with disabilities.
22. Do not place the blender on or near any heat sources.
23. Do not use appliance for other than intended purpose.
24. Cleaning or user maintenance shall not be carried out by children without the supervision of a person responsible for their safety.
25. Do not operate from a timer or other remote control system.

26. For added safety, electrical appliances should be connected to a power outlet that is protected by a residual current device (RCD), also often referred to as a 'Safety Switch'. Your switchboard may already incorporate an RCD. If unsure, call an electrician for verification and fitting if necessary.
27. Misuse of the appliance may cause injury.

SAVE THESE INSTRUCTIONS

**THIS APPLIANCE IS INTENDED TO BE USED IN HOUSEHOLD AND SIMILAR APPLICATIONS SUCH AS:
STAFF KITCHEN AREAS IN SHOPS, OFFICES AND OTHER WORKING ENVIRONMENTS;
FARM HOUSES;
BY CLIENTS IN HOTELS, MOTELS, AND OTHER RESIDENTIAL TYPE ENVIRONMENTS;
BED & BREAKFAST TYPE ENVIRONMENT**

Congratulations on the purchase of your new Russell Hobbs Desire Matte Black Jug Blender. Each unit is manufactured to ensure safety and reliability. **Before using the Blender for the first time, please read this instruction booklet carefully and keep it for future reference.** Pass it on if you pass on the appliance.

When using this appliance, basic safety precautions should always be followed.

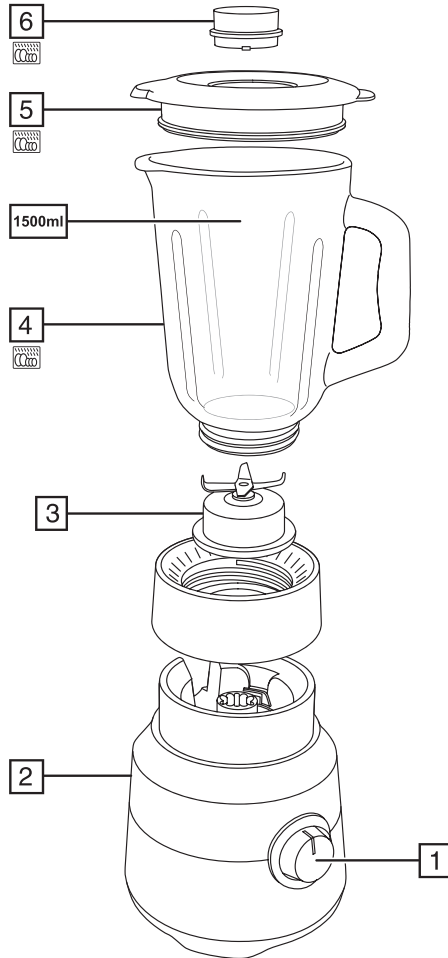

FEATURES

- | | |
|------------------------|--------------|
| 1. Speed selector dial | 4. Glass jug |
| 2. Motor unit | 5. Lid |
| 3. Blade unit | 6. Cap |

PREPARATION

In use, treat the jug and blade unit as a single unit.

1. Sit the motor unit on a stable, level surface.
2. Check that the speed control is set to O.
3. Lower the jug on to the motor unit.
4. Remove the lid.
5. Put the ingredients into the jug. Don't fill past the 1500 ml mark. If you do, the contents may force the lid off when you start the motor.
6. Replace the lid. Don't operate the appliance without fitting the lid.
7. Put the plug into the power socket.
8. Turn the speed control to the speed you want (1 = low, 2 = high).
9. Turn the speed control back to O to turn the motor off.
 - Generally, large quantities, thick mixes, and a high ratio of solids to liquids require longer timings and slower speeds.
 - Smaller quantities, thinner mixes, and more liquids than solids require shorter timings and higher speeds.
 - Turning the speed control anti-clockwise to Ⓢ will give you a short burst at high speed. In this direction, the knob is spring-loaded. When you let go, it'll return to O.
 - To add ingredients while the blender is working, remove the cap, pour the new ingredients through the hole, then replace the cap.
 - Check that the added ingredients don't increase the volume in the jug past the 1500ml mark.

When you have finished:

1. Switch the appliance off (O) and unplug it.
2. Lift the jug off the motor unit.

CARE AND MAINTENANCE

1. Switch the appliance off (O) and unplug it.
2. Wipe the outside of the motor unit with a clean damp cloth.
3. Hand wash the removable parts.

 You may wash these parts in the dishwasher.

If you use a dishwasher, the harsh environment inside the dishwasher will affect the surface finishes. The damage should be cosmetic only, and should not affect the operation of the appliance.

BLADE UNIT

You may wish to remove the blade unit for cleaning.

1. Remove the lid.
2. Sit the jug upside down.
3. Unscrew the blade unit and lift it off.
4. Handle only the plastic – don't touch the metal parts.
5. Wash the blade unit in warm soapy water, rinse, and air dry.
6. Replace the blade unit onto the bottom of the jug.
7. Screw the blade unit firmly onto the bottom of the jug.

BLENDING SPEED SELECTION GUIDE

ACTION	SUGGESTED FOOD TYPE	SPEED SETTING
Aerating	Milkshakes	2
	Thickshakes	2
Blending	Fruit smoothies	2
	Cocktails	2
	Curry pastes	1
Chopping	Chocolate	Ⓢ
	Dried herbs	Ⓢ
	Nuts	Ⓢ
	Coffee beans	Ⓢ
	Seeds	Ⓢ
Combining	Marinades	1
	Mayonnaise	1
	Dressing and Sauces	1
Creaming	Butter and Sugar	1
Crumbing	Breadcrumbs	Ⓢ
	Biscuits	Ⓢ
Crushing	Ice cubes	Ⓢ
Pureeing	Vegetables	2
	Fruits	2
Refining	Sugar	2

CAUTION: When blending any dry ingredients such as nuts, coffee beans, etc., use the Ⓢ function in short bursts only. Running the blender continuously with dry ingredients may result in damage to the blade assembly.

Legislation in some localities mandates that e-waste (anything with a plug, battery or cord) is disposed of through controlled recycling facilities and must not be disposed of in general household waste. For more information about recycling of electrical and battery operated appliances, please contact your local council or your local household waste disposal service.

Spectrum Brands Australia Pty Ltd

Locked Bag 3004 Braeside
Victoria 3195 Australia

Customer Service in Australia

TollFree: 1800 623 118
Email: info@spectrumbrands.com.au
Website: www.spectrumbrands.com.au

Spectrum Brands New Zealand Ltd

PO Box 9817 Newmarket
Auckland 1149 New Zealand

Customer Service in New Zealand

TollFree: 0800 736 776
Email: service@spectrumbrands.co.nz
Website: www.spectrumbrands.co.nz

Spectrum Brands Australia Pty Ltd and Spectrum Brands New Zealand Ltd Warranty Against Defects

In this warranty:

Australian Consumer Law means the Australian consumer law set out in Schedule 2 to the Competition and Consumer Act 2010;

CGA means the New Zealand Consumer Guarantees Act 1993;

Goods means the product or equipment which was accompanied by this warranty and purchased in Australia or New Zealand, as the case may be;

Manufacturer, We or us means:

1. for Goods purchased in Australia, Spectrum Brands Australia Pty Ltd ABN, 78 007 070 573;
or
2. for Goods purchased in New Zealand, Spectrum Brands New Zealand Ltd, as the case may be, contact details as set out at the end of this warranty;

Supplier means the authorised distributor or retailer of the Goods that sold you the Goods in Australia or in New Zealand; and

You means you, the original end-user purchaser of the Goods.

1. Our goods come with guarantees that cannot be excluded under the Australian Consumer Law, or the CGA. You are entitled to a replacement or refund for a major failure and compensation for any other reasonably foreseeable loss or damage. You are also entitled to have the goods repaired or replaced if the goods fail to be of acceptable quality and the failure does not amount to a major failure.
2. The benefits provided by this Warranty are in addition to all other rights and remedies in respect of the Goods which the consumer has under either the Australian Consumer Law or the CGA. The original purchaser of the Goods is provided with the following Warranty subject to the Warranty Conditions:
3. We warrant the Goods for all parts defective in workmanship or materials for a **(Warranty Period)** period of 2 years from the date of purchase.

If the Goods prove defective within the Warranty Period by reason of improper workmanship or material, we may, at our own discretion, repair or replace the Goods without charge.

Warranty Conditions

4. The Goods must be used in accordance with the manufacturer's instructions. This Warranty does not apply should the defect in or failure of the Goods be attributable to misuse, abuse, accident or non-observance of manufacturer's instructions on the part of the user. As far as the law permits, the manufacturer does not accept liability for any direct or consequential loss, damage or other expense caused by or arising out of any failure to use the Goods in accordance with the manufacturer's instructions.
5. Exhaustible components (such as batteries, filters and brushes) of the Goods are included under this Warranty only where there is a defect in workmanship or materials used.
6. The warranty granted under clause 3 is limited to repair or replacement only.
7. Any parts of the Goods replaced during repairs or any product replaced remain the property of the manufacturer. In the event of the Goods being replaced during the Warranty Period, the warranty on the replacement Goods will expire on the same date as for the Warranty Period on the original Goods which are replaced.
8. In order to claim under the warranty granted under clause 3 you must:
 - (a) Retain this warranty with your receipt/proof of purchase; and
 - (b) Return the Goods to us at the relevant address or to the Supplier by prepaid freight within the Warranty Period accompanied with (i) the legible and unmodified original proof of purchase, which clearly indicates the name and address of the Supplier, the date and place of purchase, the product name or other product serial number and (ii) this warranty.
9. This warranty is immediately void if:
 - (a) Any serial number or appliance plate is removed or defaced;
 - (b) The Goods have been serviced or otherwise repaired by a person not authorised to do so by us or where non approved replaced parts are used.
10. The Goods are designed for domestic use only. The Goods must be connected to the electrical voltage requirements as specified in the ratings label located on the Goods.
11. This warranty does not cover the cost of claiming under the warranty or transport of the Goods to and from the Supplier or us.
12. This warranty is only valid and enforceable in Australia against Spectrum Brands Australia Pty Ltd and in New Zealand against Spectrum Brands New Zealand Ltd.

Contact us or the Supplier for further details.

Register your product online

If you live in Australia please visit: www.spectrumbrands.com.au/warranty

If you live in New Zealand Please visit: www.spectrumbrands.co.nz/warranty

Registration of your warranty is not compulsory, it gives us a record of your purchase AND entitles you to receive these benefits: Product information; Hints and tips; Recipes and news; Information on special price offers and promotions.

Any questions? Please contact Customer Service for advice.

Legislation in some localities mandates that e-waste (anything with a plug, battery or cord) is disposed of through controlled recycling facilities and must not be disposed of in general household waste. For more information about recycling of electrical and battery operated appliances, please contact your local council or your local household waste disposal service.

MANGO & RUM COCKTAIL

Serves 2

INGREDIENTS

- 100mL pineapple juice
- ½ ripe mango, stone removed, peeled and roughly chopped
- 1 small banana, roughly chopped
- 40mL rum
- 3 tbs natural yoghurt
- 5 ice cubes

1. Put all ingredients into the Blender jug, ice

cubes last. Blend at low speed for 10 seconds, then high speed for 10 seconds.

STRAWBERRY GIN FIZZ

Serves 2

INGREDIENTS

- 100mL lemonade
- 60mL gin
- 1 tsp lemon juice
- 6 strawberries
- 5 ice cubes

1. Put all ingredients into the Blender jug, ice

cubes last. Blend at low speed for 10 seconds, then high speed for 10 seconds.

IRISH CREAM COCKTAIL

Serves 2

INGREDIENTS

- 100mL milk
- 40g vanilla ice cream
- ½ tsp instant coffee
- 40mL Baileys or Irish cream liqueur
- 3 ice cubes

1. Put all ingredients into the Blender jug, ice

cubes last. Blend at low speed for 10 seconds, then high speed for 10 seconds.

TROPICAL COCKTAIL

Serves 2

INGREDIENTS

200mL ginger beer
150g melon flesh
40mL rum
5 ice cubes

1. Roughly chop the melon.
2. Put all ingredients into the Blender jug. Blend at low speed for 10 seconds, then high speed for 10 seconds

LA MUMBA

Serves 2

INGREDIENTS

300mL chocolate milk
50mL Brandy
3 ice cubes

1. Put all ingredients into the Blender jug. Blend at low speed for 10 seconds, then high speed for 5 seconds.

PINA COLADA

Serves 2

INGREDIENTS

250mL pineapple juice
60mL Malibu
(White rum)
60mL coconut cream
3 ice cubes

1. Put all ingredients into the Blender jug. Blend at low speed for 15 seconds, then high speed until smooth.

BANANA, VANILLA & HONEY SMOOTHIE

Serves 2

INGREDIENTS

- 400mL milk
 - 1 large banana, roughly chopped
 - 4 tsp honey
 - 2 tsp vanilla essence
 - 6 ice cubes
1. Put all ingredients into the Blender jug. Blend at low speed for 10 seconds, then high speed for 10 seconds.

CHOCOLATE SHAKE

Serves 2

INGREDIENTS

- 400mL milk
 - 2 scoops chocolate ice cream
 - 4 tbsp chocolate syrup
1. Put all ingredients into the Blender jug. Blend at low speed for 10 seconds, then high speed for 10 seconds.

BANANA NUT SMOOTHIE

Serves 2

INGREDIENTS

150g hazelnut yoghurt
1 large banana, roughly
chopped
200mL milk
6 ice cubes

1. Put all ingredients into the Blender jug, ice cubes last. Blend at low speed for 10 seconds, then high speed for 5 seconds.

MANGO LASSI

Serves 2

INGREDIENTS

200mL natural yoghurt
1 ripe mango
200mL milk
2 tsp honey
10 ice cubes

1. Peel the mango, remove the flesh from the stone and chop the flesh roughly.
2. Put all ingredients into the Blender jug. Blend at low speed for 10 seconds, then high speed for 5 seconds.

SAVOURY CHEESE BALLS

Makes 20

INGREDIENTS

250g soft cream cheese
½ cup parmesan cheese
grated

2 tsp spring onion, chopped
1 tsp worcestershire sauce

1 tsp lemon juice

1 tsp mixed herbs

½ tsp chilli flakes

Pepper, to taste

1 tsp sour cream

Chopped mixed nuts, toasted

1. Scoop cheese into the Blender jug. Add parmesan cheese, spring onion, worcestershire sauce, lemon juice, herbs, chilli and pepper to the Blender jug.
2. Blend lightly at low speed and add sour cream to lighten mixture. Blend at low speed until smooth.
3. Scoop into a bowl and chill until firm enough to handle easily.
4. Roll into walnut sized balls and then roll each in chopped nuts.
5. Serve on a platter with crackers, grapes and dried fruits.

BERRY FRUIT SMOOTHIE

Serves 2

INGREDIENTS

300mL apple juice

90g raspberries

12 strawberries

4 ice cubes

1. Put all ingredients into the Blender jug. Blend at low speed for 15 seconds, then high speed for 15 seconds.

TAPENADE

Makes approx. 2 cups

INGREDIENTS

- 100g pitted olives
 - 6 bottled anchovies
 - 100g tuna, flaked
 - 1 tsp Dijon mustard
 - 1 tsp capers
 - 200mL virgin olive oil
1. Place olives into the Blender jug and at low speed, chop coarsely. Chop anchovies and add to the olives with tuna, capers and approx 1/3 of the olive oil.
 2. Process until just blended, scraping down the sides of the bowl if necessary. Gradually add the rest of the oil and process until smooth.

CORIANDER PESTO

Makes approx. 2 cups

INGREDIENTS

- 4 handfuls fresh coriander
 - 250mL olive oil
 - 4 cloves fresh garlic
 - 80g pine nuts
 - 120g grated parmesan cheese
 - Salt & pepper, to taste
1. Put the coriander, garlic and pine nuts into the Blender jug. Add a tablespoon of oil, and pulse until combined. Repeat until all the oil has been blended through.
 2. Mix in the parmesan cheese and season with salt and pepper.
 3. Serve tossed through warm pasta, or as a dip.

www.russellhobbs.com.au
www.russellhobbs.co.nz

RUSSELL HOBBS® and logo are Trade Marks of Spectrum Brands, Inc., or one of its subsidiaries. ©2020 Spectrum Brands, Inc.

Recipes are to be used in conjunction with the RHBLSBLK Desire Matte Black Jug Blender by Russell Hobbs. All rights reserved. No part of this publication may be reproduced, stored in a retrieval system or transmitted in any form or by any means, electronic, mechanical, photocopying, recording or otherwise, without prior permission of the copyright owner.

RHBL5BLK

2 YEAR WARRANTY

DESIRE MATTE BLACK JUGE BLENDER

RHBL5BLK_IB_RB_FA_070121
Part No. T22-9001949-B



 Russell Hobbs