

Russell Hobbs RHBI18WC1SS Owner's Manual

[Shop genuine replacement parts for Russell Hobbs RHBI18WC1SS](#)

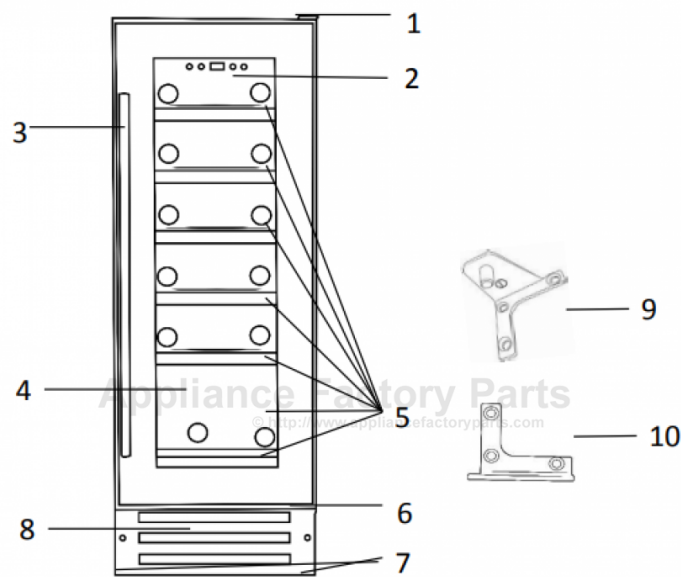

- | | |
|-----------------------|-------------------------------------|
| 1. Upper hinge | 7. Adjustable feet |
| 2. Handle | 8. Vents |
| 3. Controls & display | 9. Door reversal left top hinge |
| 4. Glass door | 10. Door reversal left bottom hinge |
| 5. Bottle racks | |
| 6. Lower hinge | |

[Find Your Russell Hobbs Refrigerator Parts - Select From 31 Models](#)

----- Manual continues below -----



Russell Hobbs

18 Bottle Built in Wine Cooler Instruction Manual

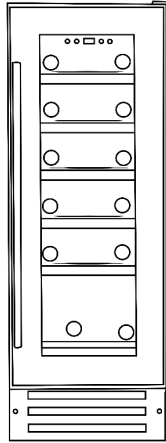

Model number(s):
RHBI18WC1 (SS)

For Customer Services & Spare Parts please call **0345 208 8750**
Opening times: Monday - Friday 8am – 8pm & Saturday 9am – 1pm
or visit us at www.productcare.co.uk

IMPORTANT:
RETAIN FOR FUTURE REFERENCE

Contents

Safety Instructions	3-4
Electrical Safety	4
Transportation & Handling	5
Installing & Switch on your Appliance	5
Before Switching On	6
Product Overview	7
Unit & Spare Parts	7
Positioning & Installation	8-9
Handle Installation	9
Usage	10-16
Door Reversal	17-20
Energy Saving Advice	21
Maintenance & Cleaning	22
Internal Cleaning	22
External Cleaning	22
When not in Use	22
Defrosting	23
Trouble Shooting	24-26
Connection to the Mains Supply	27
Guarantee	28
Technical Specification	29
Notes	30-31



For Customer Services & Spare Parts please call **0345 208 8750**
Opening times: Monday - Friday 8am – 8pm & Saturday 9am – 1pm
or visit us at www.productcare.co.uk

Safety Instructions

Important note: Please read this booklet before installing and switching on this appliance. The manufacturer assumes no responsibility for incorrect installation and usage as described in this booklet.

- This model uses natural refrigerant gas as part of its cooling system. This gas is known as R600a (Isobutene) and is environmentally friendly but can be combustible. Care should therefore be taken when handling or transporting the product to ensure that none of the refrigeration circuit components are damaged,
- Do not obstruct ventilation openings in the appliance
- The appliance must not be placed or rested on its power cord.
- Do not use mechanical devices or other artificial means to accelerate the defrosting process, such as a heater or a hair dryer.
- Do not use electrical appliances in the cooler compartment of the appliance.
- If this appliance is to replace an old cooler with a lock, the lock must be removed as a safety measure before storing it or disposing of it. This is to protect children from locking themselves inside the appliance.
- Old coolers, fridges and freezers contain insulation gases and refrigerant, they must be disposed of properly. Contact your local authority or your dealer if you have any questions. Please ensure that you do not damage the scrap unit prior to being picked-up by the relevant waste disposal service.
- Do not use adaptors or extension leads when connecting the appliance to the electrical power supply
- Do not plug in damaged plugs
- Do not pull, twist or damage the power cable.
- Do not plug-in or un-plug the appliance with wet hands to prevent electrical shock.



Russell Hobbs

For Customer Services & Spare Parts please call **0345 208 8750**
Opening times: Monday - Friday 8am – 8pm & Saturday 9am – 1pm
or visit us at www.productcare.co.uk

- This appliance can be used by children aged from 8 years and above and persons with reduced physical, sensory or mental capabilities or lack of experience and knowledge if they have been given supervision or instruction concerning use of the appliance in a safe way and understand the hazards involved. Children should not play with the appliance.
- This appliance is designed to be used by adults, do not allow children to play with the appliance or let them hang over the door.
- Do not place explosive or flammable material in your appliance for your own safety.
- Bottles containing a high percentage of alcohol must be sealed well
- Do not cover the body or the top of the appliance
- Fix down the accessories in the appliance during transportation to prevent damage to them.

Electrical Safety

THIS APPLIANCE MUST BE PLUGGED INTO AN EARTHED SOCKET

- Before switching on, make sure that the voltage of your electricity supply is the same as that indicated on the rating plate. This product is designed to operate on 230 – 240V AC; 50Hz. Connection to any other power source may damage the unit.
- This product may be fitted with a non re-wireable plug. If it is necessary to change the fuse in the plug, the fuse cover must be refitted. If the fuse cover becomes lost or damaged, the plug must not be used until a suitable replacement is obtained.
- If the plug has to be changed because it is not suitable for your socket, or becomes damaged in any way, it should be cut off and an appropriate plug fitted following the wiring instructions. This should be carried out by a qualified electrician. The plug removed must be disposed of safely, as insertion into a 13 Amp socket is likely to cause an electrical hazard.



For Customer Services & Spare Parts please call **0345 208 8750**
Opening times: Monday - Friday 8am – 8pm & Saturday 9am – 1pm
or visit us at www.productcare.co.uk

Transportation and Handling

For safe lifting, tilt the appliance backwards by no more than 45 degrees, hold the base and rear corners of cabinet. Lift the refrigerator carefully. Never use the door handles for lifting. To move the refrigerator on a flat level surface, tilt it slightly backwards and push backwards.

This unit is heavy and could cause injury – ensure there are adequate people present to move the appliance.

Installing and Switching on Your Appliance

- Operating voltage for your appliance is 230-240V at 50Hz.
- Before plugging in the power supply, ensure that the voltage on the rating label corresponds to the working voltage of your electrical system in your home.
- Insert the plug into an efficient Ground (Earth) connection. If the socket has no Ground (Earth) contact or the plug does not match, we suggest you call an authorised electrician for assistance.
- Place your appliance in an area that is not exposed to direct sunlight.
- Your appliance should be placed at least 10cm away from stoves, ovens and other heating cores.
- This appliance should never be used outdoors or left in the rain.
- When your appliance is placed next to a chest freezer or freezer, there should be at least 10cm between them to prevent humidity on the outer surface.
- The appliance must be used in the vertical position and on a flat surface.
- To level the appliance, use the adjustable feet on the appliance.
- Do not place your appliance on a carpeted surface as this will prevent adequate ventilation.
- This appliance should only be placed on a flat, firm surface.
- Choose a dry and well-ventilated space.
- The appliance should be positioned so that the plug is easily accessible.



Russell Hobbs

For Customer Services & Spare Parts please call **0345 208 8750**
Opening times: Monday - Friday 8am – 8pm & Saturday 9am – 1pm
or visit us at www.productcare.co.uk

- If you need help or are unsure how to install the unit, please contact Customer Services on 0345 208 8750 or visit www.productcare.co.uk.

Before Switching On

- Before using your appliance, add a teaspoon of bicarbonate of soda to warm water and with a damp cloth wipe down all parts of the new appliance, then repeat the process with a clean damp cloth and dry (**ensure the appliance is not connected to the power when performing this task**).
- Remove all transport tapes and foam protection pieces. Clean the interior with a cloth dampened in lukewarm soap and water. Wipe with clean water and wipe dry.
- There may be an odour when you first switch on the appliance, it will disappear when the appliance starts to cool.
- When the appliance has been positioned, adjust the feet to ensure the unit is stable. This is essential to ensure quiet running and proper door opening /closing.
- Connect to the electrical socket but do not switch the power to the refrigerator on for at least 3 hours. The coolant within the product needs time to settle after it has been transported and put in to position, failure to do this will affect the cooling performance of your appliance.
- Once the appliance has settled turn on the appliance, locate the temperature controls on the product and set it to the required temperature.
- You may hear faint gurgling or bubbling sounds when the refrigerant is pumped to the cooling system and through the coils or tubing at the rear of the appliance. When the compressor is in operation you may hear a slight whirring sound or pulsating noise. The temperature controls regulate the operation of the compressor, and you may hear a slight click as it cycles in and out (this is normal).
- To save energy, you should minimize the frequency and duration of door opening.



Russell Hobbs

For Customer Services & Spare Parts please call **0345 208 8750**
Opening times: Monday - Friday 8am – 8pm & Saturday 9am – 1pm
or visit us at www.productcare.co.uk

Product Overview

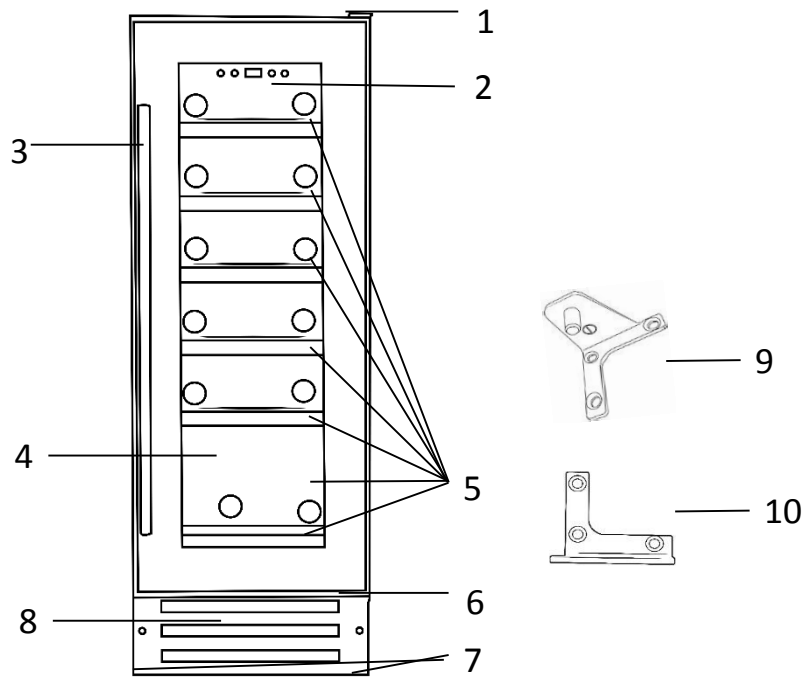

- | | |
|-----------------------|-------------------------------------|
| 1. Upper hinge | 7. Adjustable feet |
| 2. Handle | 8. Vents |
| 3. Controls & display | 9. Door reversal left top hinge |
| 4. Glass door | 10. Door reversal left bottom hinge |
| 5. Bottle racks | |
| 6. Lower hinge | |

Unit Parts & Spare Parts

Before installation, check that all parts detailed in the product overview are present. If any parts are missing, please contact the Product Care Customer Service team on **0345 208 8750** or visit us at www.productcare.co.uk



For Customer Services & Spare Parts please call **0345 208 8750**
Opening times: Monday - Friday 8am – 8pm & Saturday 9am – 1pm
or visit us at www.productcare.co.uk

Positioning & Installation

- This appliance can be installed as a freestanding or a built in unit. The clearances shown in the below drawing should be followed for both types of installation.
- Avoid damaging the product during installation, positioning of the appliance requires two people in order to avoid injuries or damage to the appliance.
- Your appliance should not be located in direct sunlight or exposed to continuous heat or extremes of temperature (e.g. next to a radiator or boiler). If this is not feasible, then you should install an insulation plate between the appliance and the adjacent heat source.
- You should check whether there is an electrical socket available, which will be accessible after your appliance is installed.
- Place the appliance flatly and firmly on a solid base. The appliance is fitted with adjustable feet, which should be used to level the appliance.
- Be sure to leave enough space for the opening of the door, to avoid damage to the appliance or personal injury
- If installing as a built in unit the aperture size has to be a minimum of (H)875 x (W)300 x (D)590mm. The depth dimensions in particular must be observed.

Important: The vent at the base of the appliance is for ventilation. Nothing should be placed in front of this vent; otherwise your wine cabinet may not operate properly.

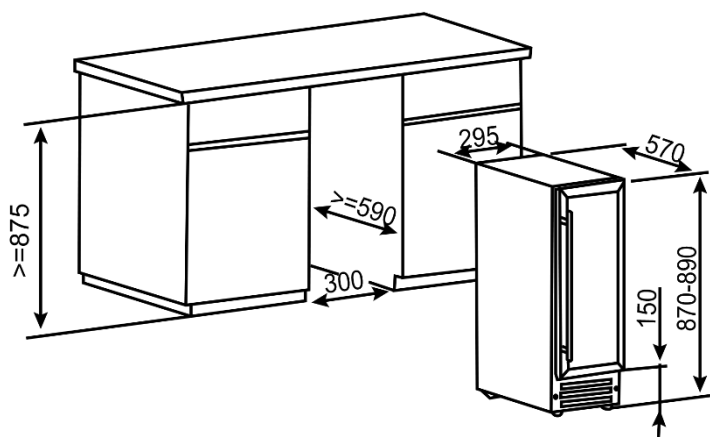

 Russell Hobbs

For Customer Services & Spare Parts please call **0345 208 8750**
Opening times: Monday - Friday 8am – 8pm & Saturday 9am – 1pm
or visit us at www.productcare.co.uk

- A decorative plinth can be fitted to the front of the base vent as long as the cut out shown in the diagram below is made in the plinth. This cut out is required whether the vent is removed or not.

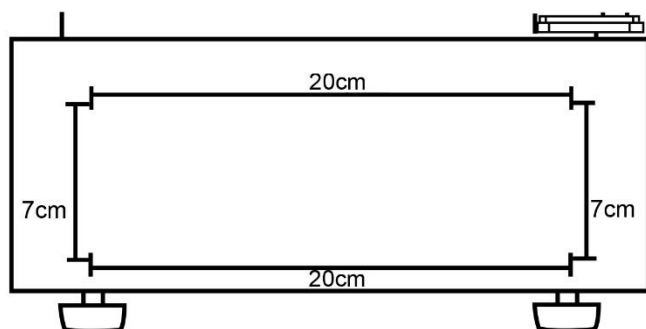

Handle installation

To install the door handle follow the below steps:

1. Open the door of the appliance and move the door gasket slightly to one side so that you can see two designated holes for handle installation
2. Install the handle tightly as shown in the diagram above with the two screws provided.
3. Ensure the door gasket falls back into place and that the door opens and closes correctly.

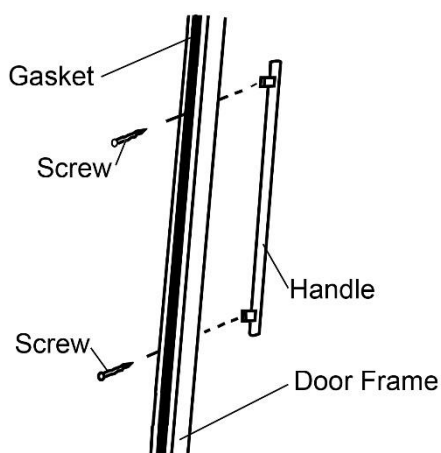

For Customer Services & Spare Parts please call **0345 208 8750**
Opening times: Monday - Friday 8am – 8pm & Saturday 9am – 1pm
or visit us at www.productcare.co.uk

Usage

Control panel

The control panel is situated in the middle of the appliances cavity and has a power, light, temperature up and temperature down touch controls, these are explained below:

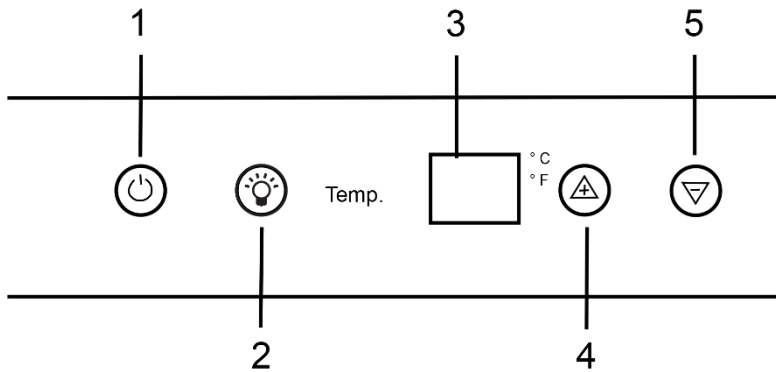

1. Power on/off – press to turn the appliance on and off
2. Light on/off – press to turn the internal light of the appliance on and off
3. Temperature display – displays the internal temperature of the appliance in Celsius or Fahrenheit
4. Temperature up – press to increase the internal temperature of the appliance
5. Temperature down – press to decrease the internal temperature of the appliance



For Customer Services & Spare Parts please call **0345 208 8750**
Opening times: Monday - Friday 8am – 8pm & Saturday 9am – 1pm
or visit us at www.productcare.co.uk

Usage

! Allow to stand for a minimum of 3 hours before plugging in to the mains

During first use

Important: When you use the wine cooler for the first time or restart the appliance after it has been turned off for a long time, there could be a few degrees variance between the temperature you select and the one indicated on the display. This is normal and it is due to the length of activation time. Once the wine cabinet has been running for a few hours everything will be back to normal.

When you first switch on the appliance, the compressor will run continuously until the wine cabinet reaches a cool enough temperature.

During this period of time, you should try not to open the door frequently or place bottles inside of the appliance.

If the unit is switched off or unplugged, you must allow at least 5 minutes before restarting the appliance or reconnecting it to your mains supply.

Switching on the appliance and setting the temperature

Follow the below steps to switch on the appliance and set the required temperature:

1. Switch the appliance on at the plug, then press and hold the power on/off control button for at least 5 seconds. The appliance will beep and the internal temperature of the appliance will be shown on the display.
2. The temperature setting for the appliance is adjustable within the range of 5°C to 22°C or 40°F / 72°F.
3. When you press the temperature up or temperature down controls for the first time, the LED display will show the factory default temperature setting of 12°C / 54°F.
4. Use the temperature up and temperature down controls to set the desired internal temperature.



For Customer Services & Spare Parts please call **0345 208 8750**
Opening times: Monday - Friday 8am – 8pm & Saturday 9am – 1pm
or visit us at www.productcare.co.uk

Usage

5. The temperature will increase by 1°C or 1°F if you touch the temperature up control once and will decrease by the same amount if you press the temperature down control once.
6. When you set a new temperature, the display will show the previous temperature for 5 seconds, before showing the actual temperature. During this time, the cooler temperature will adjust accordingly.
7. To view the set temperature in the wine cooler, press the temperature up) or temperature down control. The display will flash the temperature for 5 seconds.

Note: We recommend that the door is not opened for a minimum of 4 hours to allow the appliance to reach the standard operating temperature.

Note: The temperature of the drinks and how often the door is opened affects the temperature in the cooler. If required, change the temperature setting.

Note: Cool air falls and warmer air rises, so there will be a slight temperature variation between the top of the cabinet and the bottom of the cabinet.

Important: When the temperature is changed, the compressor works harder to reach the required temperature. During this time, the side panels of the wine cabinet can reach up to 45°C however they will cool down when the set temperature is reached.

Changing between Fahrenheit and Celsius

You can select whether the temperature display shows Celsius or Fahrenheit:

1. To change the temperature reading from Celsius to Fahrenheit you must press and hold the light on/off control until the appliance beeps and the °F indicator is lit.
2. You cannot change the display if you are in the process of adjusting the temperature of the wine cabinet.



For Customer Services & Spare Parts please call **0345 208 8750**
Opening times: Monday - Friday 8am – 8pm & Saturday 9am – 1pm
or visit us at www.productcare.co.uk

Usage

Loading the wine cooler

Important: Your appliance is ideally suited to store 0.75 litre Bordeaux style wine bottles. While the cabinet can store larger bottles, you must make sure that they do not prevent the door from shutting properly.

- Always check that you can close the door without it touching on a wine bottle, before shutting it.
- When loading several bottles of wine at once, it will take longer for the appliance to cool the individual bottles.
- As many bottles may differ in size and dimensions, the actual number of bottles you are able to store may vary. The maximum storage number is based on standard 0.75 litre Bordeaux style wine bottles.
- You can place 7 standard size bottles in your appliance with 1 bottle on each shelf.

Storing your wines

The chart below indicates the ideal storage temperatures for different types of wine:-

Type of wine	Examples	Temperature (Celsius)	Temperature (Fahrenheit)
Big, oaky, peppery red	Bordeaux, Shiraz Barolo, Gran Cru Burgundy	18°C	65°F
		17°C	63°F
Medium bodied, fruity, elegant reds	Rioja Reserva, Pinot Noir, Chianti Classico, Chinon, Port	16°C	61°F
		15°C	59°F
		14°C	57°F
Light bodied reds or full bodied, oaky whites	White Burgundy, Lambrusco, Chablis	13°C	55°F
		12°C	54°F
		11°C	52°F
Whites, roses and sweet wines	Chardonnay, Savignon Blanc, Reisling	10°C	50°F
		9°C	48°F
Sparkling wines & champagnes	Vintage Champagnes, Champagne, Prosecco	8°C	47°F
		7°C	45°F
		6°C	43°F



For Customer Services & Spare Parts please call **0345 208 8750**
Opening times: Monday - Friday 8am – 8pm & Saturday 9am – 1pm
or visit us at www.productcare.co.uk

Usage

- Temperature stability is the most important factor when it comes to storing wine.
- Exposure to light, vibrations or fluctuations in temperature and humidity can all cause wine to spoil. When properly stored, wines not only maintain their quality but many will actually improve in aroma, flavour and complexity as they mature.
- Wines kept at a higher temperature will age faster. Wine that is exposed to temperatures that are greater than 21°C (70°F) will suffer from poorer flavour and aroma.
- If wine is kept at too low a temperature, this can result in the development of harmful deposits. A humidity of 70% is ideal for keeping corks from shrinking.
- After a bottle of wine has been opened, the wine comes into contact with air. So it is best to store the remainder of the bottle upright, to minimize the surface area of the wine that is coming into contact with the air.
- Once opened, wine will remain in a drinkable condition for two days for delicate whites or three days for rich reds, as long as the bottle has been resealed. You should make sure that the seal is firm by checking the stopper.
- Special stoppers that keep wine sparkling and Champagne bubbling for one or two days after opening, can be bought.
- When stored correctly, unopened white wines can keep well for up to two years. Full bodied reds (unopened) will age well for ten years and dessert wines (unopened) will age well for up to twenty years.
- When you buy a bottle of wine, you should transfer it to a suitable storage location immediately (if you are not going to store it in your wine cooler).
- Cheaper bottles of wine will not age as well as more expensive ones.
- To make the most of the bouquet and taste of your wine, never fill more than half a glass at a time. It will also help if the shape of your wine glass is appropriate for your wine. The size and shape of your wine glass's bowl will determine the intensity and complexity of the bouquet. The stem should be long enough to allow you to avoid hand contact with the bowl of the glass and should be tulip-shaped or tapered at the top.



For Customer Services & Spare Parts please call **0345 208 8750**
Opening times: Monday - Friday 8am – 8pm & Saturday 9am – 1pm
or visit us at www.productcare.co.uk

Usage

Wine storage problems

Corking - a tiny percentage of bottled wine (about 1%) will suffer from this. The cork reacts with the wine and gives it a musty, unpleasant taste. It is the most common wine storage problem and is caused by harmless bacteria growing on the cork. As unfortunate as this is, there is nothing to do but to discard all of the wine in the affected bottle. This is not to be confused with small fragments of cork floating in the wine itself, which will not impair the flavour.

Oxidisation - when wine has been opened and left for longer than a day; it tends to lose its aroma and colour, giving an overall flat taste. The only way to avoid this, is to either drink the wine on the same day it was opened or to use a vacuum device specially designed for removing oxygen from opened wine bottles. If you use such a device, the wine should still be consumed shortly afterwards.

Ullage - this is loss of wine from the bottle by evaporation or leakage. Signs of ullage include wine seeping around the cork, a protruding cork or a stained label. It can happen if the bottle has been allowed to get too warm. The wine may still be drinkable, if the leakage was recent; however, you should be aware that if the wine cools down again, contraction can cause more air to be sucked into the bottle and result in further deterioration.

Slight effervescence in still wine - this isn't really a problem with the way the wine has been stored, but as a result of incomplete malolactic fermentation before the wine was bottled. A good way to get rid of the effervescence is to let the wine breathe. Alternatively you can use a bottle vacuum device, after about five minutes the effervescence will vanish.

Sediment - this is not normally a problem, however both red and white wines can produce sediment after a number of months in a bottle. The sediment consists of tartrate crystals and is totally harmless. If anything the building of sediment can be considered a good sign because it means that the wine was not subjected to much (if any) filtering, meaning that the flavours and aromas should be preserved better.



For Customer Services & Spare Parts please call **0345 208 8750**
Opening times: Monday - Friday 8am – 8pm & Saturday 9am – 1pm
or visit us at www.productcare.co.uk

Usage

A good way to get around sediment (if it is a problem) is to stand the bottle upright, the day before opening, so that the sediment can settle to the bottom of the bottle.

You can also decant your wine; decanting will “open up” the flavour of both young and old wines, but younger wines in particular. To decant, pour the wine slowly and evenly into your decanter.



For Customer Services & Spare Parts please call **0345 208 8750**
Opening times: Monday - Friday 8am – 8pm & Saturday 9am – 1pm
or visit us at www.productcare.co.uk

Door Reversal

This appliance has the capability of the door opening from either the left or right hand side.

Any parts that you remove from the appliance whilst reversing the door, should be retained for later use.

You will need to tilt the fridge backward to access the lower hinge which holds screws. Do not tilt more than 45 degrees and do not lay the fridge flat on its side.

Reversing the door:

1. Open the glass door and remove the two screws under the bottom hinge. These are used to hold the right lower hinge to the door shaft assembly.

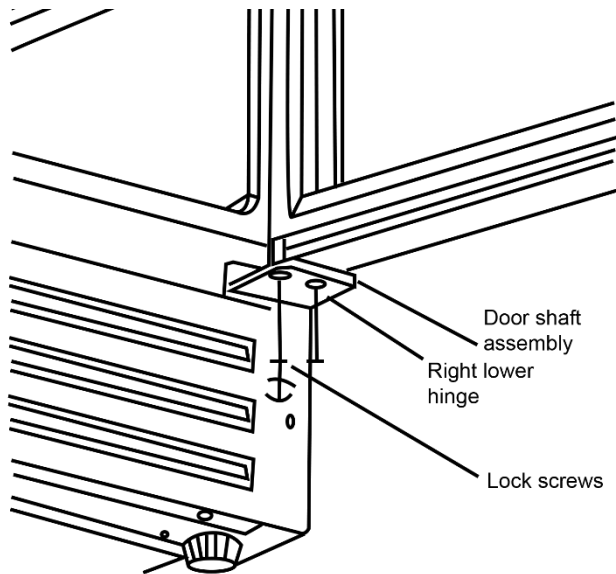

 Russell Hobbs

For Customer Services & Spare Parts please call **0345 208 8750**
Opening times: Monday - Friday 8am – 8pm & Saturday 9am – 1pm
or visit us at www.productcare.co.uk

Door Reversal

2. Be careful to support the glass door with both hands to prevent it dropping after removing the screws. Pull down to remove the glass door and place it on a padded surface to prevent scratching it.

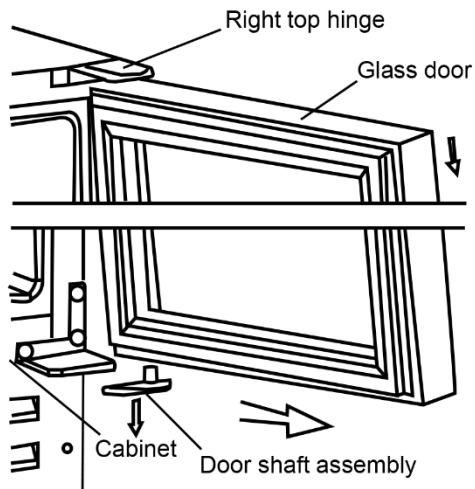

3. Remove the 3 screws from the right top hinge and right lower hinge.

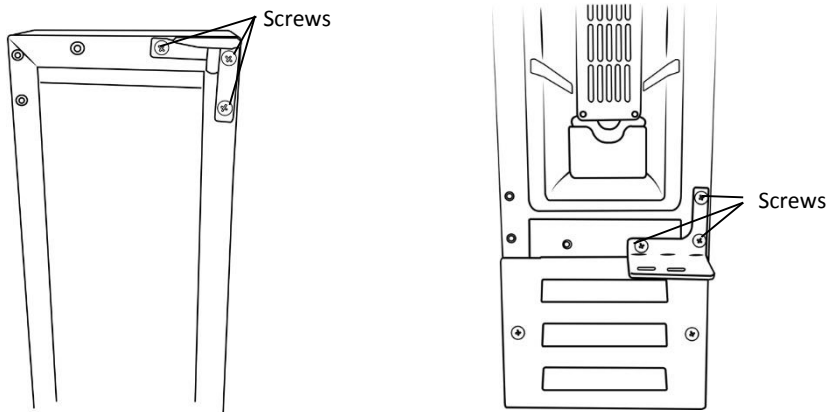

4. Remove the plastic screw covers from the bottom left and top left of the appliance.

 Russell Hobbs

For Customer Services & Spare Parts please call **0345 208 8750**
Opening times: Monday - Friday 8am – 8pm & Saturday 9am – 1pm
or visit us at www.productcare.co.uk

Door Reversal

5. Take the left top hinge and left bottom hinge from the plastic bag that contained this instructional manual then install them in the designated positions on the left side of the cabinet

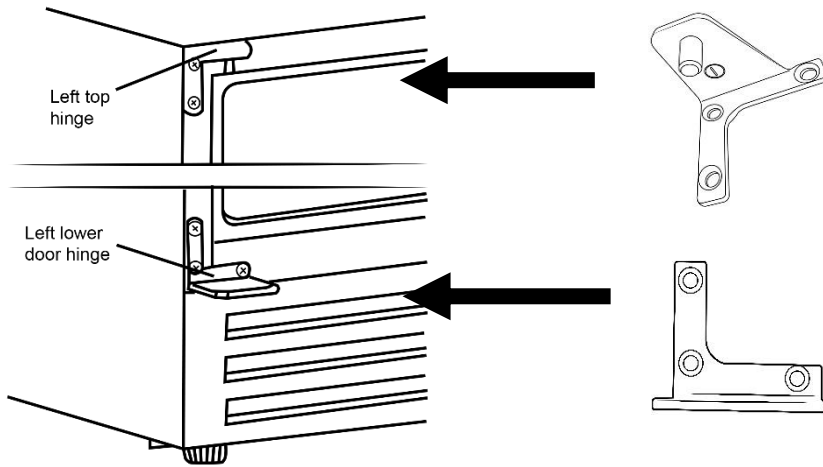

6. Turn the glass door around 180°, put the door shaft assembly from step 1 into the hole on the bottom of the door and reinstall it. Fix the 2 screws to into the top hinge and the door shaft assembly

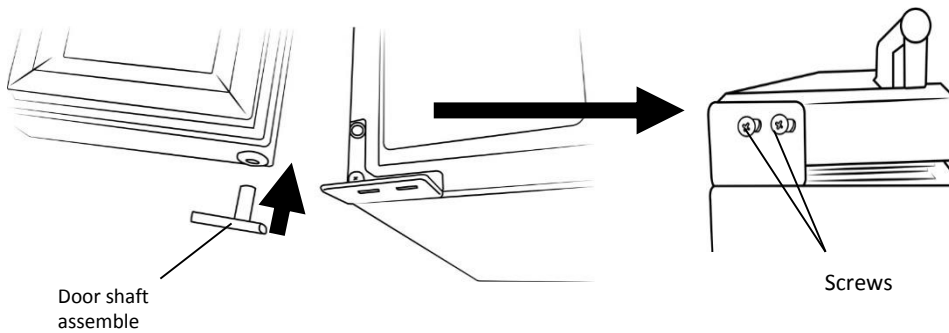

For Customer Services & Spare Parts please call **0345 208 8750**
Opening times: Monday - Friday 8am – 8pm & Saturday 9am – 1pm
or visit us at www.productcare.co.uk

Door Reversal

7. Replace the plastic screw covers from step 4 on the holes on the right hand side.

Check that the door opens and shuts correctly after you have completed the door reversal process.

The appliance must now be upright for a minimum of 3 hours before turning it on.



Russell Hobbs

For Customer Services & Spare Parts please call **0345 208 8750**
Opening times: Monday - Friday 8am – 8pm & Saturday 9am – 1pm
or visit us at www.productcare.co.uk

Energy Saving Advice

- Do not install the appliance close to sources of heat, such as a cooker, dishwasher or radiator.
- Locate the appliance in a cool well-ventilated room and make sure that the air vents are clear.
- Try to avoid keeping the doors open for a long time, warm air will enter the cabinet and may cause a build-up of ice as well as affecting the energy consumption. Ensure there are no obstructions preventing the doors from closing properly.
- Ensure that the door seals are clean and there are no tears or splits.
- Do not overload the appliance; the cooling air that circulates to keep the appliance cold gets blocked and pockets of warm air form.



Russell Hobbs

For Customer Services & Spare Parts please call **0345 208 8750**
Opening times: Monday - Friday 8am – 8pm & Saturday 9am – 1pm
or visit us at www.productcare.co.uk

Maintenance & Cleaning

Disconnect the appliance from the power supply before cleaning.

Internal Cleaning

- Do not pour water over the appliance.
- The cavity should be cleaned periodically using a solution of bicarbonate of soda and lukewarm water (5ml to 0.5 litre of water)
- Clean the accessories separately with soap and water. Do not put them in the dishwasher.
- Do not use abrasive products, detergents or soaps.
- After washing, rinse with clean water and dry carefully.
- When you have finished cleaning reconnect the plug with **dry hands**.

External Cleaning

- Wash the outer cabinet with warm soapy water. Do NOT use abrasive products.
- There are sharp edges on the underside of the product so care should be taken when cleaning.
- Once or twice a year dust the rear of the appliance and the compressor at the back of the appliance, with a brush or vacuum cleaner, as an accumulation of dust will affect the performance of the appliance and cause increased energy consumption.

When the appliance is not in use

When the appliance is not in use for long periods, disconnect from the electricity supply, empty all of the food and clean the inside. Leave the door open to prevent the build-up of odours.



Russell Hobbs

For Customer Services & Spare Parts please call **0345 208 8750**
Opening times: Monday - Friday 8am – 8pm & Saturday 9am – 1pm
or visit us at www.productcare.co.uk

Maintenance & Cleaning

Defrosting

- Defrosting occurs automatically inside of the wine cabinet during operation. The defrost water is collected by the evaporating tray and evaporates automatically.
- The evaporating tray and defrost water drain hole should be cleaned periodically. This will prevent water from collecting in the bottom of the wine cabinet, instead of flowing down the defrost drainage channel and drain hole.
- You can also pour a small amount of water down the drain hole to clean inside of it.
- You should be careful to make sure that wine bottles do not touch the rear wall of the appliance, as this can interrupt the automatic defrosting process and deflect water into the base of your wine cabinet.



Russell Hobbs

For Customer Services & Spare Parts please call **0345 208 8750**
Opening times: Monday - Friday 8am – 8pm & Saturday 9am – 1pm
or visit us at www.productcare.co.uk

Trouble shooting

Problem	Solution
The cooler doesn't work	Check that the appliance is switched on.
	Check that there has not been a power cut.
	Check that the plug is not faulty.
	Check that the fuse has not blown.
	Check that the voltage is correct for the appliance.
	Are there any faults with the socket? For this purpose, try the plug of your appliance by connecting it to a socket which you are sure is working.
Temperature inside the appliance is too warm.	The temperature controls are set too warm. Set the temperature controls to a cooler setting and allow several hours for the temperature to stabilise.
	The door is being kept open too long or is being opened too frequently, which is allowing warm air to enter the appliance.
	The door is not closed completely.
	The door gasket is not sealing correctly.
	The appliance has recently been disconnected from the mains supply; it will take at least four hours for it to get down to temperature again.
Temperature inside the appliance is too cold	The temperature controls are set too cold. Set the temperature controls to a warmer setting and allow several hours for the temperature to stabilise.



Russell Hobbs

For Customer Services & Spare Parts please call **0345 208 8750**
 Opening times: Monday - Friday 8am – 8pm & Saturday 9am – 1pm
 or visit us at www.productcare.co.uk

Trouble shooting

Problem	Solution
Vibration	Check to ensure that the appliance is on a level surface.
	The appliance is touching the back wall behind it. Reposition the appliance and move it from the wall.
	If vibration continues to occur, then turn off the appliance and unplug it from your mains supply. Then contact the Customer Care Department for assistance.
Moisture is forming on the inside of the appliance.	The door is slightly open.
	The door is being kept open too long or is being opened too frequently. Open the door less often.
	The door is not sealed properly.
Moisture is forming on the outside of the appliance.	The door is slightly open, causing cold air from inside the appliance to meet warm, moist air from the outside.
The inner surfaces of the appliance are wet	Caused by condensation - dry the inside of the appliance.
The outer surfaces of the appliance are wet	Caused by condensation - dry the outer of the appliance carefully.
Smell/odour	Check all the drink that is in the fridge is in date and correctly packaged. If it isn't then it should be removed immediately or repackaged.
	Check for spillages on each shelf and rack. Spillages that have not been cleaned and have been left can cause smells and unwanted odours.



For Customer Services & Spare Parts please call **0345 208 8750**
 Opening times: Monday - Friday 8am – 8pm & Saturday 9am – 1pm
 or visit us at www.productcare.co.uk

Trouble shooting

Problem	Solution
The doors do not close properly	Ensure there are no obstructions preventing door closure.
	Check the door compartments and shelves are correctly in place.
	Check the door seal is not warped or torn.
	Check the appliance is level.
Moisture is forming on the inside of the appliance.	The door is slightly open.
Unusual noises	Check that the appliance is on a flat, level surface and is stable.
	Check the spacing's around the appliance and ensure it is not touching other items.
	Bubbling and gurgling sound: This noise is emitted as the coolant fluid flows through the pipes within the system. This is normal.
	Water flowing sound: This is the normal sound of water flowing into the drain trough during the defrosting process.
	If the appliance is operating noisily (compressor noise): This is normal. This noise indicates that the compressor is operating normally. As the compressor is being energized, it might run a bit more noisily for a short period of time.



Russell Hobbs

For Customer Services & Spare Parts please call **0345 208 8750**
 Opening times: Monday - Friday 8am – 8pm & Saturday 9am – 1pm
 or visit us at www.productcare.co.uk

Connection to the Mains Supply

WARNING- THIS APPLIANCE MUST BE EARTHED

This appliance is designed to operate from a mains supply of AC230V - 240V; 50HZ. Check that the voltage marked on the product corresponds with your supply voltage.

For UK use only – Plug fitting details (where applicable):

As the colours of the wires in the mains lead of this appliance may not correspond with the coloured markings identifying the terminals in your plug, proceed as follows:

The GREEN/YELLOW wire is the EARTH and must be connected to the terminal which is marked with the letter E or by the earth symbol or coloured GREEN or GREEN/YELLOW.

The BLUE wire is the NEUTRAL and must be connected to the terminal marked with the letter N or coloured BLACK.

The BROWN wire is the LIVE wire and must be connected to the terminal marked with the letter L or coloured RED.

Always ensure that the plug cord grip is fastened correctly.

If a 13A (BS1363) fused plug is used it must be fitted with a 13amp fuse conforming to BS1362 and be BSI or ASTA approved.



DANGER
Electric
Shock Risk

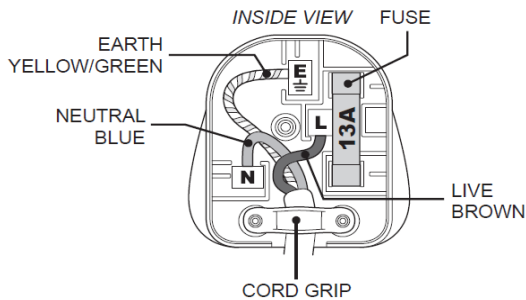

Russell Hobbs

For Customer Services & Spare Parts please call **0345 208 8750**
Opening times: Monday - Friday 8am – 8pm & Saturday 9am – 1pm
or visit us at www.productcare.co.uk

Guarantee

This product is guaranteed for 12 months from the date of the original purchase. If any defect arises due to faulty materials or workmanship you must contact Product Care with the original proof of purchase so a replacement or refund can be arranged.

Refund or replacement is at the discretion of Product Care.

The following conditions apply:

- Product Care will require a valid proof of purchase at the point of replacement or refund.
- The product must be installed and used in accordance with the instructions contained in this instruction guide and any other instructions for use which has been supplied.
- It must be used for domestic purposes only and for its intended use.
- This guarantee does not cover wear and tear, damage, misuse or consumable parts.

This does not affect your statutory rights.

Imported by
G2S LIMITED
WIGAN
WN2 4AY



Russell Hobbs

For Customer Services & Spare Parts please call **0345 208 8750**
Opening times: Monday - Friday 8am – 8pm & Saturday 9am – 1pm
or visit us at www.productcare.co.uk

Technical Specification

Model number	RHBI18WC1 (SS)
Rated Voltage	230V – 240V ~ 50Hz
Capacity	18 bottles
External Dimensions(HxWxD)	870 - 890 x 295 x 570mm



Russell Hobbs

For Customer Services & Spare Parts please call **0345 208 8750**
Opening times: Monday - Friday 8am – 8pm & Saturday 9am – 1pm
or visit us at www.productcare.co.uk

Notes



Russell Hobbs

For Customer Services & Spare Parts please call **0345 208 8750**
Opening times: Monday - Friday 8am – 8pm & Saturday 9am – 1pm
or visit us at www.productcare.co.uk

Notes



Russell Hobbs

For Customer Services & Spare Parts please call **0345 208 8750**
Opening times: Monday - Friday 8am – 8pm & Saturday 9am – 1pm
or visit us at www.productcare.co.uk

For Customer Services &
Spare Parts please call

0345 208 8750

Opening times:

Monday – Friday

8am – 8pm

&

Saturday

9am – 1pm

or visit us at

www.productcare.co.uk

CE



This symbol is known as the 'Crossed-out wheeie bin Symbol'. When this symbol is marked on a product/batteries, it means that the product/batteries should not be disposed of with your general household waste. Only discard electrical/electronic/battery items in separate collection schemes, which cater for the recovery and recycling of materials contained within. Your co-operation is vital to make sure the success of these schemes and for the protection of the environment. For your nearest disposal facility, visit www.recycle-more.co.uk or ask in store for details.

We reserve the right due to possible changes to design to alter the instruction manual without prior notice.

 Russell Hobbs

Revision 1