

This Owner's Manual is provided and hosted by [Appliance Factory Parts](#).



George Foreman GFSBBQ1 Owner's Manual

[Shop genuine replacement parts for George Foreman
GFSBBQ1](#)



[Find Your George Foreman Small Appliance Parts - Select From 306 Models](#)

----- Manual continues below -----

GEORGE FOREMAN®

1 BURNER GAS BBQ GFSBBQ1

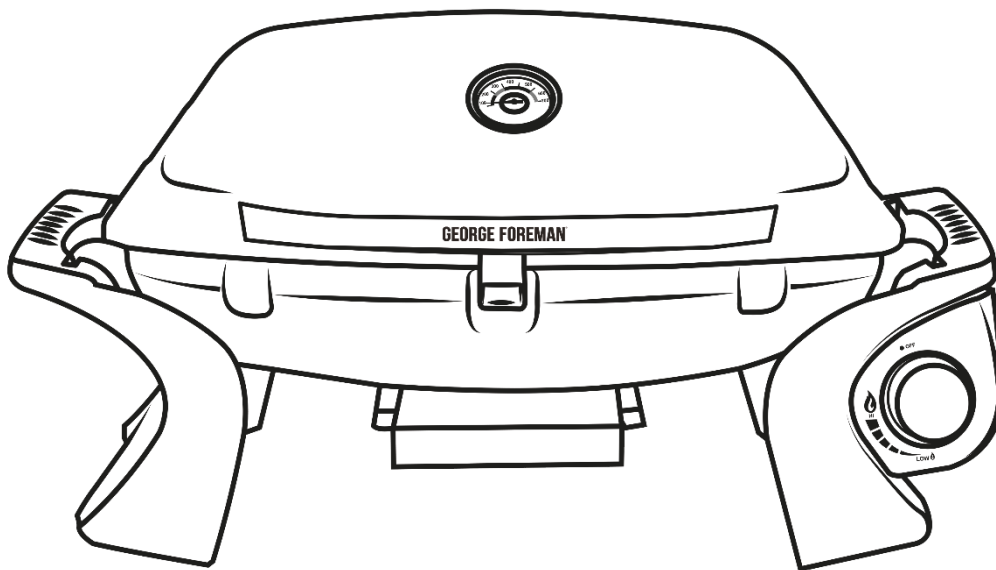

**WARNING: PLEASE ENSURE TO READ THROUGH THE
SAFETY AND OPERATING INSTRUCTIONS BEFORE
USE.**

PLEASE RETAIN INSTRUCTIONS FOR FUTURE REFERENCE

For Customer Services & Spare Parts please call **0345 209 7461**
Or visit us at <https://www.georgeforeman.co.uk/>

CONTENTS

	Page(s)
Safety instructions	3
BBQ Feature Diagram	6
BBQ Parts List	6
BBQ Assembly	7-8
Attaching Gas Cylinder	9
Disconnecting Gas cylinder	10
Lighting your BBQ	11
Food Safety	12
Tips for use	13
Storage	14
Cleaning and care	15
Troubleshooting	16-17
Guarantee and customer services	18
Notes	19

SAFETY INSTRUCTIONS

IMPORTANT SAFETY INSTRUCTIONS **READ CAREFULLY AND KEEP FOR FUTURE REFERENCE**

WARNING:

- The Barbeque must be installed on a secure level base prior to use.
- Read the instructions before using the appliance.
- Always light the barbecue with the lid open.
- Check and clean the grease trays regularly.
- The gas hose should be checked regularly for leaks (especially after long breaks).
- Never use water to extinguish flames.
- Turn off the gas supply at the gas cylinder after use.
- Any modification to the appliance may be dangerous and will void the guarantee.
- Do not store or use gasoline or mentholated fuels or any other flammable vapors and liquids in the vicinity of this appliance. Never light a gas grill with gasoline or similar flammable fluids!
- When the wind speed is above 2m/s don't use the appliance facing in to the wind as this may cause the flame to extinguish.
- Never mount the gas cylinder under the appliance or near any parts of the appliance which becomes hot as this could result in serious injury.
- Use protective heat resistant gloves when handling particularly hot components.
- The appliance must be installed with 1m clearance in all directions around the appliance and should not be used underneath any overhead obstruction.

- In the event of a gas leak, turn off the gas supply at the gas cylinder, extinguish any open flames and keep the lid open. If the leak continues contact your local gas dealer immediately. **DO NOT USE AN OPEN FLAME TO CHECK FOR GAS LEAKS**
- Always test the gas line for leaks with soapy water. If there are leaks you should see bubbles forming.
- The lid must always be open when lighting the appliance.
- Be prepared if an accident or fire should occur. Know where the first aid kit and fire extinguishers are and how to use them.
- Do not heat any unopened glass or metal container on the grill. Pressure may build up and cause the container to burst, possibly resulting in serious personal injury or damage to the appliance.
- **WARNING! This barbecue will become very hot, do not move it during operation.**
- **Do not use indoors or in enclosed spaces!**
- **WARNING! Do not use spirit or petrol for lighting or re-lighting! Use only firelighters complying to EN 1860-3!**
- **WARNING! Keep children and pets away.**

WARNING! Do not use the barbecue in a confined and/or habitable space e.g. houses, tents, caravans, motor homes, boats. Danger of carbon monoxide poisoning fatality.

Safety checks before use:

- If you smell gas shut off gas to the appliance, extinguish any open flames, open lid and if the odour continues, keep away from the appliance and immediately call your gas supplier or your fire department. Leaking gas may cause a fire or explosion which can cause serious bodily injury, death, or damage to property.
- Never operate this appliance unattended, always ensure there are at least two people present.
- Check hose before each use of grill for nicks, cracking, abrasions or cuts. If the hose is found to be damaged in any way, do not use the grill.

Technical data

G2S Ltd. Swan Lane Hindley Green Wigan, WN2 4AY United Kingdom		GEORGE FOREMAN PORTABLE 1 BURNER GAS BBQ GFSBBQ1 Pin Code: 2531CS-0025		
Country of Destination	Appliance Category	Gas and Supply Pressure	Main Burner Injector Size \varnothing	Total Nominal Heat inputs (Hs)
BE, CH, CY, CZ, ES, FR, GB, GR, IE, IT, LT, LU, LV, PT, SK, SI	I3+ (37) <input checked="" type="checkbox"/>	Propane (G31) 37 mbar	0.93mm	3.5kW 249g/h
BE, CY, DK, EE, FI, HU, LT, NL, NO, SE, SI, SK, RO, HR, TR, BG, LU, MT	I3B/P (30) <input type="checkbox"/>	Butane/Propane 30 mbar	0.93mm	3.5kW 255g/h
AT, CH, DE, SK	I3B/P (50) <input type="checkbox"/>	Butane/Propane 50 mbar	0.82mm	3.5kW 255g/h
PL	I3B/P (37) <input type="checkbox"/>	Butane/Propane 37 mbar	0.86mm	3.5kW 255g/h
Use outdoors only. Read instructions before using the appliance. The gas cylinder should not be placed inside the BBQ. Warning : Accessible parts may be very hot. Keep young children away. Made in China				 2531/20

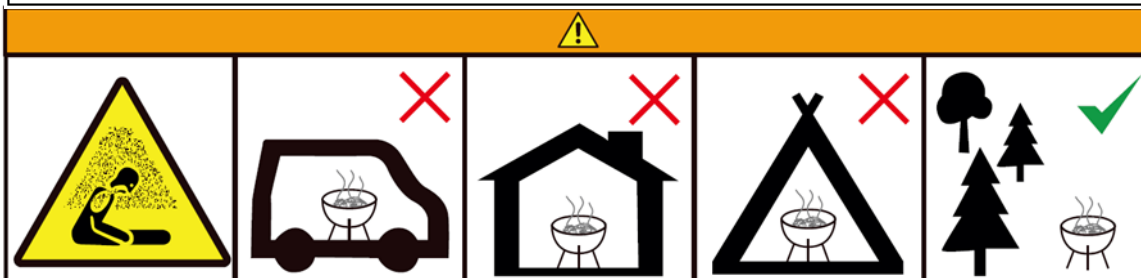

Carbon Monoxide
Poisoning Hazard

Do not use in
Motor Homes

Do Not Use
Indoors

Do Not Use in
Tents

Use in open
Spaces

BBQ FEATURE DIAGRAM

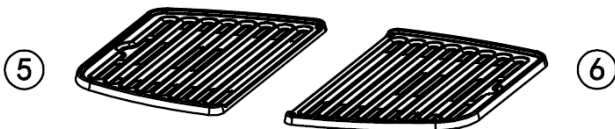
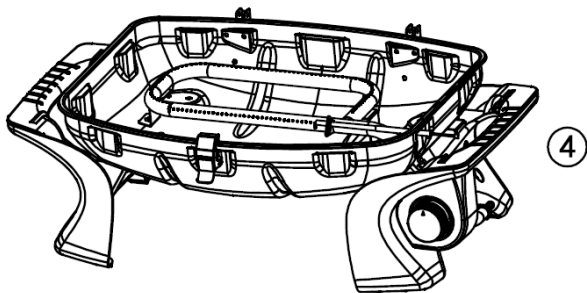
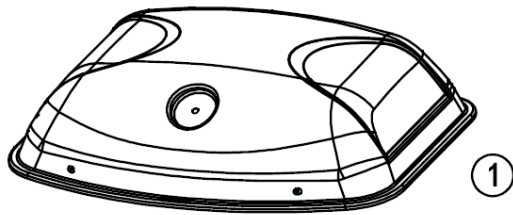

PART	DESCRIPTION	QTY
1	Lid	1
2	Handle Back Plate	2
3	Handle	1
4	Base	1
5	Grill Tray – Left	1
6	Grill Tray – Right	1
7	Thermostat	1
8	Grease Tray	1
A	M5 Wing Nuts	2
B	Pin	2
C	Pin Clip	2

You will need...

- Cross Head Screwdriver
- Adjustable Spanner

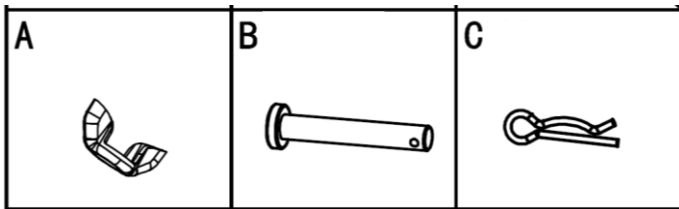

BBQ ASSEMBLY

Assembling the Handle

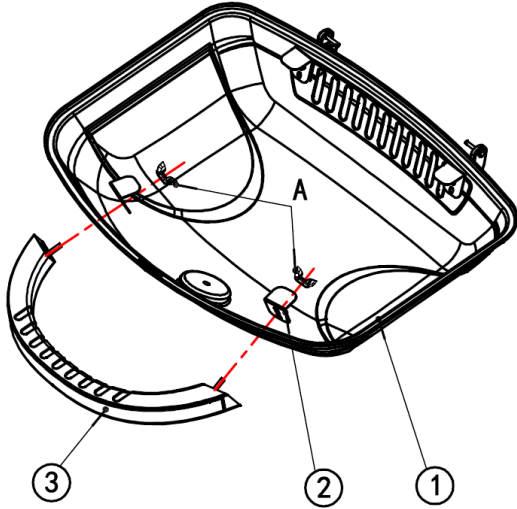

1. Attach the handle (3) and the handle back plates (2) to the lid (1) using two of the M5 Wing Nuts (A).

Ensure that the handle back plates (2) are attached to the inside of the lid.

Assembling the Lid to the Base

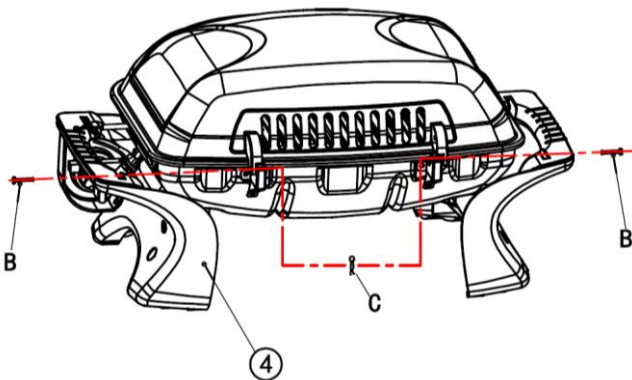

1. Place the **Lid** (1) onto the **Base** (4) with the back of the BBQ facing towards you.

Ensure that the hinges are aligned.

2. Push a **Pin** (B) through each of the hinges, and secure into place using the **Pin Clips** (C)

BBQ ASSEMBLY

Attaching the Thermostat

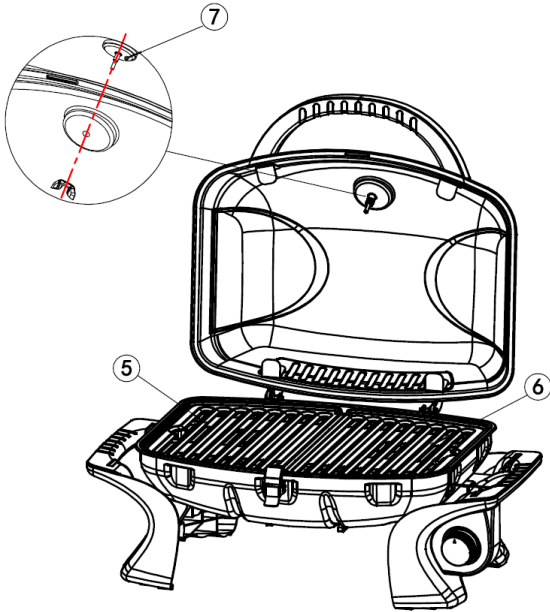

1. Push the leg of the **thermostat** (7) through the hole in the lid of the BBQ.
Ensure that the thermostat is correctly aligned
2. Use a Wing Nut (A) to secure the thermostat in place.
3. Place the **Left and Right Grill Trays** (5&6) in position.

Attaching the Grease Tray

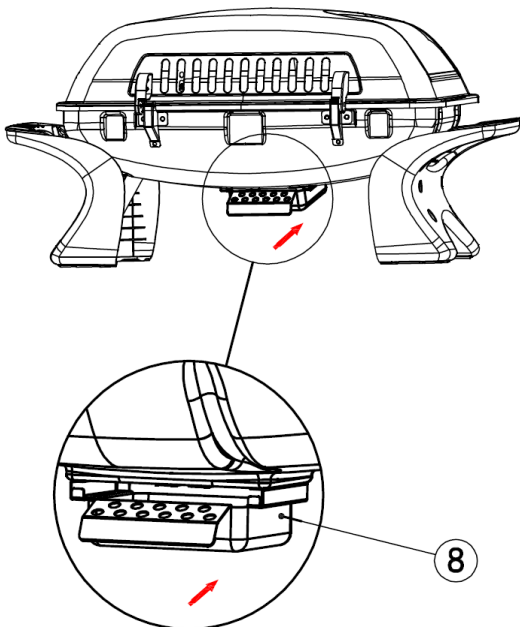

1. Slide the Grease Tray (8) into the grease tray supports, located on the base of the BBQ.

Your portable gas BBQ is now assembled.

ATTACHING YOUR GAS BOTTLE

After purchasing your gas cylinder you will then be ready to set it up with your gas grill.

When changing the gas cylinder it must not be near any source of ignition. Position the gas cylinder at the left side of your gas grill, keeping in mind that the bottle must be kept away from heat and in a safe position.

- When ready to use your gas grill place the regulator onto the gas bottle valve and push down firmly until you hear it click in to place.
- Attach the hose to the regulator gas outlet, you will need to push firmly as it is a tight fit.
- Once the hose is connected to regulator it must be secured in place using one of the two jubilee clips supplied.
- Attach the other end of the gas hose to the gas inlet on the appliance, again you will need to push firmly as it is a tight fit.
- Once the hose is connected use the second jubilee clip to secure in place.
- Ensure that the hose is not subjected to twisting which will affect the gas flow when installing your gas grill. Also the hose must not have undue tension and must not touch any part of the gas grill which may be hot.
- Once the gas cylinder is connected to the appliance you can then start the flow of gas by turning the small lever on the regulator from its closed position (vertical) to its open position (horizontal).

Warning: Always test gas line for leaks at connector with soap water around all connections.

DISCONNECTING YOUR GAS BOTTLE

When you have finished using the appliance you must remove the gas cylinder.

In order to do this you turn the small lever on the regulator from its open position (horizontal) to its closed position (vertical).

Once the gas supply has been turned off you then need to remove the regulator from the gas cylinder. To do this you need to push in the button release which is located below the small lever on the regular and lift away from the gas cylinder.

LIGHTING YOUR BBQ

USING THE AUTOMATIC IGNITION

Caution: The lid must be open when lighting the BBQ
Do not stand with your face directly over the gas grill when lighting it.

1. Ensure the dial is in the “OFF” position.
2. Turn the gas cylinder valve to the “ON” position at the regulator.
3. To create a spark, press the control dial (A) into the BBQ and hold in position for 3-5 second to allow the gas to flow.
Then turn the control dial anticlockwise to “HIGH” (B).
This will create a spark to the burner lighting tube (C) and this should make a “snap” sound and produce an orange flame from the burner lighting tube at the left side of the burner (D)
4. Continue to hold the control dial in position for a further 2 seconds to allow the gas to flow (E) and ensure ignition.

On the “HIGH” setting, the flame should be approximately 12-20mm high with an orange flame.

Turn the gas control fully anticlockwise for the minimum heat setting

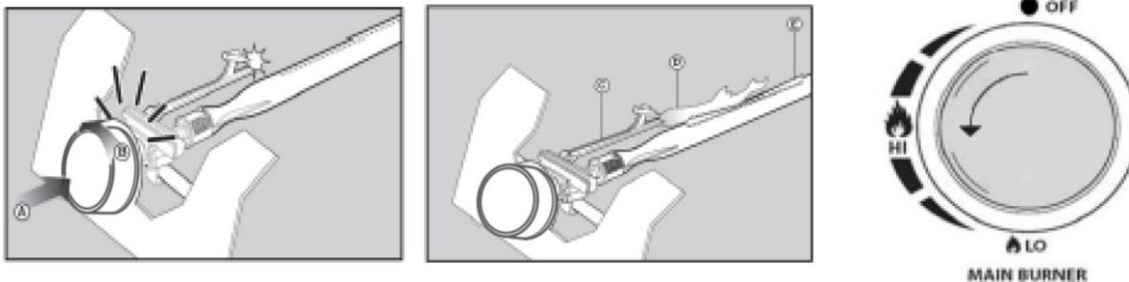

Warning : If the burner still does not light ,turn the burner control knob to” OFF” and wait 5 minutes to let the gas clear before lighting again.

Warning: If the burner goes out while the grill is in operation, turn the control dial to the “OFF” position. Open the lid and wait 5 minutes before attempting to relight the BBQ.

FOOD SAFETY

Thoroughly defrost frozen meat and poultry in the refrigerator before cooking. Keep raw meat and poultry separate from cooked foods.

Always wash hands after handling raw meat and poultry, before handling any ready to eat foods.

Wipe and disinfect surfaces that have been in contact with raw meat and poultry.

When barbecuing meat and poultry, make sure the barbecue is really hot. Place the larger, thicker portions furthest away from the most intense heat to ensure thorough cooking without burning and turn regularly.

Use separate utensils for handling raw meat/poultry and cooked food on the barbecue, or wash them thoroughly between uses.

To check whether meat, particularly poultry, is cooked, pierce the flesh with a skewer or fork; the juices should run clear. Ensure the product is piping hot throughout.

TIPS FOR USE

Preheating the grill before barbecuing is important.

Follow the Lighting your BBQ instructions, then turn control dial to the “HIGH” position and close the lid to preheat the grill.

This will take 10 to 15 minutes depending on conditions such as air temperature and wind. After preheating, you can adjust the control dial as desired.

Food can be barbecued with the lid up or down. Cooking with the lid down will ensure more even cooking.

For every 5 minutes that the lid is down, open the lid for 1 minute to release heat.

To save energy, we recommend:

- Minimising the time the lid is open
- Turn off the BBQ and gas supply as soon as cooking is completed
- Do not preheat the grill for longer than 10 to 15 minutes
- Do not use a higher heat setting than is required.

STORAGE

Your Gas Bottle must be stored outdoors in a well ventilated area and must be disconnected from your gas grill when not being used.

Ensure that you are outdoors and away from any sources of ignition before attempting to disconnect your gas bottle from your BBQ.

We recommend that your BBQ is stored indoors, or in a garage or shed.

When using your BBQ after a period of storage, always check for gas leaks and any obstructions in the burner before using.

CLEANING INSTRUCTIONS

Ensure the appliance is cold before cleaning.

Empty the grease tray after each use and wash in warm soapy water.

Grill trays should be cleaned by soaking and washing in warm soapy water.

The interior surfaces of the grill housing cover should also be washed with warm, soapy water. Use a wire brush, steel wool or a scouring pad to remove stubborn spots.

Periodically check the burner to see that it is free from insects and spiders which may clog the gas system, and deflect the gas flow.

Ensure to clean venturi pipes on burner very carefully, make sure that there are no obstructions. We recommend that you use a pipe cleaner to clean the venturi pipe area.

Any modifications of this appliance may be dangerous and are not permitted.

TROUBLE SHOOTING

PROBLEM	POSSIBLE CAUSE	PREVENTION/ SOLUTION
Gas leaking from cracked/cut/burned hose	Damaged hose	Turn off gas at LP tank, if hose is cut or cracked, replace hose.
Gas leaking from LP tank	Mechanical failure due to resting or mishandling	Turn off LP tank valve and replace.
Gas leaking from LP tank valve	Failure of tank valve from mishandling or mechanical failure	Turn off LP tank valve and replace.
Gas leaking between LP tank and regulator connection	Improper installation, connection not tight, failure of rubber seal	Turn off LP tank valve, remove regulator from cylinder and visually inspect rubber seal for damage.
Fire coming through control panel	Fire in burner tube section of burner due to partial blockage	Turn off control knobs and LP tank valve. After fire is out and grill is cold, remove burner and inspect for spider nests or rust.
Troubleshooting: Problem	Possible cause	Prevention/ Solution
Grease fire or continuous excessive flames above cooking surface	Too much grease buildup in burner area	Turn off LP Tank. Leave lid open to allow flames to die down. After cooling, clean food particles and excess grease from inside firebox area, grease cup/pan/tray, and other surfaces
Burner will not light using ignitor	Gas issues 1. Burner not engaged with control valve 2. Obstruction in burner 3. No gas flow 4. Coupling nut at LP tank valve not fully connected.	1. Make sure valve are positioned inside of burner tubes. 2. Ensure burner tube is not obstructed with spider webs or other material, see cleaning section of use and care 3. Make sure LP tank is not empty. If LP tank is not empty, refer to "sudden drop in gas flow." 4. Turn the coupling nut approximately one-half to three-quarters

TROUBLE SHOOTING

<p>Burner will not light using ignitor</p>	<p>Electrical issues:</p> <ol style="list-style-type: none"> 1. Electrode cracked or broken;" sparks at crack." 2. Electrode tip not in proper position 3. Wire and/or electrode covered with cooking residue. 4. Wires are loose or disconnected 5. Wires are shorting (sparking) between ignitor and electrode. 6. push button sticks at bottom sparking between ignitor and electrode 	<ol style="list-style-type: none"> 1. Replace electrode. 2. Tip of electrode should be pointing toward port hole in burner. The distance should be 1/8" to 3/16". Adjust if necessary. 3. Clean wire and or electrode with rubbing alcohol and clean swab. 4. Reconnect wires or replace electrode/wire assembly. 5. Replace ignitor wire 6. Replace ignitor 7. Inspect wire insulation and proper connection. Replace wires if insulation is broken.
<p>Sudden drop in gas flow or low flame</p>	<ol style="list-style-type: none"> 1. Grease buildup. 2. Excessive fat in meat. 3. Excessive cooking temperature 	<ol style="list-style-type: none"> 1. Clean burners and inside of grill/ firebox 2. Trim fat from meat before grilling.
<p>Flames blow out</p>	<ol style="list-style-type: none"> 1. High or gusting winds. 2. Low on LP gas. 3. Excess flow valve tripped. 	<ol style="list-style-type: none"> 1. Turn front of grill to face away from wind or increase flame height. 2. Refill LP tank. 3. Refer to "sudden drop in gas flow" above.
<p>Persistent grease fire</p>	<p>Grease trapped by food buildup around burner system.</p>	<p>Turn knobs to OFF. Turn gas off at LP tank. Leave lid in open position and let fire burn out. After grill cools, remove and clean all parts.</p>
<p>Flashback... (fire in burner tube(s))</p>	<p>Burner and burner tubes are blocked</p>	<p>Turn knobs to OFF. clean burner and/or burner tubes. See burner cleaning section of use and care manual</p>
<p>Flare-up</p>	<ol style="list-style-type: none"> 1. Grease buildup. 2. Excessive fat in meat. 3. Excessive cooking temperature 	<ol style="list-style-type: none"> 1. Clean burners and inside of grill/ firebox 2. Trim fat from meat before grilling. 3. Adjust (lower) temperature

GUARANTEE AND **CUSTOMER SERVICES**

This product is guaranteed for **12 months** from the date of the original purchase. If any defect arises due to faulty materials or workmanship, the faulty product must be returned to the place of purchase.

Refund or replacement is at the discretion of the retailer.

The following conditions apply:

- The product must be returned to the retailer with the original proof of purchase.
- The product must be installed and used in accordance with the instructions contained in this instruction guide and any other instructions for use which are supplied.
- It must be used for domestic purposes only and for its intended use.
- This warranty does not cover wear and tear, damage, misuse or consumable parts.

This does not affect your statutory rights.

For Customer Services & Spare Parts please call **0345 209 7461**

Or visit us at [**https://www.georgeforeman.co.uk/**](https://www.georgeforeman.co.uk/)

NOTES

GEORGE FOREMAN[®]

1 BURNER GAS BBQ GFSBBQ1

Made by G2S under license.
G2S Ltd, Wigan, WN2 4AY
George Foreman is the registered trademark
of Spectrum Brands (U.K.) Ltd.

Revision 3