

# GEORGE FOREMAN<sup>®</sup>

HEALTHY LIVING



## HealthyCook



# HEALTHYCOOK 5-IN-1 MULTI COOKER

## Instructions & Warranty

## IMPORTANT SAFEGUARDS

When using this appliance, basic safety precautions should always be followed, including the following:

Read all instructions before, and follow whilst using this appliance.

1. To protect against electrical hazards do not immerse the power cord, plug or multi cooker body in water or any other liquid.
2. Do not use in the bathroom or near any source of water.
3. Do not use outdoors.
4. Do not use the appliance near or below any curtains or other combustible materials.
5. The appliance should be positioned so that escaping steam does not damage overhead or surrounding cupboards.
6. Always use the appliance handles and do not touch the hot cooking surfaces. The temperature of accessible surfaces/parts may become very hot when the appliance is operating.
7. This appliance generates heat and escaping steam during use. To avoid risk of burns, stay clear of the steam vent while cooking and wait for the multi cooker to cool down fully before touching the cooking pot and lid.
8. This appliance is not intended for use by persons (including children) with reduced physical, sensory or mental capabilities, or lack of experience and knowledge, unless they have been given supervision or instruction concerning use of the appliance by a person responsible for their safety.
9. Always turn off and unplug from the power outlet when not in use and before cleaning the appliance.
10. To disconnect, turn off the wall power outlet, then grasp the plug and remove from wall power socket. Never pull by the cord.
11. Do not operate this appliance with a damaged cord/plug or after the appliance has malfunctioned, or been dropped or damaged in any manner. Contact Customer service for replacement, examination, repair or adjustment.
12. There are no user serviceable parts. If the power cord or appliance is damaged, it must be replaced or repaired by the manufacturer or similarly qualified person in order to avoid a hazard.
13. Do not use accessories of not specifically designed for use with this product.
14. Do not use on an inclined plane or unstable surface.
15. Cook only in the cooking pot. Do not pour liquid directly into the interior. Doing so may result in personal injury from electric shock and/or damage to the appliance.
16. Do not use the cooking pot if it is dented or distorted.
17. Do not turn on the multi cooker without first placing the cooking pot inside the interior of the multi cooker.
18. Always be sure the cooking pot contains liquid before the multi cooker is switched on.
19. Do not overfill or attempt to cook food items too large for the appliance.
20. Do not fill the multi cooker with cooking oil or try to use it as a deep fryer.
21. Do not use keep warm mode to reheat cold rice or other foods.

22. Always take care when removing food after cooking as it is hot.
23. Keep the appliance and the power cord away from the edge of tables or countertops and out of reach of children and infirm persons.
24. Do not move the appliance when in use.
25. Do not cover the appliance when in use.
26. Do not place on or near any heat sources.
27. Always thoroughly clean the appliance after use.
28. Follow the instructions when cleaning this appliance.
29. Do not use appliance for other than its intended purpose as described in this instruction book.
30. This appliance is not a toy. Children should be supervised to ensure they do not play with the appliance.
31. Do not leave the appliance unattended when in use or where it may be touched by children or persons with disabilities.
32. This appliance is not intended to be operated by means of an external timer or separate remote control system.
33. For added safety, electrical appliances should be connected to a power outlet that is protected by a residual current device (RCD), also often referred to as a 'Safety Switch'. Your switchboard may already incorporate an RCD. If unsure, call an electrician for verification and fitting if necessary.
34. This appliance is intended to be used in household and similar applications such as:
  - Staff kitchen areas in shops, offices and other working environments;
  - Farm houses;
  - By clients in hotels, motels, and other residential type environments;
  - Bed & breakfast type environments.

**SAVE THESE INSTRUCTIONS**

**THIS APPLIANCE IS FOR HOUSEHOLD USE ONLY**

**Spectrum Brands Australia Pty Ltd**

Locked Bag 3004 Braeside  
Victoria 3195 Australia

**Customer Service in Australia**

TollFree: 1800 623 118  
Email: info@spectrumbrands.com.au  
Website: www.spectrumbrands.com.au

**Spectrum Brands New Zealand Ltd**

PO Box 9817 Newmarket  
Auckland 1149 New Zealand

**Customer Service in New Zealand**

TollFree: 0800 736 776  
Email: service@spectrumbrands.co.nz  
Website: www.spectrumbrands.co.nz

## **Spectrum Brands Australia Pty Ltd and Spectrum Brands New Zealand Ltd Warranty Against Defects**

In this warranty:

**Australian Consumer Law** means the Australian consumer law set out in Schedule 2 to the Competition and Consumer Act 2010;

**CGA** means the New Zealand Consumer Guarantees Act 1993;

**Goods** means the product or equipment which was accompanied by this warranty and purchased in Australia or New Zealand, as the case may be;

**Manufacturer, We or us** means:

1. for Goods purchased in Australia, Spectrum Brands Australia Pty Ltd ABN, 78 007 070 573;  
or
2. for Goods purchased in New Zealand, Spectrum Brands New Zealand Ltd, as the case may be, contact details as set out at the end of this warranty;

**Supplier** means the authorised distributor or retailer of the Goods that sold you the Goods in Australia or in New Zealand; and

**You** means you, the original end-user purchaser of the Goods.

1. Our goods come with guarantees that cannot be excluded under the Australian Consumer Law, or the CGA. You are entitled to a replacement or refund for a major failure and compensation for any other reasonably foreseeable loss or damage. You are also entitled to have the goods repaired or replaced if the goods fail to be of acceptable quality and the failure does not amount to a major failure.
2. The benefits provided by this Warranty are in addition to all other rights and remedies in respect of the Goods which the consumer has under either the Australian Consumer Law or the CGA. The original purchaser of the Goods is provided with the following Warranty subject to the Warranty Conditions:
3. We warrant the Goods for all parts defective in workmanship or materials for a period of 1 year from the date of purchase (**Warranty Period**).

If the Goods prove defective within the Warranty Period by reason of improper workmanship or material, we may, at our own discretion, repair or replace the Goods without charge.

## Warranty Conditions

4. The Goods must be used in accordance with the manufacturer's instructions. This Warranty does not apply should the defect in or failure of the Goods be attributable to misuse, abuse, accident or non-observance of manufacturer's instructions on the part of the user. As far as the law permits, the manufacturer does not accept liability for any direct or consequential loss, damage or other expense caused by or arising out of any failure to use the Goods in accordance with the manufacturer's instructions.
5. Exhaustible components (such as batteries, filters and brushes) of the Goods are included under this Warranty only where there is a defect in workmanship or materials used.
6. The warranty granted under clause 3 is limited to repair or replacement only.
7. Any parts of the Goods replaced during repairs or any product replaced remain the property of the manufacturer. In the event of the Goods being replaced during the Warranty Period, the warranty on the replacement Goods will expire on the same date as for the Warranty Period on the original Goods which are replaced.
8. In order to claim under the warranty granted under clause 3 you must:
  - (a) Retain this warranty with your receipt/proof of purchase; and
  - (b) Return the Goods to us at the relevant address or to the Supplier by prepaid freight within the Warranty Period accompanied with (i) the legible and unmodified original proof of purchase, which clearly indicates the name and address of the Supplier, the date and place of purchase, the product name or other product serial number and (ii) this warranty.
9. This warranty is immediately void if:
  - (a) Any serial number or appliance plate is removed or defaced;
  - (b) The Goods have been serviced or otherwise repaired by a person not authorised to do so by us or where non approved replaced parts are used.
10. The Goods are designed for domestic use only. The Goods must be connected to the electrical voltage requirements as specified in the ratings label located on the Goods.
11. This warranty does not cover the cost of claiming under the warranty or transport of the Goods to and from the Supplier or us.
12. This warranty is only valid and enforceable in Australia against Spectrum Brands Australia Pty Ltd and in New Zealand against Spectrum Brands New Zealand Ltd.

Contact us or the Supplier for further details.

## Register your product online

If you live in Australia please visit: [www.spectrumbrands.com.au/warranty](http://www.spectrumbrands.com.au/warranty)

If you live in New Zealand Please visit: [www.spectrumbrands.co.nz/warranty](http://www.spectrumbrands.co.nz/warranty)

Registration of your warranty is not compulsory, it gives us a record of your purchase AND entitles you to receive these benefits: Product information; Hints and tips; Recipes and news; Information on special price offers and promotions.



**Any questions?** Please contact Customer Service for advice.

Congratulations on the purchase of your George Foreman® HealthyCook 5-in-1 Multi Cooker. Each unit is manufactured to ensure safety and reliability.

**Before using the appliance for the first time, please read the instruction book carefully and keep it for future reference.** Pass it on if you pass on the appliance.

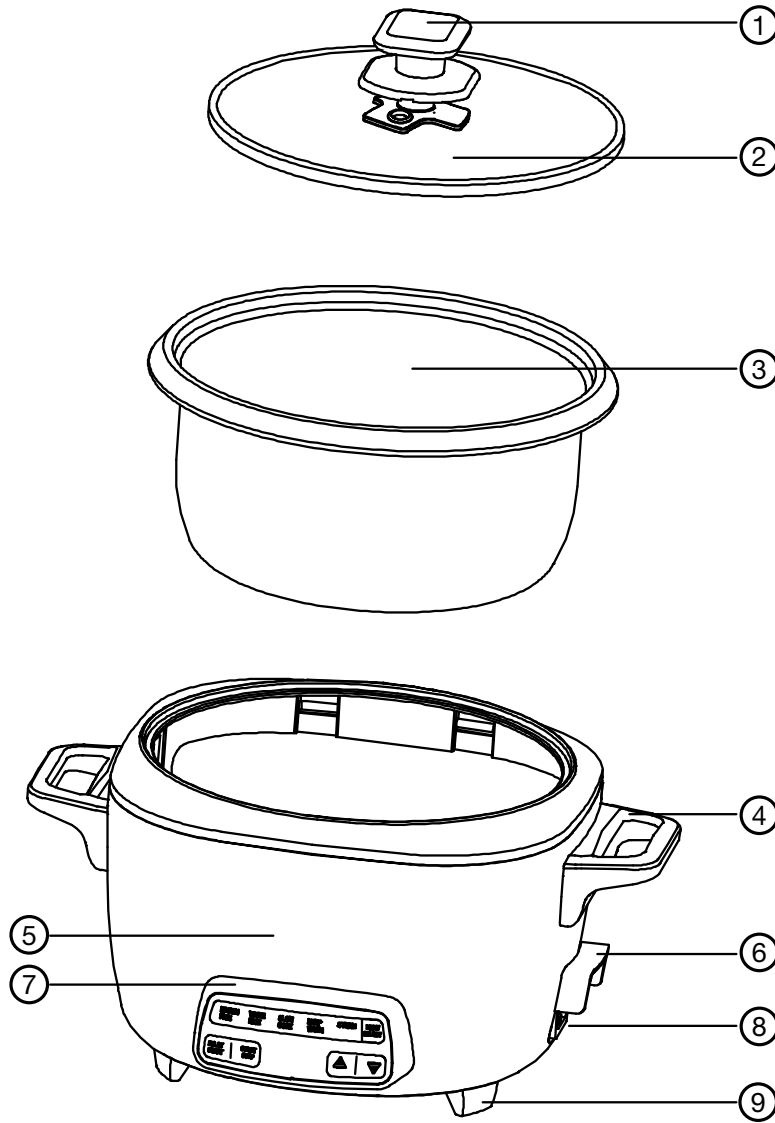
When using electrical appliances, basic safety precautions should always be followed.

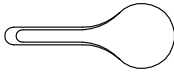

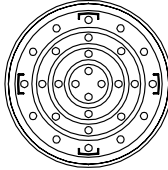
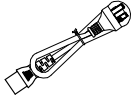
	Spatula	Measuring Cup	Steam Tray	Power Cord
Accessories				

- |                |                      |
|----------------|----------------------|
| 1. Lid handle  | 6. Protective shroud |
| 2. Glass lid   | 7. Control panel     |
| 3. Cooking pot | 8. Inlet             |
| 4. Handle      | 9. Feet              |
| 5. Housing     |                      |

## BEFORE FIRST USE

- Remove any packaging and labels from the appliance.
- As some parts may be packed separately, check to ensure all items have been unpacked before disposing of the packaging.

**CAUTION: Do not immerse the heating body of the multi cooker in water or any other liquids.**

- Dismantle and clean all removable parts as instructed in the CARE AND CLEANING section of this manual.
- Select a level, dry countertop where the appliance is to be used, allowing air space on all sides to provide sufficient ventilation and a safe distance from hot surfaces of the multi cooker.
- Ensure the multi cooker is always disconnected from the wall power outlet when not in use.

## DIRECTIONS FOR USE

Plug in the unit and switch on at the wall. 1 beep will signal the machine turning on. The unit will start in standby mode and the digital display will show “\_ \_”  
The two dashes will blink while the unit is in standby mode.

For all functions, 1 beep will signal the start of each cooking cycle.

For all functions, 2 beeps will sound when the cooking cycle is complete.

**Use Caution: when removing lid, steamer basket, pot or hot contents from this unit.**

## BROWN RICE FUNCTION

1. Press MENU SELECT until the BROWN RICE function is illuminated. The machine will set an automatic timer and the digital display will show “\_ \_”. These two dashes will blink while the unit is in standby mode.
2. Measure the rice with the supplied rice cup and add to the pot. Add water according to corresponding increments inside the pot (see diagram 1).

\*For best results, rinse uncooked rice under cold water, until the water runs clear. Then drain.

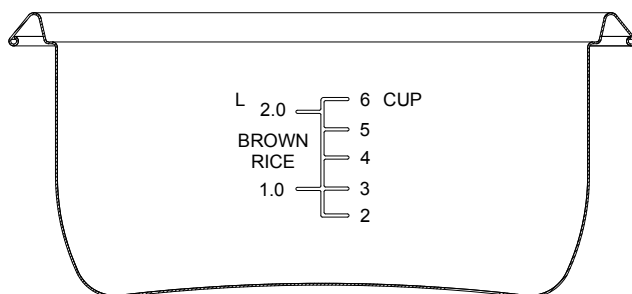

Diagram 1

**NOTE:** When cooking brown rice, add water according to the amount of cups of rice you are cooking.

E.g. if cooking 2 cups of brown rice, add the rice by using the supplied rice measuring cup, and then fill the water to the 2 cup increment on the pot.

If cooking 6 cups of brown rice, add the rice by using the supplied rice measuring cup, and then fill the water to the 6 cup increment on the pot.

3. Press the START|STOP button. 1 beep will sound to signal the start of the function. The digital display will turn around the frame while the BROWN RICE function has reached its optimum temperature. The digital display will countdown from 5 minutes during the final stage of cooking. 2 beeps will sounds when the cooking cycle is complete.

The unit will automatically switch to KEEP WARM mode. KEEP WARM mode lasts for 4 hours. After that the unit will return to standby mode. Press the START|STOP button if you need to return the unit to standby mode earlier.

## WHITE RICE FUNCTION

1. Press MENU SELECT until the WHITE RICE function is illuminated. The machine will set an automatic timer and the digital display will show “\_ \_”. These two dashes will blink while the unit is in standby mode.
2. Measure the rice with the supplied rice cup and add to the pot. Add water according to corresponding increments inside the pot (see diagram 2).

\*For best results, rinse uncooked rice under cold water, until the water runs clear. Then drain.

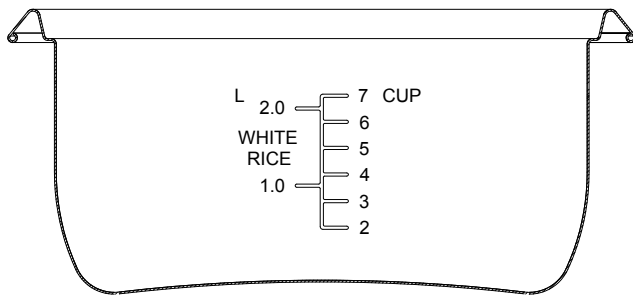

Diagram 2

**NOTE:** When cooking white rice, add water according to the amount of cups of rice you are cooking.

E.g. if cooking 2 cups of white rice, add the rice by using the supplied rice measuring cup, and then fill the water to the 2 cup increment on the pot.

If cooking 6 cups of white rice, add the rice by using the supplied rice measuring cup, and then fill the water to the 6 cup increment on the pot.

3. Press the START|STOP button. 1 beep will sound to signal the start of the function. The digital display will turn around the frame while the WHITE RICE function has reached its optimum temperature. The digital display will countdown from 5 minutes during the final stage of cooking. 2 beeps will sounds when the cooking cycle is complete.

The unit will automatically switch to KEEP WARM mode. KEEP WARM mode lasts for 4 hours. After that the unit will return to standby mode. Press the START|STOP button if you need to return the unit to standby mode earlier.

## STEAM FUNCTION

1. Press MENU SELECT until the STEAM function is illuminated. The display will show the default time of 10 minutes. Set the timer using ▲▼ (up/down) buttons; 01 to 60 minutes (maximum).
2. Add enough water to the GEORGE FOREMAN Multi-Cooker pot to reach the 1L marker. Sit the steamer basket on top. Fill the steamer basket with desired food and cover with the lid.
3. Press the START|STOP button. 1 beep will sound to signal the start of the timer. The display will count down the time while in STEAM mode. 2 beeps will sounds when the countdown is complete.



The unit will automatically switch to KEEP WARM mode. KEEP WARM mode lasts for 4 hours. After that the unit will return to standby mode. Press the START|STOP button to return the unit to standby mode.

## KEEP WARM FUNCTION

1. Press MENU SELECT until the KEEP WARM function is illuminated. The display will show the default time of 01 hour. Set the timer using ▲▼ (up/down) buttons; 01 to 04 hours (maximum).
2. Press the START|STOP button. 1 beep will sound to signal the start of the timer. The display will count down the time while in KEEP WARM mode.
3. 2 beeps will sound when the countdown is complete, and the unit will return to standby mode.

## SLOW COOK FUNCTION

1. Press MENU SELECT until the SLOW COOK function is illuminated. The display will show the default time of 06 hours. Set the timer using ▲▼ (up/down) buttons; 01 to 24 hours (maximum).
2. Press the START|STOP button. 1 beep will sound to signal the start of the timer. The timer will countdown in 1 hour increments.
3. The unit will automatically switch to KEEP WARM mode. KEEP WARM mode lasts for 4 hours. After that the unit will return to standby mode. Press the START|STOP button to return the unit to standby mode.

## DELAY START FUNCTION

1. Press MENU SELECT to select the (delayed) function you want to use. Set the timer using ▲▼ (up/down) buttons.
2. Press the DELAY START button. Set the timer using ▲▼ (up/down) buttons; 01 to 18 hours (maximum). Press the START/STOP button, 1 beep will sound to signal the start of the timer, the timer will countdown in 1 hour increments. When the delayed start timer ends, it will automatically switch to the previously selected function.
3. 2 beeps will sound when the countdown is complete, and the unit will switch to KEEP WARM for a maximum 4 hours. After 4 hours, the unit will return to standby mode.

## CARE AND CLEANING

**CAUTION: Always unplug from the wall power outlet and allow the multi cooker to cool before cleaning. Do not immerse the multi cooker heating body in water or any other liquid.**

- Before cleaning, switch off the power and remove the plug from the wall power outlet.
- Let the multi cooker cool. If the rice has cooked on to the bottom of the pot and left a 'rice crust', fill the inner pot with warm soapy water and allow it to soak for about 10 minutes before cleaning.
- Wash the pot with a sponge and dry thoroughly.
- The steamer basket and measuring cup may also be washed in warm soapy water. Rinse and dry well.
- Wipe the heating body clean with a soft, slightly damp cloth or sponge.





**GEORGE FOREMAN<sup>®</sup>**  
HEALTHY COOKING



**HealthyCook**

**RECIPES**  
**HEALTHYCOOK**  
**5-IN-1 MULTI COOKER**

**WWW.GEORGEFOREMAN.COM.AU**  
**WWW.GEORGEFOREMAN.CO.NZ**

GEORGE FOREMAN and logo are trade marks of Spectrum Brands, Inc., or one of its subsidiaries.

©2017 Spectrum Brands, Inc.

# RECIPES

WWW.GEORGEFOREMAN.COM.AU  
WWW.GEORGEFOREMAN.CO.NZ

GEORGE FOREMAN and logo are Trade Marks of Spectrum Brands, Inc., or one of its subsidiaries.  
©2017 Spectrum Brands, Inc.  
Manufactured in China to Spectrum Brands specifications.

Recipes are to be used in conjunction with the (GFMC14) George Foreman HealthyCook 5-in1 Multi Cooker.  
All rights reserved. No part of this publication may be reproduced, stored in a retrieval system or transmitted in any form or by any means, electronic, mechanical, photocopying, recording or otherwise, without prior permission of the copyright owner.

---

# RECIPES

## SPICED BASMATI PILAF

**Serves 8**

**Function:** White Rice, Slow Cook

**Preparation time:** 5 minutes

**Cooking time:** 20 minutes

### Ingredients:

1 Tablespoon mild flavoured oil, butter or ghee  
1 medium brown onion, peeled & diced  
6 cardamom pods, lightly crushed  
6 whole cloves  
1 cinnamon stick  
1 bay leaf (optional)  
2 teaspoons cumin seeds  
1 teaspoon ground turmeric  
2 cups basmati rice  
1 teaspoon salt

### Additional ingredients (optional)

1/3 cup chopped toasted nuts; such as almonds, cashews, pistachios  
1/3 cup dried fruit; such as currants, dried cranberries or diced apricot  
2 Tablespoons fresh chopped coriander leaves

### Steps:

- First cook the onion; press MENU SELECT until the SLOW COOK function is illuminated. Press the ▼ (down) button to select cooking time for 01 hour.
- Heat the oil in the pot. Add the diced onion and all the aromatic spices. Cover with the lid. Leave to cook gently for 20 minutes, or until the onions are soft and translucent. Press START|STOP to stop the machine.
- Rinse the basmati rice under cold water until the water runs clear. Drain. Add the drained rice to the GEORGE FOREMAN multi-cooker pot with enough water to reach the 2-cup fill line.
- Press MENU SELECT until the WHITE RICE function is illuminated. Cover with the lid and press START|STOP to start the machine. The digital display will flash as the rice cooks.
- When the timer sounds, carefully remove the lid and fluff the rice with the rice paddle. Return the lid and allow the rice to sit for 5 minutes.
- Discard the bay leaf, cinnamon stick, cloves and cardamom pods. Stir through the toasted nuts, dried fruit and coriander if using. Serve warm.

# RECIPES

## **BROWN SESAME RICE**

**Serves 8**

**Function:** Brown Rice

**Preparation time:** 5 minutes

**Cooking time:** 60 minutes

### **Ingredients:**

2 cups brown rice  
1 Tablespoon toasted sesame seeds  
2 teaspoons sesame oil  
2 spring onions, green ends chopped (optional)

### **Steps:**

- Rinse the rice under cold water until the water runs clear. Drain. Add the drained rice to the multi-cooker pot with a pinch of salt, and enough water to reach the 2-cup fill line.
- Press MENU SELECT until the BROWN RICE function is illuminated. Cover with the lid and press START|STOP to start the machine. The digital display will flash as the rice cooks.
- When the timer sounds, carefully remove the lid and fluff use the rice paddle. Stir through the sesame seeds, sesame oil, and chopped spring onion.

# RECIPES

## GLAZED FISH WITH STEAMED GREENS

**Serves 2**

**Function:** Steam

**Preparation time:** 35 minutes

**Cooking time:** 10 minutes

### Marinade Ingredients

1 Tablespoons soy sauce  
2 teaspoons rice wine vinegar or lime juice  
2 teaspoons clear honey  
½ teaspoon each finely grated ginger & garlic

2 x 150g firm fish fillets; such as rockling, blue-eye, barramundi or salmon  
200g green vegetables; such as broccolini, sugar snaps, edamame or green bean

### Steps:

- Combine the marinade ingredients and coat the fish fillets. Place each fillet on a square of baking paper and fold to enclose. Refrigerate 30 minutes.
- Pour 1L water into the GEORGE FOREMAN Multi-Cooker pot. Sit the steamer basket on top. Place the fish parcels and prepared vegetables inside the steamer basket.
- Press MENU SELECT until the STEAM function is illuminated. The cooking time will automatically set for 10 minutes. Cover with the lid. Press START|STOP to start the machine. Cook until the timer sounds. Carefully remove the lid and serve.

Serve with sesame rice (recipe on page 4).



# RECIPES

## CHICKEN WONTONS IN BROTH

**Serves 2**

**Function:** Steam

**Preparation time:** 20 minutes

**Cooking time:** 10 minutes

### Wontons

100g chicken mince  
2 teaspoons soy sauce  
2 teaspoons cornflour  
¼ teaspoon each finely grated ginger & garlic  
Pinch of white pepper  
12 wonton wrappers

2 cups good-quality chicken stock  
2cm piece ginger, sliced  
2 spring onions  
1 star anise  
2 teaspoons soy sauce

### Steps:

- For the wontons: Place all the ingredients except the wonton wrappers in a bowl. Mix until well combined.
- Place 1 wonton wrapper on a clean work surface. Brush the edges with water. Place 1 heaped teaspoon of chicken mixture in the centre. Fold the wonton in half to enclose the filling. Press the edges to seal. Bring the corners in and press again to seal. Repeat with remaining wrappers and chicken mixture.
- Add the stock, ginger, the white ends of spring onion, star anise to the GEORGE FOREMAN Multi-Cooker pot with 2 cups water. Sit the steamer basket on top and place the wontons inside.
- Press MENU SELECT until the STEAM function is illuminated. Press the ▼ (down) button to select the cooking time for 10 minutes. Cover with the lid and press START|STOP to start the machine.
- When the timer sounds, carefully remove the lid and check the wontons are cooked.
- Divide 6 wontons between each serving bowls. Ladle over the broth. Season with soy sauce and sprinkle with chopped green spring onion and serve.

### **Cook's Note:**

Wontons store frozen for up to 1 month. Cooking time is 15 minutes, from frozen.

# RECIPES

## CHICKEN & CHORIZO RICE

**Serves 4**

**Function:** Slow Cook

**Preparation time:** 10 minutes

**Cooking time:** 2.5 hours

### Ingredients:

1 Tablespoons olive oil  
1 red onion, peeled & diced  
1 clove garlic, crushed  
2 chicken thigh fillets, cut into 2cm pieces  
1 chorizo sausage, roughly chopped  
1½ cups risotto rice  
½ cup diced red capsicum  
1 teaspoon Spanish smoked paprika  
400g tin diced tomatoes  
handful green beans, trimmed & cut into 2cm lengths  
1/3 cup frozen peas  
salt & cracked black pepper, to taste  
fresh chopped parsley & lemon wedges, to serve

### Steps:

- Heat the olive oil in a large frying pan and add the onion and garlic. Cook until the onions are soft; about 2-3 minutes.
- Add the chicken and chorizo. Cook for a further 2-3 minutes, or until well browned. Transfer to the GEORGE FOREMAN Multi-Cooker pot with the rice, tinned tomatoes, capsicum, paprika and one tin full of water.
- Press MENU SELECT until the SLOW COOK function is illuminated. Press the ▼ (down) button to select the cooking time for 2 hours. Cover with the lid and press START|STOP to start the machine. Stir occasionally.
- When the timer sounds, carefully remove the lid and stir in the beans and peas. Cover and rest for 5 minutes.
- Season to taste. Serve with chopped parsley and lemon wedges if desired.

# RECIPES

## HEARTY VEGGIE CHILLI CON CARNE

**Serves 4-6**

**Function:** Slow Cook

**Preparation time:** 15 minutes

**Cooking time:** 6 hours

### Ingredients:

1 Tablespoon olive oil  
1 small brown onion, peeled & diced  
1 cup grated sweet potato  
½ cup diced yellow capsicum  
2 cloves garlic, crushed  
1 red chilli, deseeded & finely chopped (optional)  
1 cup red split lentils  
1½ teaspoons each ground cumin, coriander & sweet smoked paprika  
¼ teaspoon cinnamon  
1 x 400g tin crushed tomatoes  
1 x 400g tin black beans  
2 cups vegetable stock  
salt & cracked black pepper, to taste  
  
brown rice & natural yoghurt, to serve

### Steps:

- Press MENU SELECT until the SLOW COOK function is illuminated. Press the ▼ (down) button to select cooking time for 6 hours.
- Heat the oil in the GEORGE FOREMAN Multi-Cooker pot. Add the onion, capsicum, sweet potato, garlic and chilli. Stir to combine then cover with the lid and cook until the vegetables are soft, and the onion is translucent; about 10 minutes.
- Carefully remove the lid and add the lentils and all the spices. Stir well. Add the tinned tomatoes, black beans and vegetable stock. Give a final stir. Cover with the lid. Cook, stirring occasionally, until the timer sounds; the chilli con carne should be thick, and most of the liquid reduced.
- Check seasoning, and add salt and pepper to taste. Serve with brown rice and a dollop of natural yoghurt if desired.

# RECIPES

## MASSAMAN BEEF CURRY

**Serves 4-6**

**Function:** Slow Cook

**Preparation time:** 15 minutes

**Cooking time:** 6 hours

### Ingredients:

3 tablespoons peanut or coconut oil  
2 medium waxy potatoes, cut into 2cm pieces  
1 medium carrot, peeled and cut into 2cm pieces  
3 tablespoons massaman curry paste  
2cm piece fresh ginger, sliced  
1 cinnamon stick  
1 whole star anise  
600g oyster blade steak, cut into 3cm pieces  
1 large onion, peeled & sliced  
1 x 400ml can coconut cream  
1 cup beef stock  
3 tablespoons crushed roasted peanuts or peanut butter  
1 tablespoon palm sugar or soft brown sugar  
1 tablespoon fish sauce  
  
jasmine rice & lime wedges, to serve

### Steps:

- Press MENU SELECT until the SLOW COOK function is illuminated. The cooking time will automatically set to 6 hours. Press the START|STOP button to start the machine.
- Heat 1 tablespoon of oil in the GEORGE FOREMAN Multi-Cooker pot. Add the potato, carrot, massaman curry paste, ginger, cinnamon stick and star anise. Stir to combine then cover with the lid.
- Meanwhile, heat the remaining oil in a frying pan. Cook the beef in batches, until well browned. Add the onion to the pan and cook until lightly golden.
- Carefully remove the lid and add the coconut cream to the GEORGE FOREMAN Multi-Cooker pot, with the cooked beef, cooked onions, beef stock and peanuts. Cover with the lid. Cook, stirring occasionally, until the timer sounds; the beef should be tender.
- Season with brown sugar and fish sauce. Serve with jasmine rice and lime wedges if desired.