

# ASSEMBLY & OPERATING INSTRUCTIONS

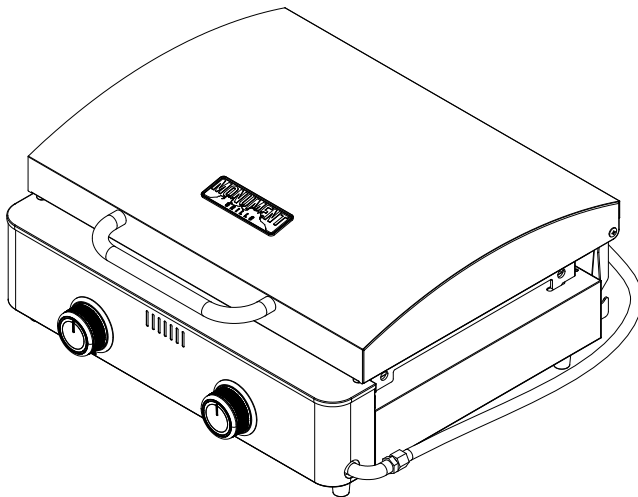

## Liquid Propane Gas Grill Griddle



Scan and visit:  
[Monumentgrills.com](http://Monumentgrills.com)



- Parts
- Assembly
- Safety Rules
- Use and Care
- Troubleshooting



### WARNING:

Read this Owner's manual carefully and be sure your gas grill is properly assembled, installed and maintained. Failure to follow these instructions could result in serious injury and/or property damage. This gas grill is intended for outdoor use only and is not intended to be installed in or on recreational vehicles or boats.

### Note to Installer

Leave this Owner's Manual with the customer after delivery and/or installation.

### Note to Consumer

Leave this Owner's Manual in a convenient place for future reference.

### Customer Service Helpline:

For parts ordering, call:  
1-800-530-9133

MFG No.: 55000(GP22TDD)

Please make sure the cylinder valve connection device shall properly and safely mate with the connection device attached to the inlet of the pressure regulator.

## Table of Contents

Warranty-----	2
Safety Precautions-----	2~4
Hardware List-----	5
Parts Diagram -----	6
Parts List-----	6
Assembly Instructions-----	7~10
Lighting Instructions-----	11~13
Cleaning and Maintenance-----	14
Troubleshooting-----	15
Cooking Instruction-----	16

## Grill Warranty

### One-Year Full Warranty on Grill

If this grill fails due to defective material or workmanship within one year from the date of purchase, call 1-800-530-9133 to arrange for a free repair (or replacement if repair proves impossible).

### 8-Year Limited Warranty on Stainless Steel Burners

For eight years from the date of purchase, any stainless-steel burner that rusts through will be replaced free of charge. After the first year from the date of purchase, you will need to pay for labor if you wish to have new burners installed for you.

All warranty coverage excludes ignitor batteries and grill part paint loss, discoloration or rusting, which are either expendable parts that can wear out from normal use within the warranty period, or are conditions that can be the result of normal use, accidents or improper maintenance,

All warranty coverage is void if this grill is ever used for commercial or rental purposes.

All warranty coverage applies only if this grill is used in North America.

This warranty provides consumers with detailed rights that apply to all residents of North America. Specific states may provide additional coverage.

The warranty is only valid for original purchasers with proof of purchase from authorized retailers. Any product bought second hand or through an unauthorized retailer, will not be covered by warranty. It is the duty of the purchaser to verify that a retailer is authorized. A purchase on Amazon or other marketplace internet retailer from any entity other than Monument Grills is not an original purchase and will not qualify for a warranty

## Safety Precautions

### **WARNING**

Combustion by products produced when using this product contain chemicals known to the State of California to cause cancer, birth defects, or other reproductive harm.

### **WARNING**

Failure to comply with these instructions could result in a fire or explosion that could cause serious bodily injury, death, or property damage.

### **WARNING**

**Your grill will get very hot.** Never lean over the cooking area while using your grill. Do not touch cooking surfaces, grill housing, lid or any other grill parts while the grill is in operation, or until the gas grill has cooled down after use.

**Failure to comply with these instructions may result in serious bodily injury.**

### **WARNING**

- 1. Do not store or use gasoline or other flammable liquids or vapors in the vicinity of this or any other appliance.**
- 2. An LP cylinder not connected for use shall not be stored in the vicinity of this or any other appliance.**

### **DANGER**

**If you smell gas:**

- 1. Shut off gas to the appliance.**
- 2. Extinguish any open flame.**
- 3. Open lid.**
- 4. If odor continues, keep away from the appliance and immediately call your gas supplier or your fire department.**

### Grill Installation Codes

The installation must conform with local codes or, in the absence of local codes, with either the national fuel gas code, ANSI Z 223.1/NFPA S4, Natural gas and propane installation code, CSA B149.1, or propane storage and handling code, B149.2, or the standard for Recreational vehicles, ANSI A 119.2, and CSA Z240 RV series recreational vehicle code, as applicable. LP gas grill models are designed for use with a standard 20 lb. Liquid Propane Gas tank, not included with grill. Never connect your gas grill to an LP gas tank that exceeds this capacity.

## Safety Precautions

A tank of approximately 12 inches in diameter by 18-1/2 inches high is the maximum size LP gas tank to use. **You must use an OPD gas tank which offers an Overfill Prevention Device.**

This safety feature prevents the tank from being overfilled which can cause malfunction of the LP gas tank, regulator and/or grill.

The LP gas tank must be constructed and marked in accordance with specifications of the U.S. Dept. of Transportation (DOT). In Canada, the LP gas tank must meet the National Standard of Canada, Can CSA –B339, Cylinders, spheres and Tubes for Transportation of Dangerous Goods and Commission.

1. The LP gas tank must have a shutoff valve, terminating in an LP gas supply tank valve outlet, that is compatible with a Type 1 tank connection device. The LP gas tank must also have a safety relief device that has a direct connection with the vapor space of the tank.
2. Always keep LP gas tanks in an upright position. The tank supply system must be arranged for vapor withdraw.
3. The LP gas tank used must have a collar to protect the tank valve.

### Proper Placement and Clearance of Grill

**Never** use your gas grill in a garage, porch, shed, breezeway or any other enclosed area. Your gas grill is to be used **outdoors only**, at least 24 inches from the back and side of any combustible surface. Your gas grill should not be used under overhead combustible construction. Do not obstruct the flow of ventilation air around the gas grill housing.

- Do not install this outdoor gas grill in or on recreational vehicles or boats
- Keep outdoor gas grill area clear and free from combustible materials, gasoline and other flammable vapors and liquids
- Do not obstruct the flow of combustion and ventilation air. Check for this each time prior to using grill.
- **Never** connect an unregulated LP gas tank to your gas grill. The gas regulator assembly supplied with your gas grill is adjusted to have an outlet pressure of 11" water column (W.C.) for connection to an LP gas tank.
- Only use the regulator and the hose assembly supplied with your gas grill. Replacement regulators and hose assemblies must be those specified in this manual.

- Have your LP gas tank filled by a reputable propane gas dealer and visually inspected and re-qualified at each filling.
- Do not store a spare LP gas tank under or
- Never fill the tank beyond 80 percent full. If this information is not followed exactly a fire causing death or serious injury may occur.
- Always keep LP gas tanks in an upright position.
- Do not store (or) or use gasoline or other flammable vapors and liquids in the vicinity of this gas grill.
- Do not subject the LP gas tank to excessive heat.
- Never store an LP gas tank indoors. If you store your gas grill in the garage or other indoor location, **always** disconnect the LP gas tank first and store it safely outside.



- Place dust cap on cylinder valve outlet whenever the cylinder is not in use. Only install the type of dust cap on the cylinder valve outlet that is provided with the cylinder valve. Other types of caps or plugs may result in leakage of propane.
- LP gas tanks must be stored outdoors in a well-ventilated area and out of reach of children. Disconnected LP gas tanks must not be stored in a building, garage or any other enclosed area.
- When your gas grill is not in use the gas must be turned off at the LP gas tank.
- The pressure regulator and hose assembly must be inspected before each use of the grill. If there is excessive abrasion or wear or if the hose is cut, it must be replaced prior to the grill being used again.
- Keep the gas regulator hose away from hot grill surfaces and dripping grease. Avoid unnecessary twisting of hose. Visually inspect the hose prior to each use for cuts, cracks, excessive wear or other damage. If the hose appears damaged do not use the gas grill.
- **Never** light your gas grill with the lid closed or before checking to ensure the burner tubes are fully seated over the gas valve orifices.
- **Never** allow children to operate your grill.

**⚠ WARNING**

A strong gas smell, or the hissing sound of gas indicates a serious problem with your gas grill or the LP gas tank. Failure to immediately follow the steps listed below could result in a fire or explosion that could cause serious bodily injury, death, or property damage.

- Shut off gas supply to the gas grill.
- Turn the control knobs to OFF position.
- Put out any flame with a proper fire extinguisher.
- Open Grill Lid.
- Get away from the LP gas tank.
- Do not try to fix the problem yourself.
- If odor continues or you have a fire you can not extinguish, call your fire department. Do not call near the LP gas tank because your telephone is a form of electrical device and could create a spark resulting in fire and/or explosion.

**NOTE:** The normal flow of gas through the regulator and hose assembly can create a humming noise. A low volume of noise is perfectly normal and will not interfere with operation of the grill. If humming noise is loud and excessive you may need to purge air from the gas line or reset the regulator excess gas flow device. This purging procedure should be done every time a new LP gas tank is connected to your grill.

**Burner Flame Check**

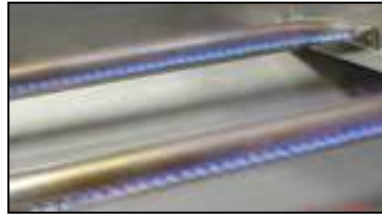

Visually check the burner flames prior to each use. The flames should look like the picture above. If they do not, refer to the *Cleaning Burner Tubes* and *Burner Ports* instructions in this manual.

**⚠ WARNING**

Pls ensure cleaning the flame tamer/cooking grid/grease pan/tray after each use. Failure to comply this could result in a fire or explosion that could cause serious bodily injury, death, or property damage.

**CAUTION: Beware of Flash-Back**



**CAUTION:** Spiders and small insects occasionally spin webs or make nests in the grill burner tubes during transit and warehousing. These webs can lead to gas flow obstruction which could result in a fire in and around burner tubes. This type of fire is known as "FLASH-BACK" and can cause serious damage to your grill and create an unsafe operating condition for the user.

Although an obstructed burner tube is not the only cause of "FLASH-BACK", it is the most common cause.

To reduce the chance of "FLASH-BACK", you must clean the burner tubes before assembling your grill, and at least once a month in late summer or early fall when spiders are most active. Also perform this burner tube cleaning procedure if your grill has not been used for an extended period of time.

## Contents for Hardware Pack

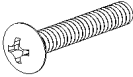
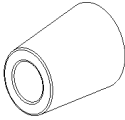
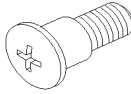
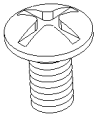
The following table illustrates a breakdown of the hardware pack. It highlights what components are used in the various stages of assembly.

A		5/32"x30	4pcs
B			4pcs
C		1/4"	2pcs
D		1/4"x14	2pcs
E		ST4.2x9	2pcs
F		5/32"x12	4pcs

### Tools required for assembly

Philips Head Screwdriver (not included).

Note: The left and right sides of the grill are on your left and right as you face the front of the grill.

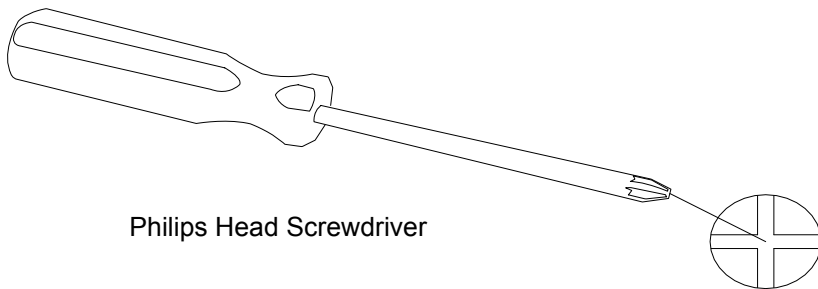

Philips Head Screwdriver

## Model 55000 Parts Diagram

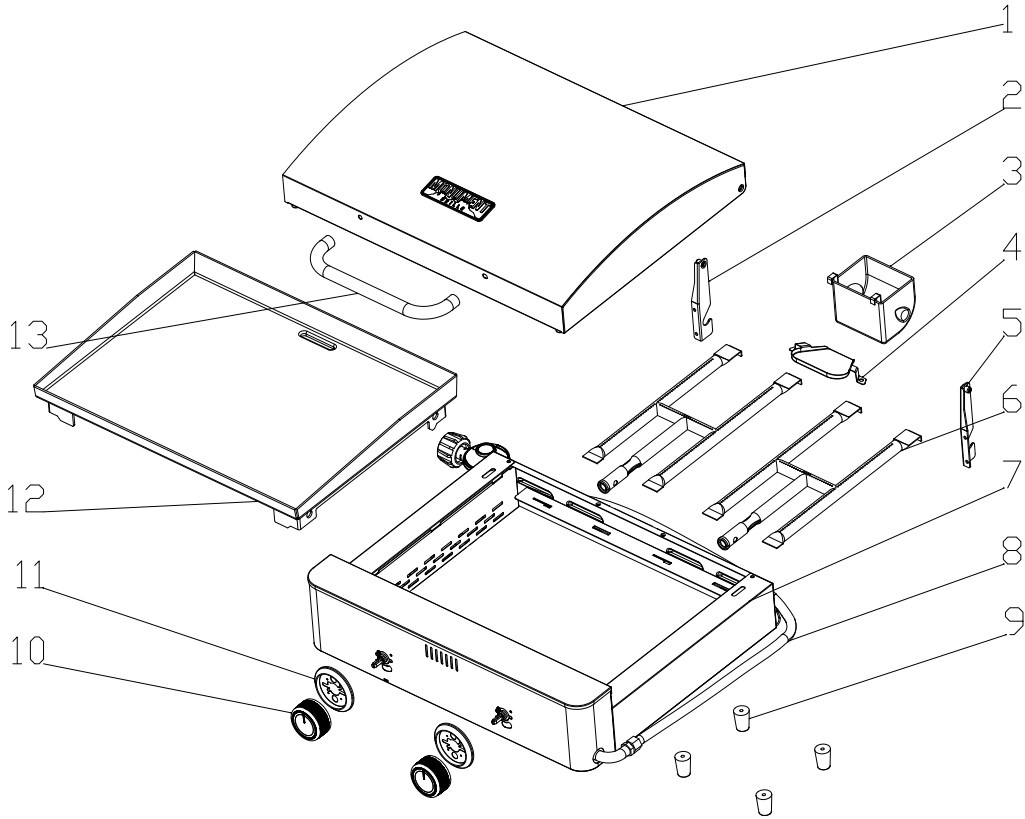

### Model 55000 Parts List

Seq. NO.	Material code	Appellation	Qty
1	D30X003365	Main Lid	1
2	A02121931	Lid Supporter , Left	1
3	A0212497	Grease Box	1
4	D30M000607	Oil Drain	1
5	A02121932	Lid Supporter , Right	1
6	A02121943	Main Burner	2
7	D30X003366	Firebox Assembly	1
8	A02120851	Regulator	1
9	A0206080	Feet	4
10	A02120817	Control Knob	2
11	D010013934	Control Knob Base	2
12	A02121925	Gas Griddle	1
13	A02120143	Main Lid Handle	1

Important: Use only parts listed above. When ordering parts, providing the following information:

- Model #  
 1. Part Number (see PART# in chart)  
 2. Part Description  
 3. Quantity of parts needed

# Assembly Instructions

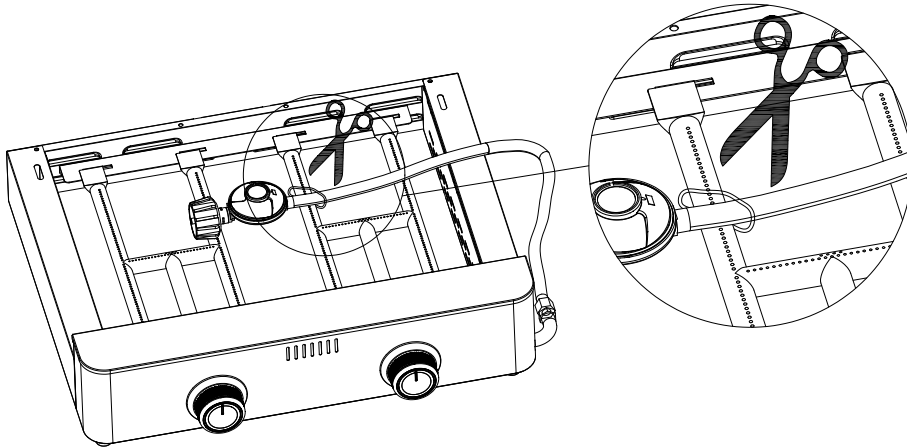

## STEP 1

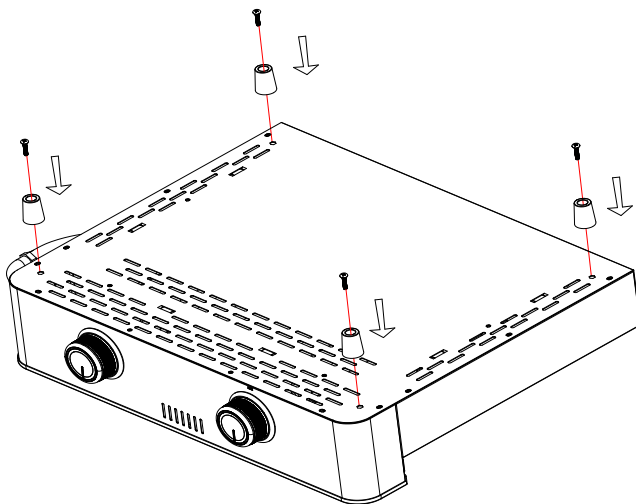

cut off the nylon ties as per the illustration

## STEP 2



- A  x4
- B  x4

Screw the feet into the grill bottom

### STEP 3

E  x2

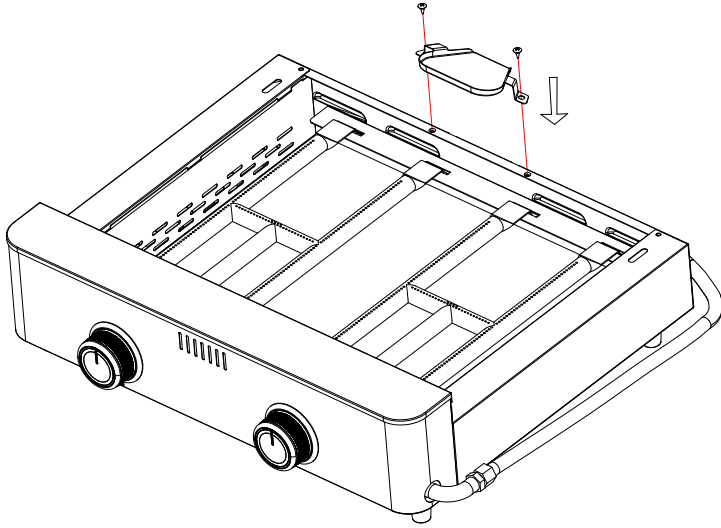

Screw Part No.4 into the grill location as shown

### STEP 4

F  x4

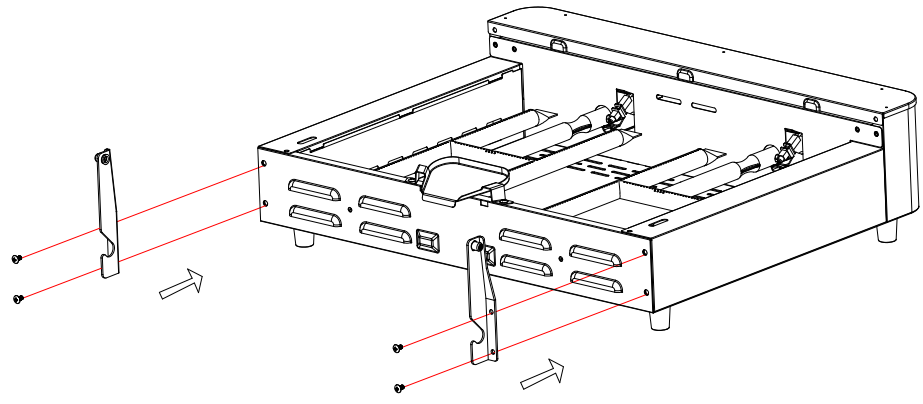

Screw Parts No.2 & No.5 into the grill as shown



STEP 5

D  x2

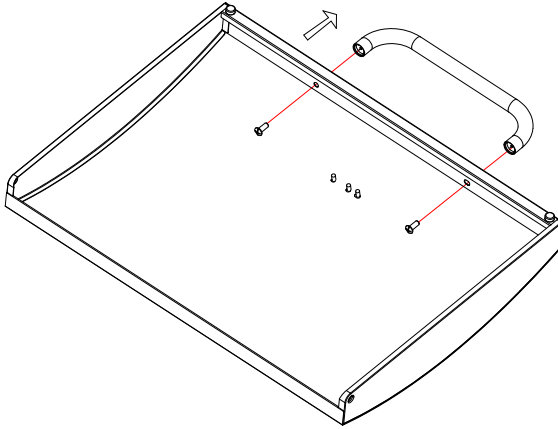

Install the handle onto the main lid

STEP 6

C  x2

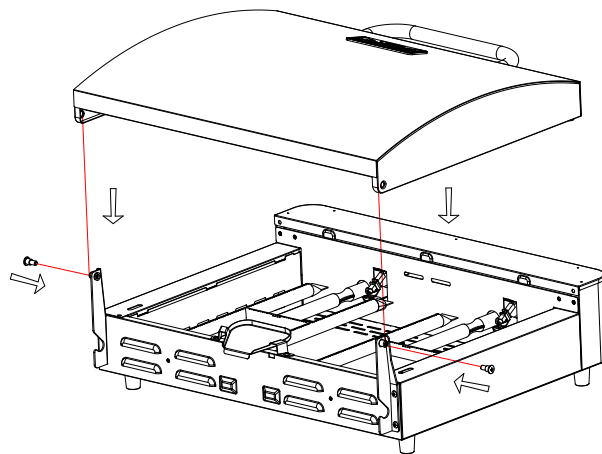

Install the main lid onto the grill body

STEP 7

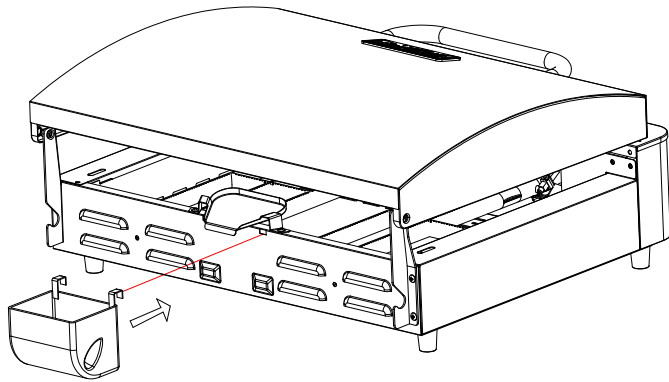

Install the Part No.3 onto the grill body

STEP 8

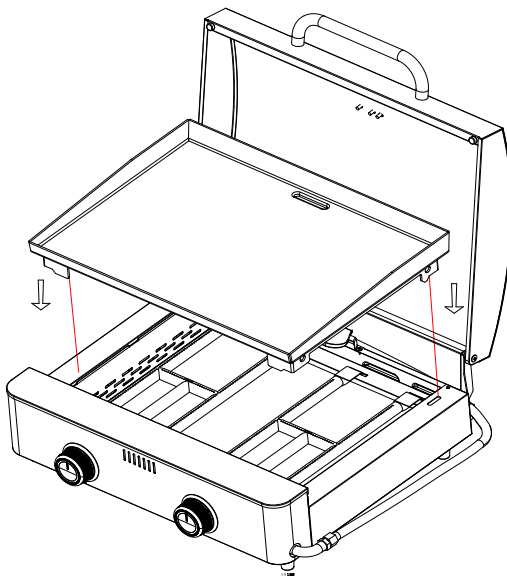

Put the griddle top onto the grill body

### Connecting LP Gas Tank to LP Grill

1. Place foot ring of 20 lb. tank into the hole in bottom panel. Make sure the tank valve is in OFF position.
2. Check the tank valve to ensure it has proper external mating threads to fit the hose and regulator assembly provided.
3. Make sure all burner valves are in OFF position.
4. Inspect the valve connection port and regulator assembly. Look for damage or debris. Remove any debris. Inspect hose for damage. Never use damaged or plugged equipment.
5. When connecting regulator and hose assembly to tank valve, hand tighten quick coupling nut clockwise to a full stop, Do not use a wrench to tighten because it could damage the quick coupling nut and result in a hazardous condition.
6. Open tank valve fully (counterclockwise). Use a soapy water solution to check all connections for leaks before attempting to light your grill. If a leak is found, turn tank valve off and do not use your grill until the leak is repaired.

**CAUTION:** When the appliance is not in use, gas must be turned off at the supply tank.

### Regulator Connection

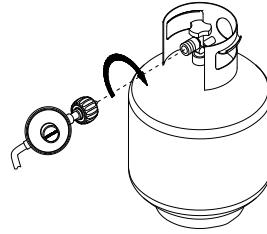

### Congratulations

Your gas grill is now ready for use. Before the first use and at the beginning of each season (and whenever the LP gas tank has been changed):

1. Read all safety, lighting and operating instructions.
2. Check gas valve orifices, burner tubes and burner ports for any obstructions.
3. Perform gas leak check according to instructions found on next page of the manual.

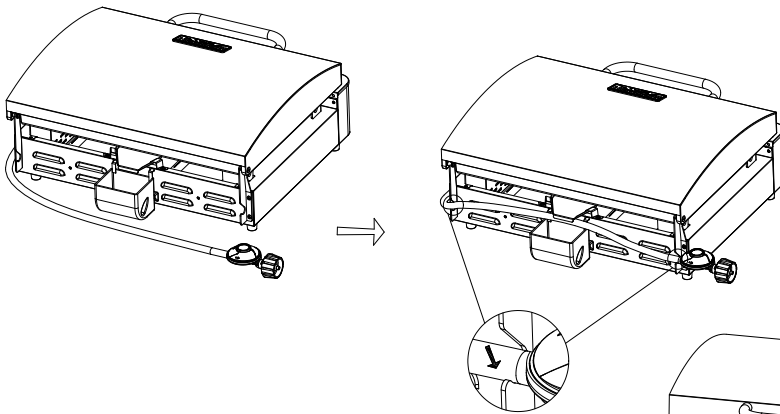

Hang the regulator hose on the hook as the illustration after grilling

The distance between tabletop and propane tank must be 10" min and 24" max (Note that this is not the actual hose length)

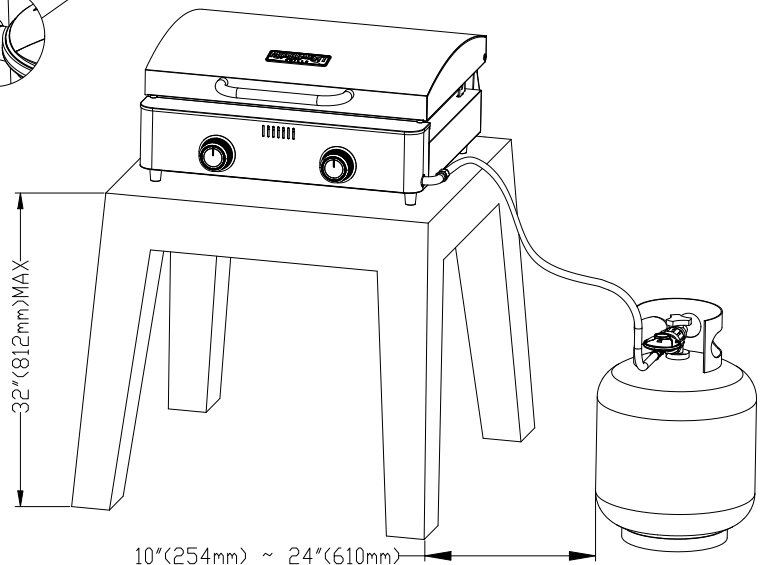

## Checking for LP gas leaks

Never test for leaks with a flame. Prior to first use, at the beginning of each season, or every time your LP gas tank is changed, you must check for gas leaks.

1. Make a 50/50 (soap/water) mild soap solution.
2. Turn the control knobs to full OFF position; then turn gas ON at supply tank.
3. Apply the soap solution with a clean brush to all gas connections. See below. If growing bubbles appear in the solution the connections are not properly sealed. Check each fitting and tighten or repair, as necessary.

### Gas Connection Leak Check



4. If you have a gas connection leak you cannot repair, turn gas OFF at supply tank, disconnect fuel line from your grill and call your gas supplier for repair assistance.
5. Also apply soapy solution to the tank seams. See below. If growing bubbles appear, shut tank OFF and do not use or move it! Contact an LP gas supplier or your fire department for assistance.

### Gas Tank Leak Check

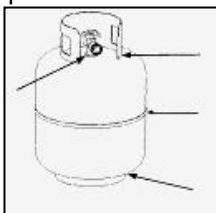

7. To light burners, push and turn burner knob (s) to IGNITE/Hi. At the same time, press and hold electronic ignition button for 3 to 5 seconds to light burner. Adjust knob (s) to desired setting.
8. If the burner does not light after 5 seconds, turn knob to OFF. Turn gas OFF at LP tank and wait 5 minutes for gas to clear. Then turn gas ON at tank and repeat step 6.
9. If burner still does not light, see Match Lighting section and If Grill Still Fails to Light section on following page.

## Grill Lighting Instruction

### Grill Lighting Instructions for Main Burners

1. Do not smoke while lighting grill or checking gas supply connections.
2. Be sure that LP gas tank is sufficiently full.
3. Be sure all gas connections are securely tightened.
4. Turn on gas supply
5. Open the grill main lid and side burner lid.
6. Push and turn any main burner knob to IGNITE/Hi position, at the same time, press and hold electronic ignition button for 3 to 5 seconds to light burner.



### WARNING

Failure to open grill lid during the lighting procedure could result in a fire or explosion that could cause serious bodily injury, death, or property damage.



## WARNING

**Never** lean over the grill cooking area while lighting your gas grill. Keep your face and body a safe distance (at least 18 inches) from the cooking grid surface when lighting your grill by match.

### Manually Lighting Your Grill by Match

1. Take the manual lighting stick
2. Insert a match into the lighting stick.
3. Follow steps 1 through 5 of the Basic Lighting Procedure.
4. Light the match and extend the lighting stick to cooking grid surface.
5. Turn the desired control knob to the HI/position setting to release gas. The burner should light immediately.



## WARNING

**Should a “FLASH-BACK” fire occur in/or around the burner tubes, follow the instructions below. Failure to comply with these instructions could result in a fire or explosion that could cause serious bodily injury, death, or property damage.**

- Shut off gas supply to the gas grill.
- Turn the control knobs to OFF position.
- Put out any flame with a proper fire extinguisher.
- Open grill lid.
- Once the grill has cooled down, clean the burner tubes and burners according to the cleaning instructions

### If Grill Still Fails To Light

1. Check gas supply and connections for leaks. Check that all wire connections are secure.

2. Repeat basic lighting procedure. If your grill still fails to operate, turn the gas off at source, turn the control knobs to OFF, then check the following:

- Misalignment of burner tubes over orifices

**Correction:** Reposition burner tubes over orifices.

- Obstruction in gas line

**Correction:** Remove fuel line from grill. Do not smoke! Open gas supply for 1 second to clear any obstruction from fuel line. Close off gas supply at source and reconnect fuel line to grill.

- Plugged orifice

**Correction:** Remove burners from grill, carefully lift each burner up and away from gas valve orifice. Remove the orifice from gas valve and gently clear any obstruction with a fine wire. Then reinstall all orifices, burners, and cooking components.

3. If an obstruction is suspected in gas valves, please call for repair service at 1-800-530-9133

4. If the grill still does not light you may need to purge air from the gas line or reset the regulator excess gas flow device. **Note:** This procedure should be done every time a new LP gas tank is connected to your grill.

### To purge air from your gas line and/or reset the regulator excess gas flow device:

- Turn the control knob to OFF position.
- Turn off the gas at the tank valve.
- Disconnect regulator from LP gas tank.
- Let unit stand for 5 minutes.
- Reconnect regulator to the LP gas tank.
- Turn the tank valve on slowly until  $\frac{1}{4}$  to  $\frac{1}{2}$  open.
- Open the grill lid.
- Set control knobs to OFF. Push and turn any control knob to HIGH.
- Turn control knobs to HIGH until all the burners are lit
- You may start to use the grill

5. If all checks or corrections have been made and you still have questions about operating your gas grill, call the **Customer Service Helpline**

## Cleaning and Maintenance

To ensure a proper working unit the following proper care and maintenance is suggested.

### Cleaning Cooking Griddles

We suggest you wash your cooking grids in a mild soap and warm water solution. You can use a washcloth or soft brush to clean your cooking grids.

### Cleaning Heat Diffusers

Periodically you should wash the heat diffusers in a soap and warm water solution. Use a soft brush to remove stubborn burnt-on cooking residue. The heat diffusers should be dry before you reinstall them.

### Cleaning Grease Tray

The grease tray should be emptied and wiped down periodically and washed in a mild detergent and warm water solution. A small amount of sand or cat litter may be placed in bottom of grease tray to absorb the grease. Check the grease tray frequently, don't allow excess grease to accumulate and overflow out of the grease tray.

### Annual Cleaning of Grill Interior

Burning-off the grill after each cook will keep it ready for your next use. However, once a year you should give the entire grill a thorough cleaning to keep it in top operating condition. Follow these steps.

1. Turn all burner valves to full OFF position.
2. Turn LP gas tank valve to full OFF position.
3. Detach LP gas hose and regulator assembly from your gas grill. Inspect for any damage and replace as necessary with manufacturer replacement part number found on parts list.
4. Remove and clean heat diffusers, cooking grids and grill burners.
5. Cover each gas valve orifice with aluminum foil.
6. Brush inside and bottom of grill with a nylon brush, and wash with a mild soap and warm water solution. Rinse thoroughly and let dry.
7. Remove the aluminum foil, then reinstall heat diffusers, and cooking grids.
8. Reconnect gas source and observe burner flame for correct operation.

### Cleaning Exterior Surface

•We suggest you wash your grill using a mild soap and warm water solution. You can use a wash cloth or sponge for this process. Do not use abrasives or a brush that might remove finish during the cleaning process.

### Cleaning Exterior Stainless Steel Surfaces

•Weathering and extreme heat can cause exterior stainless-steel surfaces to turn tan in color. Machine oils used in manufacturing process of stainless steel can also cause this tanning color. Use a stainless-steel cleaner to polish all stainless-steel surfaces on your grill. Never use abrasive cleaners or scrubbers because they will scratch and damage your grill.

### Cleaning Burner Tubes and Burner Ports

To reduce the chance of "FLASH-BACK" the procedure below should be followed at least once a month in late summer or early fall when spiders are most active or when your grill has not been used for a period of time.

1. Turn all burner valves and gas tank valve to off position.
2. Detach the LP gas regulator assembly from your gas grill.
3. Remove cooking grids, heat diffusers, and grease tray from the grill.
4. Remove the screws from the underside of each burner and lift the burners up and away from the gas valve orifice.
5. Using a bent stiff wire in the shape of a hook, air hose or a bottle brush, run it through the burner tube and inside several times to remove any debris.
6. Replace burners, see illustration below.

Step 1



Step 2



Step 3



### WARNING

The location of the burner tube with respect to the orifice is vital for safe operation. Check to ensure the orifice is inside the burner tube before using the gas grill. If the burner tube does not fit over the valve orifice, lighting the burner may cause explosion and/or fire.

Regardless of which burner cleaning procedure you use, we recommend you also complete the following steps to help prolong burner life.

1. Use a fiber pad or nylon brush to clean the entire outer surface of each burner until free of food residue and dirt.
2. Clean any clogged ports with a stiff wire, such as an open paper clip.

3. Inspect each burner for damage (cracks or holes) and if such damage is found, order and install a new burner. After installation check to ensure that gas valve orifices are correctly placed inside the ends of the burner tubes.

 **WARNING**

Spiders and insects can nest inside the burners of the grill and disrupt gas flow. This very dangerous condition could cause a fire behind the valve panel, thereby damaging the grill and making it unsafe for operation. Inspect the grill at least twice a year.

## Troubleshooting

### BEFORE CALLING FOR SERVICE

If the grill does not function properly, use the following check list before calling for service.

You should inspect the burners at least once a year or immediately after any of the following conditions occur:

PROBLEMS	WHAT TO DO
Grill won't light when the control knob is rotated.	<p>Check to see if LP tank is empty.</p> <p>Clean wires and/or electrode by rubbing with alcohol and clean swab.</p> <p>Wipe with dry cloth.</p> <p>Make sure the wire is connected to electrode assembly.</p> <p>Do other burners on the unit operate?</p> <p>Check to see if other burners operate. If so, check the gas orifice on the malfunctioning burner for an obstruction.</p>
Burner flame is yellow or orange, in combination with the odor of gas.	Refer to Clean Burner Tubes and Burner Ports.
Low heat with knob in "HI" position.	<p>Is the fuel hose bent or kinked?</p> <p>Is the grill in a dusty area?</p> <p>Is there adequate gas supply available?</p> <p>If it is only one burner that appears low, does the orifice or burner need cleaning?</p> <p>Is the gas supply or gas pressure low?</p>



## Cooking Instructions

### WARNING

**Do not leave the grill unattended. Your grill will get very hot.** Never lean over the cooking area while using your grill. Do not touch cooking surfaces, grill housing, Grill Lid or any other grill parts while the grill is in operation, or until the grill has cooled down after use. Failure to comply with these instructions may result in serious bodily injury.

#### Burn-off

Before cooking on your gas grill for the first time, you will want to “burn off” the grill to eliminate any odor or foreign matter. Just ignite the burners, lower the lid, and operate grill on the HIGH setting for 3 to 5 minutes.

#### Cooking Temperatures

**High setting:** Only use this setting for fast warm-up, searing steaks or chops and for burning food residue off the grill after cooking is complete. **Never** use the HIGH setting for extended cooking.

**Medium to Low Settings:** Most recipes specify medium to low settings, including all smoking and for cooking lean cuts such as fish.

**NOTE:** Temperature settings will vary with the temperature and the amount of wind outside your home.

#### Direct Cooking

The direct cooking method can be used with the supplied cooking grids and food placed directly over the lit grill burners. **Direct cooking requires the grill lid to be up.** The method is ideal for searing, grilling and smoking or whenever you want meat, poultry or fish to have an open-flame barbecued taste.

### WARNING

Do not line the bottom of the grill housing with aluminum foil, sand or any substance that will restrict the flow of grease into the grease tray. Failure to comply with these instructions could result in a fire or explosion which could cause serious bodily injury, death, or property damage.

#### Indirect Cooking

To cook **indirectly**, the food should be placed on the left or right side of your grill with the burner lit on the opposite side. **Indirect cooking must be done with the lid down.**

#### Flare-ups

The fats and juices dripping from grilled food can cause flare-ups. Since flare-ups impart a favorable, distinctive taste and color to food cooked over an open flame, they should be accepted up to a point. Nevertheless, uncontrolled flaring can result in a ruined meal.

#### Correct Disposal of this product

This marking indicates that this product should not be disposed with other household wastes throughout the EU. To prevent possible harm to the environment or human health from uncontrolled waste disposal, recycle it responsibly to promote the sustainable reuse of material resources. To return your used device, please use the return and collection systems or contact the retailer where the product was purchased. They can take this product for environmentally safe recycling.

