

shop.vac®

Mod. SEP16-600C

SEP SERIES

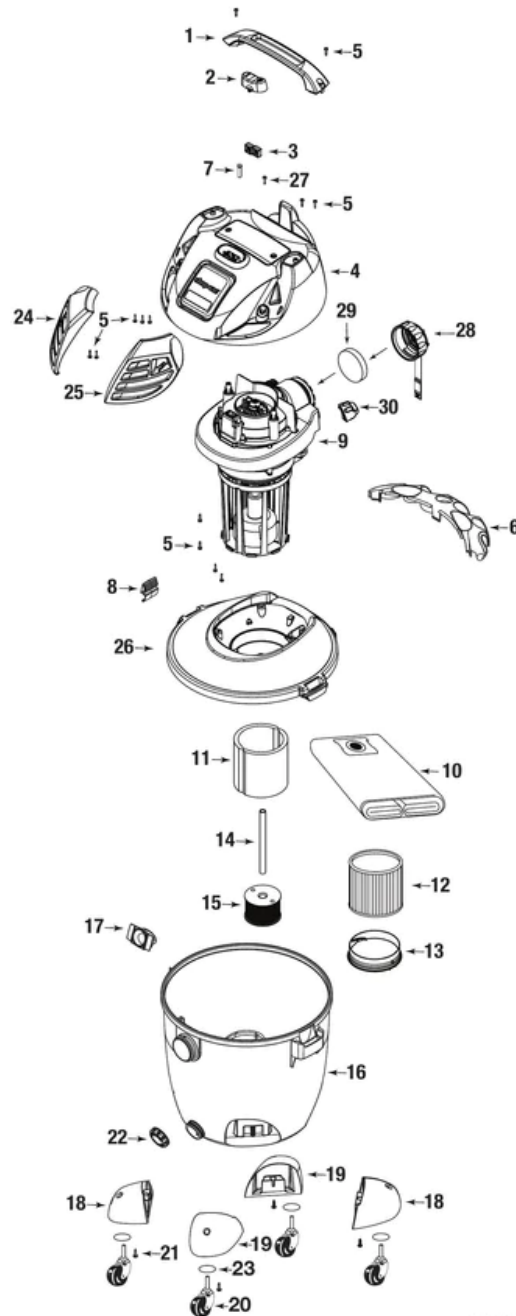

ITEM	DESCRIPTION	PART NO.
1	Handle	3756406
2	Switch Rocker	8230421
3	Switch Extension	7414254
4	Motor Cover Assembly (Includes 5, 24, 25 & 27)	2433590
5	Screw 10 x 3/4" Trilobe Twin Lead	1517699
6	Tool Holder	8412000
7	Switch Actuator	2431215
8	Lid Latch	7444501
9	Power Unit Assembly	8310297
10	Collection Bag	90662
11	Foam Sleeve	90585
12	Cartridge Filter	9034411
13	Filter Retainer	3008000
14	Pickup Tube	2723104
15	Pickup Cage Assembly	7412250
16	Tank Assembly	1944838
17	Inlet Deflector	7413120
18	Caster Foot A	8568006
19	Caster Foot B	8568016
20	Caster	6773900
21	Screw 10 x 3/4" SL Hex Head	1503999
22	Drain Cap	7446803
23	Flat washer	0704399
24	Left Grill	2433536
25	Right Grill	2433526
26	Lid Cage	3188161
27	Screw	2783205
28	Blower Port Cap (Includes 29)	1945188
29	Foam Diffuser	1290530
30	Pump Out Cap	1945023

*Replacement parts may differ from original equipment.

SV5825411 Rev 08/15