

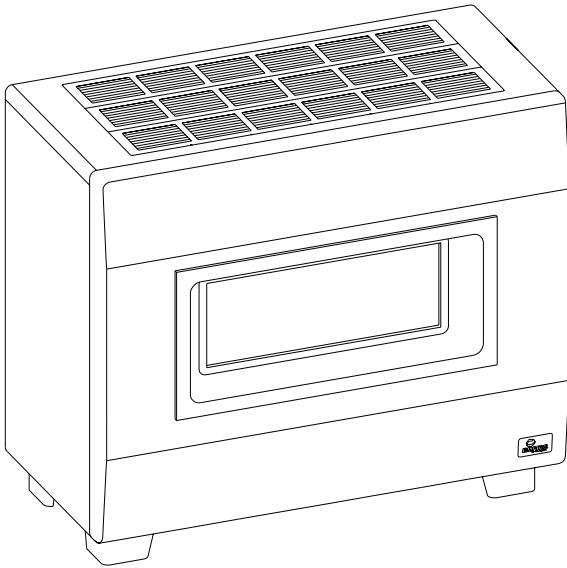

# INSTALLATION INSTRUCTIONS AND OWNER'S MANUAL



## VENTED VISUAL FLAME ROOM HEATER

MODELS  
RH-50-5  
RH-65-5

**WARNING:** If the information in this manual is not followed exactly, a fire or explosion may result causing property damage, personal injury or loss of life.



EFFECTIVE DATE  
AUGUST, 2000

- Do not store or use gasoline or other flammable vapors and liquids in the vicinity of this or any other appliance.
- WHAT TO DO IF YOU SMELL GAS
  - Do not try to light any appliance.
  - Do not touch any electrical switch; do not use any phone in your building.
  - Immediately call your gas supplier from a neighbor's phone. Follow the gas supplier's instructions.
  - If you cannot reach your gas supplier, call the fire department.
- Installation and service must be performed by a qualified installer, service agency or the gas supplier.

**WARNING:** If not installed, operated and maintained in accordance with the manufacturer's instructions, this product could expose you to substances in fuel or from fuel combustion which can cause death or serious illness.

## Introduction

Always consult your local Building Department regarding regulations, codes or ordinances which apply to the installation of a vented room heater.

## Instructions to Installer

1. Installer must leave instruction manual with owner after installation.
2. Installer must have owner fill out and mail warranty card supplied with heater.
3. Installer should show owner how to start and operate heater and thermostat.

### Warning:

**Any change to this room heater or its controls can be dangerous. Any safety screen or guard removed for servicing a room heater must be replaced prior to operating the room heater.**

## General Information

This series is design certified in accordance with American National Standard / CSA Standard Z21.86b-1998 and CSA 2.32b-M98 by the American Gas Association and Canadian Gas Association, as a Vented Room Heater and must be installed according to these instructions.

**Any alteration of the original design, installed other than as shown in these instructions or use with a type of gas not shown on the rating plate is the responsibility of the person and company making the change.**

## Important

All correspondence should refer to complete Model No., Serial No. and type of gas.

**Notice:** During initial firing of this unit, its paint will bake out and smoke will occur. To prevent triggering of smoke alarms, ventilate the room in which the unit is installed.

## Installation on Rugs and Tile

If this appliance is to be installed directly on carpeting, tile, or other combustible material, *other than wood flooring*, the appliance shall be installed on a metal or wood panel extending the full width and depth of the appliance.

The base referred to above does not mean the fire-proof base as used on wood stoves. The protection is primarily for rugs that may be extremely thick and light-color tile that can discolor.

Heater pad is available from Empire Comfort Systems, Inc., Part No. RH-425.

## Specifications

| Models   | RH-50-5          | RH-65-5           |
|--|------------------|-------------------|
| Input BTU/HR (KW/H)  | 50,000 (14.6)    | 65,000 (19)       |
| Height   | 29 9/16" (751mm) | 29 9/16" (751mm)  |
| Width  | 34" (864mm)      | 34" (864mm)       |
| Depth including diverter   | 23 3/16" (589mm) | 27 11/16" (704mm) |
| Gas Inlet  | 1/2" (13mm)      | 1/2" (13mm)       |
| Size Draft Diverter Collar   | 5 " (127mm)      | 5 " (127mm)       |
| Floor to top of collar on vertical position of Draft Diverter      | 27 5/32" (690mm) | 27 5/32" (690mm)  |
| Floor to center of collar on horizontal position of Draft Diverter | 22 9/16" (573mm) | 22 9/16" (573mm)  |
| <b>Accessories</b>   |                  |                   |
| Blower Package   | FRB-3            | FRB-3             |
| Radiant Package  | RAD-8            | RAD-8             |
| Heater Pad   | RH-425           | RH-425            |
| Ceramic Log  | RHL-1            | RHL-1             |

# THIS IS A HEATING APPLIANCE

DO NOT OPERATE THIS APPLIANCE WITHOUT FRONT PANEL INSTALLED.

- Due to high temperatures, the room heater should be located out of traffic and away from furniture and draperies.
- Children and adults should be alerted to the hazards of high surface temperature and should stay away to avoid burns or clothing ignition.
- Young children should be carefully supervised when they are in the same room as the room heater.
- Clothing or other flammable material should not be placed on or near the room heater.
- Due to high surface temperatures, keep children, clothing and furniture away.
- Keep burner and control compartment clean.
- Installation and repair should be done by a **QUALIFIED SERVICE PERSON**. The room heater should be inspected before use and at least annually by a qualified service person. More frequent cleaning may be required due to excessive lint from carpeting, bedding material,

etc. It is imperative that control compartments, burners and circulating air passageways of the room heater be kept clean.

- **DO NOT** put anything around the heater that will obstruct the flow of combustion and ventilation air. See clearances.
- **DO** keep the appliance area clear and free from combustible material, gasoline and other flammable vapors and liquids.
- **DO** examine venting system periodically. Clean and replace damaged parts. Examinations should be made at the start of the heating season and also in mid heating season under average conditions.
- **DO** examine burners periodically. Clean and replace damaged parts.
- **DO NOT** use this heater if any part has been under water. Immediately call a qualified service technician to inspect the heater and to replace any part of the control system and any gas control which has been under water.

## SAFETY INFORMATION FOR USERS OF LP-GAS

Propane (LP-Gas) is a flammable gas which can cause fires and explosions. In its natural state, propane is odorless and colorless. You may not know all the following safety precautions which can protect both you and your family from an accident. Read them carefully now, then review them point

by point with the members of your household. Someday when there may not be a minute to lose, everyone's safety will depend on knowing exactly what to do. If, after reading the following information, you feel you still need more information, please contact your gas supplier.

### LP-GAS WARNING ODOR

If a gas leak happens, you should be able to smell the gas because of the odorant put in the LP-Gas.

That's your signal to go into immediate action!

- Do not operate electric switches, light matches, use your phone. Do not do anything that could ignite the gas.
- Get everyone out of the building, vehicle, trailer, or area. Do that IMMEDIATELY.
- Close all gas tank or cylinder supply valves.
- LP-Gas is heavier than air and may settle in low areas such as basements. When you have reason to suspect a gas leak, keep out of basements and other low areas. Stay out until firefighters declare them to be safe.
- Use your neighbor's phone and call a trained LP-Gas service person and the fire department. Even though you may not continue to smell gas, do not turn on the gas again. Do not re-enter the building, vehicle, trailer, or area.
- **Finally**, let the service man and firefighters check for escaped gas. Have them air out the area before you return. Properly trained LP-Gas service people should repair the leak, then check and relight the gas appliance for you.

### NO ODOR DETECTED - ODOR FADE

Some people cannot smell well. Some people cannot smell the odor of the chemical stench put into the gas. You must find out if you can smell the odorant in propane. Smoking can decrease your ability to smell. Being around an odor for a time can affect your sensitivity or ability to detect that odor. Sometimes other odors in the area mask the gas odor. People may not smell the gas odor or their minds are on something else. Thinking about smelling a gas odor can make it easier to smell.

The odorant in LP-gas is colorless, and it can fade under some circumstances. For example, if there is an underground leak, the movement of the gas through soil can filter the odorant. Odorants in LP-Gas also are subject to oxidation. This fading can

occur if there is rust inside the storage tank or in iron gas pipes.

The odorant in escaped gas can adsorb or absorb onto or into walls, masonry and other materials and fabrics in a room. That will take some of the odorant out of the gas, reducing its odor intensity.

LP-Gas may stratify in a closed area, and the odor intensity could vary at different levels. Since it is heavier than air, there may be more odor at lower levels. Always be sensitive to the slightest gas odor. If you detect any odor, treat it as a serious leak. Immediately go into action as instructed earlier.

### SOME POINTS TO REMEMBER

- **Learn to recognize the odor of LP-gas.** Your local LP-Gas Dealer can give you a "Scratch and Sniff" pamphlet. Use it to find out what the propane odor smells like. If you suspect that your LP-Gas has a weak or abnormal odor, call your LP-Gas Dealer.
- If you are not qualified, do not light pilot lights, perform service, or make adjustments to appliances on the LP-Gas system. If you are qualified, consciously think about the odor of LP-Gas prior to and while lighting pilot lights or performing service or making adjustments.
- Sometimes a basement or a closed-up house has a musty smell that can cover up the LP-Gas odor. Do not try to light pilot lights, perform service, or make adjustments in an area where the conditions are such that you may not detect the odor if there has been a leak of LP-Gas.
- Odor fade, due to oxidation by rust or adsorption on walls of new cylinders and tanks, is possible. Therefore, people should be particularly alert and careful when new tanks or cylinders are placed in service. Odor fade can occur in new tanks, or reinstalled old tanks, if they are filled and allowed to set too long before refilling. Cylinders and tanks which have been out of service for a time may develop internal rust which will cause odor fade. If such conditions are suspected to exist, a periodic sniff test of the gas is advisable. **If you have any question about the gas odor, call your LP-gas dealer. A periodic sniff test of the LP-gas is a good safety measure under any condition.**
- If, at any time, you do not smell the LP-Gas odorant and you think you should, assume you have a leak. Then take the same immediate action recommended above for the occasion when you do detect the odorized LP-Gas.
- If you experience a complete "gas out," (the container is under no vapor pressure), turn the tank valve off immediately. If the container valve is left on, the container may draw in some air through openings such as pilot light orifices. If this occurs, some new internal rusting could occur. If the valve is left open, then treat the container as a new tank. Always be sure your container is under vapor pressure by turning it off at the container before it goes completely empty or having it refilled before it is completely empty.

## Qualified Installing Agency

Installation and replacement of gas piping, gas utilization equipment or accessories and repair and servicing of equipment shall be performed only by a qualified agency. The term "qualified agency" means any individual, firm, corporation, or company which whether in person or through a representative is engaged in and is responsible for (a) the installation or replacement of gas piping or (b) the connection, installation, repair or servicing of equipment, who is experienced in such work, familiar with all precautions required and has complied with all the requirements of the authority having jurisdiction.

The installation must conform with local codes, or in the absence of local codes, with the *National Fuel Gas Code, ANSI Z223.1\*/Canadian Installation Code, CAN/CGA B149*.

*\*Available from the American National Standards Institute, Inc., 11 West 42nd St., New York, N.Y. 10036.*

## Locating and Venting the Room Heater

Clearances: When facing the front of the room heater the minimum clearances to combustible construction (material) are the following:

Left side 6 inches (152mm). Right side 6 inches (152mm).

Recommended 18 inches (457mm) on left side for servicing.

Do not install in alcove or closet. No horizontal projection above heater permitted within 55 inches (140cm).

Ceiling 55 inches (140cm). Draft hood to rear wall 2 inches (51mm).

Open in front to provide service, access, and clearance to construction.

## Venting

1. Flue pipe must be as large as the flue collar on the draft diverter.
2. Maintain an upward slope of at least 1/4 inch (6mm) per foot of horizontal run.
3. Run flue pipe as directly as possible with a minimum of elbows.
4. Flue pipe should extend through the wall of a chimney to be flush with inner wall.
5. Flue pipe must be adequately supported by metal strips.
6. Single wall vent pipe may be attached directly to the draft hood of the room heater when a clearance of 2 1/2 inches (64mm) is maintained between the single wall vent pipe and the combustible wall of the room in which the room heater is located. Use double wall vent pipe for 1 inch (25mm) clearance to combustibles.
7. For flue pipe running through walls and roof, use B-1 [1 inch (25mm) clearance to combustibles] vent pipe.
8. Chimneys should extend at least 2 feet (.6m) above the roof and above any object or nearby building within 10 feet (3m).
9. Open tees should not be used in the flue pipe.
10. Appliance must not be connected to a chimney flue that is servicing a separate solid-fuel burning appliance.

For proper venting, do not attach a 90° elbow directly to draft diverter. If possible, attach 2 feet (.6m) of straight vent pipe before an elbow is used. Use of 45° elbows is recommended.

**Uninsulated single-wall metal pipe shall not be used outdoors in cold climates for venting gas utilization equipment.**

## Ventilation and Combustion Air

Room heaters shall be installed in a location in which the facilities for ventilation permit satisfactory combustion of gas and proper venting under normal conditions. In buildings of conventional frame, brick or stone construction without tight storm windows and doors, infiltration is normally adequate to provide for combustion and draft hood dilution.

Where appliances are installed in a confined space within a building, the building being of unusually tight construction, air for combustion and ventilation must be obtained directly from outdoors or from such spaces that freely communicate with the outdoors. Under these conditions, the confined space shall be provided with two permanent openings, one near the top of the enclosure and one near the bottom;

each opening shall have a free area of not less than one square inch (6.5cm<sup>2</sup>) per 1,000 BTU's (.3KW) of total input. The draft hood must be in the same atmospheric pressure zone as the combustion air inlet to the appliance.

## Gas Supply

Check all local codes for requirements, especially for the size and type of gas supply line required. On Natural gas lines less than 15' (4.5m) long, use 1/2" (13mm) pipe; on longer runs, use 3/4" (19mm) iron pipe or equal. On LP gas lines please consult LP gas supplier.

## Installing a New Main Gas Cock

Each appliance should have its own manual gas cock.

A manual main gas cock should be located in the vicinity of the unit. Where none exists, or where its size or location is not adequate, contact your local authorized installer for installation or relocation.

Compounds used on threaded joints of gas piping shall be resistant to the action of liquefied petroleum gases. The gas lines must be checked for leaks by the installer. This should be done with a soap solution, watching for bubbles on all exposed connections and, if unexposed, a pressure test should be made.

## Never Use an Exposed Flame to Check for Leaks.

**Appliance must be disconnected from piping at inlet of control valve and pipe capped or plugged for pressure test. Never Pressure Test With Appliance Connected; Control Valve Will Sustain Damage!**

A gas valve and ground joint union should be installed in the gas line upstream of the gas control to aid in servicing. It is required by the National Fuel Gas Code that a drip line be installed near the gas inlet. This should consist of a vertical length of pipe, tee connected into the gas line, that is capped on the bottom in which condensation and foreign particles may collect.

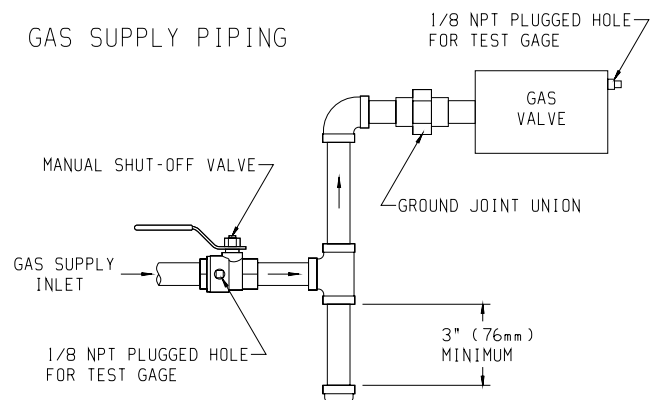

## Method of Installing A Tee Fitting Sediment Trap

The use of the following gas connectors is recommended:

- ANS Z21.24 Appliance Connectors of Corrugated Metal Tubing and Fittings
- ANS Z21.45 Assembled Flexible Appliance Connectors of Other Than All-Metal Construction

The above connectors may be used if acceptable by the authority having jurisdiction.

## Pressure Testing of the Gas Supply System

1. To check the inlet pressure to the gas valve, a 1/8" (3mm) N.P.T. plugged tapping, accessible for the test gauge connection, must be placed immediately upstream of the gas supply connection to the appliance.
2. The appliance, and its individual shutoff valve, must be disconnected from the gas supply piping system during any pressure testing of that system at test pressures in excess of 1/2 psig (3.5kPa).

- The appliance must be isolated from the gas supply piping system by closing its individual manual shutoff valve during any pressure testing of the gas supply piping system at test pressures equal to or less than 1/2 psig (3.5kPa).

**Attention!** If one of the above procedures results in pressures in excess of 1/2 psig (14" w.c.) (3.5kPa) on the appliance gas valve, it will result in a hazardous condition.

### Checking Manifold Pressure

Both Propane and Natural gas valves have a built-in pressure regulator that has a sealed adjustment. Natural gas models will have a manifold pressure approximately 4.0" w.c. (.996kPa) at the valve outlet with the inlet pressure to the valve from a minimum of 5.0" w.c. (1.245kPa) for the purpose of input adjustment to a maximum of 10.5" w.c. (2.61kPa) Propane gas models will have a manifold pressure approximately 10.0" w.c. (2.49kPa) at the valve outlet with the inlet pressure to the valve from a minimum of 11.0" w.c. (2.739kPa) for the purpose of input adjustment to a maximum of 13.0" w.c. (3.237kPa).

A 1/8" (3mm) N.P.T. plugged tapping, accessible for test gauge connection is located on the outlet side of the gas control.

### Liner and Insulated Liner

When you install a vented room heater into a masonry chimney you must follow these steps.

- The chimney must be lined and sized properly. Most masonry chimneys are over sized and absorb too much heat to be considered a proper vent. If you have any doubts line the chimney with the right size liner. If it's unlined you must line it.
- Use an insulated liner when the chimney is on the outside, three sides exposed to the weather, and there is no clay liner in the chimney. The insulation will help keep the flue gases warmer.

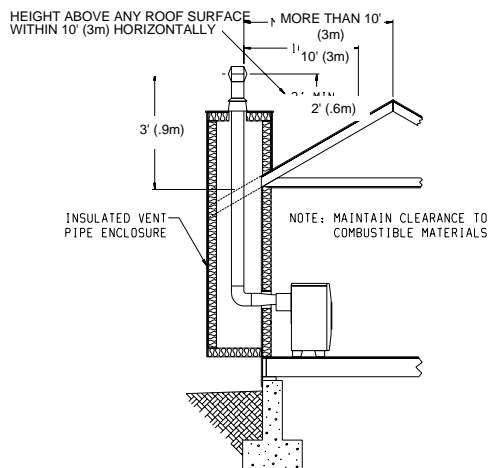

### Insulated Vent Enclosure

Vented room heaters installed with the vent going directly to the outside and above the eaves can cause poor venting. The cold pipe will have a delay in proper venting and cause the room heater to shut "off" by the vent safety switch. To prevent delayed venting as well as condensation of flue products an insulated enclosure is recommended.

Use type B 5" (127mm) diameter vent pipe and maintain at least a one inch (25mm) clearance to combustibles.

Use metal thimble to protect vent pipe as it passes through combustibles.

### High Altitudes

For altitudes/elevations above 2,000 feet (610m), input ratings should be reduced at the rate of 4 percent for each 1,000 feet (305m) above sea level. **Canadian High Altitudes** for locations having an elevation above mean sea level between 2,000 feet (610m) and 4,500 feet (1370m), the manifold pressure is to be decreased from 4.0" w.c. (.996kPa) to 3.2" w.c. (.797kPa) for Natural Gas and from 10.0" w.c. (2.49kPa) to 8.0" w.c. (1.99kPa) for Propane Gas.

### Piezo Pilot Ignitor Instructions

Depressing the red button completely causes a spark to occur at the pilot.

To light the pilot, it is important that the electrode be 1/8" (3mm) from the thermocouple. The spark must occur at the point the burner flame hits the thermocouple. The end of the electrode will be red hot with the pilot "On".

On a new installation with air in the gas line, it is suggested that a match be used. The match will light the pilot faster than the piezo under this condition.

### Vent Safety Shutoff System

This heater must be properly connected to a venting system. This heater is equipped with a vent safety shutoff system.

**Warning:**  
**Operation of this heater, when not connected to a properly installed and maintained venting system or tampering with the vent safety shutoff system, can result in carbon monoxide (CO) poisoning and possible death.**

This appliance needs fresh air for safe operation and must be installed so there are provisions for adequate combustion and ventilation air.

This room heater is equipped with a vent safety switch. The vent safety switch will cause gas flow to the pilot to "shut off" due to improper venting or a blocked flue.

If the vent safety switch continues to "shut off" the gas flow to the pilot a qualified service person must be contacted to inspect for improper venting, blockage in the vent pipe or the vent safety switch for being defective.

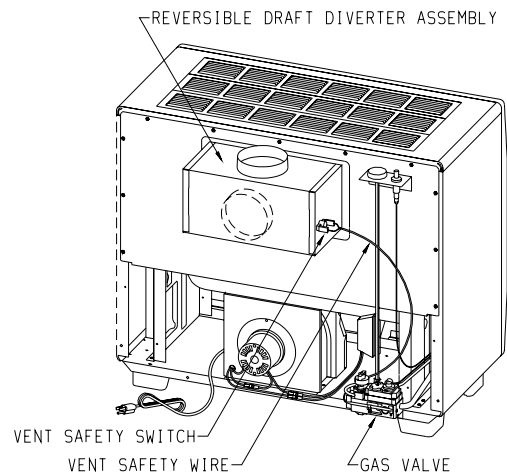

DRAFT DIVERTER CAN BE EITHER A VERTICAL VENT OR HORIZONTAL VENT

### Reversible Vertical or Horizontal Draft Diverter

This room heater has a reversible draft diverter. The draft diverter is installed in the vertical position at the factory. Please use the following steps to change the draft diverter from the vertical position to the horizontal position.

- Remove L280 vent safety switch from the draft diverter.
- Inside your yellow instruction envelope will be a 1 1/2" x 2 1/4" (38mm x 51mm) vent safety switch hole cover plate and two (2) 1/2" screws for attachment of vent safety switch hole cover plate to the draft diverter. Attach vent safety switch hole cover plate over hole on the draft diverter from which the L280 vent safety switch was removed.
- Remove two (2) screws at bottom of draft diverter and lift upward to remove draft diverter from the draft diverter plate. Rotate draft diverter into the horizontal position and slide back into the draft diverter plate. Attach two (2) screws into bottom of the draft diverter.
- Remove vent safety switch hole knockout and two (2) knockouts for screws on opposite side of draft diverter.
- Attach L280 vent safety switch to the draft diverter.
- Repositioning of the draft diverter is completed.

### Proper Pilot Flame

The correct flame will be almost horizontal, blue and will extend past the thermocouple 1/4" (6mm). The flame will surround the thermocouple just below the tip.

On Propane (LP-gas) slight yellow might occur where the pilot flame and the burner flame meet.

Natural gas pilots require adjusting when the inlet pressure is above 5" w.c. (1.25kPa). Remove pilot adjustment cover. Turn adjustment screw clockwise to reduce flame.

Propane (LP-gas) will not require adjusting.

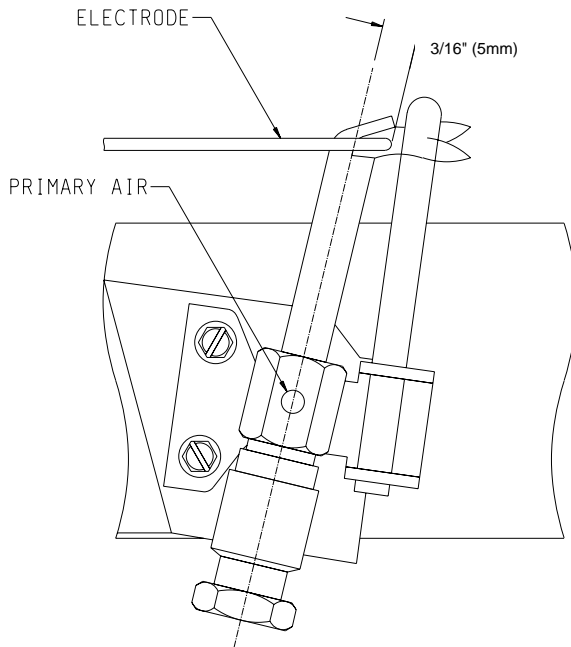

### Proper Main Burner Flame

There will be a short blue inner flame with a larger, lighter blue secondary flame. The burner flame may have yellow tips when hot. Dust in the combustion air will produce an orange or red flame. Do not mistake the orange or red flame for an improper yellow flame. The flame will be proper if the factory-set pressure and orifice are used. After use, cleaning may be required for the proper flame.

### Cleaning Pilot Burner

After use, cleaning of the pilot burner may be required for the proper flame. The pilot orifice can be cleaned with high pressure air or by placing under running water. Pilot orifice must be dry before replacement. Use a pipe cleaner to clean inside the pilot after the pilot orifice has been removed.

### Removing Pilot Orifice

1. Disconnect the pilot supply line at the pilot burner.
2. Remove pilot orifice from pilot burner. It may be necessary to tap on pilot burner in order to remove the pilot orifice.

### Cleaning Main Burner

Remove the burner and apply water pressure inside the throat of the burner and down into the ports; follow with air pressure.

### Removing Main Burner

1. Remove casing front.
2. Disconnect pilot bracket from the burner.
3. Remove brass nut from burner.
4. Disconnect burner from chamber leg flange.
5. Remove burner from bottom of combustion chamber.

### Cleaning Combustion Chamber

A qualified serviceman should remove the chamber and apply air pressure to the inside in order to clear all passageways.

### Thermostat Operation

To turn on burner, rotate dial knob toward setting number 9. To shut down burner, rotate dial knob toward setting number 1.

The dial numbers 1 to 9 correspond to 58° to 90°F (14° to 32°C). This is the temperature at the bulb thermostat not the room temperature. The owner is advised to determine the particular heat setting that is desired for comfort, as heating requirements are different for every owner.

**Attention:** When the dial knob is turned below number 1, to the white indicator mark and the bulb temperature drops to 55°F (13°C), the thermostat will call for heat and the main burner will ignite.

If no heat is desired, turn the gas control knob to the PILOT position.

### Primary Air Adjustment

1. A primary air adjustment bolt is located on left, front of burner throat. The bolt can be screwed into burner throat to REDUCE primary air or unscrewed from burner throat to INCREASE primary air.

To reduce yellow flame on main burner unscrew bolt from burner throat. Also, refer to Step 2.

To reduce resonance (whistling) noise or extinction (popping) noise screw bolt into burner throat.

2. An air shutter bracket is attached to top of burner throat. The air shutter bracket lays flat across top of burner throat.

If yellow flames can not be removed from main burner by using primary air adjustment bolt, the air shutter bracket can be pivoted upward to allow additional primary air to enter burner throat.

**On Propane gas, if a whistling noise (resonation) occurs screw the air adjustment bolt into the burner throat to eliminate the whistling noise (resonation).**

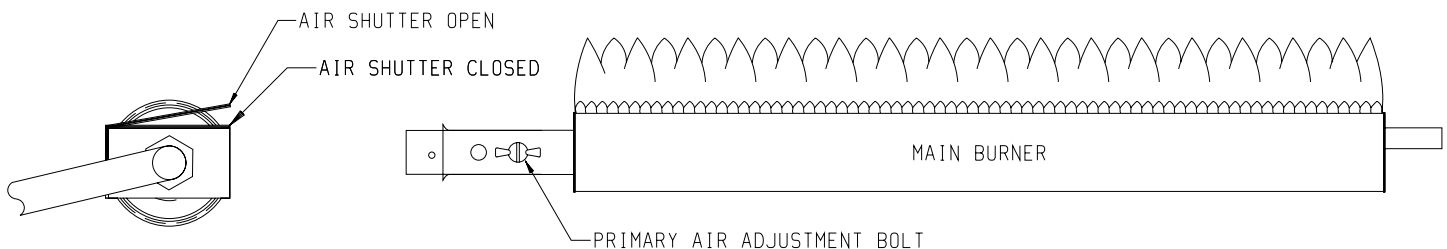

## FOR YOUR SAFETY READ BEFORE LIGHTING

**WARNING: If you do not follow these instructions exactly, a fire or explosion may result causing property damage, personal injury, or loss of life.**

- A. This appliance has a pilot which must be lighted by hand. When lighting the pilot, follow these instructions exactly.
- B. **BEFORE LIGHTING** smell all around the appliance area for gas. Be sure to smell next to the floor because some gas is heavier than air and will settle on the floor.

### WHAT TO DO IF YOU SMELL GAS

- Do not try to light any appliance.
- Do not touch any electrical switch; do not use any phone in your building.
- Immediately call your gas supplier from a neighbor's phone. Follow the gas supplier's instructions.

- If you cannot reach your gas supplier, call the fire department.

- C. Use only your hand to push in or turn the gas control knob. Never use tools. If the knob will not push in or turn by hand, don't try to repair it; call a qualified service technician. Force or attempted repair may result in a fire or explosion.
- D. Do not use this appliance if any part has been under water. Immediately call a qualified service technician to inspect the appliance and to replace any part of the control system and any gas control which has been under water.

## LIGHTING INSTRUCTIONS

1. **STOP!** Read the safety information above.
2. Set thermostat to lowest setting.
3. Turn off all electric power to the appliance (if applicable).
4. Push in gas control knob slightly and turn clockwise  to "OFF".

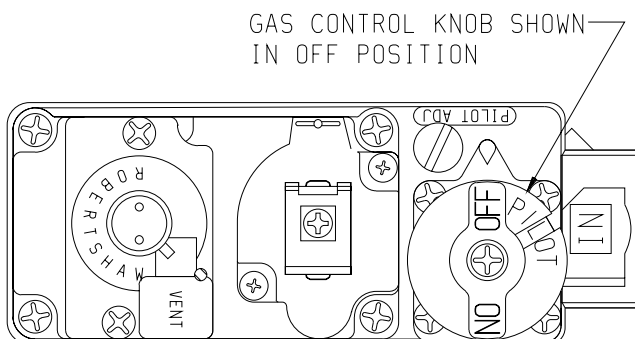



**NOTE:** Knob cannot be turned from "PILOT" to "OFF" unless knob is pushed in slightly. Do not force.

5. Wait ten (10) minutes to clear out any gas. Then smell for gas, including near the floor. If you smell gas, **STOP!** Follow "B" in the safety information above. If you don't smell gas, go to the next step.
6. Remove casing front and find pilot by following

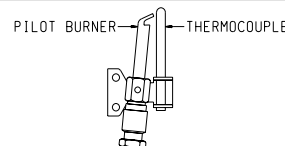
metal tube from gas control. Observe pilot through combustion chamber glass.



7. Turn knob on gas control counterclockwise  to "PILOT."
8. Push and hold gas control knob in and repeatedly push the ignitor button until pilot is lit (or use match to light). Continue to hold gas control knob in for about one (1) minute after the pilot is lit. Release knob and it will pop back up. Pilot should remain lit. If it goes out, repeat steps 4 through 8.
  - If knob does not pop up when released, stop and immediately call your qualified service technician or gas supplier.
  - If the pilot will not stay lit after several tries, turn the gas control knob to "OFF" and call your service technician or gas supplier.
9. Replace casing front.
10. Turn gas control knob counterclockwise  to "ON."
11. Turn on all electric power to the appliance (if applicable).
12. Set thermostat to desired setting.

## TO TURN OFF GAS TO APPLIANCE

1. Set thermostat to lowest setting.
2. Turn off all electric power to appliance (if applicable) if service is to be performed.
3. Push in gas control knob slightly and turn clockwise  to "OFF". Do not force.

# SERVICE AND MAINTENANCE SUGGESTIONS

## SYMPTOMS-POSSIBLE CAUSES OR CORRECTION

1. **Impossible to light pilot**
  - a. If using piezo ignitor, check electrode location.
  - b. Remove nut at orifice and check for gas.
  - c. If gas available, check for blocked orifice or pilot.
2. **Pilot outage**
  - a. Proper size of pilot flame.
  - b. Defective or weak thermocouple.
3. **Pilot flames but goes out**
  - a. Pilot flame not covering the thermocouple properly when knob is released.
  - b. Defective thermocouple.
  - c. Defective magnet in the safety section of valve.
4. **Poor thermostatic control**
  - a. Thermostat needs calibrating.
  - b. Defective thermostat section.
5. **Noisy blower**
  - a. Tighten blower screws.
  - b. Check blower wheel in the open for balance.
6. **Yellow main burner flame**
  - a. Remove main burner to check for obstructions in throat, ports and orifices.
  - b. Install new main burner orifice and pilot orifice.
  - c. Check gas valve for leaking.
- d. Open the air bolt on the main burner in order to increase the amount of primary air.
7. **Yellow pilot flame**
  - a. Small yellow tip not objectionable.
  - b. Remove pilot orifice. Check and clean.
8. **Pilot and main burner goes out after burning a few minutes**
  - a. Improper venting of flue products. Relight and check for improper venting.
  - b. If vented properly, check vent safety switch, replace if defective
9. **Burner back-flashes or 'pops' and burns at main burner orifice**
  - a. Examine burner for defects
10. **Inoperative blower**
  - a. Check fan control by shorting across terminals.
  - b. Check for blower wheel bind by removing wheel and operating motor.
  - c. Check for frozen bearings due to lack of oil.
11. **On Propane gas, if a whistling noise (resonation) occurs**
  - a. Screw the air adjustment bolt into the burner throat to eliminate the whistling noise (resonation).
  - b. Size main burner orifice with a drill bit. For RH-50-5 use #47 drill bit. For RH-65-5 use #43 drill bit.

**PLEASE NOTE:** When ordering parts, it is very important that **part number** and **description** of part coincide.

| INDEX NO. | PART NUMBER | DESCRIPTION   | INDEX NO. | PART NUMBER | DESCRIPTION                                    |
|-----------|-------------|---|-----------|-------------|--|
| 1         | RH-833      | Diverter Assembly                                     | 26        | 742228      | Main Burner Orifice (RH-65-5 LPG)              |
| 2         | RH-802      | Down Draft Shield                                     | 26        | 742235      | Main Burner Orifice (RH-50-5 LPG)              |
| 3         | RH-800      | Draft Diverter Plate                                  | 27        | RH-856      | Valve Bracket                                  |
| 4         | RH-637      | Casing Top (RH-50-5)                                  | 28        | R-2702      | Gas Valve (Nat)                                |
| 4         | RH-613      | Casing Top (RH-65-5)                                  | 28        | R-2703      | Gas Valve (LPG)                                |
| 5         | RH-603      | Louver (RH-50-5, 3 Required)<br>(RH-65-5, 4 Required) | 29        | RH-623      | Control Rod                                    |
| 6         | RH-834      | Casing Back   | 30        | RH-832      | Control Rod Bracket                            |
| 7         | RH-652      | Combustion Chamber Assembly<br>(RH-50-5)              | 31        | R-2708      | Piezo Ignitor                                  |
| 7         | RH-626      | Combustion Chamber Assembly<br>(RH-65-5)              | 32        | 662015      | Control Knob                                   |
| 8         | RH-654      | Chamber Shield - Right (RH-50-5)                      | 33        | RH-036      | Motor Mounting Plate                           |
| 8         | RH-655      | Chamber Shield - Right (RH-65-5)                      | 34        | 632016      | Motor Cushion                                  |
| 9         | RH-640      | Casing Side (RH-50-5)                                 | 35        | R-2605      | Motor  |
| 9         | RH-602      | Casing Side (RH-65-5)                                 | 36        | RH-602      | Casing Side (RH-65-5)                          |
| 10        | 862029      | Radiant Glass with Rope Gasket                        | 36        | RH-640      | Casing Side (RH-50-5)                          |
| 10        | RH-857      | Rope Gasket   | 37        | RH-653      | Chamber Shield - Left                          |
| 11        | 642031      | Blower Wheel  | 38        | R-2099      | Cord Set                                       |
| 12        | RH-667      | Blower Housing and Chute Assembly                     | 39        | RH-656      | Chamber Shield - Rear                          |
| 13        | RH-454      | Frame for Glass                                       | 40        | R-2091      | Wire Assembly                                  |
| 14        | RH-138      | Blower Cushion  | 41        | 8720161     | Strain Relief Bushing                          |
| 15        | RH-618      | Inner Front   | 42        | 872087      | Bushing  |
| 16        | RH-641      | Casing Bottom Assembly (RH-50-5)                      | 43        | 9120106     | Fan Control Switch                             |
| 16        | RH-616      | Casing Bottom Assembly (RH-65-5)                      | 44        | DV-806      | Switch Box                                     |
| 17        | RH-853      | Burner Assembly                                       | 45        | DV-807      | Switch Box Cover                               |
| 18        | RH-619      | Casing Front with Heat Shield                         | 46        | 871018      | Cable Assembly                                 |
| 19        | R-776-B     | Thermocouple  | 47        | R-2706      | Eco Switch                                     |
| 20        | RH-620      | Pouch   | Not Shown | 652121      | Regulator (Nat)                                |
| 21        | 762223      | Pilot Burner with Orifice (LPG)                       | Not Shown | 652211      | Regulator (LPG)                                |
| 21        | 762126      | Pilot Burner with Orifice (Nat)                       | Not Shown | R-2738      | Operator/Regulator (Nat)                       |
| 22        | 732064      | Electrode and Wire Assembly                           | Not Shown | R-2739      | Operator/Regulator (LPG)                       |
| 23        | RH-829      | Pilot Tubing (RH-50-5)                                | Not Shown | 742148      | Pilot Orifice .011 (Nat)                       |
| 23        | RH-830      | Pilot Tubing (RH-65-5)                                | Not Shown | 742250      | Pilot Orifice .008 (LPG)                       |
| 24        | RH-457      | Air Shutter Bracket (LPG Only)                        | Not Shown | RH-527      | Glass and Frame Assembly<br>(includes 10 & 13) |
| 25        | P-206       | Manifold Assembly (RH-50-5)                           | Not Shown | R-2707      | Junction Block Adaptor/ECO Switch              |
| 25        | P-207       | Manifold Assembly (RH-65-5)                           | Not Shown | UH-441      | Vent Safety Switch/ECO Hole Cover<br>Plate     |
| 26        | P86-27N     | Main Burner Orifice (RH-65-5 Nat)                     |           |             |  |
| 26        | 742124      | Main Burner Orifice (RH-50-5 Nat)                     |           |             |  |

**USE ONLY MANUFACTURER'S REPLACEMENT PARTS. USE OF ANY OTHER PARTS COULD CAUSE INJURY OR DEATH.**



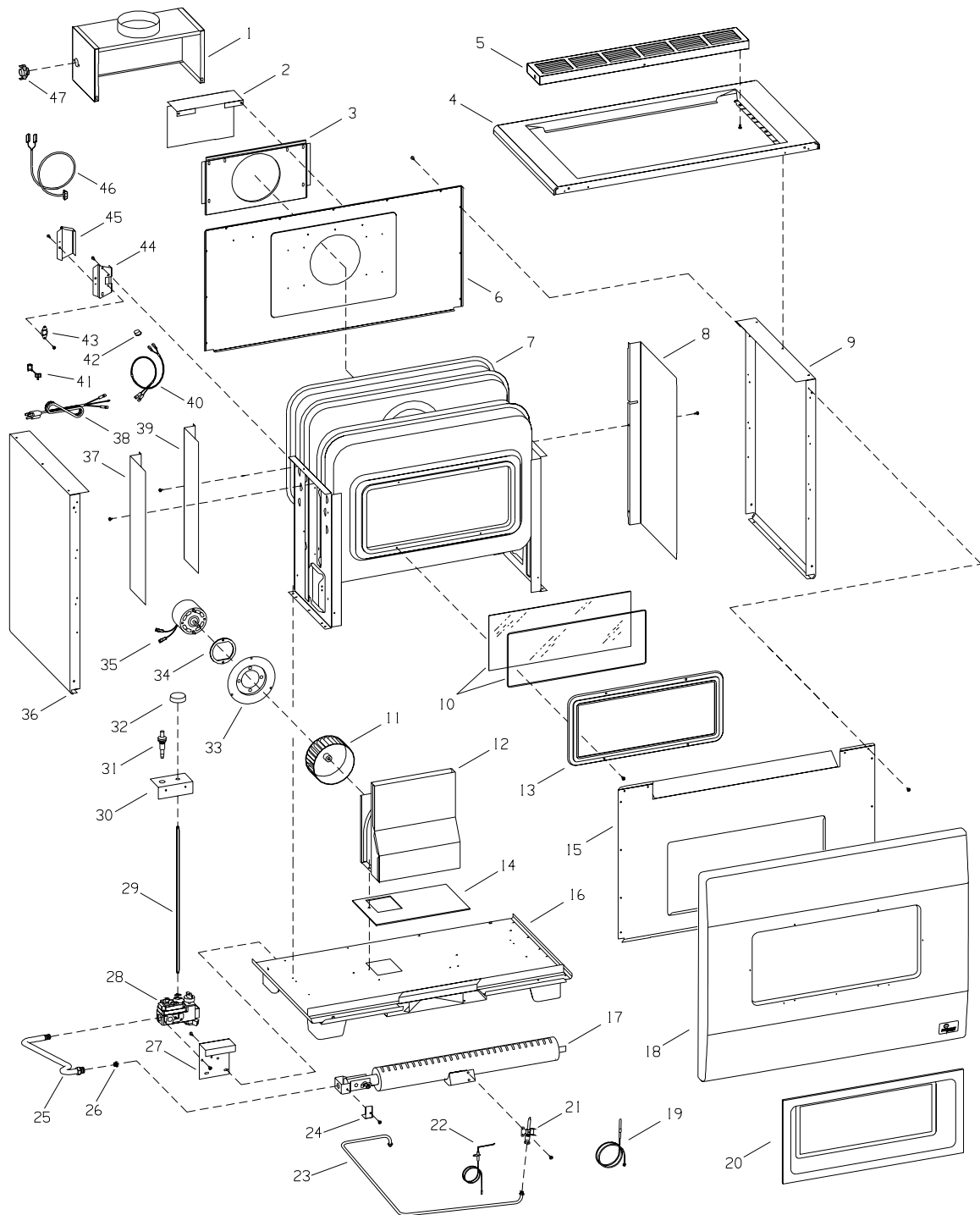

**PLEASE NOTE:** When ordering parts, it is very important the part number and description of part coincide.

**How To Order Repair Parts . . .**

Parts can be ordered **only** through your **service person or dealer**. For best results, the **service person or dealer** should order parts through the distributor. Parts can be shipped directly to the **service person/dealer**.

All parts listed in the Parts List have a Part Number. When ordering parts, first obtain the Model Number from the name plate on your equipment. Then determine the Part Number (**not** the Index Number) and the Description of each part from the following appropriate illustration and list. Be sure to give all this information . . .

Furnace Model Number \_\_\_\_\_ Part Description \_\_\_\_\_  
 Furnace Serial Number \_\_\_\_\_ Kind of Gas (Propane or Natural) \_\_\_\_\_  
 Part Number \_\_\_\_\_

Do not order bolts, screws, washers or nuts. They are standard hardware items and can be purchased at any local hardware store.

Shipments contingent upon strikes, fires and all causes beyond our control.

## OPTIONAL BLOWER

### FRB-3 For Vented Visual Flame Room Heaters Models RH-50-(1, 2, 4, 5) and RH-65-((1, 2, 4, 5)

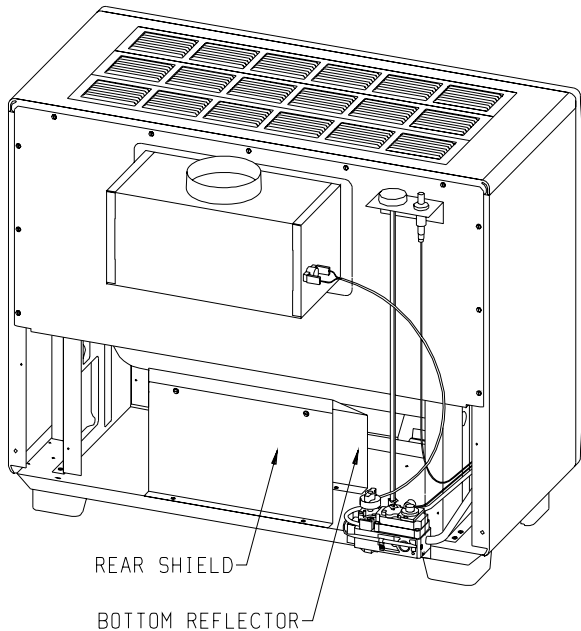

**Figure 1**

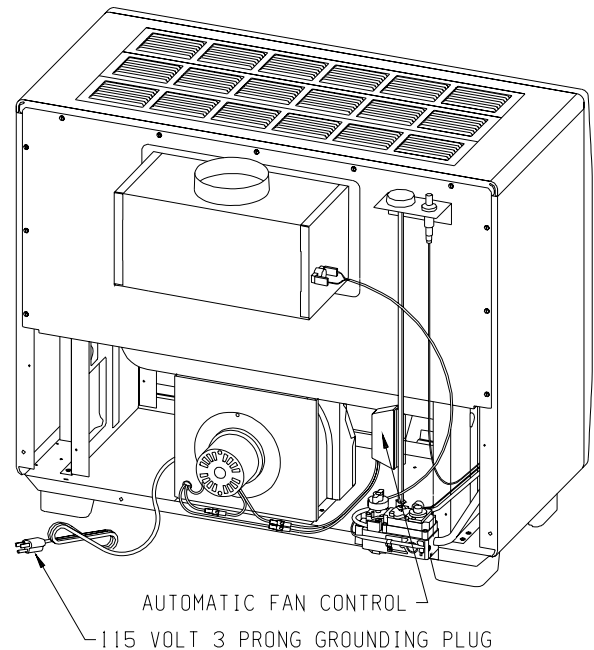

**Figure 2**

#### Installing Optional Blower

1. Remove rear shield (2 screws) and bottom reflector (4 screws). (See Figure 1)
2. Align blower cushion with bottom assembly air discharge opening. Foil face side of blower cushion should be placed upward.
3. Align blower housing with blower cushion and use two, #10 x 1/2" (13mm) hex-head screws to attach blower housing to bottom assembly. (See Figure 2)
4. Save bottom reflector and rear shield (removed in Step 1) in the event the blower housing is removed from room heater. **Attention! Bottom reflector and rear shield must be attached to bottom assembly whenever the blower housing is removed from the room heater and the room heater is in operation.**
5. Remove switch box cover from the switch box by removing the #8 x 1/4" (6mm) hex-head screw.
6. There are two screw holes on the lower back of the combustion chamber. Use only the left screw hole for mounting.
7. With the switch box perpendicular to the combustion chamber, align the round clearance hole on the switch box with the left screw hole on the combustion chamber. (See Figure 3)
8. Attach switch box to the combustion chamber using the #10 x 1/2" (13mm) hex-head screw provided.
9. Attach switch box cover to the switch box by using the #8 x 1/4" (6mm) hex-head screw. (See Figure 4)

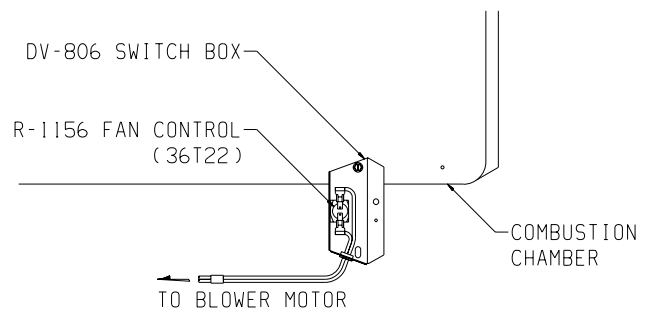

**Figure 3**

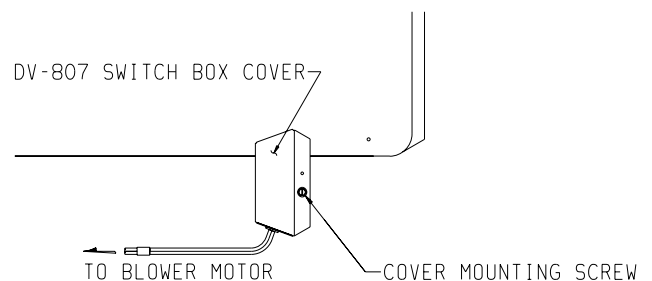

**Figure 4**

**Attention:** Wiring harness on blower is factory assembled and installed. If wiring harness becomes disassembled use the following steps to reassemble the wiring harness.

1. Attach (1) pin terminal from black (hot) wire, smooth insulation on cord set to (1) socket terminal on fan control assembly.
2. Attach (1) pin terminal from black (neutral) wire, ribbed insulation on cord set to (1) socket terminal from white (neutral) wire on motor.
3. Attach (1) pin terminal on fan control assembly to (1) socket terminal from black (hot) wire on motor.
4. Attach green ground wire beneath one of the #10 x 1/2" (13mm) screws on the blower housing.

**Fan Control**

The automatic fan control is located in the switch box. The switch box is attached to the front of the blower assembly. The switch box is adjacent to the combustion chamber. The fan control is a non-adjustable automatic type. The fan control will require between 5 and 10 minutes of main burner operation before the fan control "closes" and activates the blower. The blower will continue to run between 5 and 10 minutes after the main burner shuts off, before the fan control "opens" and deactivates the blower.

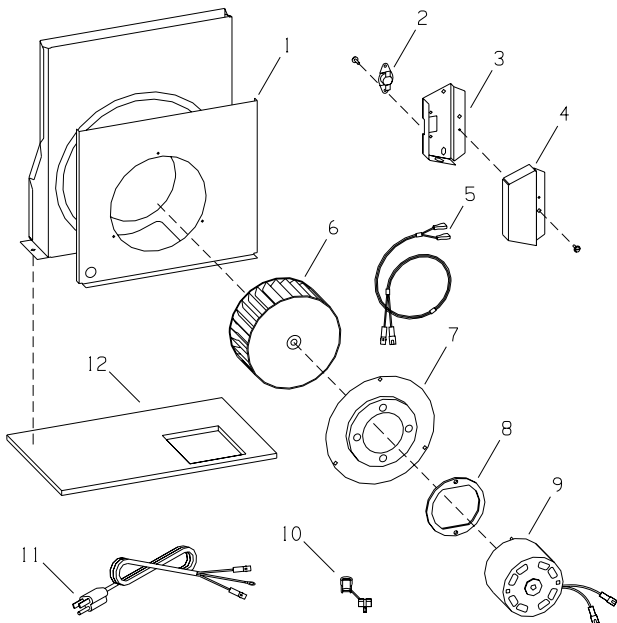

| Index No. | Part No. | Description                       |
|-----------|----------|-----------------------------------|
| 1         | RH-667   | Blower Housing and Chute Assembly |
| 2         | 9120106  | Fan Control Switch                |
| 3         | DV-806   | Switch Box                        |
| 4         | DV-807   | Switch Box Cover                  |
| 5         | R-2091   | Wire Assembly                     |
| 6         | 642031   | Blower Wheel                      |
| 7         | RH-036   | Motor Mounting Plate              |
| 8         | 632016   | Motor Cushion                     |
| 9         | R-2605   | Motor                             |
| 10        | 8720161  | Strain Relief Bushing             |
| 11        | R-2099   | Cord Set                          |
| 12        | RH-138   | Blower Cushion                    |

**Wiring**

The appliance, when installed, must be electrically grounded in accordance with local codes or, in the absence of local codes, with the *National Electrical Code, ANSI/NFPA 70* or *Canadian Electrical Code, CSA C22.1*, if an external electrical source is utilized. **This appliance is equipped with a three-prong [grounding] plug for your protection against shock hazard and should be plugged directly into a properly grounded three-prong receptacle. Do not cut or remove the grounding prong from this plug.** For an ungrounded receptacle, an adapter, which has two prongs and a wire for grounding, can be purchased, plugged into the ungrounded receptacle and its wire connected to the receptacle mounting screws. With this wire completing the ground, the appliance cord plug can be plugged into the adapter and be electrically grounded. A 7/8" (22mm) hole is provided in the junction box for use with a conduit connector if local codes require this type of protection.

**Wiring Diagram**

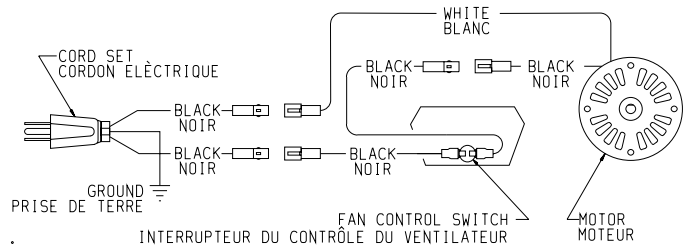

If any of the original wire as supplied with the appliance must be replaced, it must be replaced with type 125°C wire or its equivalent.

**CAUTION:** Label all wires prior to disconnection when servicing controls. Wiring errors can cause improper and dangerous operation. Verify proper operation after servicing.

**Warning:**  
**Unplugging of blower accessory will not stop the heater from cycling. To shut heater off:**  
 1. Turn temperature dial or thermostat to lowest setting.  
 2. Turn knob on gas control to "OFF", depressing slightly. Do not force.

**Cleaning**

The blower wheel will collect lint and could require cleaning once a year. If the air output decreases or the noise level increases, it indicates a dirty wheel. Complete removal of the wheel and scrubbing it with a brush under flowing water is recommended.

**Oiling**

The blower motor has an oil hole located on each end of the motor. Use #20 motor oil only. It is best to oil the motor several times during the heating season using 2 or 3 drops each time. If the motor fails to start and hums, it could be a tight bearing due to lack of oil. This may be corrected by pouring kerosene in the oil holes, allowing to stand for a few hours and then oiling properly.