

This Owner's Manual is provided and hosted by [Appliance Factory Parts](http://www.appliancefactoryparts.com).

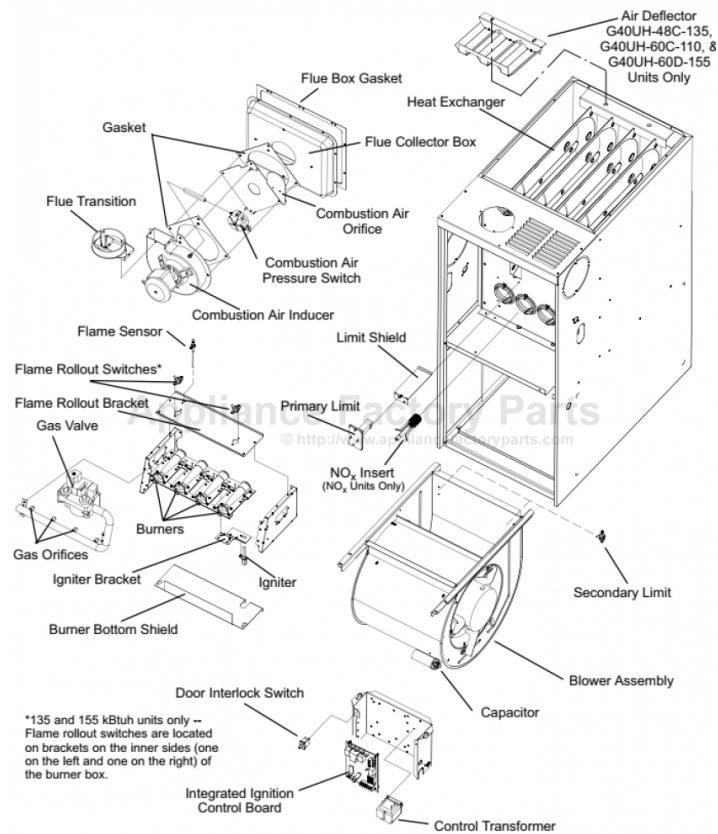

LENNOX G40UH-36B-090-05 Owner's Manual

**Shop genuine replacement parts for LENNOX
G40UH-36B-090-05**



Find Your LENNOX HVAC Parts - Select From 25 Models

----- Manual continues below -----



©2006 Lennox Industries Inc.
Dallas, Texas, USA

INSTALLATION INSTRUCTIONS

G40UH(X) Series



GAS FURNACE
505,181M
03/2006
Supersedes 505,011M

TP Technical
Publications

Litho U.S.A.

Table of Contents

Unit Dimensions	2
G40UH(X) Parts Arrangement	3
G40UH(X) Gas Furnace	4
Shipping and Packing List	4
Safety Information	4
General	5
Combustion, Dilution & Ventilation Air	5
Setting Equipment	8
Filters	12
Duct System	12
Venting	12
Gas Piping	20
Electrical	21
Unit Start-Up	25
Gas Pressure Adjustment	26
High Altitude Information	27
Other Unit Adjustments	27
Service	28
Repair Parts List	30
Ignition Control Board Diagnostic Codes	31
Troubleshooting	32
Start-Up & Performance Check List	35

**RETAIN THESE INSTRUCTIONS
FOR FUTURE REFERENCE**



! WARNING

FIRE OR EXPLOSION HAZARD.



Failure to follow safety warnings exactly could result in serious injury, death, or property damage.



Do not store or use gasoline or other flammable vapors and liquids in the vicinity of this or any other appliance.

Installation and service must be performed by a qualified installer, service agency or the gas supplier.

WHAT TO DO IF YOU SMELL GAS:

- **Do not try to light any appliance.**
- **Do not touch any electrical switch; do not use any phone in your building.**
- **Leave the building immediately.**
- **Immediately call your gas supplier from a neighbor's phone. Follow the gas supplier's instructions.**
- **If you cannot reach your gas supplier, call the fire department.**



G40UH(X) Unit Dimensions - inches (mm)

***NOTE - 60C and 60D units that require air volumes over 1800 cfm (850 L/s) must have one of the following:**

1. Return air from single side with transition which will accommodate 20 x 25 x 1 in. (508 x 635 x 25 mm) cleanable air filter. (Required to maintain proper air velocity.)
2. Return air from single side with optional RAB Return Air Base.
3. Return air from bottom.
4. Return air from both sides.
5. Return air from bottom and one side.

Refer to Engineering Handbook for additional information.

**Flue outlet may be horizontal but furnace must be vented vertically
 ① Optional external side return air filter kit cannot be used with the optional RAB Return Air Base.

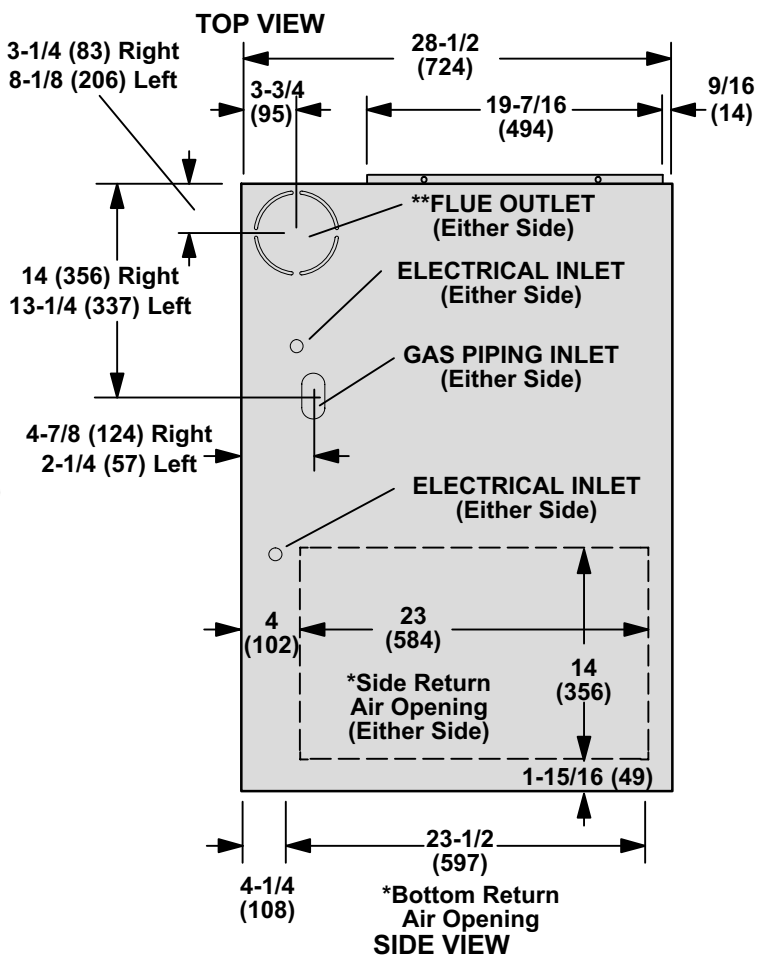
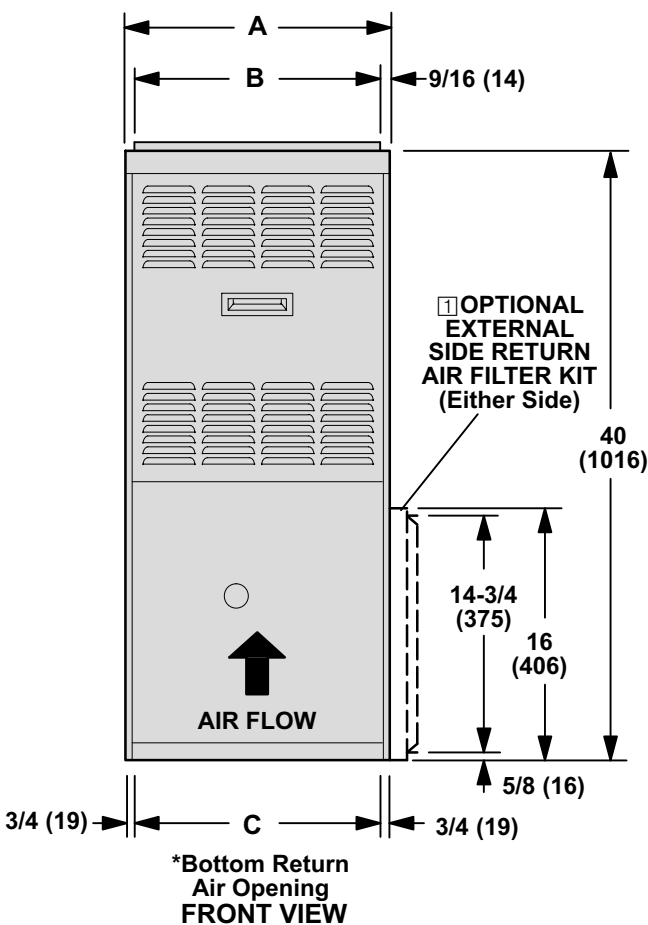
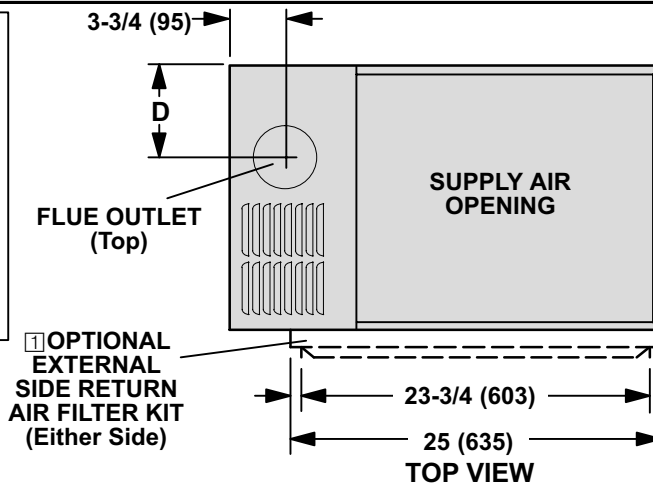

Model No.	A		B		C		D	
	in.	mm	in.	mm	in.	mm	in.	mm
G40UH-24A-045, G40UH-24A-070, G40UH-36A-045, G40UH-36A-070	14-1/2	368	13-3/8	340	13	330	4-1/2	114
G40UH-36B-090, G40UH-48B-070, G40UH-48B-090	17-1/2	446	16-3/8	416	16	406	6	152
G40UH-36B-110, G40UH-48C-110, G40UH-48C-135, G40UH-60C-110	21	533	19-7/8	454	19-1/2	495	7-3/4	197
G40UH-60D-135 G40UH-60D-155	24-1/2	622	23-3/8	546	23	584	9-1/2	241

G40UH(X) Parts Arrangement

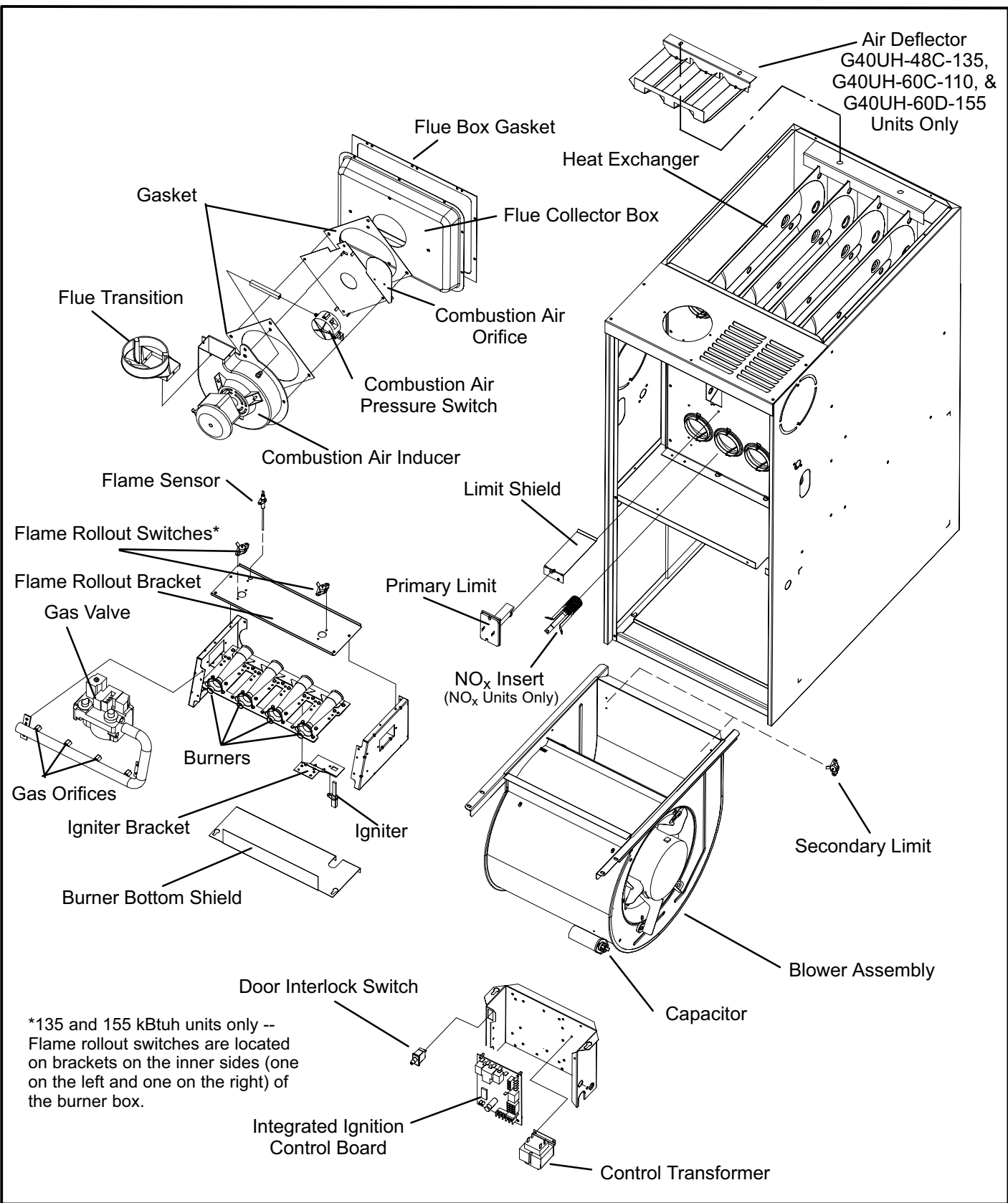

FIGURE 1

G40UH(X) Gas Furnace

The G40UH(X) gas furnace is shipped ready for installation in the upflow and horizontal position (left or right) fueled by natural gas. A conversion kit (ordered separately) is required for use in propane/LP gas applications. The furnace is shipped with the bottom panel in place. The bottom panel must be removed if the unit is to be installed in a horizontal application. The panel may also be removed in upflow applications.

Shipping and Packing List

Package 1 of 1 contains

- 1 - Assembled G40UH(X) unit
- 1 - Bag assembly containing the following:
 - 2 - Screws
 - 3 - Wire nuts
 - 1 - Snap bushing
 - 1 - Snap plug
 - 1 - Wire tie
 - 1 - Vent warning label
 - 1 - Owner's manual and warranty card

The following items may also be ordered separately:

- 1 - Thermostat
- 1 - Hanging bracket (for horizontal installations)
- 1 - Propane/LP changeover kit

Check equipment for shipping damage. If you find any damage, immediately contact the last carrier.

Safety Information

⚠ WARNING

Improper installation, adjustment, alteration, service or maintenance can cause property damage, personal injury or loss of life. Installation and service must be performed by a qualified installer, service agency or the gas supplier.

⚠ CAUTION

As with any mechanical equipment, personal injury can result from contact with sharp sheet metal edges. Be careful when you handle this equipment.

G40UH(X) units are CSA International certified to ANSI Z21.47 and CSA 2.3 standards.

In the USA, installation of gas furnaces must conform with local building codes. In the absence of local codes, units must be installed according to the current National Fuel Gas Code (ANSI-Z223.1). The National Fuel Gas Code is available from the following address:

American National Standards Institute, Inc.
11 West 42nd Street
New York, NY 10036

In Canada, installation must conform with current CSA B149 Natural Gas and Propane Installation Codes, local plumbing or waste water codes and other applicable local codes.

Adequate clearance must be made around the air openings into the vestibule area. In order to ensure proper unit operation, combustion and ventilation air supply must be provided according to the current National Fuel Gas Code or CSA B149 standards.

Vent installations must be consistent with the venting tables (in this instruction) and applicable provisions of local building codes.

This furnace is CSA International certified for installation clearances to combustible material as listed on the unit nameplate and in the tables in figures 6 and 11. Accessibility and service clearances must take precedence over fire protection clearances.

NOTE - For installation on combustible floors, the furnace shall not be installed directly on carpeting, tile, or other combustible material other than wood flooring.

For installation in a residential garage, the furnace must be installed so that the burner(s) and the ignition source are located no less than 18 inches (457 mm) above the floor. The furnace must be located or protected to avoid physical damage by vehicles. When a furnace is installed in a public garage, hangar, or other building that has a hazardous atmosphere, the furnace must be installed according to recommended good practice requirements and current National Fuel Gas Code or CSA B149 standards.

NOTE - Furnace must be adjusted to obtain a temperature rise within the range specified on the unit nameplate. Failure to do so may cause erratic limit operation and premature heat exchanger failure.

This G40UH(X) furnace must be installed so that its electrical components are protected from water.

When this furnace is used with cooling units, it shall be installed in parallel with, or on the upstream side of, cooling units to avoid condensation in the heating compartment. With a parallel flow arrangement, a damper (or other means to control the flow of air) must adequately prevent chilled air from entering the furnace. If the damper is manually operated, it must be equipped to prevent operation of either the heating or the cooling unit, unless it is in the full **HEAT** or **COOL** setting.

When installed, this furnace must be electrically grounded according to local codes. In addition, in the United States, installation must conform with the current National Electric Code, ANSI/NFPA No. 70. The National Electric Code (ANSI/NFPA No. 70) is available from the following address:

National Fire Protection Association
1 Battery March Park
Quincy, MA 02269

In Canada, all electrical wiring and grounding for the unit must be installed according to the current regulations of the Canadian Electrical Code Part I (CSA Standard C22.1) and/or local codes.

NOTE - This furnace is designed for a minimum continuous return air temperature of 60°F (16°C) or an intermittent operation down to 55°F (13°C) dry bulb for cases where a night setback thermostat is used. Return air temperature must not exceed 85°F (29°C) dry bulb.

NOTE - G40UH(X) series units should not be installed as a unit heater.

The G40UH(X) furnace may be installed in alcoves, closets, attics, basements, garages, and utility rooms in the up-flow or horizontal position.

This furnace design has not been CSA International certified for installation in mobile homes, recreational vehicles, or outdoors.

Lennox does not recommend the use of G40UH(X) units as a construction heater during any phase of construction. Very low return air temperatures, harmful vapors and operation of the unit with clogged or misplaced filters will damage the unit.

G40UH(X) units may be used for heating of buildings or structures under construction, if the following conditions are met:

- The vent system must be permanently installed per these installation instructions.
- A room thermostat must control the furnace. The use of fixed jumpers that will provide continuous heating is not allowed.
- The return air duct must be provided and sealed to the furnace.
- Return air temperature range between 60°F (16°C) and 80°F (27°C) must be maintained.
- Air filters must be installed in the system and must be maintained during construction.
- Air filters must be replaced upon construction completion.
- The input rate and temperature rise must be set per the furnace rating plate.
- One hundred percent (100%) outdoor air must be provided for combustion air requirements during construction. Temporary ducting may supply outdoor air to the furnace. Do not connect duct directly to the furnace. Size the temporary duct following these instructions in section for Combustion, Dilution and Ventilation Air in a confined space with air from outside.
- The furnace heat exchanger, components, duct system, air filters and evaporator coils must be thoroughly cleaned following final construction clean-up.
- All furnace operating conditions (including ignition, input rate, temperature rise and venting) must be verified according to these installation instructions.

NOTE - The Commonwealth of Massachusetts stipulates these additional requirements:

- Gas furnaces shall be installed by a licensed plumber or gas fitter only.
- The gas cock must be "T handle" type.
- When a furnace is installed in an attic, the passage-way to and service area surrounding the equipment shall be floored.

General

These instructions are intended as a general guide and do not supersede local codes in any way. Consult authorities having jurisdiction before installation.

In addition to the requirements outlined previously, the following general recommendations must be considered when installing a G40UH(X) furnace:

- Place the furnace as close to the center of the air distribution system as possible. The furnace should also be located close to the chimney or vent termination point.
- Do not install the furnace where drafts might blow directly into it. This could cause improper combustion and unsafe operation.
- Do not block the furnace combustion air openings with clothing, boxes, doors, etc. Air is needed for proper combustion and safe unit operation.
- When the furnace is installed in an attic or other insulated space, keep insulation away from the furnace.

⚠ WARNING

Product contains fiberglass wool.

Disturbing the insulation in this product during installation, maintenance, or repair will expose you to fiberglass wool. Breathing this may cause lung cancer. (Fiberglass wool is known to the State of California to cause cancer.)

Fiberglass wool may also cause respiratory, skin, and eye irritation.

To reduce exposure to this substance or for further information, consult material safety data sheets available from address shown below, or contact your supervisor.

**Lennox Industries Inc.
P.O. Box 799900
Dallas, TX 75379-9900**

Combustion, Dilution & Ventilation Air

In the past, there was no problem in bringing in sufficient outdoor air for combustion. Infiltration provided all the air that was needed. In today's homes, tight construction practices make it necessary to bring in air from outside for combustion. Take into account that exhaust fans, appliance vents, chimneys, and fireplaces force additional air that could be used for combustion out of the house. Unless outside air is brought into the house for combustion, negative pressure

(outside pressure is greater than inside pressure) will build to the point that a downdraft can occur in the furnace vent pipe or chimney. As a result, combustion gases enter the living space creating a potentially dangerous situation.

In the absence of local codes concerning air for combustion and ventilation, use the guidelines and procedures in this section to install G40UH(X) furnaces to ensure efficient and safe operation. You must consider combustion air needs and requirements for exhaust vents and gas piping. A portion of this information has been reprinted with permission from the National Fuel Gas Code (ANSI-Z223.1). This reprinted material is not the complete and official position of the ANSI on the referenced subject, which is represented only by the standard in its entirety.

In Canada, refer to the CSA B149 installation codes.

⚠ CAUTION

Do not install the furnace in a corrosive or contaminated atmosphere. Meet all combustion and ventilation air requirements, as well as all local codes.

⚠ CAUTION

Insufficient combustion air can cause headaches, nausea, dizziness or asphyxiation. It will also cause excess water in the heat exchanger resulting in rusting and premature heat exchanger failure. Excessive exposure to contaminated combustion air will result in safety and performance related problems. Avoid exposure to the following substances in the combustion air supply:

- Permanent wave solutions**
- Chlorinated waxes and cleaners**
- Chlorine base swimming pool chemicals**
- Water softening chemicals**
- De-icing salts or chemicals**
- Carbon tetrachloride**
- Halogen type refrigerants**
- Cleaning solvents (such as perchloroethylene)**
- Printing inks, paint removers, varnishes, etc.**
- Hydrochloric acid**
- Cements and glues**
- Antistatic fabric softeners for clothes dryers**
- Masonry acid washing materials**

All gas-fired appliances require air for the combustion process. If sufficient combustion air is not available, the furnace or other appliances will operate inefficiently and unsafely. Enough air must be provided to meet the needs of all fuel-burning appliances and appliances such as exhaust

fans which force air out of the house. When fireplaces, exhaust fans, or clothes dryers are used at the same time as the furnace, much more air is necessary to ensure proper combustion and to prevent a downdraft. Insufficient air causes incomplete combustion which can result in carbon monoxide.

In addition to providing combustion air, fresh outdoor air dilutes contaminants in the indoor air. These contaminants may include bleaches, adhesives, detergents, solvents and other contaminants which can corrode furnace components.

The requirements for providing air for combustion and ventilation depend largely on whether the furnace is installed in an unconfined or a confined space.

Unconfined Space

An unconfined space is an area such as a basement or large equipment room with a volume greater than 50 cubic feet (1.42 m³) per 1,000 Btu (.29 kW) per hour of the combined input rating of all appliances installed in that space. This space also includes adjacent rooms which are not separated by a door. Though an area may appear to be unconfined, it might be necessary to bring in outdoor air for combustion if the structure does not provide enough air by infiltration. If the furnace is located in a building of tight construction with weather stripping and caulking around the windows and doors, follow the procedures in the air from outside section.

Confined Space

A confined space is an area with a volume less than 50 cubic feet (1.42 m³) per 1,000 Btu (.29 kW) per hour of the combined input rating of all appliances installed in that space. This definition includes furnace closets or small equipment rooms.

When the furnace is installed so that supply ducts carry air circulated by the furnace to areas outside the space containing the furnace, the return air must be handled by ducts which are sealed to the furnace casing and which terminate outside the space containing the furnace. This is especially important when the furnace is mounted on a platform in a confined space such as a closet or small equipment room. Even a small leak around the base of the unit at the platform or at the return air duct connection can cause a potentially negative pressure condition. Air for combustion and dangerous ventilation can be brought into the confined space either from inside the building or from outside.

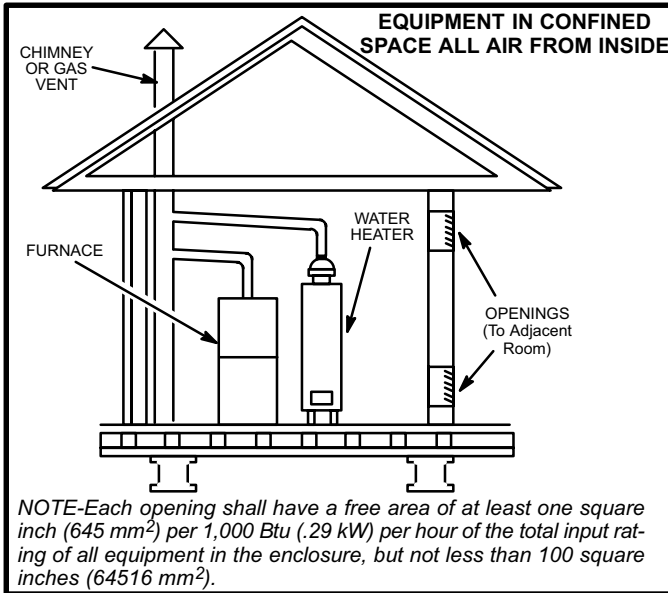

FIGURE 2

Air from Inside

If the confined space that houses the furnace adjoins a space categorized as unconfined, air can be brought in by providing two permanent openings between the two spaces. Each opening must have a minimum free area of 1 square inch (645 mm²) per 1,000 Btu (.29 kW) per hour of total input rating of all gas-fired equipment in the confined space. Each opening must be at least 100 square inches (64516 mm²). One opening shall be within 12 inches (305

mm) of the top of the enclosure and one opening within 12 inches (305 mm) of the bottom. See figure 2.

Air from Outside

If air from outside is brought in for combustion and ventilation, the confined space must have two permanent openings. One opening shall be within 12 inches (305 mm) of the top of the enclosure and one opening within 12 inches (305 mm) of the bottom. These openings must communicate directly or by ducts with the outdoors or spaces (crawl or attic) that freely communicate with the outdoors or indirectly through vertical ducts. Each opening shall have a minimum free area of 1 square inch (645 mm²) per 4,000 Btu (1.17 kW) per hour of total input rating of all equipment in the enclosure. See figures 3 and 4. When communicating with the outdoors through horizontal ducts, each opening shall have a minimum free area of 1 square inch (645 mm²) per 2,000 Btu (.56 kW) per total input rating of all equipment in the enclosure. See figure 5.

When ducts are used, they shall be of the same cross-sectional area as the free area of the openings to which they connect. The minimum dimension of rectangular air ducts shall be no less than 3 inches (75 mm). In calculating free area, the blocking effect of louvers, grilles, or screens must be considered. If the design and free area of protective covering is not known for calculating the size opening required, it may be assumed that wood louvers will have 20 to 25 percent free area and metal louvers and grilles will have 60 to 75 percent free area. Louvers and grilles must be fixed in the open position or interlocked with the equipment so that they are opened automatically during equipment operation.

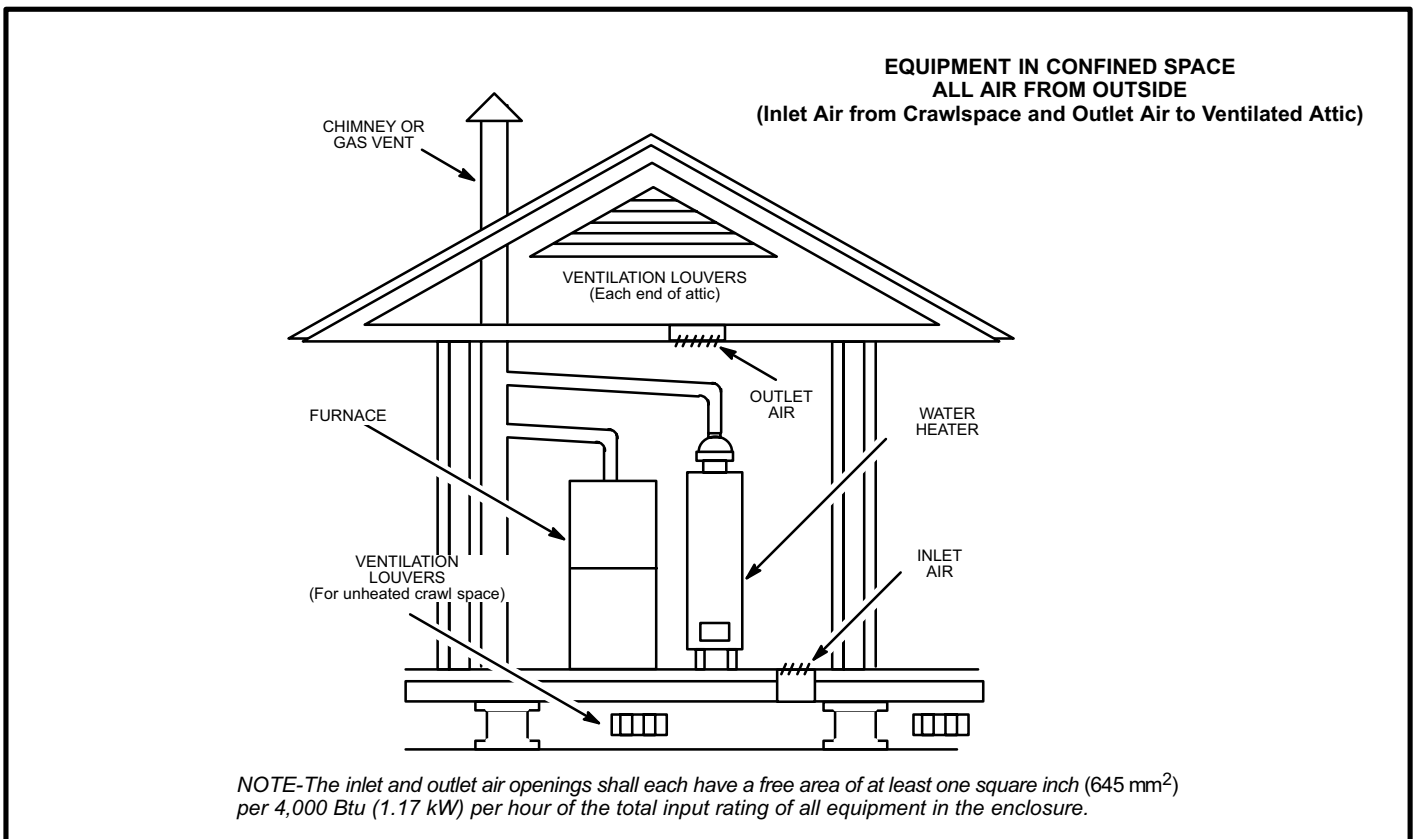

FIGURE 3

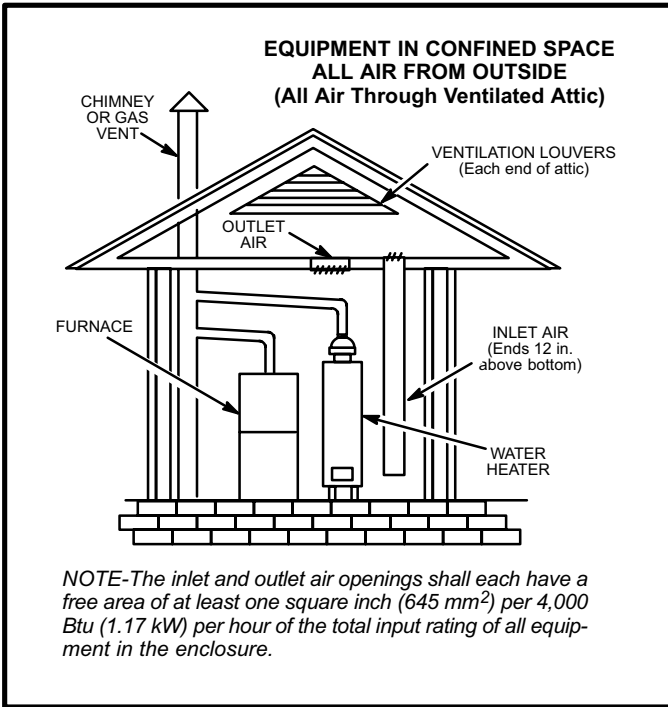

FIGURE 4

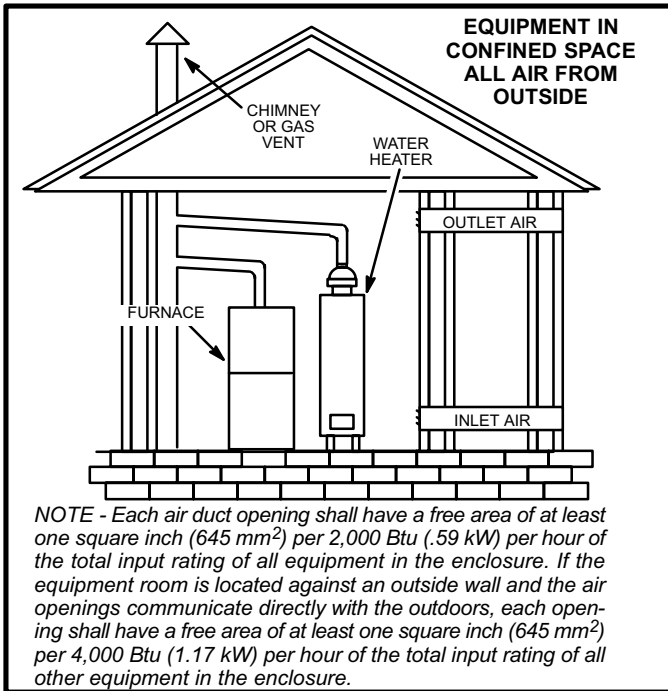

FIGURE 5

Setting Equipment

⚠ WARNING

Do not install the furnace on its front or its back. Do not connect the return air ducts to the back of the furnace. Doing so will adversely affect the operation of the safety control devices, which could result in personal injury or death.

The G40UH(X) gas furnace can be installed as shipped in either the upflow position or the horizontal position, with right-hand or left-hand air discharge.

Select a location that allows for the required clearances that are listed on the unit nameplate. Also consider gas supply connections, electrical supply, vent connection, and installation and service clearances [24 inches (610 mm) at unit front]. *The unit must be level.*

NOTE - 1/3 hp blower motors are equipped with four flexible mounting legs, and 1/2 hp blower motors are equipped with three flexible legs and one rigid leg. The rigid leg is equipped with a shipping bolt and a flat white plastic washer (rather than the rubber mounting grommet used with a flexible mounting leg). **The bolt and washer must be removed before the furnace is placed into operation.** After the bolt and washer have been removed, the rigid leg will not touch the blower housing.

Upflow Applications

Allow for clearances to combustible materials as indicated on the unit nameplate. Minimum clearances for closet or alcove installations are shown in figure 6.

Upflow Application Installation Clearances

Type of Vent Connector	Type C	Type B1
Top	1 in. (25 mm)	1 in. (25 mm)
*Front	3 in. (76 mm)	3 in. (76 mm)
Back	0	0
Sides	0†	0
Vent	6 in. (152 mm)	1 in. (25 mm)
Floor	0‡	0‡

*Front clearance in alcove installation must be 24 in. (610 mm). Maintain a minimum of 24 in. (610 mm) for front service access.
 ‡For installations on a combustible floor, do not install the furnace directly on carpeting, tile or other combustible materials other than wood flooring.
 †Left side requires 3 inches if a single wall vent is used on 14-1/2 inch cabinets, or 2 inches if a single wall vent is used on 17-1/2 inch cabinets.

FIGURE 6

Return Air -- Upflow Applications

Return air can be brought in through the bottom or either side of the furnace installed in an upflow application. If the furnace is installed on a platform with bottom return, make an airtight seal between the bottom of the furnace and the platform to ensure that the furnace operates properly and safely. The furnace is equipped with a removable bottom panel to facilitate installation.

Markings are provided on both sides of the furnace cabinet for installations that require side return air. Cut the furnace cabinet at the maximum dimensions shown on page 2.

NOTE - When air volumes over 1800 cfm (850 L/s) are required with 60C or 60D models in an upflow application, the following return air options are available:

- 1 - Return air from single side with transition which will accommodate 20 x 25 x 1 in. (508 x 635 x 25 mm) cleanable air filter. (Required to maintain proper air velocity.) See figure 7.
- 2 - Return air from single side with optional RAB Return Air Base. See figure 8.
- 3 - Return air from bottom.
- 4 - Return air from both sides.

5 - Return air from bottom and one side.

Refer to Engineering Handbook for additional information.

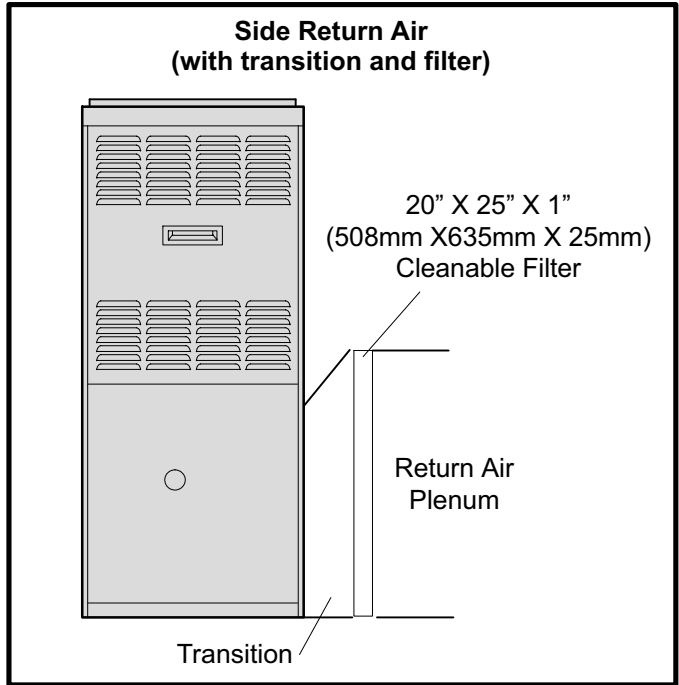
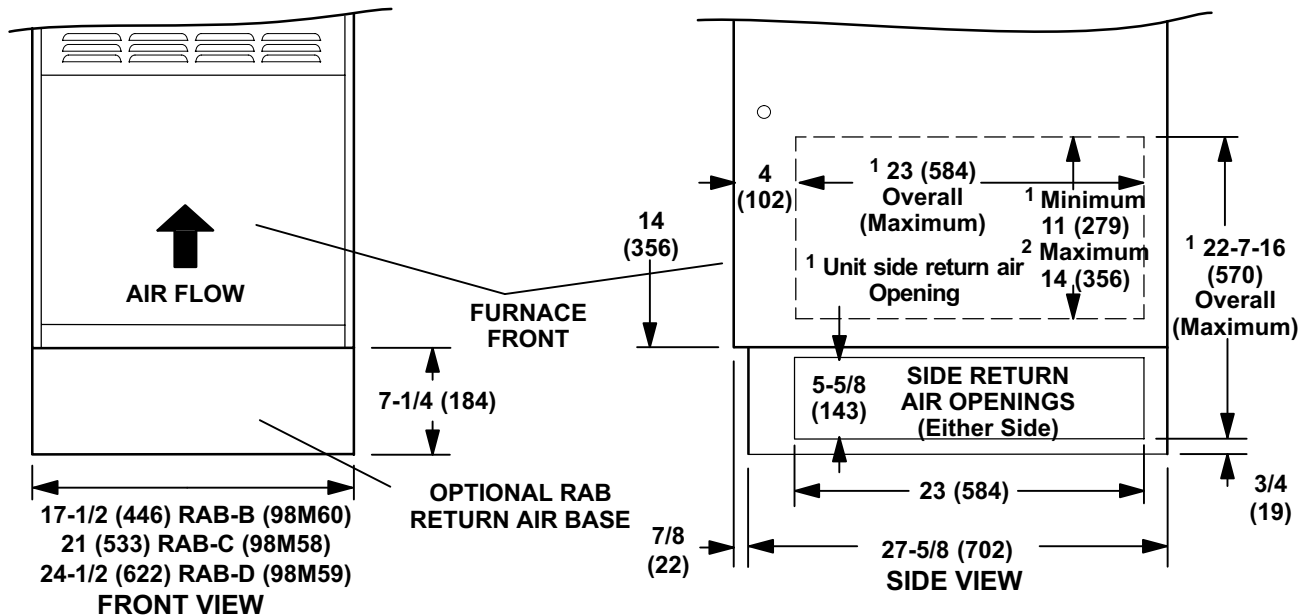

FIGURE 7

Optional Return Air Base (Upflow Applications Only -- For use with B, C and D cabinets only)



NOTE- Optional Side Return Air Filter Kits are not for use with RAB Return Air Base.

¹ Both the unit return air opening and the base return air opening must be covered by a single plenum or IAQ cabinet. Minimum unit side return air opening dimensions for units requiring 1800 cfm or more of air (W x H): 23 x 11 in. (584 x 279 mm).

The opening can be cut as needed to accommodate plenum or IAQ cabinet while maintaining dimensions shown.

Side return air openings must be cut in the field. There are cutting guides stenciled on the cabinet for the side return air opening. The size of the opening must not extend beyond the markings on the furnace cabinet..

² To minimize pressure drop, the largest opening height possible (up to 14 inches) is preferred.

NOTE- Optional Side Return Air Filter Kits are not for use with RAB Return Air Base.

FIGURE 8

Removing the Bottom Panel

Remove the two screws that secure the bottom cap to the furnace. Pivot the bottom cap down to release the bottom panel. Once the bottom panel has been removed, reinstall the bottom cap. See figure 9.

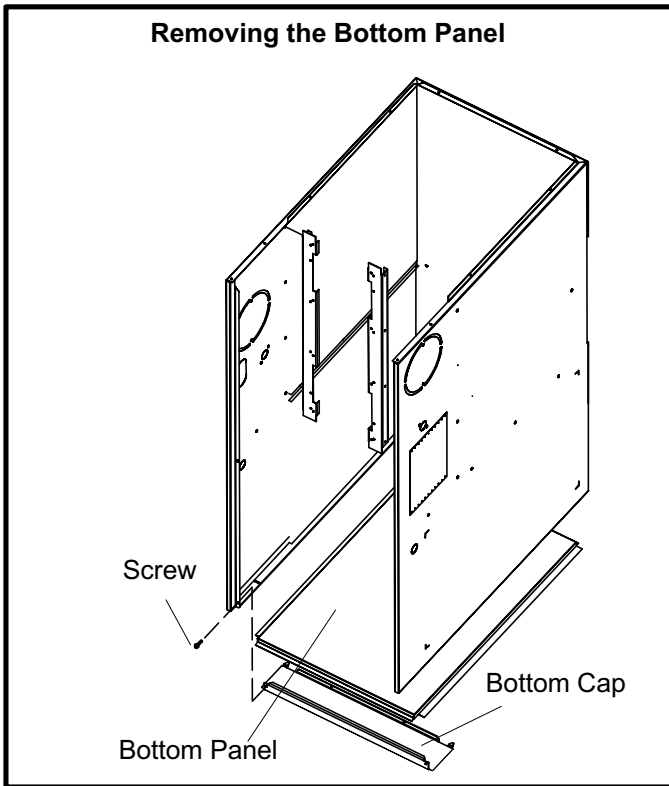

FIGURE 9

Leveling an Upflow Unit

When the side return air inlets are used in an upflow application, it may be necessary to install leveling bolts on the bottom of the furnace. Use field-supplied corrosion-resistant 5/16 inch machine bolts (4) and nuts (8). See figure 10. *NOTE - The maximum length of the bolt is 1-1/2 inches.*

- 1 - Lie the furnace on its back and drill a 5/16 inch diameter hole in each corner of the furnace's bottom. See figure 10 for the correct location of the holes. Drill through the bottom panel and the bottom flange of the cabinet.
- 2 - Install one bolt and two nuts into each hole. Screw the first nut onto a bolt and then insert the bolt into a hole. A flat washer may be added between the nut and the bottom of the unit.
- 3 - Screw another nut onto the bolt on the inside of the furnace base. A flat washer may be added between the nut and the bottom of the unit.
- 4 - Adjust the outside nut to the appropriate height and tighten the inside nut to secure the arrangement.

NOTE - The unit may be tilted back-to-front a maximum of 1". This will ensure proper draining of the heat exchanger.

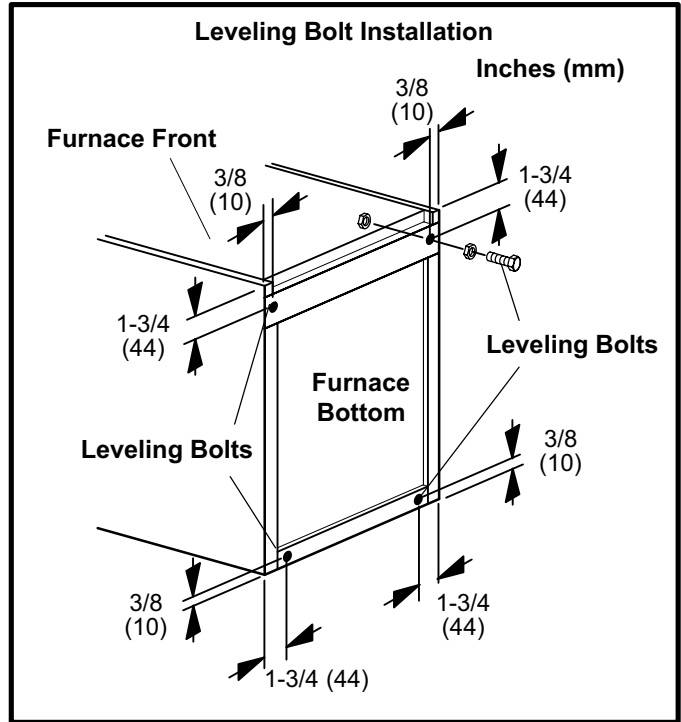

FIGURE 10

Horizontal Applications

The G40UH(X) furnace can be installed in horizontal applications.

Allow for clearances to combustibles as indicated on the unit nameplate. Minimum clearances for closet or alcove installations are shown in figure 11.

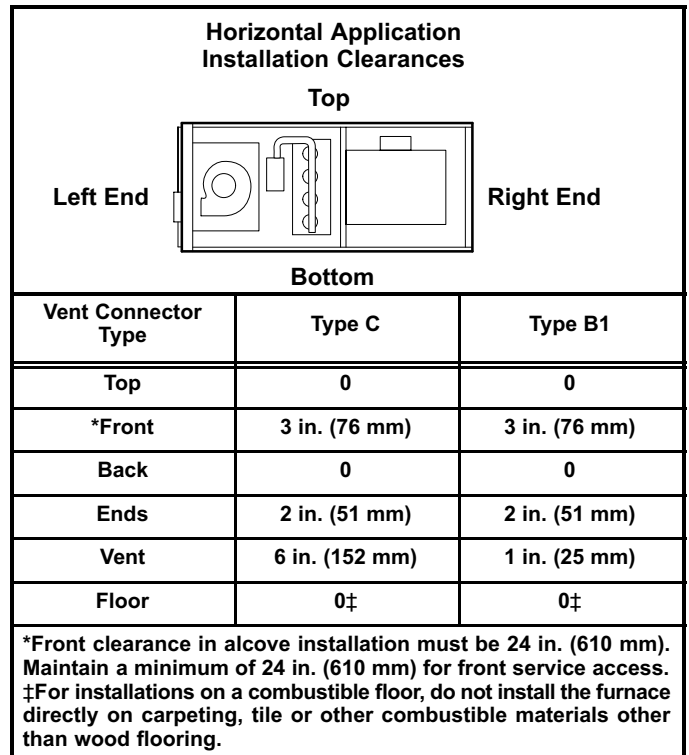

FIGURE 11

This furnace may be installed in either an attic or a crawlspace. Either suspend the furnace from roof rafters or floor joists, as shown in figure 12, or install the furnace on a platform, as shown in figure 13. The unit must be supported at both ends and beneath the blower deck to prevent sagging.

NOTE - In horizontal applications, the unit must be level side to side. The unit may be tilted back to front a maximum of 1". This will ensure proper draining of the heat exchanger.

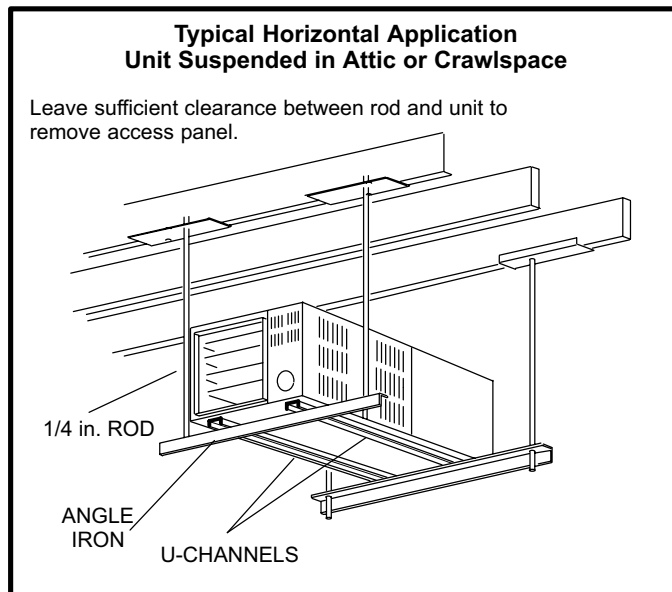

FIGURE 12

NOTE - Heavy gauge perforated sheet metal straps (plumbers' straps) may be used to suspend the unit from roof rafters or ceiling joists. When straps are used to suspend the unit in this way, support must be provided for both the ends and the middle of the furnace to prevent sagging. The straps must not interfere with the plenum or exhaust piping installation. Securing screws should be 1/2 inch from the top edge and 1-1/2 inch from the side edge in all cases. Cooling coils and supply and return air plenums must be supported separately.

NOTE - When the furnace is installed on a platform in a crawlspace, it must be elevated enough to avoid water damage and to allow the evaporator coil to drain.

Return Air -- Horizontal Applications

Return air can be brought in through the end of a furnace installed in a horizontal application. The furnace is equipped with a removable bottom panel to facilitate installation. See figure 9.

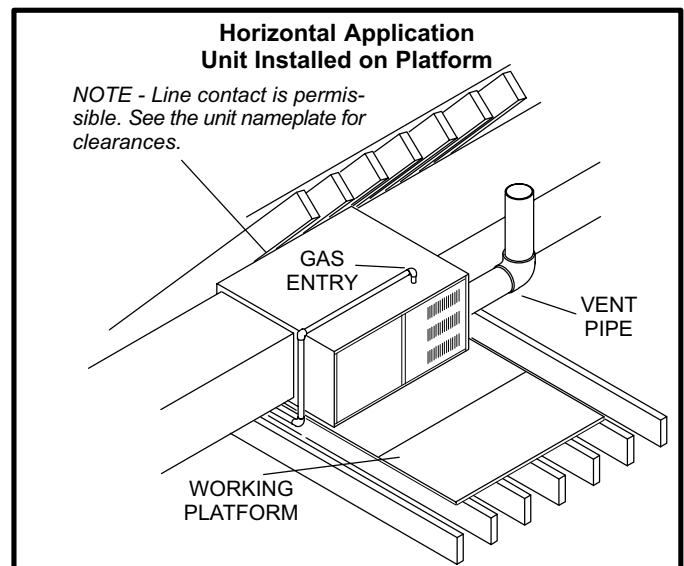

FIGURE 13

⚠ WARNING

Improper installation of the furnace can result in personal injury or death. Combustion and flue products must never be allowed to enter the return air system or the living space. Use screws and joint tape to seal the return air system to the furnace.

In platform installations with bottom return air, the furnace should be sealed airtight to the return air plenum. A door must never be used as a portion of the return air duct system. The base must provide a stable support and an airtight seal to the furnace. Allow absolutely no sagging, cracks, gaps, etc.

The return and supply air duct systems must never be connected to or from other heating devices such as a fireplace or stove, etc. Fire, explosion, carbon monoxide poisoning, personal injury and/or property damage could result.

⚠ WARNING

The blower access panel must be securely in place when the blower and burners are operating. Gas fumes, which could contain carbon monoxide, can be drawn into living space resulting in personal injury or death.

Filters

This unit is not equipped with a filter or rack. A field-provided high-velocity filter is required for the unit to operate properly. Table 1 lists recommended filter sizes.

A filter must be in place whenever the unit is operating.

TABLE 1

Furnace Cabinet Size	Filter Size	
	Side Return	Bottom Return
14-1/2"	16 X 25 X 1 (1)	14 X 25 X 1 (1)
17-1/2"	16 X 25 X 1 (1)	16 X 25 X 1 (1)
21"	16 X 25 X 1 (1)	20 X 25 X 1 (1)
24-1/2"	16 X 25 X 1 (2)	24 X 25 X 1 (1)

Duct System

Use industry-approved standards to size and install the supply and return air duct system. This will result in a quiet and low-static system that has uniform air distribution.

NOTE - Do not operate the furnace with an external static pressure that exceeds 0.5 inches w.c. Higher external static pressures may cause erratic limit operation.

Supply Air Plenum

If the furnace is installed without a cooling coil, a removable access panel must be installed in the supply air duct. The access panel should be large enough to permit inspection (either by smoke or reflected light) of the heat exchanger for leaks after the furnace is installed. The furnace access panel must always be in place when the furnace is operating and it must not allow leaks into the supply air duct system.

Return Air Plenum

Return air must not be drawn from a room where this furnace, or any other gas appliance (ie., a water heater), is installed. When return air is drawn from a room, a negative pressure is created in the room. If a gas appliance is operating in a room with negative pressure, the flue products can be pulled back down the vent pipe and into the room. This reverse flow of the flue gas may result in incomplete combustion and the formation of carbon monoxide gas. This toxic gas might then be distributed throughout the house by the furnace duct system.

In upflow applications, the return air can be brought in through the bottom or either side of the furnace. If a furnace with bottom return air is installed on a platform, make an airtight seal between the bottom of the furnace and the platform to ensure that the unit operates properly and safely. Use fiberglass sealing strips, caulking, or equivalent sealing method between the plenum and the furnace cabinet to ensure a tight seal. If a filter is installed, size the return air duct to fit the filter frame.

Venting

A 4-inch diameter flue transition is factory-installed on the combustion air inducer outlet of all models. **Modifying or removing the flue transition will cause the unit to operate unsafely and will void the unit certification.** The vent connector does not require insulation.

The combustion air inducer may be rotated clockwise or counterclockwise by 90° to allow for vertical vent discharge. Remove the four mounting screws, rotate the assembly (including the gasket), then reinstall the mounting screws. See figure 14. Use the provided wire tie to bundle the pressure switch wires with the inducer motor power leads. **Route the power leads away from any moving parts to prevent damage to the wires.**

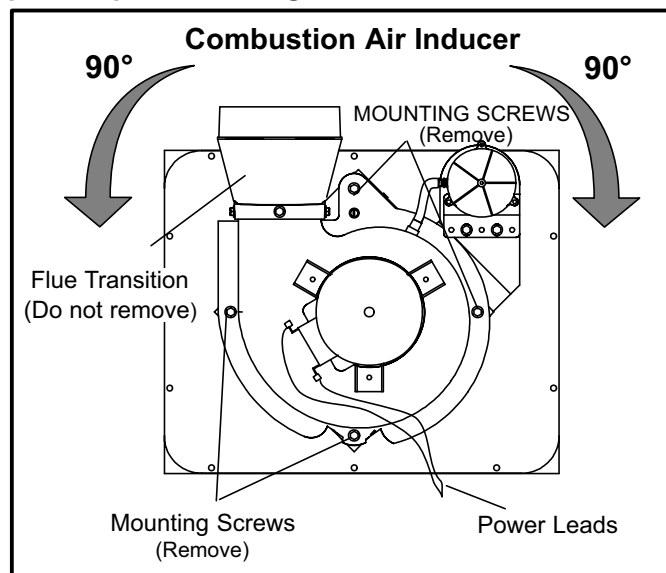

FIGURE 14

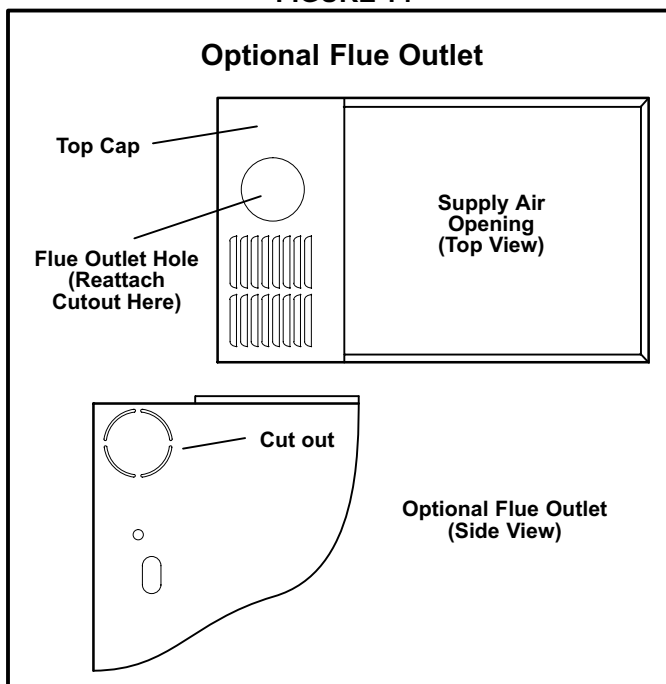

FIGURE 15

Use sheet metal shears to remove the cut out from the side of the cabinet. Use the two provided sheet metal screws to install the cut out on the top cap to cover the original flue outlet opening. See figure 15.

The G40UH(X) series units are classified as fan-assisted Category I furnaces when vertically vented according to the latest edition of the National Fuel Gas Code (NFPA 54/ ANSI Z223.1) in the USA and the current CSA B149 Natural Gas and Propane Installation Codes in Canada. A fan-assisted Category I furnace is an appliance equipped with an integral mechanical means to either draw or force combustion products through the combustion chamber and/or heat exchanger.

NOTE - Use these instructions as a guide. They do not supersede local codes. This furnace must be vented according to all local codes these installation instructions, and the provided venting tables in these instructions

The venting tables in this manual were extracted from the National Fuel Gas Code (NFPA 54 / ANSI Z223.1) and are provided as a guide for proper vent installation. Proper application, termination, construction and location of vents must conform to local codes having jurisdiction. In the absence of local codes, the NFGC serves as the defining document.

Refer to the tables and the venting information contained in these instructions to properly size and install the venting system.

▲ IMPORTANT

Once the venting system is installed, attach the "Disconnected Vent" warning sticker to a visible area of the plenum near the vent pipe. The warning sticker is provided in the bag assembly.

▲ WARNING

Asphyxiation hazard. The exhaust vent for this furnace must be securely connected to the furnace flue transition at all times.

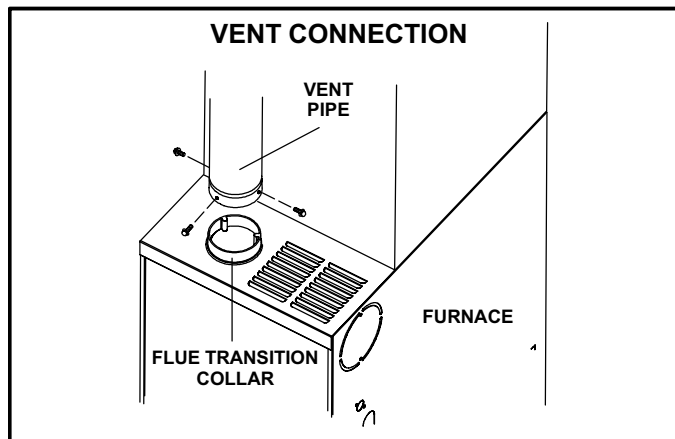

FIGURE 16

Use self-drilling sheet metal screws or a mechanical fastener to firmly secure the vent pipe to the round collar of the flue transition. If self-drilling screws are used to attach the vent pipe, it is recommended that three be used. Drive one self-drilling screw through the front and one through each side of the vent pipe and collar. See figure 16.

Install the first vent connector elbow at a minimum of six inches (152 mm) from the furnace vent outlet.

Venting Using a Masonry Chimney

The following additional requirements apply when a lined masonry chimney is used to vent this furnace.

Masonry chimneys used to vent Category I central furnaces must be either tile-lined or lined with a listed metal lining system or dedicated gas vent. Unlined masonry chimneys are prohibited. See figures 17 and 18 for common venting.

A chimney with one or more sides exposed to the outside of the structure is considered to be an exterior chimney.

An exterior masonry chimney that is not tile-lined must be lined with B1 vent or a listed insulated flexible metal vent. An exterior tile-lined chimney that is sealed and capped may be lined with a listed uninsulated flexible metal vent.

If the existing chimney will not accommodate a listed metal liner, either the chimney must be rebuilt to accommodate one of these liners or an alternate approved venting method must be found.

Insulation for the flexible vent pipe must be an encapsulated fiberglass sleeve recommended by the flexible vent pipe manufacturer. See figure 17.

DO NOT insulate the space between the liner and the chimney wall with puffed mica or any other loose granular insulating material

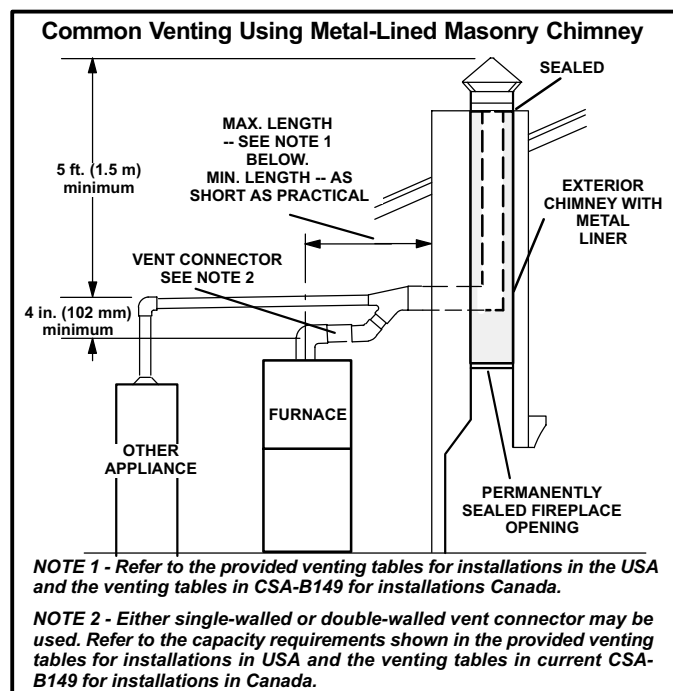
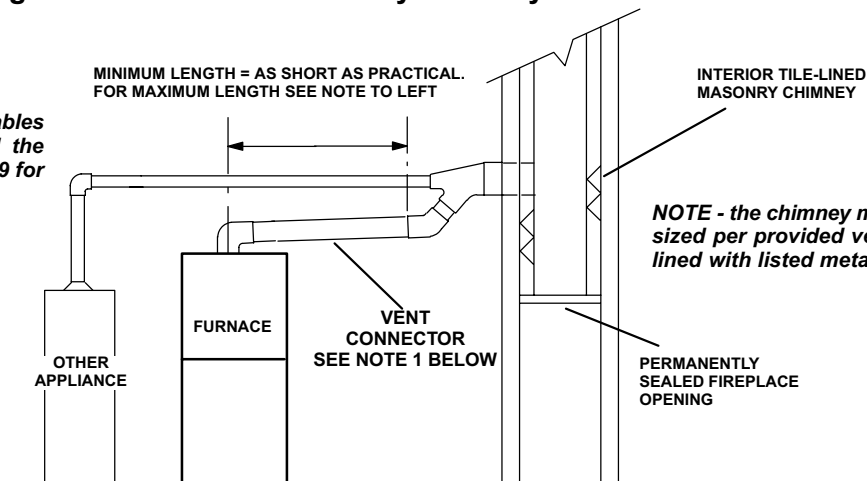

FIGURE 17

Common Venting Using Tile-Lined Interior Masonry Chimney and Combined Vent Connector

NOTE- Refer to provided venting tables for installations in the USA and the venting tables in current CSA-B149 for installations in Canada.



NOTE - the chimney must be properly sized per provided venting tables or lined with listed metal lining system.

Note - Either single-walled or double-walled vent connector may be used. Refer to the capacity requirements as shown in the provided venting tables for installations in USA and the venting tables in current CSA-B149 for installations in Canada.

FIGURE 18

⚠ IMPORTANT

SINGLE appliance venting of a fan-assisted furnace into a tile-lined masonry chimney (interior or outside wall) is PROHIBITED. The chimney must first be lined with either type B1 vent or an insulated single wall flexible vent lining system which has been sized according to the provided venting tables and the vent pipe manufacturer's instructions.

A fan-assisted furnace may be commonly vented into an existing lined masonry chimney if the following conditions are met:

- The chimney is currently serving at least one draft hood equipped appliance.
- The vent connectors and chimney are sized according to the provided venting tables for the USA, and the appropriate venting tables in the standards of CSA B149 Natural Gas and Propane Installation Codes in Canada

If type B1 double-wall vent is used inside a chimney, no other appliance can be vented into the chimney. The outer wall of type B1 vent pipe must not be exposed to flue products.

A type B1 vent or masonry chimney liner shall terminate above the roof surface with a listed cap or a listed roof assembly according to the terms of their respective listings and the vent manufacturer's instructions.

When inspection reveals that an existing chimney is not safe for the intended purpose, it shall be rebuilt to conform to nationally recognized standards, lined or relined with suitable materials, or replaced with a gas vent or chimney suitable for venting G40UH(X) series units. The chimney passageway must be checked periodically to ensure that it is clear and free of obstructions.

Do not install a manual damper, barometric draft regulator, or flue restrictor between the furnace and the chimney.

Never connect a Category I appliance to a chimney that is servicing a solid-fuel appliance. If a fireplace chimney flue is used to vent this appliance, the fireplace opening must be permanently sealed.

A type B or listed chimney lining system that passes through an unused masonry chimney flue is not considered to be exposed to the outdoors.

General Venting Requirements

Vent all G40UH(X) furnaces according to these instructions:

- 1 - Vent diameter recommendations and maximum allowable piping runs are found in the provided venting tables for the USA, and the appropriate venting tables in the standards of CSA B149 Natural Gas and Propane Installation Codes for Canada.
- 2 - In no case should the vent or vent connector diameter be less than the diameter specified in the provided venting tables for the USA, and the appropriate venting tables in the standards of CSA B149 Natural Gas and Propane Installation Code for Canada.
- 3 - *Single appliance vents* - If the vertical vent or tile-lined chimney has a larger diameter or flow area than the vent connector, use the **vertical vent diameter** to determine the **minimum vent capacity** and the **vent connector diameter** to determine the **maximum vent capacity**. The flow area of the vertical vent, however, shall not exceed 7 times the flow area of the listed appliance categorized vent area, draft hood outlet area or flue collar area unless designed according to approved engineering methods.
- 4 - *Multiple appliance vents* - The flow area of the largest section of vertical vent or chimney shall not exceed 7 times the smallest listed appliance categorized vent area, draft hood outlet area or flue collar area unless designed according to approved engineering methods.

- 5 - The entire length of single wall metal vent connector shall be readily accessible for inspection, cleaning, and replacement.
- 6 - Single appliance venting configurations with zero lateral lengths (tables 3 and 4), are assumed to have no elbows in the vent system. For all other vent configurations, the vent system is assumed to have two 90° elbows. For each additional 90° elbow or equivalent (for example two 45° elbows equal one 90° elbow) beyond two, the maximum capacity listed in the venting table should be reduced by 10% (0.90 x maximum listed capacity).
- 7 - The common venting tables (5, 6, 7, and 8) were generated using a maximum horizontal vent connector length of 1-1/2 feet (.46 m) for each inch (25 mm) of connector diameter as follows:

TABLE 2

Connector Diameter inches (mm)	Maximum Horizontal Connector Length feet (m)
3 (76)	4-1/2 (1.37)
4 (102)	6 (1.83)
5 (127)	7-1/2 (2.29)
6 (152)	9 (2.74)
7 (178)	10-1/2 (3.20)

- 8 - If the common vertical vent is offset, the maximum common vent capacity listed in the common venting tables should be reduced by 20%, the equivalent of two 90° elbows (0.80 x maximum common vent capacity). The horizontal length of the offset shall not exceed 1-1/2 feet (.46 m) for each inch (25 mm) of common vent diameter.
- 9 - The vent pipe should be as short as possible with the least number of elbows and angles required to complete the job. Route the vent connector to the vent using the shortest possible route.
- 10 - A vent connector shall be supported without any dips or sags and shall slope a minimum of 1/4 inch (6.4 mm) per linear foot (305 mm) of connector, back toward the appliance.
- 11 - Vent connectors shall be firmly attached to the furnace flue collars by self-drilling screws (three recom-

- mended) or other approved means, except vent connectors of listed type B vent material which shall be assembled according to the manufacturer's instructions. Joints between sections of single wall connector piping shall be fastened by screws or other approved means.
- 12 - When the vent connector used for Category I appliances must be located in or pass through a crawlspace or other areas which may be cold, that portion of the vent connector shall be constructed of listed double-wall type B vent material or material having equivalent insulation qualities.
- 13 - All venting pipe passing through floors, walls, and ceilings must be installed with the listed clearance to combustible materials and be fire stopped according to local codes. In absence of local codes, refer to NFGC (Z223.1).
- 14 - No portion of the venting system can extend into, or pass through any circulation air duct or plenum.
- 15 - Vent connectors serving Category I appliances shall not be connected to any portion of mechanical draft systems operating under positive pressure such as Category III or IV venting systems.
- 16 - If vent connectors are combined prior to entering the common vent, the maximum common vent capacity listed in the common venting tables must be reduced by 10%, the equivalent of one 90° elbow (0.90 x maximum common vent capacity).
- 17 - The common vent diameter must always be at least as large as the largest vent connector diameter.
- 18 - In no case, shall the vent connector be sized more than two consecutive table size diameters over the size of the draft hood outlet or flue collar outlet.
- 19 - Do not install a manual damper, barometric draft regulator or flue restrictor between the furnace and the chimney.
- 20 - When connecting this appliance to an existing dedicated or common venting system, you must inspect the venting system's general condition and look for signs of corrosion. The existing vent pipe size must conform to these instructions and the provided venting tables for the USA, and the appropriate venting tables in the standards of CSA B149 Natural Gas and Propane Installation Codes for Canada. If the existing venting system does not meet these requirements, it must be resized.

TABLE 3
Capacity of Type B Double-Wall Vents with Type B Double-Wall Connectors
Serving a Single Category I Appliance

Height H (feet)	Lateral L (feet)	Vent and Connector Diameter - D (inches)							
		3 Inch		4 Inch		5 Inch		6 Inch	
		Appliance Input Rating in Thousands of Btu Per Hour							
		MIN	MAX	MIN	MAX	MIN	MAX	MIN	MAX
6	0	0	78	0	152	0	251	0	375
	2	13	51	18	97	27	157	32	232
	4	21	49	30	94	39	153	50	227
	6	25	46	36	91	47	149	59	223
8	0	0	84	0	165	0	276	0	415
	2	12	57	16	109	25	178	28	263
	5	23	53	32	103	42	171	53	255
	8	28	49	39	98	51	164	64	247
10	0	0	88	0	175	0	295	0	447
	2	12	61	17	118	23	194	26	289
	5	23	57	32	113	41	187	52	280
	10	30	51	41	104	54	176	67	267
15	0	0	94	0	191	0	327	0	502
	2	11	69	15	136	20	226	22	339
	5	22	65	30	130	39	219	49	330
	10	29	59	40	121	51	206	64	315
	15	35	53	48	112	61	195	76	301
20	0	0	97	0	202	0	349	0	540
	2	10	75	14	149	18	250	20	377
	5	21	71	29	143	38	242	47	367
	10	28	64	38	133	50	229	62	351
	15	34	58	46	124	59	217	73	337
	20	48	52	55	116	69	206	84	322
30	0	0	100	0	213	0	374	0	587
	2	9	81	13	166	14	283	18	432
	5	21	77	28	160	36	275	45	421
	10	27	70	37	150	48	262	59	405
	15	33	64	44	141	57	249	70	389
	20	56	58	53	132	66	237	80	374
	30	NR	NR	73	113	88	214	104	346

NOTE - Single appliance venting configurations with zero lateral lengths are assumed to have no elbows in the vent system. For all other vent configurations, the vent system is assumed to have two 90° elbows. For each additional 90° elbow or equivalent (for example two 45° elbows equal one 90° elbow) beyond two, the maximum capacity listed in the venting table should be reduced by 10 percent (0.90 x maximum listed capacity).

TABLE 4
Capacity of Type B Double-Wall Vents with Single-Wall Metal Connectors
Serving a Single Category I Appliance

Height H (feet)	Lateral L (feet)	Vent and Connector Diameter - D (inches)							
		3 Inch		4 Inch		5 Inch		6 Inch	
		Appliance Input Rating in Thousands of Btu Per Hour							
		MIN	MAX	MIN	MAX	MIN	MAX	MIN	MAX
6	0	38	77	59	151	85	249	126	373
	2	39	51	60	96	85	156	123	231
	4	NR	NR	74	92	102	152	146	225
	6	NR	NR	83	89	114	147	163	220
8	0	37	83	58	164	83	273	123	412
	2	39	56	59	108	83	176	121	261
	5	NR	NR	77	102	107	168	151	252
	8	NR	NR	90	95	122	161	175	243
10	0	37	87	57	174	82	293	120	444
	2	39	61	59	117	82	193	119	287
	5	52	56	76	111	105	185	148	277
	10	NR	NR	97	100	132	171	188	261
15	0	36	93	56	190	80	325	116	499
	2	38	69	57	136	80	225	115	337
	5	51	63	75	128	102	216	144	326
	10	NR	NR	95	116	128	201	182	308
	15	NR	NR	NR	NR	158	186	220	290
20	0	35	96	54	200	78	346	114	537
	2	37	74	56	148	78	248	113	375
	5	50	68	73	140	100	239	141	363
	10	NR	NR	93	129	125	223	177	344
	15	NR	NR	NR	NR	155	208	216	325
	20	NR	NR	NR	NR	186	192	254	306
30	0	34	99	53	211	76	372	110	584
	2	37	80	55	164	76	281	109	429
	5	49	74	72	157	98	271	136	417
	10	NR	NR	91	144	122	255	171	397
	15	NR	NR	115	131	151	239	208	377
	20	NR	NR	NR	NR	181	223	246	357
	30	NR	NR	NR	NR	NR	NR	NR	NR

NOTE - Single appliance venting configurations with zero lateral lengths are assumed to have no elbows in the vent system. For all other vent configurations, the vent system is assumed to have two 90° elbows. For each additional 90° elbow or equivalent (for example two 45° elbows equal one 90° elbow) beyond two, the maximum capacity listed in the venting table should be reduced by 10 percent (0.90 x maximum listed capacity).

TABLE 5
Vent Connector Capacity
Type B Double-Wall Vents with Type B Double-Wall Connectors
Serving Two or More Category I Appliances

Vent Height H (feet)	Connector Rise R (feet)	Vent and Connector Diameter - D (inches)							
		3 Inch		4 Inch		5 Inch		6 Inch	
		Appliance Input Rating in Thousands of Btu Per Hour							
		MIN	MAX	MIN	MAX	MIN	MAX	MIN	MAX
6	1	22	37	35	66	46	106	58	164
	2	23	41	37	75	48	121	60	183
	3	24	44	38	81	49	132	62	199
8	1	22	40	35	72	49	114	64	176
	2	23	44	36	80	51	128	66	195
	3	24	47	37	87	53	139	67	210
10	1	22	43	34	78	49	123	65	189
	2	23	47	36	86	51	136	67	206
	3	24	50	37	92	52	146	69	220
15	1	21	50	33	89	47	142	64	220
	2	22	53	35	96	49	153	66	235
	3	24	55	36	102	51	163	68	248
20	1	21	54	33	99	46	157	62	246
	2	22	57	34	105	48	167	64	259
	3	23	60	35	110	50	176	66	271
30	1	20	62	31	113	45	181	60	288
	2	21	64	33	118	47	190	62	299
	3	22	66	34	123	48	198	64	309

TABLE 6
Common Vent Capacity
Type B Double-Wall Vents with Type B Double-Wall Connectors
Serving Two or More Category I Appliances

Vent Height H (feet)	Common Vent Diameter - D (inches)							
	4 Inch		5 Inch		6 Inch		7 Inch	
	Appliance Input Rating in Thousands of Btu Per Hour							
	FAN + FAN	FAN + NAT	FAN + FAN	FAN + NAT	FAN + FAN	FAN + NAT	FAN + FAN	FAN + NAT
6	92	81	140	116	204	161	309	248
8	101	90	155	129	224	178	339	275
10	110	97	169	141	243	194	367	299
15	125	112	195	164	283	228	427	352
20	136	123	215	183	314	255	475	394
30	152	138	244	210	361	297	547	459

TABLE 7
Vent Connector Capacity
Type B Double-Wall Vents with Single-Wall Metal Connectors
Serving Two or More Category I Appliances

Vent Height H (feet)	Connector Rise R (feet)	Vent and Connector Diameter - D (inches)							
		3 Inch		4 Inch		5 Inch		6 Inch	
		Appliance Input Rating in Thousands of Btu Per Hour							
		MIN	MAX	MIN	MAX	MIN	MAX	MIN	MAX
6	1	NR	NR	NR	NR	NR	NR	NR	NR
	2	NR	NR	NR	NR	NR	NR	168	182
	3	NR	NR	NR	NR	121	131	174	198
15	1	NR	NR	79	87	116	138	177	214
	2	NR	NR	83	94	121	150	185	230
	3	NR	NR	87	100	127	160	193	243
30	1	47	60	77	110	113	175	169	278
	2	50	62	81	115	117	185	177	290
	3	54	64	85	119	122	193	185	300

TABLE 8
Common Vent Capacity
Type B Double-Wall Vents with Single-Wall Metal Connectors
Serving Two or More Category I Appliances

Vent Height H (feet)	Common Vent Diameter - D (inches)							
	4 Inch		5 Inch		6 Inch		7 Inch	
	Appliance Input Rating in Thousands of Btu Per Hour							
	FAN + FAN	FAN + NAT	FAN + FAN	FAN + NAT	FAN + FAN	FAN + NAT	FAN + FAN	FAN + NAT
6	89	78	136	113	200	158	304	244
8	98	87	151	126	218	173	331	269
10	106	94	163	137	237	189	357	292
15	121	108	189	159	275	221	416	343
20	131	118	208	177	305	247	463	383
30	145	132	236	202	350	286	533	446

Removal of the Furnace from Common Vent

In the event that an existing furnace is removed from a venting system commonly run with separate gas appliances, the venting system is likely to be too large to properly vent the remaining attached appliances.

Conduct the following test while each appliance is operating and the other appliances (which are not operating) remain connected to the common venting system. If the venting system has been installed improperly, you **must** correct the system as indicated in the general venting requirements section.

- 1 - Seal any unused openings in the common venting system.
- 2 - Inspect the venting system for proper size and horizontal pitch. Determine that there is no blockage, restriction, leakage, corrosion, or other deficiencies which could cause an unsafe condition.
- 3 - Close all building doors and windows and all doors between the space in which the appliances remaining connected to the common venting system are located

and other spaces of the building. Turn on clothes dryers and any appliances not connected to the common venting system. Turn on any exhaust fans, such as range hoods and bathroom exhausts, so they will operate at maximum speed. Do not operate a summer exhaust fan. Close fireplace dampers.

- 4 - Follow the lighting instructions. Turn on the appliance that is being inspected. Adjust the thermostat so that the appliance operates continuously.
- 5 - After the main burner has operated for five minutes, test for leaks of flue gases at the draft hood relief opening. Use the flame of a match or candle, or smoke from a cigarette, cigar, or pipe.
- 6 - After determining that each appliance connected to the common venting system is venting properly, (step 3) return all doors, windows, exhaust fans, fireplace dampers, and any other gas-burning appliances to their previous mode of operation.
- 7 - If a venting problem is found during any of the preceding tests, the common venting system must be modified to correct the problem.

Resize the common venting system to the minimum size determined by using the appropriate tables in appendix G. (These are in the current standards of the National Fuel Gas Code ANSI Z223.1 in the USA, and the appropriate Category 1 Natural Gas and Propane appliances venting sizing tables in the current standards of the CSA B149 Natural Gas and Propane Installation Codes in Canada.)

- 2 - When connecting the gas supply piping, consider factors such as length of run, number of fittings, and furnace rating to avoid excessive pressure drop. Table 9 lists recommended pipe sizes for typical applications.
- 3 - The gas piping must not run in or through air ducts, clothes chutes, gas vents or chimneys, dumb waiters, or elevator shafts.
- 4 - The piping should be sloped 1/4 inch (6.4 mm) per 15 feet (4.57 m) upward toward the meter from the furnace. The piping must be supported at proper intervals [every 8 to 10 feet (2.44 to 3.01 m)] with suitable hangers or straps. Install a drip leg inside vertical pipe runs to the unit.
- 5 - In some localities, codes may require the installation of a manual main shut-off valve and union (furnished by the installer) external to the unit. The union must be of the ground joint type.

Gas Piping

⚠ CAUTION

If a flexible gas connector is required or allowed by the authority that has jurisdiction, black iron pipe shall be installed at the gas valve and extend outside the furnace cabinet.

⚠ WARNING

Do not exceed 600 in-lbs (50 ft-lbs) torque when attaching the gas piping to the gas valve.

⚠ IMPORTANT

Compounds used on threaded joints of gas piping must be resistant to the actions of liquified petroleum gases.

NOTE - Install a 1/8 inch NPT plugged tap in the field piping upstream of the gas supply connection to the unit. The tap must be accessible for test gauge connection. See figure 19.

NOTE - If emergency shutoff is necessary, shut off the main manual gas valve and disconnect main power to the furnace. The installer should properly label these devices.

Gas Supply

- 1 - This unit is shipped standard for left or right side installation of gas piping (or top entry in horizontal applications). Connect the gas supply to the piping assembly.

TABLE 9
Gas Pipe Capacity - ft³/hr (m³/hr)

Nominal Iron Pipe Size inches (mm)	Internal Diameter inches (mm)	Length of Pipe - feet (m)									
		10 (3.048)	20 (6.096)	30 (9.144)	40 (12.192)	50 (15.240)	60 (18.288)	70 (21.336)	80 (24.384)	90 (27.432)	100 (30.480)
3/8 (9.53)	.493 (12.522)	95 (2.69)	65 (1.84)	52 (1.47)	45 (1.27)	40 (1.13)	36 (1.02)	33 (.73)	31 (.88)	29 (.82)	27 (.76)
1/2 (12.7)	.622 (17.799)	175 (4.96)	120 (3.40)	97 (2.75)	82 (2.32)	73 (2.07)	66 (1.87)	61 (1.73)	57 (1.61)	53 (1.50)	50 (1.42)
3/4 (19.05)	.824 (20.930)	360 (10.19)	250 (7.08)	200 (5.66)	170 (4.81)	151 (4.28)	138 (3.91)	125 (3.54)	118 (3.34)	110 (3.11)	103 (2.92)
1 (25.4)	1.049 (26.645)	680 (919.25)	465 (13.17)	375 (10.62)	320 (9.06)	285 (8.07)	260 (7.36)	240 (6.80)	220 (6.23)	205 (5.80)	195 (5.52)
1-1/4 (31.75)	1.380 (35.052)	1400 (39.64)	950 (26.90)	770 (21.80)	660 (18.69)	580 (16.42)	530 (15.01)	490 (13.87)	460 (13.03)	430 (12.18)	400 (11.33)
1-1/2 (38.1)	1.610 (40.894)	2100 (59.46)	460 (41.34)	1180 (33.41)	990 (28.03)	900 (25.48)	810 (22.94)	750 (21.24)	690 (19.54)	650 (18.41)	620 (17.56)
2 (50.8)	2.067 (52.502)	3950 (111.85)	2750 (77.87)	2200 (62.30)	1900 (53.80)	1680 (47.57)	1520 (43.04)	1400 (39.64)	1300 (36.81)	1220 (34.55)	1150 (32.56)
2-1/2 (63.5)	2.469 (67.713)	6300 (178.39)	4350 (123.17)	3520 (99.67)	3000 (84.95)	2650 (75.04)	2400 (67.96)	2250 (63.71)	2050 (58.05)	1950 (55.22)	1850 (52.38)
3 (76.2)	3.068 (77.927)	11000 (311.48)	7700 (218.03)	6250 (176.98)	5300 (150.07)	4750 (134.50)	4300 (121.76)	3900 (110.43)	3700 (104.77)	3450 (97.69)	3250 (92.03)

NOTE - Capacity given in cubic feet (m³) of gas per hour and based on 0.60 specific gravity gas.

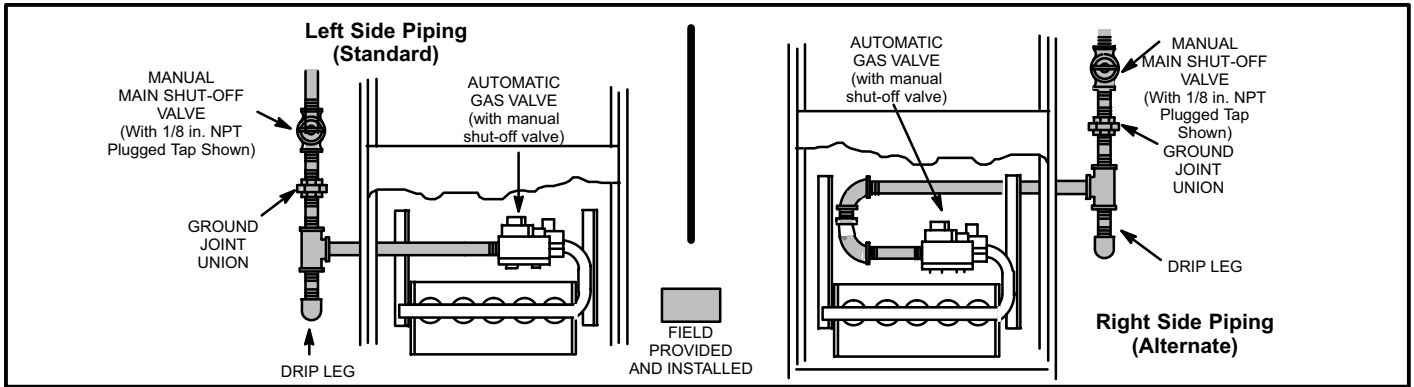

FIGURE 19

Leak Check

After gas piping is completed, carefully check all piping connections (factory- and field-installed) for gas leaks. Use a leak detecting solution or other preferred means.

NOTE - If emergency shutoff is necessary, shut off the main manual gas valve and disconnect the main power to the furnace. The installer should properly label these devices.

⚠ CAUTION

Some soaps used for leak detection are corrosive to certain metals. Carefully rinse piping thoroughly after leak test has been completed. Do not use matches, candles, flame or other sources of ignition to check for gas leaks.

The furnace must be isolated from the gas supply system by closing its individual manual shut-off valve during any pressure testing of the gas supply system at pressures less than or equal to 1/2 psig (3.48 kPa, 14 inches w.c.).

⚠ IMPORTANT

When testing pressure of gas lines, gas valve must be disconnected and isolated. See figure 20. Gas valves can be damaged if subjected to pressures greater than 1/2 psig (3.48 kPa, 14 inches w.c.).

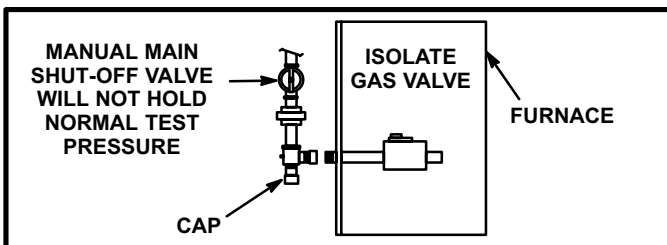

FIGURE 20

Electrical

**ELECTROSTATIC DISCHARGE (ESD)
Precautions and Procedures**

⚠ CAUTION

Electrostatic discharge can affect electronic components. Take precautions during furnace installation and service to protect the furnace's electronic controls. Precautions will help to avoid control exposure to electrostatic discharge by putting the furnace, the control and the technician at the same electrostatic potential. Neutralize electrostatic charge by touching hand and all tools on an unpainted unit surface, such as the gas valve or blower deck, before performing any service procedure.

The unit is equipped with a field make-up box. The make-up box may be moved to the right side of the furnace to facilitate installation. If the make-up box is moved to the right side, the excess wire must be pulled into the blower compartment. Secure the excess wire to the existing harness to protect it from damage.

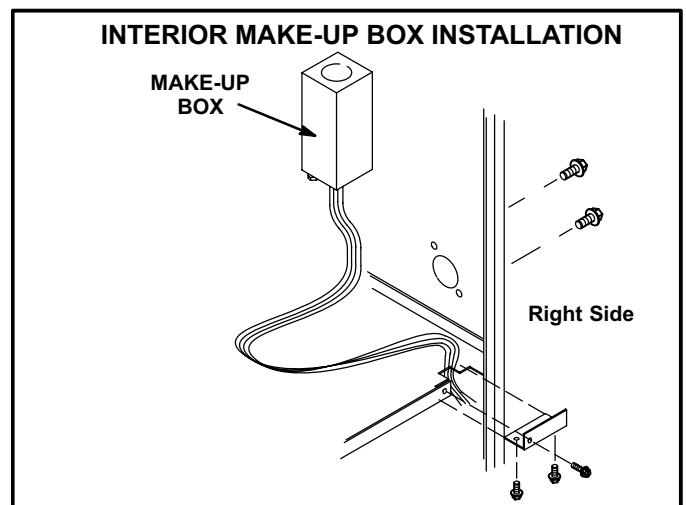

FIGURE 21

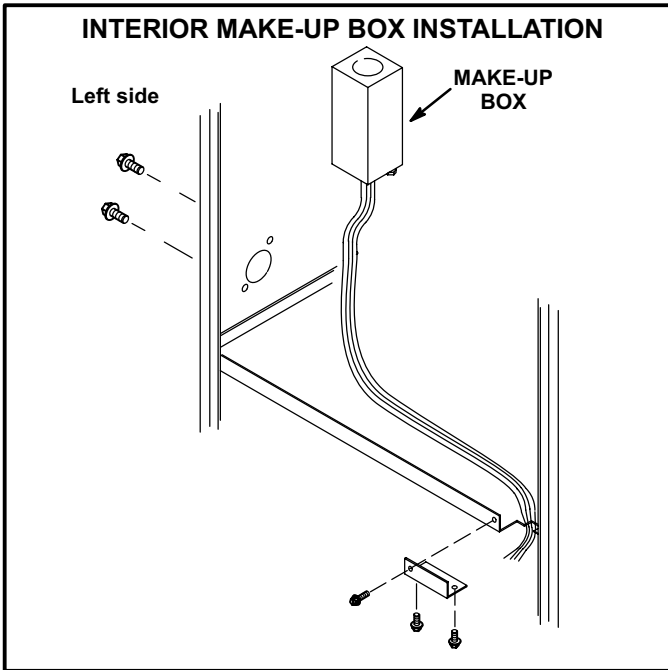

FIGURE 22

Refer to figure 24 for field wiring and figure 26 for schematic wiring diagram and troubleshooting.

- 1 - Select circuit protection and wire size according to the unit nameplate. The power supply wiring must meet Class I restrictions.
- 2 - Holes are on both sides of the furnace cabinet to facilitate wiring.
- 3 - Install a separate disconnect switch (protected by either fuse or circuit breaker) near the furnace so that power can be turned off for servicing.
- 4 - Before connecting the thermostat or the power wiring, check to make sure the wires will be long enough for servicing at a later date. Remove the blower access panel to check the length of the wire.
- 5 - Complete the wiring connections to the equipment. Use the provided unit wiring diagram and the field wiring diagram shown in figure 24. Use 18-gauge wire or larger that is suitable for Class II rating for thermostat connections.
- 6 - Electrically ground the unit according to local codes or, in the absence of local codes, according to the current National Electric Code (ANSI/NFPA No. 70) for the USA and current Canadian Electric Code part 1 (CSA standard C22.1) for Canada. A green ground wire is provided in the field make-up box.

NOTE - The G40UH(X) furnace contains electronic components that are polarity sensitive. Make sure that the furnace is wired correctly and is properly grounded.

- 7 - One line voltage “EAC” accessory terminal is provided on the furnace control board. Any electronic air cleaner rated up to one amp can be connected to this terminal with the neutral leg of the circuit being connected to the any of the “NEUTRAL” terminals. See figure 25 for control board configuration. This terminal is energized whenever the blower is operating.
- 8 - One line voltage “HUM” accessory terminal is provided on the furnace control board. Any humidifier rated up to one amp can be connected to this terminal with the neutral leg of the circuit being connected to any of the “NEUTRAL” terminals. See figure 25 for control board configuration. This terminal is energized in the heating mode whenever the combustion air inducer is operating.
- 9 - Install the room thermostat according to the instructions provided with the thermostat. See figure 23 for thermostat designations. If the furnace is being matched with a heat pump, refer to the FM21 installation instruction.

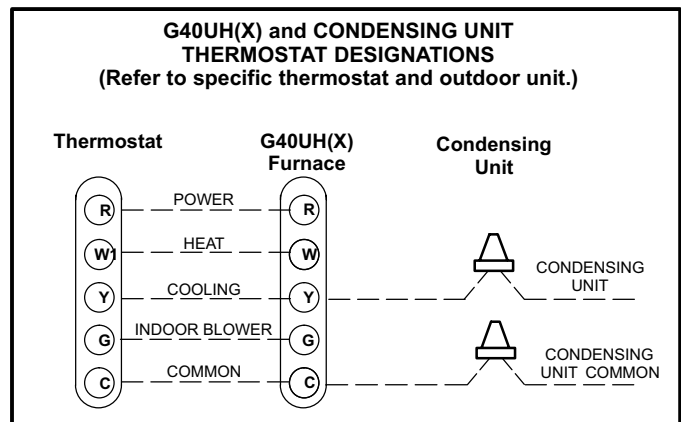

FIGURE 23

Indoor Blower Speeds

- 1 - When the thermostat is set to “FAN ON,” the indoor blower will run continuously on the heating speed when there is no cooling or heating demand.
- 2 - When the G40UH(X) is running in the heating mode, the indoor blower will run on the heating speed.
- 3 - When there is a cooling demand, the indoor blower will run on the cooling speed.

TYPICAL G40UH(X) FIELD WIRING DIAGRAM

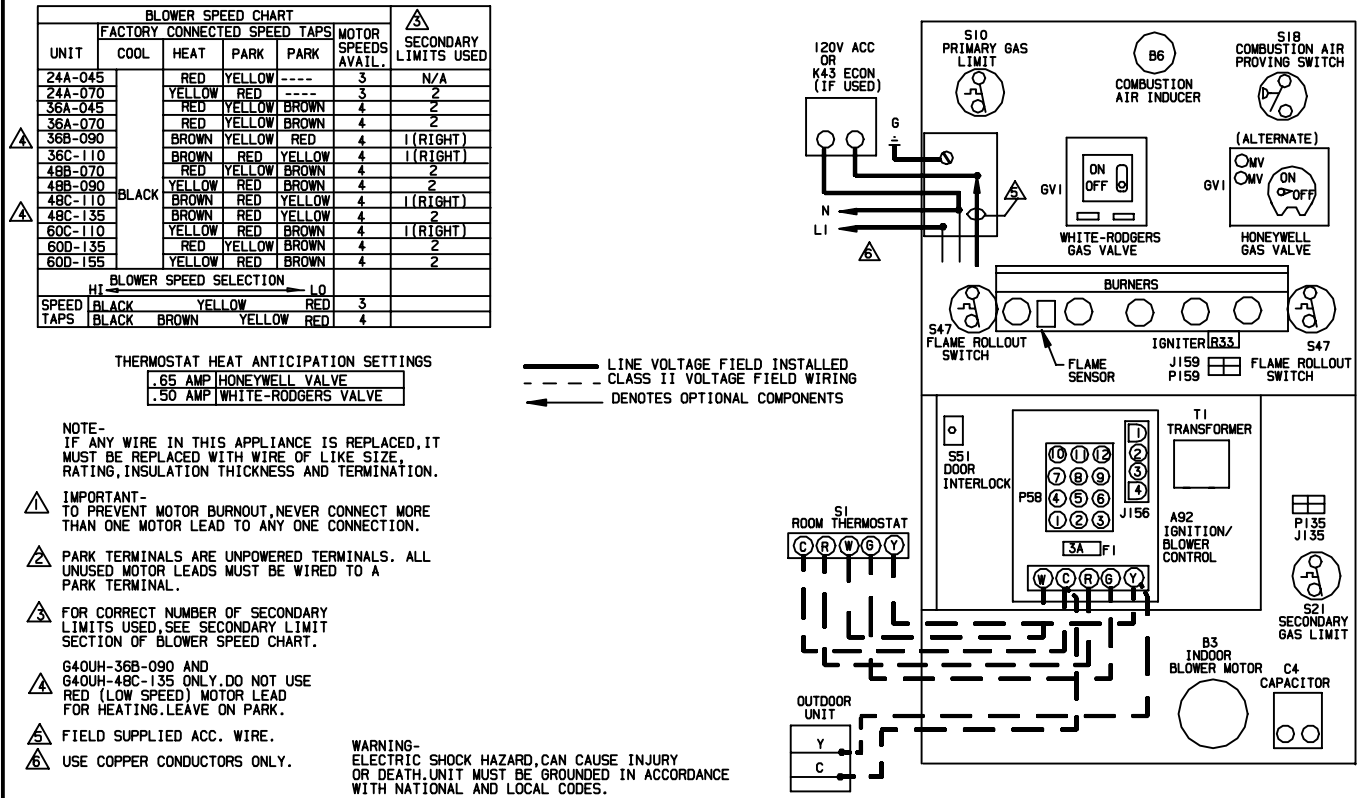
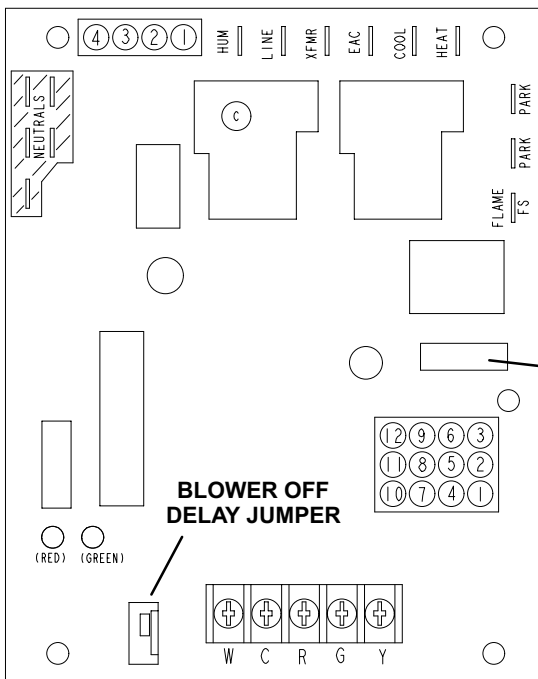

FIGURE 24

INTEGRATED CONTROL BOARD (Automatic Hot Surface Ignition System)



TERMINAL DESIGNATIONS	
HUM	Humidifier (120VAC)
LINE	Input (120VAC)
XFMR	Transformer (120VAC)
EAC	Electronic Air Cleaner (120VAC)
COOL	Blower - Cooling Speed (120VAC)
HEAT	Blower - Heating Speed (120VAC)
PARK	Dead terminals to park alternate spd taps
FLAME	Flame sensor
NEUTRALS	Neutral terminals (120VAC)

FIGURE 25

G40UH(X) Schematic Wiring Diagram

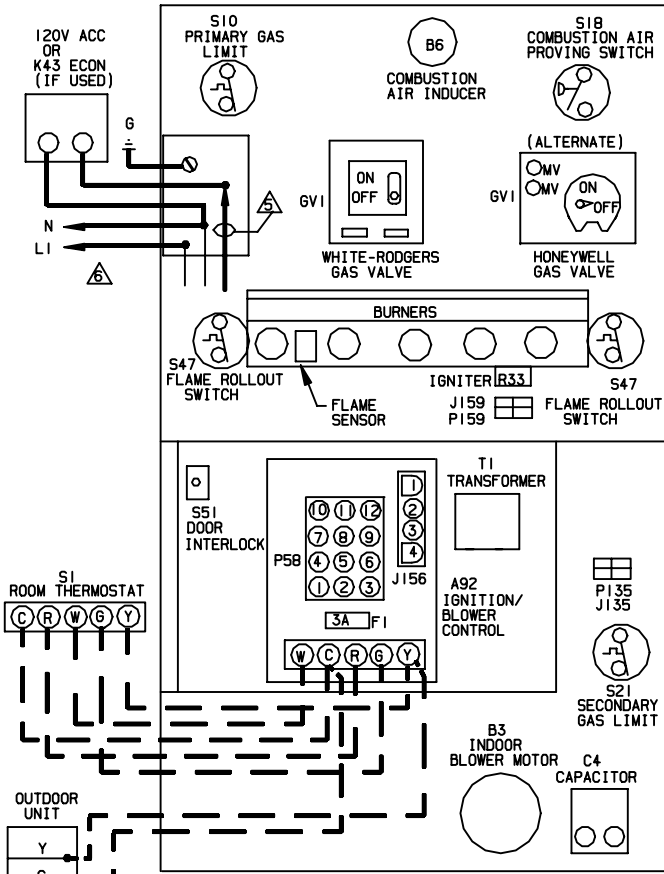

BLOWER SPEED CHART						SECONDARY LIMITS USED
UNIT	FACTORY CONNECTED SPEED TAPS			MOTOR SPEEDS AVAILABLE		
24A-045	RED	YELLOW	----	3	N/A	
24A-070	YELLOW	RED	----	3	2	
36A-045	RED	YELLOW	BROWN	4	2	
36A-070	RED	YELLOW	BROWN	4	2	
36B-090	BROWN	YELLOW	RED	4	1 (RIGHT)	
36C-110	BROWN	RED	YELLOW	4	1 (RIGHT)	
48B-070	RED	YELLOW	BROWN	4	2	
48B-090	YELLOW	RED	BROWN	4	2	
48C-110	BROWN	RED	YELLOW	4	1 (RIGHT)	
48C-135	BROWN	RED	YELLOW	4	2	
60C-110	YELLOW	RED	BROWN	4	1 (RIGHT)	
60D-135	RED	YELLOW	BROWN	4	2	
60D-155	YELLOW	RED	BROWN	4	2	

HT ← BLOWER SPEED SELECTION → LO

SPEED TAPS	BLACK	BROWN	YELLOW	RED	RED
	3				
	4				

THERMOSTAT HEAT ANTICIPATION SETTINGS
 .65 AMP HONEYWELL VALVE
 .50 AMP WHITE-RODGERS VALVE

JACKPLUG CHART	
J.P58	JACK/PLUG-BURNER CONTROL
J.P84	JACK/PLUG-COMB AIR INDUCER
J.P135	JACK/PLUG-SECONDARY LIMIT
J.P156	JACK/PLUG-INDUCER/IGNITER
J.P159	JACK/PLUG-IGNITION

NOTE-
 IF ANY WIRE IN THIS APPLIANCE IS REPLACED, IT MUST BE REPLACED WITH WIRE OF LIKE SIZE, RATING, INSULATION THICKNESS AND TERMINATION.

- ⚠ IMPORTANT- TO PREVENT MOTOR BURNOUT, NEVER CONNECT MORE THAN ONE MOTOR LEAD TO ANY ONE CONNECTION.
- ⚠ PARK TERMINALS ARE UNPOWERED TERMINALS. ALL UNUSED MOTOR LEADS MUST BE WIRED TO A PARK TERMINAL.
- ⚠ FOR CORRECT NUMBER OF SECONDARY LIMITS USED, SEE SECONDARY LIMIT SECTION OF BLOWER SPEED CHART.
- ⚠ G40UH-36B-090 AND G40UH-48C-135 ONLY, DO NOT USE RED (LOW SPEED) MOTOR LEAD FOR HEATING. LEAVE ON PARK.
- ⚠ FIELD SUPPLIED ACC. WIRE.
- ⚠ USE COPPER CONDUCTORS ONLY.

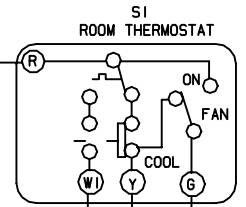

— LINE VOLTAGE FIELD INSTALLED
 - - - CLASS II VOLTAGE FIELD WIRING
 ← DENOTES OPTIONAL COMPONENTS

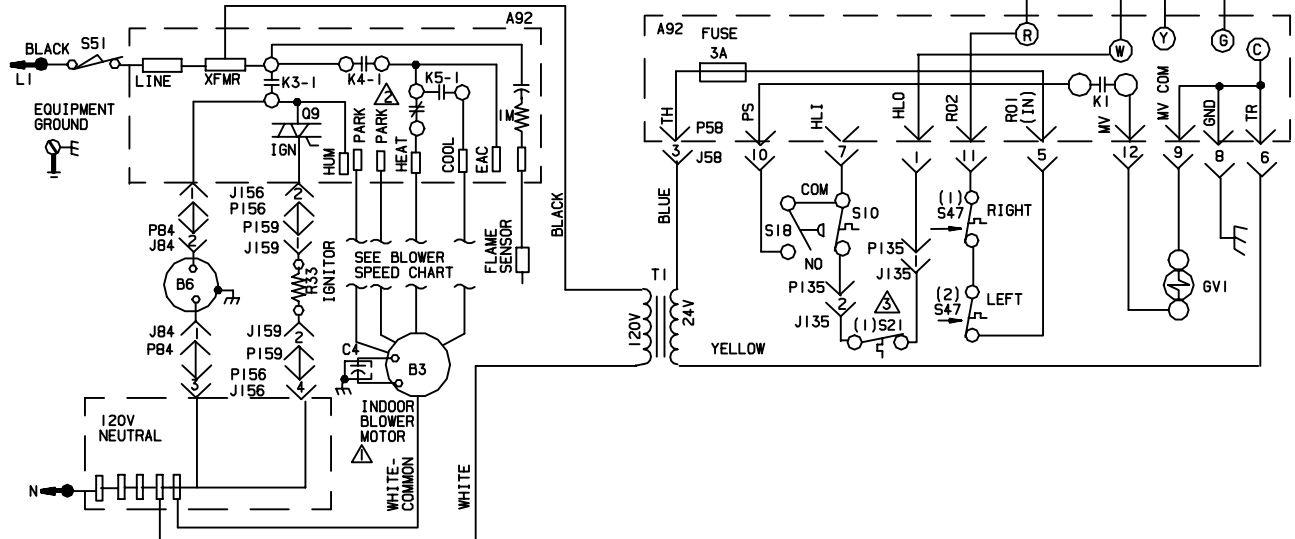

WARNING-
 ELECTRIC SHOCK HAZARD, CAN CAUSE INJURY OR DEATH. UNIT MUST BE GROUNDED IN ACCORDANCE WITH NATIONAL AND LOCAL CODES.

FIGURE 26

Unit Start-Up

FOR YOUR SAFETY READ BEFORE LIGHTING

⚠ WARNING

Do not use this furnace if any part has been underwater. Immediately call a qualified service technician to inspect the furnace and to replace any part of the control system and any gas control which has been under water.

⚠ WARNING

If overheating occurs or if gas supply fails to shut off, shut off the manual gas valve to the appliance before shutting off electrical supply.

⚠ CAUTION

Before attempting to perform any service or maintenance, turn the electrical power to unit OFF at disconnect switch.

BEFORE LIGHTING smell all around the appliance area for gas. Be sure to smell next to the floor because some gas is heavier than air and will settle on the floor.

The gas valve on the G40UH(X) unit may be equipped with either a gas control knob or gas control lever. Use only your hand to push the lever or to turn the gas control knob. Never use tools. If the knob will not turn or if the lever will not move by hand, do not try to repair it. Call a qualified service technician. Force or attempted repair may result in a fire or explosion.

Placing the furnace into operation:

G40UH(X) units are equipped with an automatic hot surface ignition system. Do not attempt to manually light burners on these furnaces. Each time the thermostat calls for heat, the burners will automatically light. The igniter does not get hot when there is no call for heat on units with this ignition system.

⚠ WARNING

If you do not follow these instructions exactly, a fire or explosion may result causing property damage, personal injury or death.

Gas Valve Operation (Figures 27, 28 and 29)

- 1 - **STOP!** Read the safety information at the beginning of this section.
- 2 - Set the thermostat to the lowest setting.

- 3 - Turn off all electrical power to the unit.
- 4 - This furnace is equipped with an ignition device which automatically lights the burners. Do **not** try to light the burners by hand.
- 5 - Remove the upper access panel.
- 6 - *Honeywell VR8205 Gas Valve with ON/OFF Switch* - Move gas valve switch to **OFF**. See figure 27.
Honeywell VR8205 Gas Valve with Control Knob - Turn knob on gas valve clockwise ➡ to **OFF**. Do not force. See figure 28.
White Rodgers 36G Gas Valve - Move gas valve switch to **OFF**. See figure 29.
- 7 - Wait five minutes to clear out any gas. If you then smell gas, **STOP!** Immediately call your gas supplier from a neighbor's phone. Follow the gas supplier's instructions. If you do not smell gas go to next step.

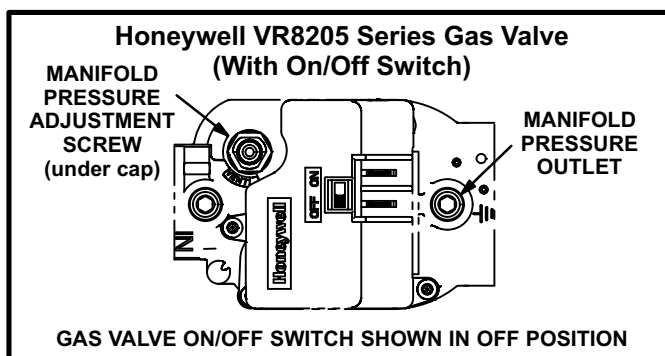

FIGURE 27

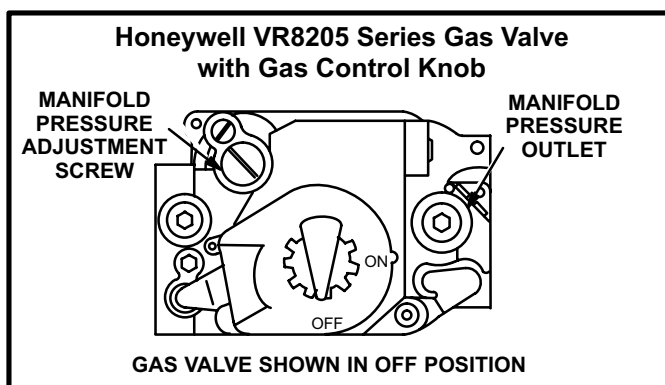

FIGURE 28

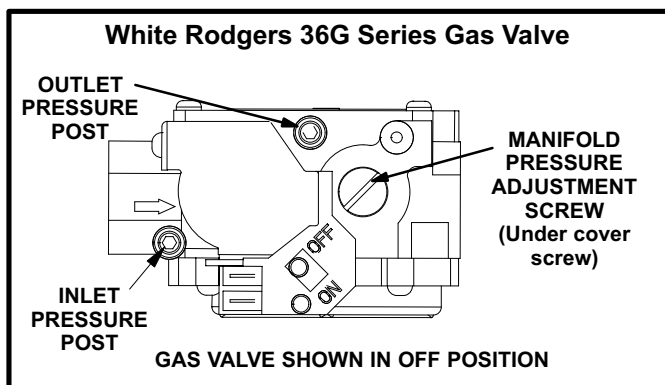



FIGURE 29

- 8 - *Honeywell VR8205 Gas Valve with ON/OFF Switch* - Move gas valve switch to **ON**. See figure 27.
Honeywell VR8205 Gas Valve with Control Knob - Turn knob on gas valve counterclockwise  to **ON**. Do not force. See figure 28.
White Rodgers 36G Gas Valve - Move gas valve switch to **ON**. See figure 29.

- 9 - Replace the upper access panel.
- 10- Turn on all electrical power to to the unit.
- 11- Set the thermostat to desired setting.

NOTE - When unit is initially started, steps 1 through 11 may need to be repeated to purge air from gas line.

- 12- If the appliance will not operate, follow the instructions "Turning Off Gas to Unit" and call your service technician or gas supplier.

Turning Off Gas to Unit

- 1 - Set the thermostat to the lowest setting.
- 2 - Turn off all electrical power to the unit if service is to be performed.
- 3 - Remove the upper access panel.
- 4 - *Honeywell VR8205 Gas Valve with ON/OFF Switch* - Move gas valve switch to **OFF**. See figure 27.
Honeywell VR8205 Gas Valve with Control Knob - Turn knob on gas valve clockwise  to **OFF**. Do not force. See figure 28.
White Rodgers 36G Gas Valve - Move gas valve switch to **OFF**. See figure 29.
- 5 - Replace the upper access panel.

Heating Sequence Of Operation

- 1 - When thermostat calls for heat, combustion air inducer starts.
- 2 - Combustion air pressure switch proves blower operation. Switch is factory set and requires no adjustment.
- 3 - After a 15-second prepurge, the hot surface igniter energizes.
- 4 - After a 20-second igniter warm-up period, the gas valve solenoid opens.
- 5 - Gas is ignited, flame sensor proves the flame, and the combustion process continues.
- 6 - If flame is not detected after first ignition trial, the ignition control will repeat steps 3 and 4 four more times before locking out the gas valve ("WATCHGUARD" flame failure mode). The ignition control will then automatically repeat steps 1 through 6 after 60 minutes.
- 7 - To interrupt the 60-minute "WATCHGUARD" period, move thermostat from "Heat" to "OFF" then back to "Heat". Heating sequence then restarts at step 1.

Gas Pressure Adjustment

Gas Flow (Approximate)

- 1 - Operate unit at least 15 minutes before checking gas flow. Determine the time in seconds for one revolutions of gas through the meter. A portable LP gas meter (17Y44) is available for LP applications.
- 2 - Compare the number of seconds and the gas meter size in table 10 to determine the gas flow rate. Multiply the gas flow rate by the heating value to determine the unit input rate. If manifold pressure is correct and the unit input rate is incorrect, check gas orifices for proper size and restriction.
- 3 - Remove temporary gas meter if installed.

NOTE - To obtain accurate reading, shut off all other gas appliances connected to meter.

TABLE 10

Gas Flow Rate (Ft. ³ /Hr.)		
Seconds for 1 Revolution	Gas Meter Size	
	1/2 cu ft Dial	1 cu ft Dial
10	180	360
12	150	300
14	129	257
16	113	225
18	100	200
20	90	180
22	82	164
24	75	150
26	69	138
28	64	129
30	60	120
32	56	113
34	53	106
36	50	100
38	47	95
40	45	90
42	43	86
44	41	82
46	39	78
48	38	75
50	36	72
52	35	69
54	33	67
56	32	64
58	31	62
60	30	60

! IMPORTANT

For safety, shut unit off and remove manometer as soon as an accurate reading has been obtained. Take care to replace pressure tap plug.

Gas Pressure

- 1 - Check the gas line pressure with the unit firing at maximum rate. A minimum of 4.5 in. w.c. for natural gas or 11.0 in. w.c. for LP/propane gas should be maintained.
- 2 - After the line pressure has been checked and adjusted, check the manifold pressure. A natural gas to LP/propane gas changeover kit is required to convert the unit. Manifold pressure for all units is given in table 11. See figures 27, 28 and 29 for the location of the manifold pressure adjustment screws.

High Altitude Information

NOTE - In Canada, certification for installations at elevations over 4500 feet (1372 m) is the jurisdiction of local authorities.

The manifold pressure may require adjustment to ensure proper operation at higher altitudes. See table 11 for proper manifold pressure settings at varying altitudes.

TABLE 11
Manifold Pressure (Outlet) inches w.c.

Fuel	Altitude (feet)			
	0-4500	4501-5500	5501-6500	6501-7500
Nat. Gas	3.5	3.3	3.2	3.1
L.P. Gas	10.0	10.0	10.0	10.0

NOTE - A natural to L.P. propane gas changeover kit is necessary to convert this unit. L.P. conversion kit 45L60 is used with all units installed at altitudes up to 7,500 feet. L.P. conversion kit 47M81 is used with all units installed at altitudes from 7,501 to 10,000 feet above sea level. Refer to the changeover kit installation instruction for the conversion procedure.

NOTE - Units fueled by natural gas and installed at altitudes of 7501-10,000 feet above sea level require installation of a high altitude orifice kit (47M82).

The combustion air pressure switches are factory-set and require no adjustment. Table 12 lists the replacement pressure switch required for G40UH(X) units installed at altitudes above 4,500 feet above sea level.

TABLE 12

Model	Altitude (feet)	
	4501-7500 Pres. Switch Replacement Required	7501-10000 Pres. Switch Replacement Required
G40UH(X)-045-070	56L32	56L32
G40UH(X)-090-110	49L90	15M22
G40UH(X)-135-155	49L90	15M22

Other Unit Adjustments

Primary and Secondary Limits

The primary limit is located on the heating compartment vestibule panel. The secondary limits (if equipped) are located in the blower compartment, attached to the back side of the blower. These limits are factory set and require no adjustment.

Flame Rollout Switches (Two)

These manually reset switches are located on (or inside of) the burner box. If tripped, check for adequate combustion air before resetting.

Pressure Switch

The pressure switch is located in the heating compartment adjacent to the combustion air inducer. This switch checks for proper combustion air inducer operation before allowing ignition trial. The switch is factory-set and requires no adjustment.

Temperature Rise

Place the unit into operation with a heating demand. After supply and return air temperatures have stabilized, check the temperature rise. If necessary, adjust the blower speed to maintain the temperature rise within the range shown on the unit nameplate. Increase the blower speed to decrease the temperature rise. Decrease the blower speed to increase the temperature rise. Failure to adjust the temperature rise may cause erratic limit operation.

Fan Control

There is no cooling mode fan on delay; however, there is a cooling fan off delay of 45 seconds. This delay is not adjustable.

The heating mode fan on delay of 45 seconds is not adjustable. The heating mode fan off delay (amount of time that the blower operates after the heat demand has been satisfied) may be adjusted by changing the jumper position across the five pins on the integrated control. The unit is shipped with a factory fan off setting of 90 seconds. The fan off delay affects comfort and is adjustable to satisfy individual applications. Adjust the fan off delay to achieve a supply air temperature between 90° and 110°F at the exact moment that the blower is de-energized. Longer off delay settings provide lower return air temperatures; shorter settings provide higher return air temperatures. See figure 30.

FAN-OFF TIME ADJUSTMENT

JUMPER POSITION		HEAT OFF DELAY
OFF	OFF	180
PIN1	PIN2	60
PIN2	PIN3	90
PIN3	PIN4	120
PIN4	PIN5	180

To adjust fan-off timing, reposition jumper across pins to achieve desired setting.

FIGURE 30

Thermostat Heat Anticipation

Set the heat anticipator setting (if adjustable) according to the amp draw listed on the wiring diagram that is attached to the unit.

Electrical

- 1 - Check all wiring for loose connections.
- 2 - Check for the correct voltage at the furnace (furnace operating).
- 3 - Check amp-draw on the blower motor.
Motor Nameplate _____ Actual _____

NOTE - Do not secure the electrical conduit directly to the air ducts or structure.

Blower Speeds

NOTE - CFM readings are taken external to unit with a dry evaporator coil and without accessories.

- 1 - Turn off electrical power to furnace.
- 2 - Remove blower access panel.
- 3 - Disconnect existing speed tap at control board speed terminal.

NOTE - Termination of any unused motor leads must be insulated.

- 4 - Refer to blower speed selection chart on unit wiring diagram for desired heating or cooling speed.
- 5 - Connect selected speed tap at control board speed terminal.
- 6 - Resecure blower access panel.
- 7 - Turn on electrical power to furnace.

Electronic Ignition

The integrated ignition control has an added feature of an internal Watchguard control. The feature serves as an automatic reset device for ignition control lockout because the burner has failed to ignite. This type of lockout is usually due to low gas line pressure. After one hour of continuous thermostat demand for heat, the Watchguard will break and re-make thermostat demand to the furnace and automatically reset the control to begin the ignition sequence.

Flue And Chimney

- 1 - Check flue pipe, chimney and all connections for tightness and to make sure there is no blockage.
- 2 - Check unit for proper draft.
- 3 - Is pressure switch closed? Obstructed flue will cause unit to shut off at pressure switch. Check flue and outlet for blockages.
- 4 - Reset manual flame rollout switches on burner box cover.

Failure To Operate

If the unit fails to operate, check the following:

- 1 - Is the thermostat calling for heat?
- 2 - Are access panels securely in place?
- 3 - Is the main disconnect switch closed?
- 4 - Is there a blown fuse?

- 5 - Is the filter dirty or plugged? Dirty or plugged filters will cause the limit control to shut the unit off.
- 6 - Is gas turned on at the meter?
- 7 - Is the manual main shut-off valve open?
- 8 - Is the internal manual shut-off valve open?
- 9 - Is the unit ignition system in lock out? If the unit locks out again, call the service technician to inspect the unit for blockages.

Service

⚠ WARNING

Disconnect power before servicing unit.

⚠ CAUTION

Label all wires prior to disconnection when servicing controls. Wiring errors can cause improper and dangerous operation. Verify proper operation after servicing.

At the beginning of each heating season, a qualified technician should check the system as follows:

Blower

Check the blower wheel for debris and clean if necessary. The blower motors are prelubricated for extended bearing life. No further lubrication is needed.

⚠ WARNING

The blower access panel must be securely in place when the blower and burners are operating. Gas fumes, which could contain carbon monoxide, can be drawn into living space resulting in personal injury or death.

Filters

All G40UH(X) filters are installed external to the unit. Filters should be inspected monthly. Clean or replace the filters when necessary to ensure proper furnace operation. Replacement filters must be rated for high velocity airflow. Table 1 lists recommended filter sizes.

Flue And Chimney

Check the flue pipe, chimney and all connections for tightness and to make sure there is no blockage.

Electrical

- 1 - Check all wiring for loose connections.
- 2 - Check for the correct voltage at the furnace (furnace operating).
- 3 - Check amp-draw on the blower motor.
Motor Nameplate _____ Actual _____

Cleaning the Heat Exchanger and Burners

NOTE - Use papers or protective covering in front of the furnace while you clean furnace.

Cleaning the heat exchanger requires a steel spring "snake," a reversible drill and a vacuum cleaner. The steel spring snake may be constructed by purchasing a 4 ft. long by 1/4 inch diameter steel wire cable and a 1/4 inch diameter wire brush. These items are available at a hardware store. Insert wire end of brush into the open end of the spring cable. Crimp the cable around the brush so that the brush is secured and will not come off during cleaning. Attach the other end of the cable to the reversible drill to complete the tool for cleaning the heat exchanger.

- 1 - Turn off both electrical and gas power supplies to furnace.
- 2 - Remove flue pipe and top cap from the unit. Label the pressure switch wires, then disconnect them.
- 3 - Remove the four screws that secure the combustion air inducer. Carefully remove the combustion air inducer to avoid damaging blower gasket. If gasket is damaged, it must be replaced to prevent leakage. See figure 31.

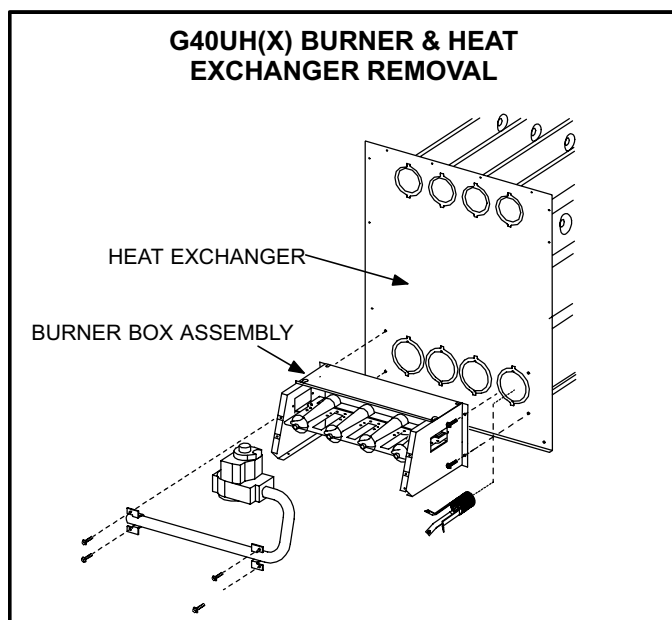

FIGURE 31

- 4 - Remove the collector box located behind the combustion air inducer. Be careful with the collector box gasket. If the gasket is damaged you must replace it to prevent leakage.
- 5 - Label the wires from gas valve and rollout switches, then disconnect them.
- 6 - Disconnect gas supply piping. Remove four screws securing the burner manifold assembly to the vestibule panel and remove the assembly from the unit.

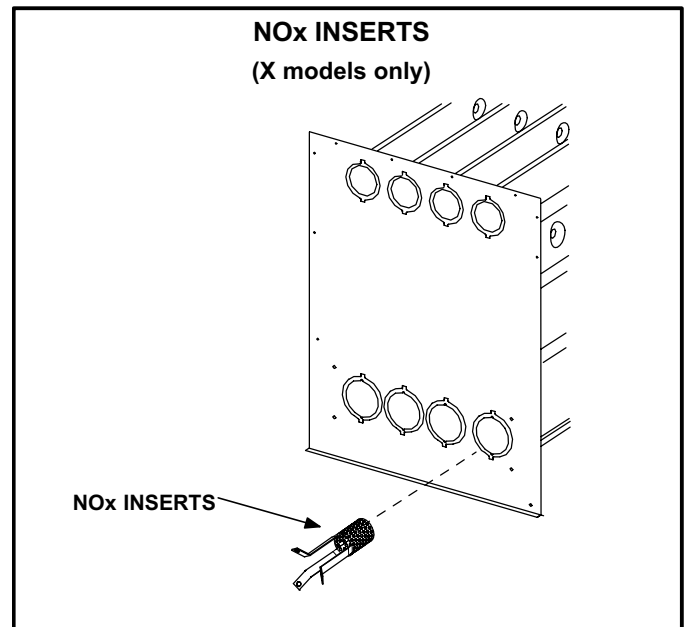

FIGURE 32

- 7 - **NOx units only** - remove the three screws that attach the NOx insert to the corbel at the entrance to each heat exchanger section. Carefully remove the NOx insert from each section. See figure 32.
- 8 - Insert the brush end of cable snake into the top of one of the heat exchanger openings. **Do not force the cable into the heat exchanger.** Insert the cable and operate the drill on slow speed. Move the cable in and out of the heat exchanger section three or four times or until sufficient cleaning is accomplished. Reverse drill and slowly work the cable out of opening.
- 9 - Repeat procedure for each heat exchanger section.
- 10 - After each of the top heat exchanger sections has been cleaned, insert the brush end of the cable snake into the bottom openings of each of the heat exchanger sections. Clean the bottom opening as described in step 8.
- 11 - Remove cable from heat exchanger. Use a vacuum cleaner to remove debris knocked loose during cleaning from each heat exchanger section.
- 12 - Attach the exhaust end (positive pressure) of the vacuum cleaner to the top of the heat exchanger section. Any loose debris will be forced to the bottom of the heat exchanger section. Vacuum debris from bottom openings.
- 13 - Replace collector box and combustion air inducer. Check gaskets for damage. Damaged gaskets must be replaced to avoid heat exchanger leaks. Replace all screws to the collector box and combustion air inducer. Failure to replace all screws may cause leaks.

- 14- To clean the burner, run a vacuum cleaner with a soft brush attachment over the face of burners. Visually inspect inside the burners and crossovers for any blockage caused by foreign matter. Remove any blockage.
- 15- **NOx Units** - Reattach the NOx inserts to the corbels at the entrance to each heat exchanger opening. See figure 32.
- 16- Replace burner/manifold assembly onto the vestibule panel.
- 17- Reconnect wires to pressure switch, roll-out switches, gas valve and combustion air inducer. Refer to unit wiring diagram.
- 18- Reconnect vent pipe to combustion air inducer outlet.
- 19- Reconnect gas supply piping.
- 20- Turn on power and gas supply to unit.

- 21- Set thermostat and check for proper operation.
- 22- Check all piping connections, factory and field, for gas leaks. Use a leak detecting solution or other preferred means.

⚠ CAUTION

Some soaps used for leak detection are corrosive to certain metals. Carefully rinse piping thoroughly after leak test has been completed. Do not use matches, candles, flame or other sources of ignition to check for gas leaks.

- 23- If a leak is detected, shut gas and electricity off and repair leak.
- 24- Repeat steps 23 and 24 until no leaks are detected.
- 25- Replace front access panel.

Repair Parts List

The following repair parts are available through Lennox dealers. When ordering parts, include the complete furnace model number listed on the CSA nameplate -- Example: G40UH(X)-24A-045-1.

Cabinet Parts

- Upper access panel
- Blower panel
- Top cap

Control Panel Parts

- Transformer
- Integrated ignition control board
- Door interlock switch
- Circuit breaker

Blower Parts

- Blower wheel
- Motor
- Motor mounting frame
- Motor capacitor
- Blower housing cutoff plate

Heating Parts

- Flame sensor
- Heat exchanger assembly
- Gas manifold
- Combustion air inducer
- Gas valve
- Main burner cluster
- Main burner orifices
- Pressure switch
- Igniter
- Primary limit control
- Flame rollout switch
- Secondary limit (not used on 24A-45-1)

Ignition Control Board Diagnostic Codes

DIAGNOSTIC CODES		
Make sure to Identify LED'S Correctly. Refer to figure NO TAG for control board layout.		
LED #1 (Red)	LED #2 (Green)	DESCRIPTION
SIMULTANEOUS SLOW FLASH	SIMULTANEOUS SLOW FLASH	Power on - Normal operation. Also signaled during cooling and continuous fan.
SIMULTANEOUS FAST FLASH	SIMULTANEOUS FAST FLASH	Normal operation - signaled when heating demand initiated at thermostat.
SLOW FLASH	ON	Primary or secondary limit switch open. Limit must close within 3 minutes or unit goes into 1 hour Watchguard.
OFF	SLOW FLASH	Pressure prove switch open. OR: Blocked inlet/exhaust vent; OR: Pressure switch closed prior to activation of combustion air inducer.
ALTERNATING SLOW FLASH	ALTERNATING SLOW FLASH	Watchguard -- burners failed to ignite or lost flame 5 times during single heating demand.
SLOW FLASH	OFF	Flame sensed without gas valve energized.
ON	SLOW FLASH	Rollout switch open. OR: 12-pin connector improperly attached.
ON	ON	Circuit board failure or control wired incorrectly.
ON	OFF	
OFF	ON	
FAST FLASH	SLOW FLASH	Main power polarity reversed. Switch line and neutral.
SLOW FLASH	FAST FLASH	Low flame signal. Measures below 1.5 microamps. Replace flame sense rod.
ALTERNATING FAST FLASH	ALTERNATING FAST FLASH	Improper main ground. OR: Line voltage below 90 volts.

NOTE - Slow flash rate equals 1 Hz (one flash per second). Fast flash rate equals 3 Hz (three flashes per second). Minimum flame sense current = 0.5 microAmps.

Troubleshooting

HEATING SEQUENCE OF OPERATION

NORMAL HEATING MODE

ABNORMAL HEATING MODE

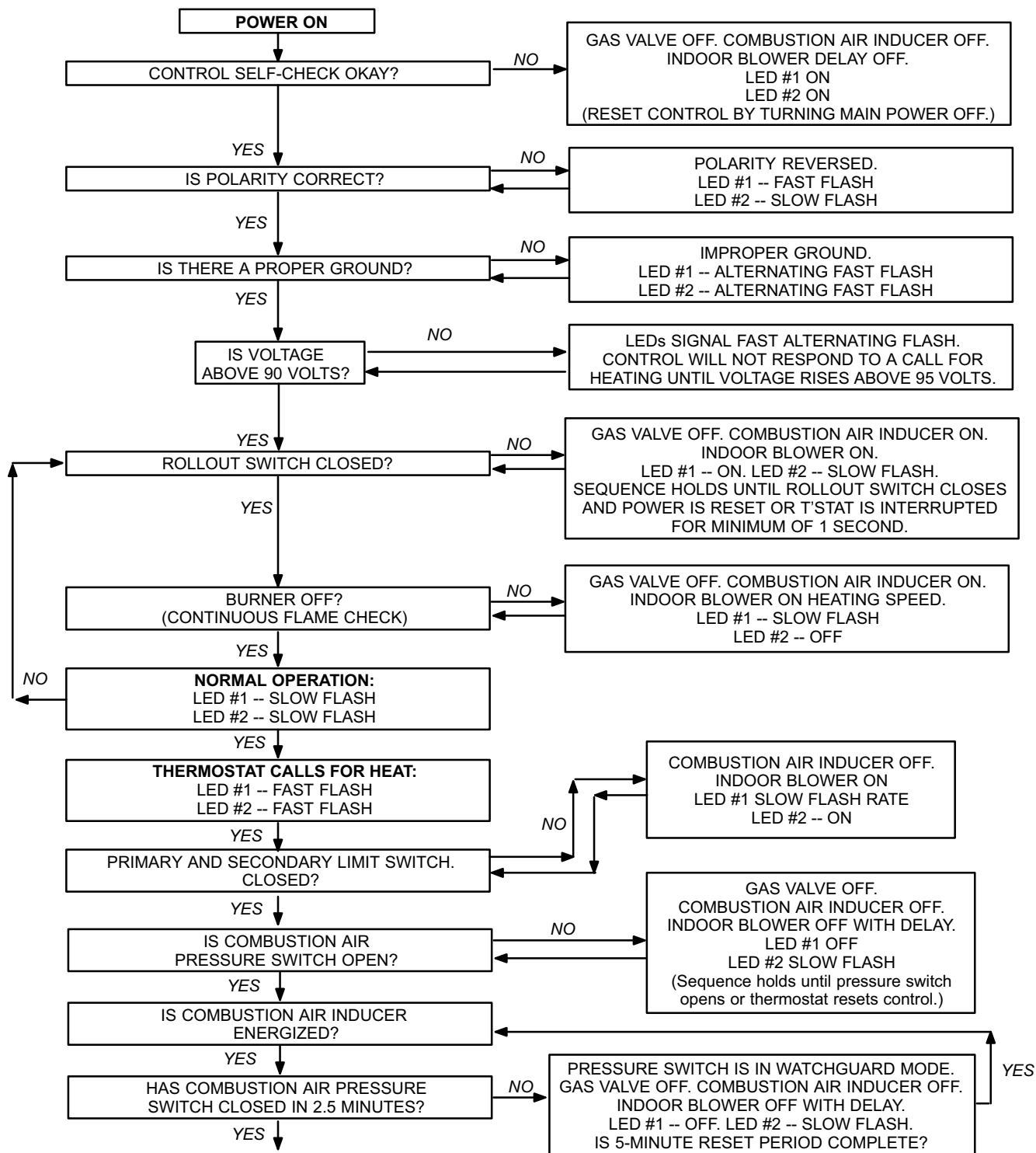

CONTINUED NEXT PAGE

Troubleshooting

HEATING SEQUENCE CONTINUED

NORMAL HEATING MODE

ABNORMAL HEATING MODE

15-SECOND COMBUSTION AIR INDUCER PREPURGE INITIATED BY CLOSED PRESSURE SWITCH.

YES

IGNITER WARM-UP -- 20 SECONDS.

YES

4-SECOND TRIAL FOR IGNITION. GAS VALVE OPENS. IGNITER ENERGIZED FOR UP TO 4 SECONDS.

YES

FLAME STABILIZATION PERIOD.

4 SECONDS

FLAME RECTIFICATION CURRENT CHECK. CAN FLAME BE PROVEN WITHIN 4 SECONDS AFTER GAS VALVE OPENS? (0.5 microamps)

YES

FLAME PRESENT?

YES

FLAME SIGNAL 1.5 MICROAMPS OR GREATER?

YES

INDOOR BLOWER ON AFTER 45-SECOND DELAY

YES

PRIMARY AND SECONDARY LIMIT SWITCHES CLOSED?

YES

ROLLOUT SWITCH CLOSED?

YES

COMBUSTION AIR PRESSURE SWITCH CLOSED?

YES

THERMOSTAT DEMAND SATISFIED.

YES

LED #1 & #2 SIMULTANEOUS SLOW FLASHES.

YES

COMB. AIR INDUCER CONTINUES 5-SECOND POST PURGE AFTER T'STAT DEMAND IS SATISFIED. INDOOR AIR BLOWER COMPLETES SELECTED "OFF" DELAY BEFORE SHUTTING OFF.

NO

IS VOLTAGE ABOVE 90 VOLTS?

YES

NO

LEDs SIGNAL ALTERNATING FAST FLASH UNTIL VOLTAGE IS ABOVE 95 VOLTS, THEN RESTARTS HEATING SEQUENCE.

NO

GAS VALVE OFF. COMBUSTION AIR INDUCER ON. INDOOR BLOWER OFF. HAS CONTROL FAILED TO SENSE FLAME FOR FIVE CONSECUTIVE TRIES DURING A SINGLE HEAT DEMAND?

NO

NO

WATCHGUARD MODE. GAS VALVE OFF. COMBUSTION AIR INDUCER OFF. INDOOR BLOWER OFF WITH DELAY. LEDS SIGNAL WATCHGUARD FAILURE CODE. IS 60-MINUTE RESET PERIOD COMPLETE?

YES

YES

NO

HAS CONTROL RESET IGNITION SEQUENCE FOUR TIMES?

NO

YES

NO

LOW FLAME SIGNAL (Does not affect operation of control) LED #1 -- SLOW FLASH LED #2 -- FAST FLASH

LIMIT SWITCH WATCHGUARD MODE. GAS VALVE, COMB. AIR INDUCER AND INDOOR BLOWER OFF. LEDS SIGNAL LIMIT SWITCH OPEN UNTIL MAIN POWER IS INTERRUPTED OR T'STAT IS CYCLED OFF/ON FOR 1 SEC. MINIMUM. 60-MINUTE WATCHGUARD PERIOD STARTS AT TIME LIMIT CLOSURE. IS 60-MIN. PERIOD COMPLETE?

NO

GAS VALVE DE-ENERGIZED. COMBUSTION AIR INDUCER DE-ENERGIZED. INDOOR BLOWER ON UNTIL SWITCH CLOSURE. LED #1 -- SLOW FLASH. LED #2 -- ON. IS LIMIT SWITCH CLOSED?

YES

NO

HAS PRIMARY / SECONDARY LIMIT RESET TIME EXCEEDED 3 MINUTES?

YES

NO

NO

GAS VALVE POWER OFF. COMBUSTION AIR INDUCER POWER ON. INDOOR BLOWER ON. LED #1 -- ON. LED #2 -- SLOW FLASH. SEQUENCE HOLDS UNTIL ROLLOUT SWITCH IS RESET AND MAIN POWER IS INTERRUPTED OR THERMOSTAT IS CYCLED OFF/ON FOR 1 SEC. MINIMUM.

NO

GAS VALVE DE-ENERGIZED. COMBUSTION AIR INDUCER ON. INDOOR BLOWER OFF WITH DELAY. LED #1 -- OFF. LED #2 -- SLOW FLASH. HAS CAB SWITCH CLOSED IN 2.5 MINUTES?

YES

NO

5-MINUTE PRESSURE SWITCH WATCHGUARD MODE.

Troubleshooting

COOLING SEQUENCE OF OPERATION

NORMAL COOLING MODE

ABNORMAL COOLING MODE

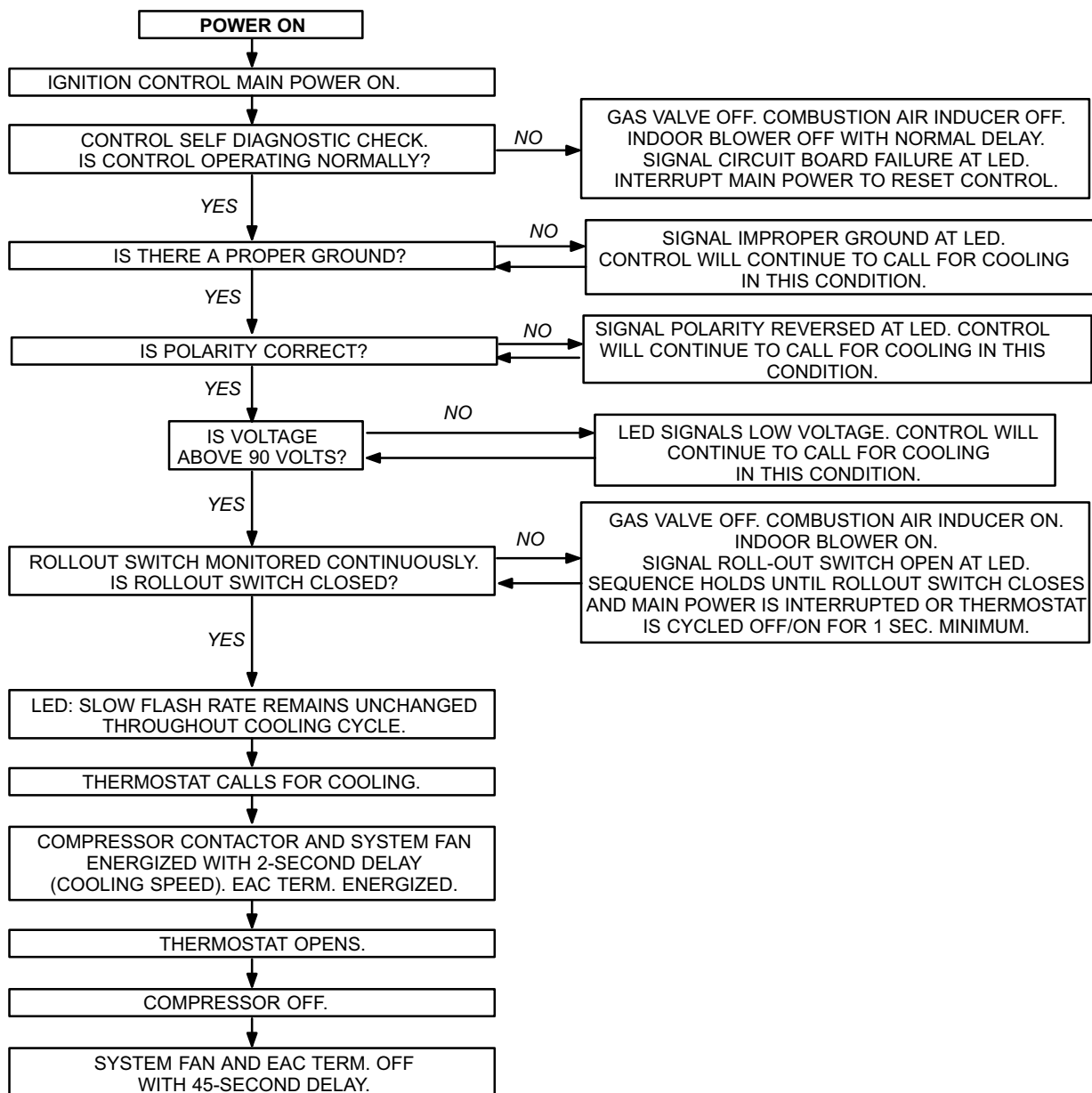

Troubleshooting

CONTINUOUS HEAT SPEED FAN SEQUENCE OF OPERATION

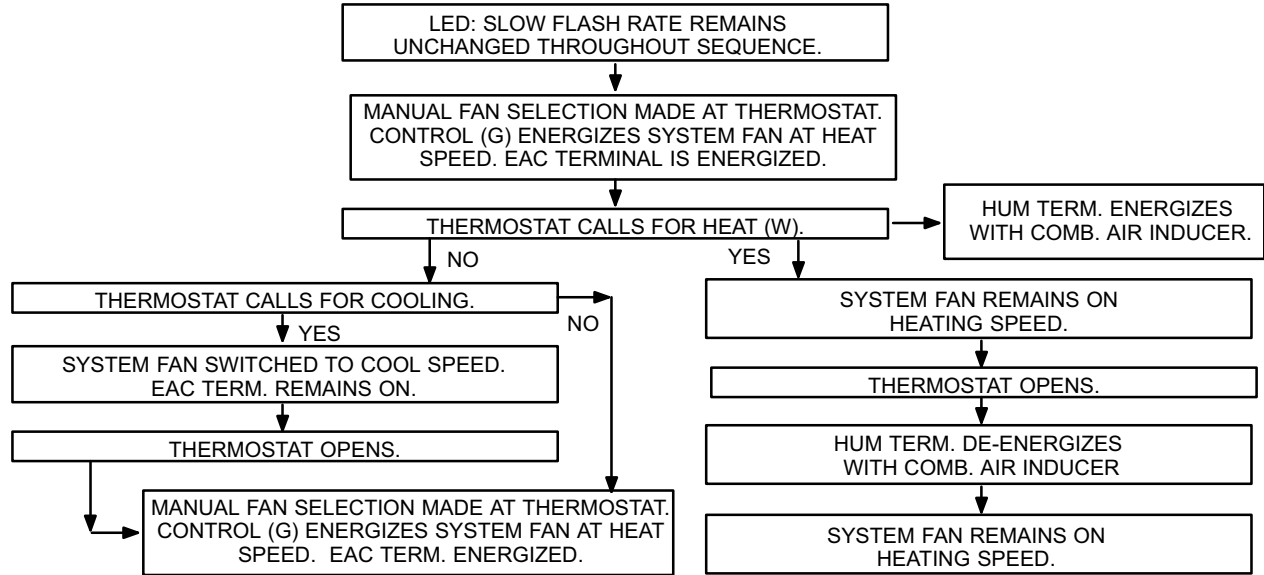

G40UH(X) Start-Up & Performance Check List

Job Name _____	Job No. _____	Date _____
Job Location _____	City _____	State _____
Installer _____	City _____	State _____
Unit Model No. _____	Technician _____	
Serial No. _____		
Heating Section		
Electrical Connections Tight? <input type="checkbox"/>	Supply Voltage _____	Blower Motor H.P. _____
Blower Motor Amps _____	Gas Piping Connections Tight & Leak-Tested? <input type="checkbox"/>	
Fuel Type: Natural Gas? <input type="checkbox"/>	LP/Propane Gas? <input type="checkbox"/>	
Furnace Btu Input _____	Line Pressure _____	
Regulator Pressure _____ w.c. - Nat.:	_____ w.c. - LP/Propane	
Flue Connections Tight? <input type="checkbox"/>	Proper Draft? <input type="checkbox"/>	
Combustion Gas Tested? CO ₂ <input type="checkbox"/>	CO <input type="checkbox"/>	
Fan Control Setting (45 Seconds Fixed On) _____	Temperature Rise _____	
Fan Control Off Setting _____		
Filter Clean & Secure? <input type="checkbox"/>	Vent Clear? <input type="checkbox"/>	
Thermostat		
Calibrated? <input type="checkbox"/>	Heat Anticipator Properly Set? <input type="checkbox"/>	Level? <input type="checkbox"/>