

This Owner's Manual is provided and hosted by [Appliance Factory Parts](#).



# Tradewinds TS571 Owner's Manual

[Shop genuine replacement parts for Tradewinds TS571](#)



[Find Your Tradewinds Evaporative Cooler Parts - Select From 4 Models](#)

----- Manual continues below -----



# FradeWinds

## EVAPORATIVE COOLERS

The Preferred Non-Metallic Evaporative Cooler  
5800 Murray St., Little Rock, AR 72209 USA

Owner's Manual  
TC451, TS451  
TC571, TS571

- Assembly
- Operation
- Repair Parts
- Maintenance

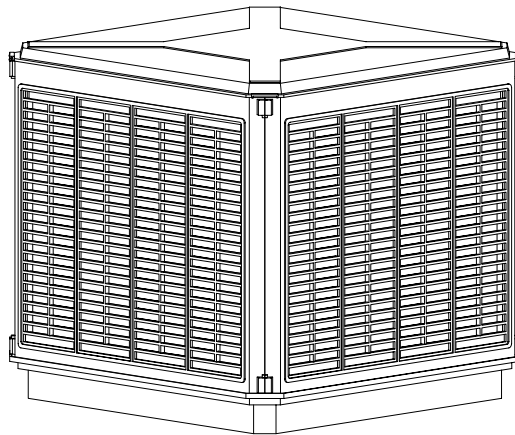

Down Discharge  
Models:  
TC451 & TC571

### READ AND SAVE THESE INSTRUCTIONS

**WARNING:** Install only per instructions. Failure to follow installation instructions may create a safety hazard and WILL void the warranty

**ALWAYS** disconnect the power from any evaporative cooler before attempting any kind of maintenance.

4 Major areas to check for proper operation

- Ensure unit is level
- Check for proper belt tension
- Check that water flows throughout the system
- Be sure that motor and blower pulleys are aligned

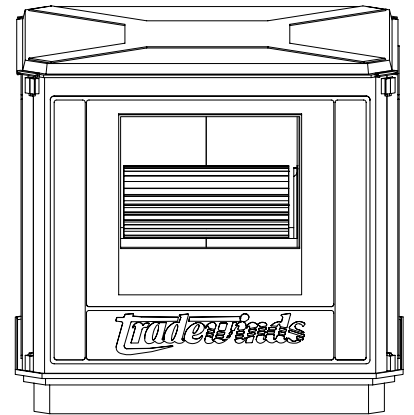

Side Discharge  
Models:  
TS451 & TS571

**Cooler MUST be installed on the legs provided**  
(Down discharge models only)

p/n 60OM  
rev. 3/02

## Your Evaporative cooler

Evaporative cooling uses the principle of evaporation to lower the air temperature. Hot, dry air is passed through wetted filters and is converted to refreshingly cooled air. Tradewinds coolers make the best use of the evaporative process by controlling the flow of water, spreading the water evenly over the filters, and keeping a steady stream of cooled air entering your home. It is exhausted out open windows or doors, carrying heat, smoke and odors along with it. Tradewinds evaporative coolers are 80% less costly to operate than refrigerated air conditioners.

**IMPORTANT: Do not attempt to install this cooler before reading all of the installation instructions and safety precautions.**

### Safety precautions

1. All duct work, installation work and electrical wiring must be done by qualified personnel in accordance with all applicable codes and standards, including fire-rated construction.
2. When cutting or drilling into walls or ceilings, extra precaution should be taken not to damage electrical wiring and other hidden utilities.
3. **Never** place a switch where it can be reached from a tub or a shower.
4. When transporting the unit up to a roof for installation, disassemble into parts: top, bottom, blower and louvers. Ensure that the installer has proper means to transport the unit to the roof. Cooler parts **may break** if dropped.
5. If the cooler will discharge into a room, install a grill over the discharge. The largest opening in such a grill must be smaller than one (1) inch.
6. Use this unit only in the manner intended by the manufacturer.
7. Always disconnect power to the unit at the circuit breaker and take steps to ensure power is **not** reconnected without your knowledge before attempting any kind of maintenance on the unit.
8. Always take precautions to ensure that you are safe when working on a roof.
9. Do not attempt to service the cooler unless you have the proper tools, and you know how to use them properly.

### Installation

Your downdraft Tradewinds cooler must be installed on a FLANGED ROOF JACK in order to support the center of the cooler. **DO NOT** sleeve a straight roof jack into the discharge opening of the cooler. Straight roof jacks must be equipped with a flange jack extender.

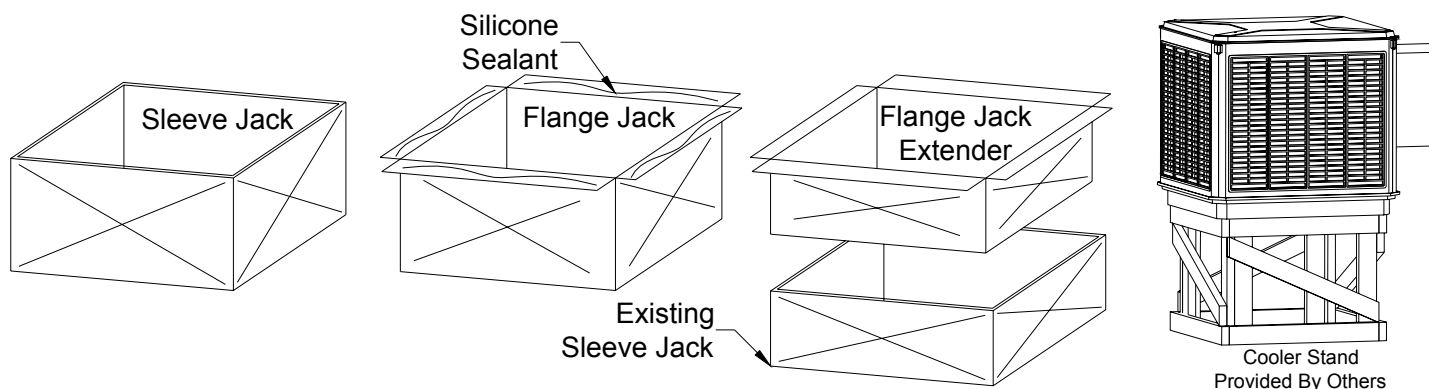

**Note 1:** To properly seal the cooler to the flanged jack and prevent air loss, put approximately a ¼" bead of silicone sealant on the full length of each flange before placing the cooler base on the jack.

**Note 2:** If you plan to use a flange jack extender, the extender should be fabricated so that it will fit inside the sleeve jack. Also, the extender should extend a minimum of 6" above the roof on the high side of the roof. Use two (2) self-tapping sheet metal screws per side to secure the extender to the existing duct.

### Tools and Supplies Needed

- |                              |   |                  |
|------------------------------|---|------------------|
| 1. Pliers                    | 6. Drill  | 11. Level        |
| 2. Screwdrivers              | 7. Hammer   | 12. Tin snips    |
| 3. Adjustable wrenches       | 8. Silicone sealant                                 | 13. Tape measure |
| 4. Tubing cutter or hacksaw  | 9. Sheet metal screws                               |                  |
| 5. 5/32 hex key allen wrench | 10. Wiring supplies as required by applicable codes |                  |

### Location and mounting requirements

- Do not install this cooler near a chimney or other roof vent. The fumes from these can be drawn into the cooler and blown back into your house.
  - Before mounting any cooler on a roof, steps must be taken to ensure that the roof will support the weight of the cooler. See the warranty page for the operational weight of this cooler.
  - If a hole is cut in the roof for the duct, the opening must be framed out in order to attach and support the duct. **The duct will support the entire weight of your Tradewinds cooler.** The legs only offer corner support and a means to level the cooler.
  - For Side Discharge units, a cooler stand must be provided to support the unit. **Tradewinds does not supply cooler stands.**
  - Unless otherwise indicated, Tradewinds coolers require a 20 amp, 120 volt AC circuit with a standard two-speed wiring circuit to the cooler.
  - Tradewinds coolers require a suitable ¼" water line. Install a shutoff valve at the beginning of the water line.
  - The duct openings are as follows
- |                    |                    |
|--------------------|--------------------|
| TC451 17 ¾" square | TC571 19 ¾" square |
| TS451 17 ¾" square | TS571 19 ¾" square |

**Louver latches**

The latches at the corners of your Tradewinds cooler are designed to hold the louvers securely in place and prevent gapping which degrades cooler performance.

- To unlatch the louvers for removal: Slip a flat head screwdriver under one corner of the latch and pry out gently. If you pry too hard or too quickly on the latch, it may pop out of place and fly off the unit resulting in a lost latch.
- Unlatch the louver at the four (4) corners. Remove the louvers one (1) at a time.
- Remove the louver by tilting it out at the top and lifting it away from the unit.
- To install the louver: place the louver into the slot in the cooler pan and tilt it up into place. Place the second louver adjacent to the first. Ensure that the embosses (in the corners of the louvers) fit together snugly. Close the latches over the embosses.
- Do not hit or force the louvers into place. If the louvers do not fit together easily, it may be that something is wrong with the installation.

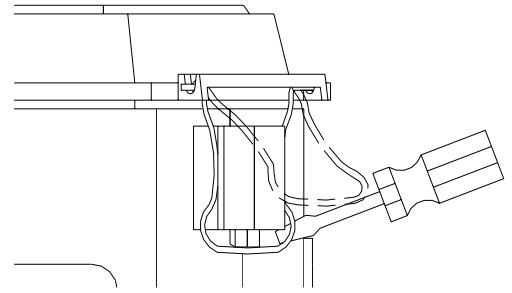

**The cooler must be level for proper operation**

To level your Tradewinds cooler, install a LEG EXTENSION KIT (provided on downdraft models only). **Refer to instructions included with the leg extension kit for installation.** If the cooler is to be placed on a stand, the LEG EXTENSION KIT need not be used. To check the cooler for level, place a level on the **cooler base**. DO NOT use the top of the cooler to check for level.

**Float valve**

On the downdraft models a flange has been molded into the backside of the blower near the water line. On the side draft models a flange has been molded into one of the vertical blower supports.

1. Remove the compression nut, ferrule, ring nut and fiber washer from the stem of the float.
2. Place the stem of the float through the hole in the flange.
3. Place the fiber washer over the stem of the float and thread the ring nut back on to the stem and tighten so the water outlet faces straight down.
4. Bring a suitable 1/4" water line into the cooler through the small hole provided in the base.
5. Place the compression nut and then the ferrule onto the water line.
6. Insert the water line into the stem of the float, slide the ferrule to the stem and thread the compression nut on to the stem. DO NOT over tighten the compression nut. If the fitting leaks, tighten the compression nut a little at a time until the leak stops.

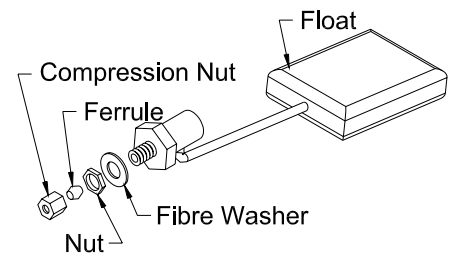

**Overflow fitting**

The water level should be adjusted so that it reaches 1/2" below the top of the overflow pipe. To allow for draining the pan, the bushing is threaded to accept a standard, female garden hose fitting.

1. Place the bushing, with the rubber washer, through the hole provided in the base of the cooler.
2. Secure from below the base with the ring nut provided. **DO NOT over tighten the ring nut.** This may damage the rubber washer and allow the fitting to leak.
3. Thread the overflow tube into the bushing and hand tighten. Over tightening the overflow tube may cause damage to the tube. If the fitting leaks and tube is properly tightened, try wrapping the threads of the tube with plumber's tape.

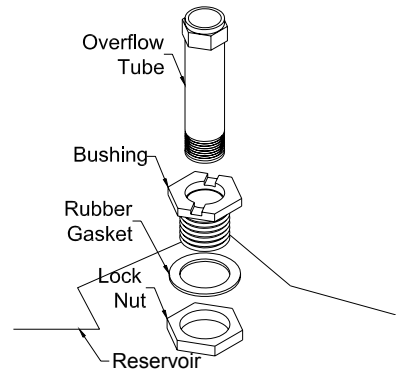

**Motor installation**

1. Remove the motor from the box, inspect for shipping damage and ensure that the horsepower and voltage are correct.
2. Remove the motor from the cradle provided. This will make installing the cradle easier.
3. Bolt the cradle to the motor mount using the carriage bolts and nuts provided.
4. Wire the motor cord to the motor.
  - a. Remove the cover plate from the back of the motor.
  - b. Wire the cord to the motor as shown.
  - c. Replace the cover plate so that only the black cord is visible (not the wires).
5. Replace the motor in the cradle and secure with the saddle clamps.

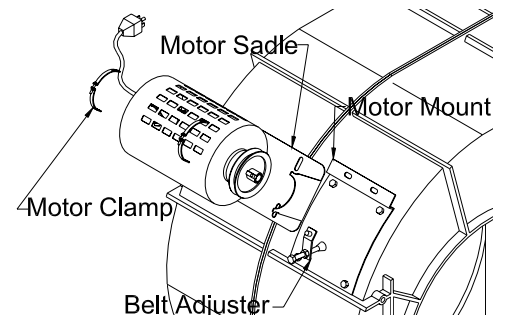

**Electrical connections**

Tradewinds coolers must be wired in accordance with applicable codes and regulations. If you are not familiar with local wiring codes, SEEK THE ASSISTANCE OF A LICENSED PROFESSIONAL ELECTRICIAN.

**WARNING: To reduce the risk of fire or electrical shock, do not use this fan with any solid-state speed control device.**

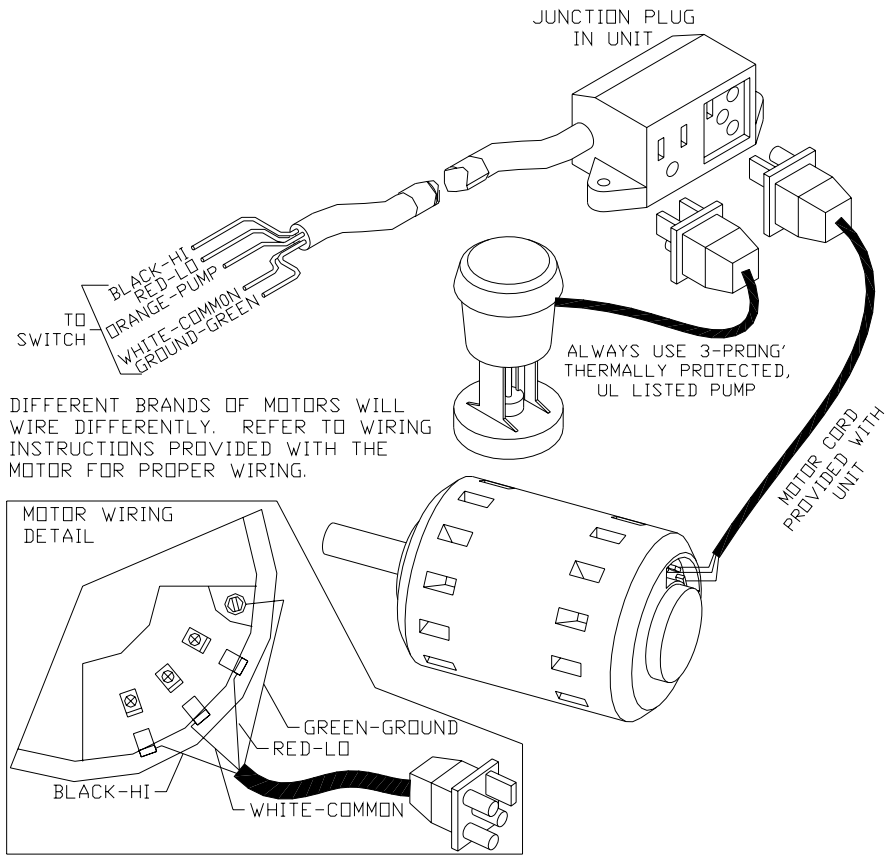

**Motor Pulley**

1. The motor pulley should be installed on the motor shaft with the threaded side out.
2. Align the motor pulley with the blower pulley.
3. Tighten the set screw A (5/32 hex screw) opposite the threaded side to secure the pulley to the shaft. Be sure to tighten the set screw onto the flat side of the shaft.
4. Loosen set screw B (5/32 hex screw) on the threaded side of the pulley. This will enable the outside jaw of the pulley to rotate.
5. Turn the outside jaw clockwise until the pulley is fully closed, then turn the 'outside jaw' counter-clockwise until the set screw is positioned over the nearest flat spot.
6. From the closed position, open the pulley (turn outside jaw counter-clockwise) 3 turns. Tighten the set screw. It is important that the set screw is not tightened onto the threads. **This will damage the pulley.**

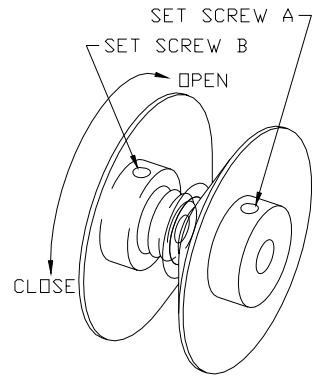

7. After the unit is fully installed, with the fan on HI speed, the pump off and all the louvers in place, check the motor amperage using an ammeter. The amperage should read what the manufacturer recommends on the motor name plate. If this is not the case, adjust the amperage by closing (increase amperage) or opening (decrease amperage) the pulley 1/2 turn. Recheck amperage after each adjustment. **To prevent motor damage, never exceed the amperage listed on the motor.**

## Belt installation and adjustment

To install belt:

1. Place the belt over the motor pulley.
2. Place the free end of the belt into the blower pulley.
3. Rotate the blower pulley until the belt lies fully in the groove.

### Ensure not to pinch fingers between the pulley and the belt

Test the belt tension by pressing on the belt mid-way between the pulleys. With only 3 to 4 pounds of pressure, you should be able to deflect the belt between  $\frac{3}{4}$  and 1 inch.

If the belt needs to be adjusted:

1. Push up on the motor to get an idea of how much the belt tension bracket should be adjusted.
2. To tighten the belt: Remove the belt and adjust the bracket accordingly.
3. To loosen the belt: Remove the belt and adjust the bracket accordingly.

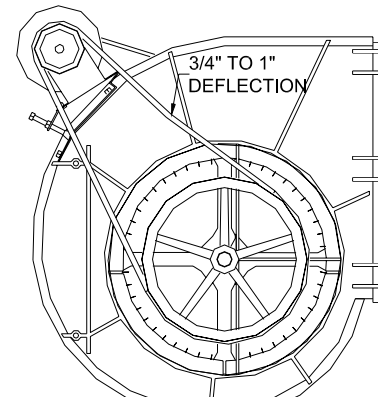

After the installation is complete, fill the cooler pan with water. Check for leaks at the drain coupling and the float valve coupling. Adjust the water level by resetting the adjustment screw at the base of the float rod. Check that the base of the cooler is level. To prevent rust a coating of good quality axle grease may be applied to the shaft and bearings.

## Post installation inspection

1. Cooler is securely fastened to the roof jack
2. Base is level (check after full of water)
3. Ensure duct is sealed
4. Check all connections for water leaks
5. Check for correct water level
6. Ensure all electrical connections and wiring conform to applicable codes and motor and pump are plugged into junction receptacle
7. Ensure motor is securely fastened to mount, the pulleys are aligned and the belt is tensioned properly
8. Ensure the hose is installed securely to the pump and to the water distributor
9. Turn on main power supply
10. Check pump operation by turning the control switch to PUMP ONLY. Check that all pads wet evenly
11. Check the high and low fan speeds with and without the pump running.

## Operation

- Before you put your new cooler into operation, pour a cap full of laundry fabric softener (any brand) into the water and run the cooler on PUMP ONLY for 10 to 15 minutes or until the pads are thoroughly saturated.
- You control the airflow of the cooler into what rooms you wish cooled. To allow cooling in a particular room, open a window, exterior door or vent in that room. The cool air from your cooler will tend to go to the rooms that have some sort of opening to allow for exhaust to the outside of the house.
- A rule of thumb used for deciding how far to open each window or how many windows to open is to allow 2 square feet of exhaust for each 1000 CFM of airflow. For example, the TC451 delivers 4100 CFM; therefore, you will need approximately 8 square feet of exhaust area.

## For replacement purposes...

**Pads:** Use only HiKool Plastic UL Class II evaporative pads.

**Pumps:** Use only three-pronged molded plug UL listed pumps 5000CFM for TS451 & TC451 – 7000CFM for TS571 & TC571.

**Motors:** use only evaporative cooler motors.  $\frac{1}{2}$  HP TS451 & TC451 –  $\frac{3}{4}$  HP TS571 & TC571.

## Maintenance

**Warning:** Always shut off the electrical power to the unit at the fuse or breaker box and unplug the motor, pump from the junction receptacle and shutoff the water supply before attempting any type of maintenance or service work.

## Oiling

1. Oil the bearings and motor often (twice a season minimum).
2. The bearings are provided with oil cups. Lift the hinged lid on the cup and add a couple of drops of oil. Do not over oil, excessive oil can enter the air stream.
3. If the motor is provided with oil cups, then oil the motor when you oil the bearings. Do not over oil, if oil gets into the motor, damage may occur.

## Cleaning the water distributor

1. Disconnect the vinyl tubing connecting the pump and water distributor.
2. Turn the water distributor clamps in the top of the cooler, lower the distributor and pull (twist) apart at the tan connectors.
3. Tap ends lightly on a hard surface to dislodge mineral deposits and flush with a garden hose.
4. A nail may be used to clean deposits from the holes in the distributor. DO NOT distort or enlarge holes while cleaning.

Do not attempt to clean the water distributor while on the roof.

## Mineral build up

- Mineral deposits may collect on the louvers and around the base of the cooler. These deposits may be removed easily with a little water and a nylon scrub brush (never use a wire brush on this cooler).
- In areas with concentrated minerals in the water, change the water often to prevent high mineral content in the reservoir.
- An inline water filter device, installed on the water line, will help keep mineral build up to a minimum.
- Change the pads when they become mineral laden and dirty. In most areas, a set of pads will not last all season.

**Post season**

Perform this maintenance as soon as possible after the last day of usage or when shutting down the cooler for extended periods.

1. Drain water
2. Remove pump
3. Clean mineral deposits from pan and louvers
4. Remove the belt and hang it from the motor pulley
5. Cover the cooler with a high quality cooler cover to keep dirt and water out of cooler

**Pad removal and installation**

For safety reasons, do not attempt to change the pads on the roof.

1. Unhook pad retainers above and below pad. Remove and set aside.
2. Remove old pad and discard.
3. Place the new pad in the louver so that the top of the pad covers at least 1/2 of the water tray slots. Center the filter over the pad.
4. Replace pad retainers.

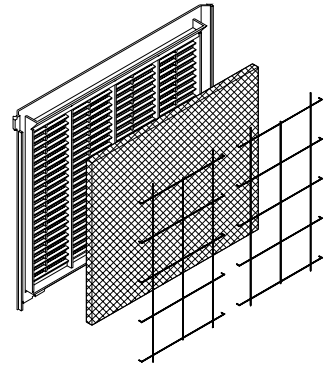

**TRADEWINDS LIMITED LIFETIME WARRANTY**

Tradewinds Technologies, Inc. ("Tradewinds") provides to each original purchaser of the evaporative cooler (the "Product") the cabinet parts consisting of the top cap, base, louvered air panels, and blower housing a LIMITED LIFETIME warranty against warping, heat distortion, stress cracking, and defects in workmanship or materials, but only if normal function of the product is inhibited by the defect. Internal and external components of the Product (including the water pump) are warranted for a period of one (1) year from the date of purchase to be free of defects in workmanship or material. This Limited Warranty shall not apply to any Product which has been subject to misuse, negligence, accident, or which has not been installed in a good workmanlike manner. Labor, postage and/or freight are not included in this Limited Warranty. Replacement of pads is a normal maintenance function and not covered by this Limited Warranty.

ALL WARRANTY CLAIMS FIRST SHOULD BE PROCESSED THROUGH THE SELLING AGENT FROM WHOM THIS PRODUCT WAS ORIGINALLY PURCHASED. ALL WARRANTY WORK MUST BE APPROVED THROUGH TRADEWINDS OFFICES AT 5800 MURRAY STREET, LITTLE ROCK, AR 72209, (800) 643-8341.

THE REMEDIES PROVIDED IN THIS LIMITED WARRANTY SHALL BE THE SOLE AND EXCLUSIVE REMEDIES FOR ANY BRANCH OF THIS LIMITED WARRANTY AND IN NO EVENT SHALL TRADEWINDS BE LIABLE FOR ANY INCIDENTAL OR CONSEQUENTIAL DAMAGES RESULTING FROM ANY BREACH OF THIS LIMITED WARRANTY.

Some states do not allow the exclusion or limitation of incidental or consequential damages, so the above exclusion may not apply to the purchaser. This Limited Warranty gives you specific legal rights and you may also have other rights which vary from state to state.

**TRADEWINDS WARRANTY GUIDELINES**

**TRADEWINDS RESPONSIBILITIES**

Tradewinds provides the cabinet parts including the top cap, base, louvered air panels and blower housing a LIMITED LIFETIME against defects in workmanship or materials.

Tradewinds warrants the internal and external components of the product for one (1) year from the date of purchase to be free of defects in workmanship or materials.

Tradewinds warrants the water pump, blower wheel, shaft, bearings, and electrical components for one (1) year against defects in workmanship or materials.

**PURCHASER'S RESPONSIBILITIES**

- Labor charges to replace defective parts.
- Postage or freight on defective parts.
- Parts defective from misuse, negligence or accident.
- Labor charges to replace defective components.
- Labor charges to replace defective pump, blower wheel or motor.
- Pad replacement.
- Product maintenance.
- Correction of improper installation.
- Wiring to house current and switch or thermostat.

**Cooler weight**

Model	TC451	TC571	TS451	TS571
Shipping weight	150 lbs.	191 lbs.	167 lbs.	202 lbs.
Water capacity	11 gal.	14 gal.	7 gal.	10 gal.
Operational weight	248 lbs.	316 lbs.	213 lbs.	291 lbs.

Item	Description	Descripción	Qty	Part No.	
				No. de Ref.	
				TS451	TS571
1	Top	Superior	1	41C04	51C04
2	Bottom	Fondo	1	41C03	51C03
3	Front	Frente	1	41C06	51C06
4	Support Bracket Set	Juego de ménsulas de soporte		41C07	41C07
5	Louver Clip	Presilla de parrilla	4	60CC	60CC
6	Right Blower Side	Soplador lado derecho	1	41C01	51C01
7	Left Blower Side	Soplador lado izquierdo	1	41C02	51C02
8	Blower Wheel	Rueda de soplador	1	46BW4	56BW5
9	Blower Shaft	Eje de soplador	1	46S22	56SS1
	Blower Assembly	Soplador la asamblea	1	41BHU	51BHU
10	Set Collar	Juego de collar	2	60SC1	60SC1
11	Leather Washer	Arandela de cuero	4	60LW	60LW
12	Bearing	Cojinete	2	60PBS	60PBS
13	Blower Pulley	Polea de soplador	1	46BP4	56BP5
14	Shaft Plug	Tapón del eje	2	60SP1	60SP1
15	Belt	Correa	1	582085	582001
16	Motor Mount	Montaje para motor	1	60MMB	60MMB
17	Louver	Parrilla	3	41C05	51C05
18	Filter Set	Filtro Set	1	41HPS	51HPS
19	Pad Retainer	Retentor de almohadilla	6	45SPR	57SPR
20	Motor Clamps	Grapas para Motor	2	60MRC	60MRC
21	Motor	Motor	1	50310	30491
22	Motor Pulley	Polea del Motor	1	30316	30316
23	Belt Adjuster	Ajustador de correa	1	60BA1	60BA1
24	Motor Saddle	Asiento del motor	1	60MAB	60MAB
25	Motor Cord	Cordón para motor	1	60MC1	60MC1
26	Water Hose	Manguera de agua	1	60VT1	60VT1
27	Water Hose Adapter	Adaptador de manguera de agua	1	60HC1	60HC1
28	Water Distributor	Distribuidor de agua	1	41WR1	51WR5
29	Overflow Kit	Juego de rebasamiento	1	70613	70613
30	Float Valve	Válvula flotadora	1	70BFV	70BFVL
31	Pump Mount	Montaje para bomba	1	60PS1	60PS1
32	Pump	Bomba	1	46P1/70725	56P1/70726
33	Wiring Harness	Arnés de cableado	1	60RX	60RX
34	Water Strip	Rege la Tira	3	41WS	51WS

TS451 & TS571  
REPLACEMENT PARTS  
REPUESTOS  
600M1

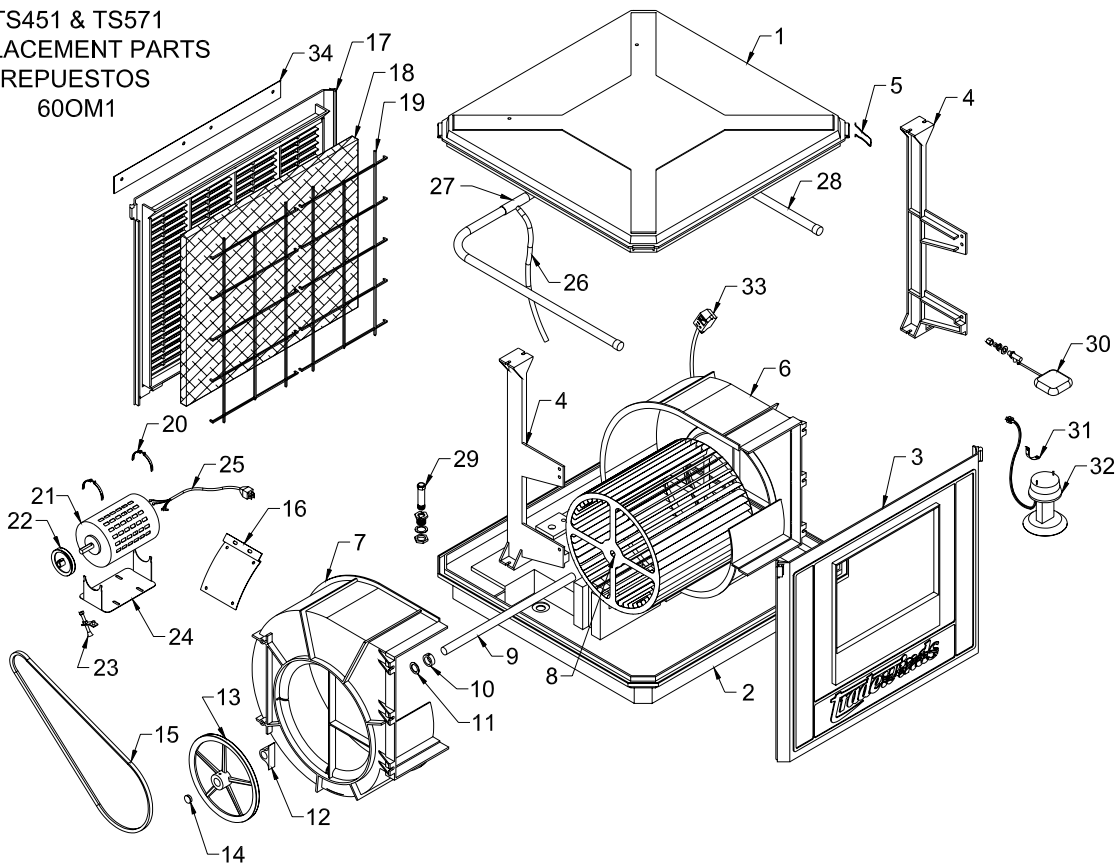

TC451 & TC571  
REPLACEMENT PARTS  
REPUESTOS  
600M2

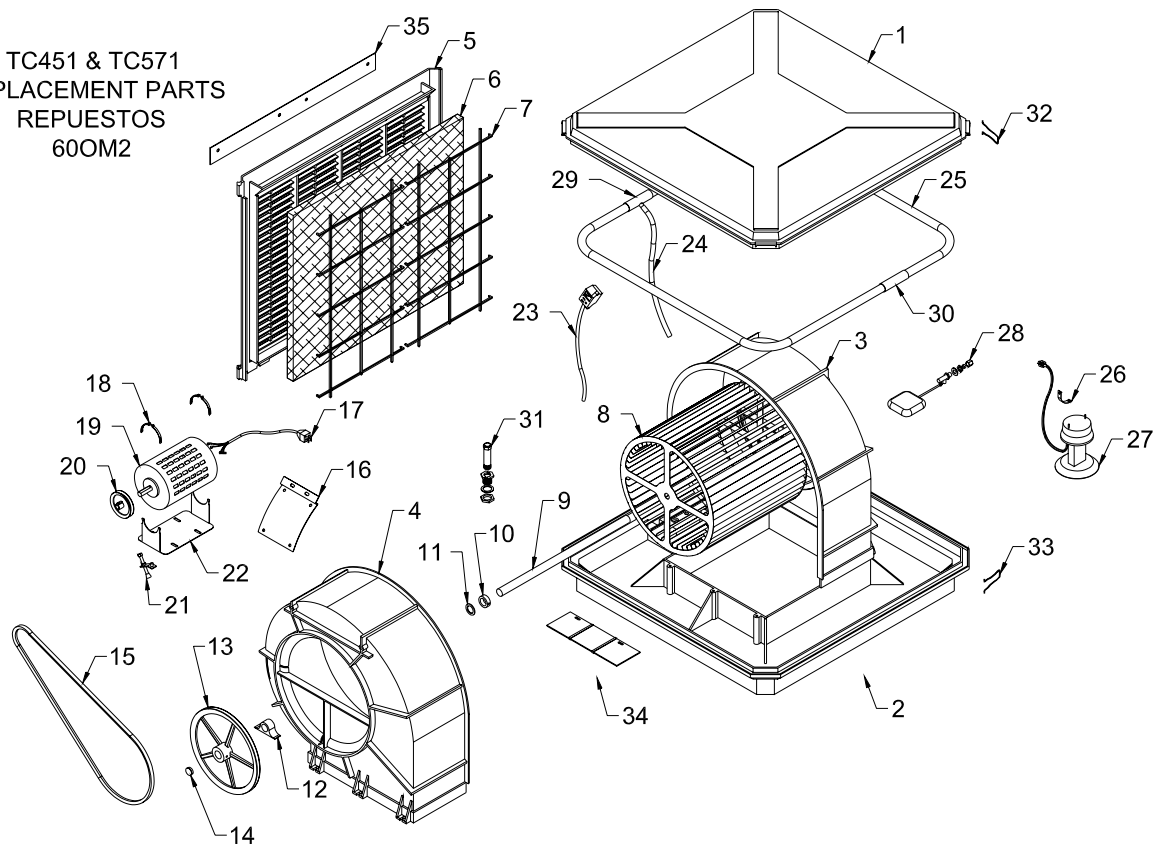

Item	Description	Descripción	Qty	Part No.	
				No. de Ref.	
				TC451	TC571
1	Top	Superior	1	46C04	56C04
2	Bottom	Fondo	1	46C03	56C03
3	Right Blower Side	Soplador lado derecho	1	46C01	56C01
4	Left Blower Side	Soplador lado izquierdo	1	46C02	56C02
	Blower Assembly	Soplador la asamblea	1	46BHU	56BHU
5	Louver	Parrilla	4	46C05	56C05
6	Filter Set	Filtro Set	1	46HPS	56HPS
7	Pad Retainer	Retentor de almohadilla	6	45CPR	57CPR
8	Blower Wheel	Rueda de soplador	1	46BW4	56BW5
9	Blower Shaft	Eje de soplador	1	46S22	56SS1
10	Set Collar	Juego de collar	4	60SC1	60SC1
11	Leather Washer	Arandela de cuero	2	60LW	60LW
12	Bearing	Cojinete	2	60PB	60PB
13	Blower Pulley	Polea de soplador	1	46BP4	56BP5
14	Shaft Plug	Tapón del eje	2	60SP1	60SP1
15	Belt	Correa	1	582030	582047
16	Motor Mount	Montaje para motor	1	60MMB	60MMB
17	Motor Cord	Cordón para motor	1	60MC1	60MC1
18	Motor Clamps	Grapas para Motor	2	60MRC	60MRC
19	Motor	Motor	1	50310	30491
20	Motor Pulley	Polea del Motor	1	30316	30316
21	Belt Adjuster	Ajustador de correa	1	60BA1	60BA1
22	Motor Saddle	Asiento del motor	1	60MAB	60MAB
23	Wiring Harness	Arnés de cableado	1	60RX	60RX
24	Water Hose	Manguera de agua	1	60VT1	60VT1
25	Water Distributor	Distribuidor de agua	1	46WR4	56WR5
26	Pump Mount	Montaje para bomba	1	60PS1	60PS1
27	Pump	Bomba	1	46P1/70725	56P1/70726
28	Float Valve	Válvula flotadora	1	70BFV	70BFV
29	Water Hose Adapter	Adaptador de manguera de agua	1	60HC1	60HC1
30	Coupling	Coupling	1	60WRC	60WRC
31	Overflow Kit	Juego de rebasamiento	1	70613	70613
32	Louver Clip	Presilla de parrilla	4	60CC	60CC
33	Bottom Louver Clip	Presilla de parrilla	4	60CCB	60CCB
34	Splash Baffle	Deflector	2	60SG1	60SG1
35	Water Strip	Rege la Tira	4	46WS	56WS