

This Owner's Manual is provided and hosted by [Appliance Factory Parts](#).



FRIEDRICH WET10A33A-C Owner's Manual

**[Shop genuine replacement parts for FRIEDRICH
WET10A33A-C](#)**



[Find Your FRIEDRICH Air Conditioner Parts - Select From 1575 Models](#)

----- Manual continues below -----



FRIEDRICH

Thru-the-Wall Conditioners

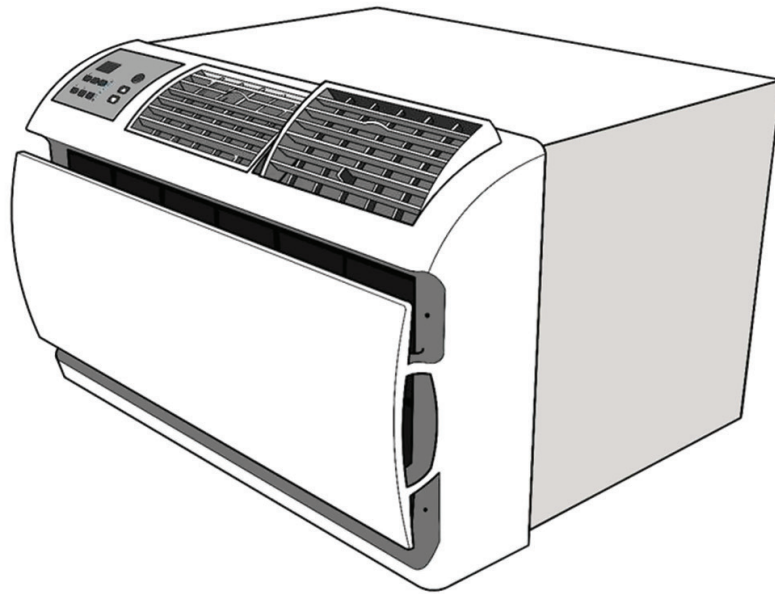

Air Conditioners and Heat Pumps

WallMaster®

115-Volt: WCT08, WCT10, WCT12

230-Volt: WCT10, WCT12, WCT16, WET10, WET12,
WET16, WHT12

Thank you for your decision to purchase the Friedrich High Efficiency Air Conditioner. Your new Friedrich has been carefully engineered and manufactured to give you many years of dependable, efficient operation, maintaining a comfortable temperature and humidity level. Many extra features have been built into your unit to assure quiet operation, the greatest circulation of cool, dry air, and the most economic operation.

THANK YOU, on behalf of our entire company, for making such a wise purchase.

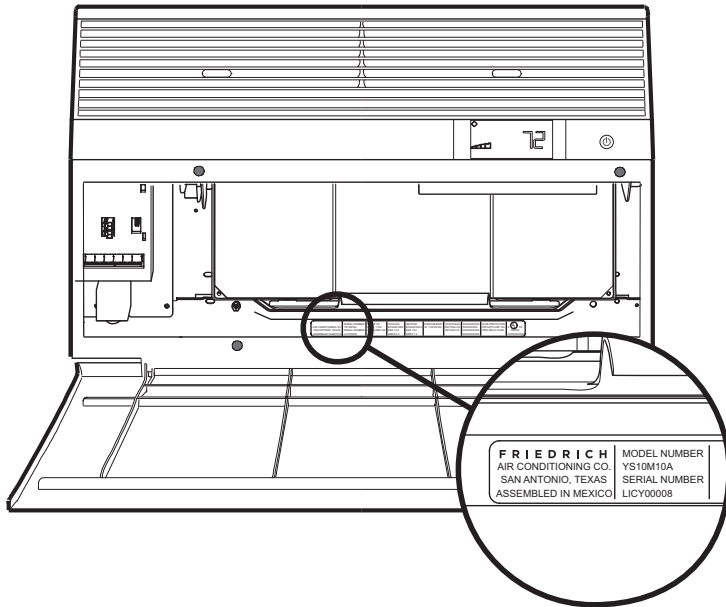

Register your air conditioner

Model information can be found on the name plate behind the front cover.

Please complete and mail the owner registration card furnished with this product, or register online at www.friedrich.com.

For your future convenience, record the model information here.

MODEL NUMBER

SERIAL NUMBER

PURCHASE DATE

Safety Precautions

Your safety and the safety of others is very important.



We have provided many important safety messages in this manual and on your appliance. Always read and obey all safety messages.

This is a safety Alert symbol.
This symbol alerts you to potential hazards that can kill or hurt you and others.

 **WARNING**

All safety messages will follow the safety alert symbol with the word "WARNING" or "CAUTION". These words mean:

Indicates a hazard which, if not avoided, can result in severe personal injury or death and damage to product or other property.

 **CAUTION**

Indicates a hazard which, if not avoided, can result in personal injury and damage to product or other property.

All safety messages will tell you what the potential hazard is, tell you how to reduce the chance of injury, and tell you what will happen if the instructions are not followed.

NOTICE

Indicates property damage can occur if instructions are not followed.

 **WARNING**





Refrigeration system under high pressure

Do not puncture, heat, expose to flame or incinerate.

Only certified refrigeration technicians should service this equipment.

R410A systems operate at higher pressures than R22 equipment. Appropriate safe service and handling practices must be used.

Only use gauge sets designed for use with R410A. Do not use standard R22 gauge sets.

THINK	 WARNING	 AVERTISSEMENT	 ADVERTENCIA
SAFETY FIRST	Do not remove, disable or bypass this unit's safety devices. Doing so may cause fire, injuries, or death.	Ne pas supprimer, désactiver ou contourner cette l'unité des dispositifs de sécurité, faire vous risqueriez de provoquer le feu, les blessures ou la mort.	No eliminar, desactivar o pasar por alto los dispositivos de seguridad de la unidad. Si lo hace podría producirse fuego, lesiones o muerte.

Standard Filter Cleaning / Installation Instructions

HOW TO CLEAN YOUR AIR FILTER

Your Friedrich room air conditioner is equipped with a permanent/ washable mesh air filter. The filter serves to remove dust, pollen, and other impurities from the air.

CHECK FILTER LIGHT

Your Friedrich room air conditioner is equipped with a check filter light that will illuminate after *45–60 days of fan operation.

To reset the CHECK FILTER reminder press the CHECK FILTER button. (While the reminder is set for 45–60 days of operation, we recommend checking the filter every 30 days for optimal performance.)

*Actual timer is set for 1000 hours of fan cycle operation.

FILTER ACCESS

Remove the FRONT PANEL. Using the handles, pull panel out until it is released from the two retaining snaps. Place the cover aside carefully. Remove the filter by pulling it from the handles releasing it from the slots on the frame. Wash the filter with water to remove all dust and then rinse, remove water excess and let it dry – **do not twist** – then replace the filter by inserting each tab in their respective slot.

Replace the FRONT PANEL by positioning one of the sides in the snaps of the handle first and then the other side, make sure that both snaps are correctly aligned and the logo is in the right position.

Figure 2

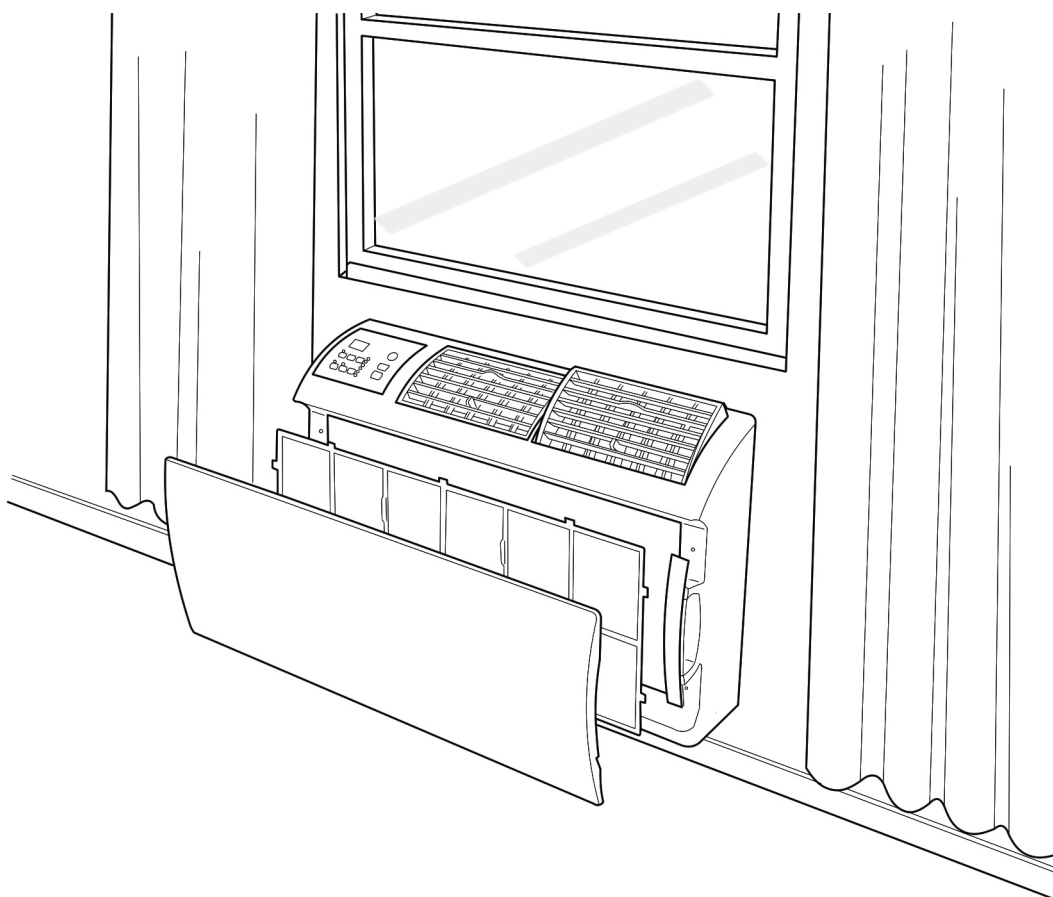

FRR071

Control Panel Operation

Accessing Sub-Menus

The leftmost MENU button accesses the sub-menu. See Figure 5.

The arrow buttons navigate the 6 menu options (See Figure 6):

- LIM
- LOCK
- TM
- CnCT
- F-C
- diAG

The rightmost button exits the menu. See Figure 7.

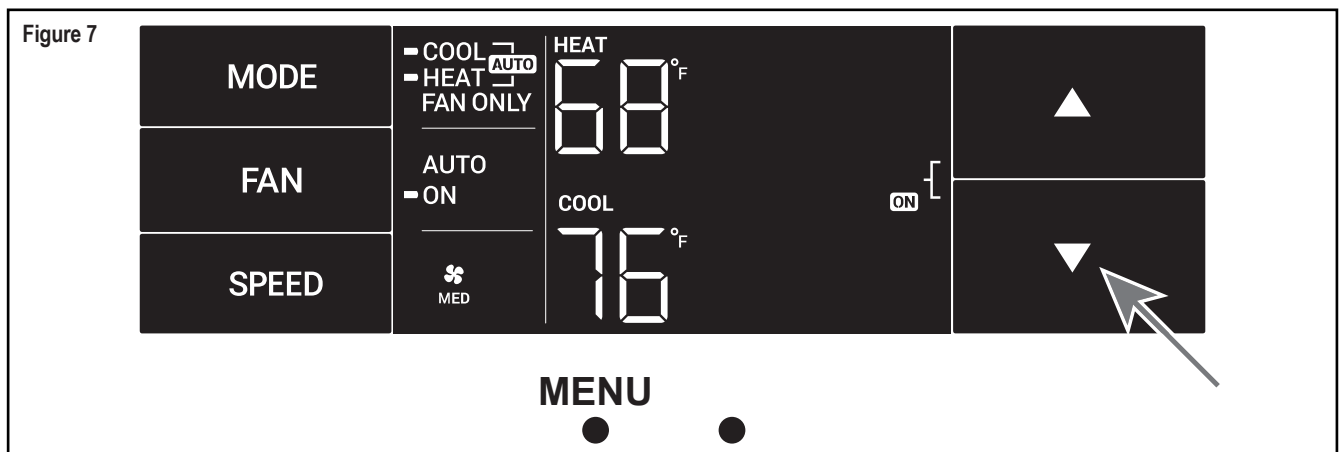
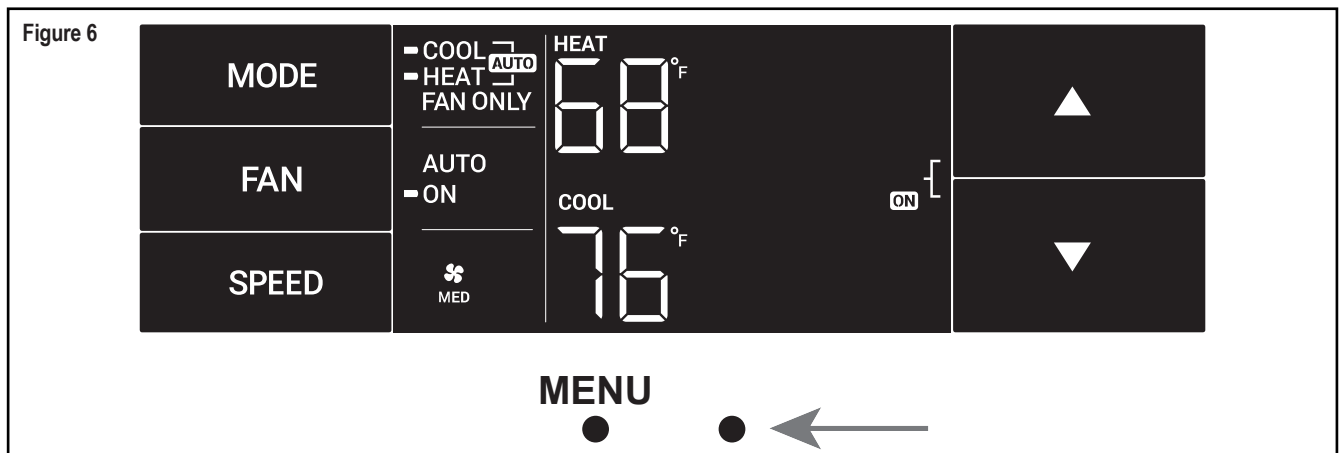
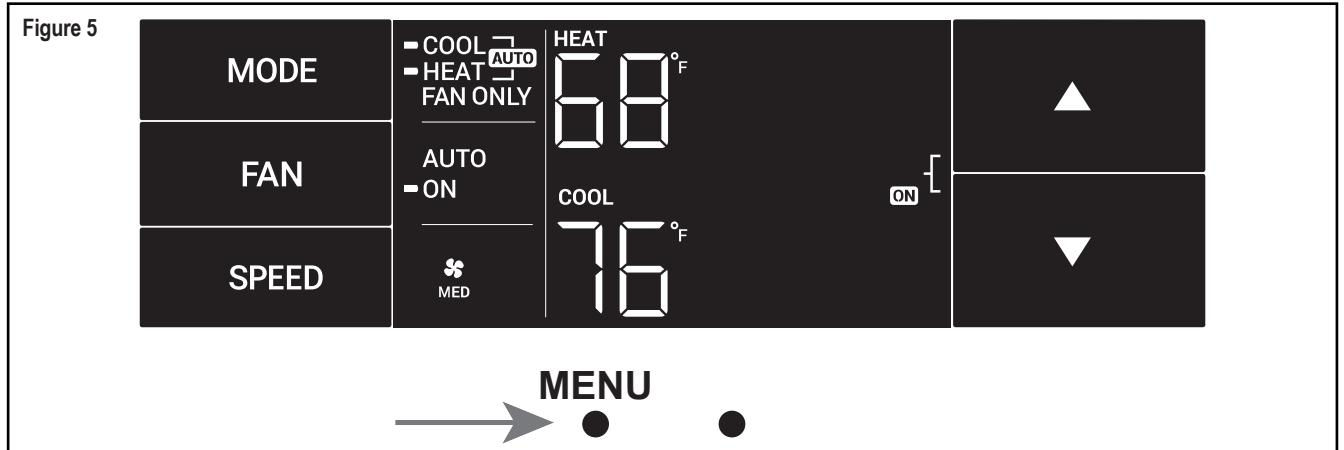

Control Panel Operation

The LIM Menu

This is the limit menu. See Figure 10.

Upon entering the menu, the first option will be to set the lower setpoint limit using the arrow buttons. See Figure 11.

Then you can set the higher setpoint limit using the arrow buttons. See Figure 12.

Pressing the leftmost button completes the limit setting. See Figure 13.

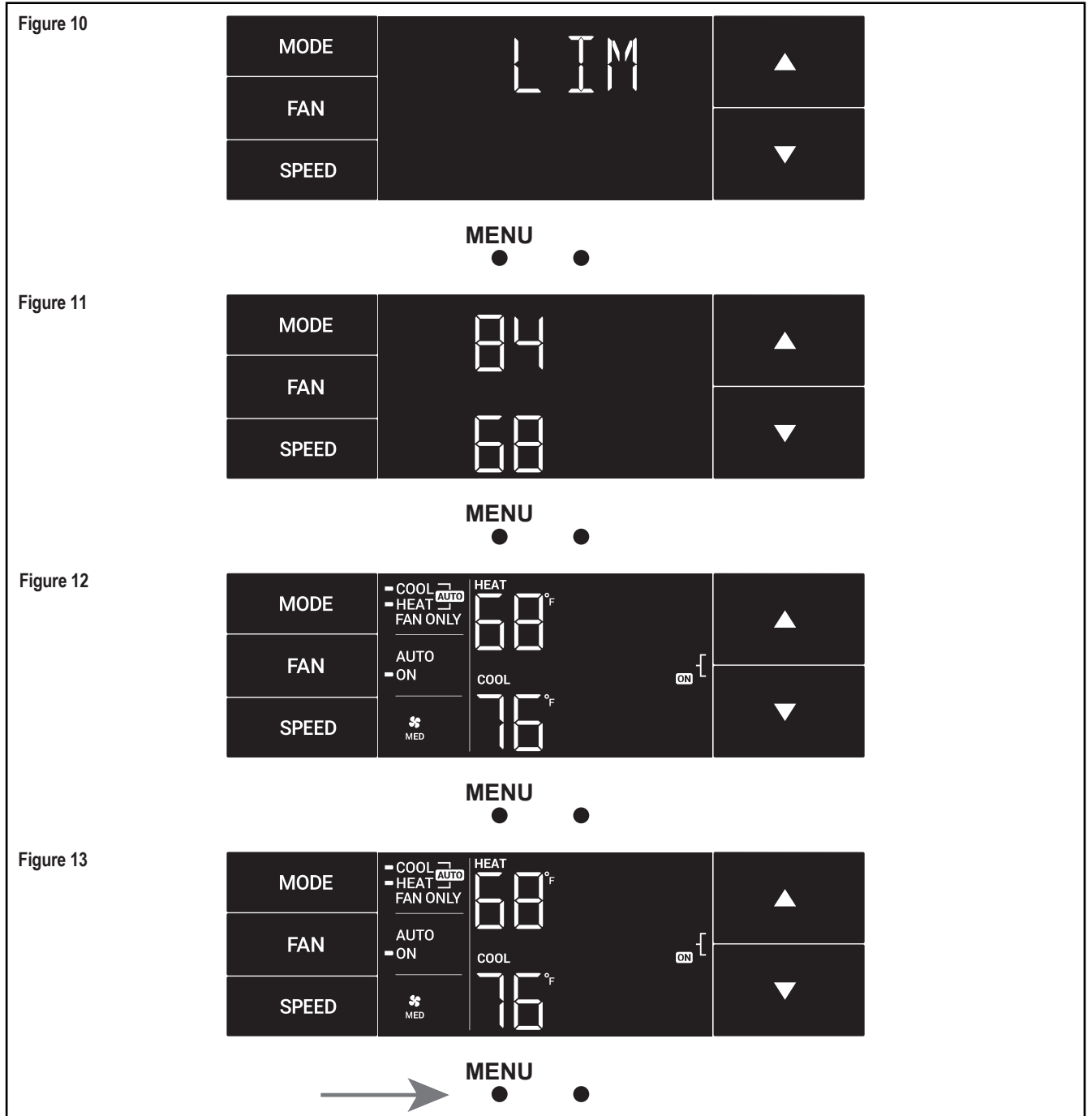

Control Panel Operation

The TM Menu continued

Auto mode selected. See Figure 18.

Note: The auto mode timer sets both the cool and heat setpoint.

Set the cool setpoint for your first timer period using the arrow buttons. The cooling mode timer only sets the cool setpoint. See Figure 19.

Set the time to start the first timer period. See Figure 21.

Next, set the heat setpoint for your first timer period. The heating mode timer only sets the heat setpoint. See Figure 20.

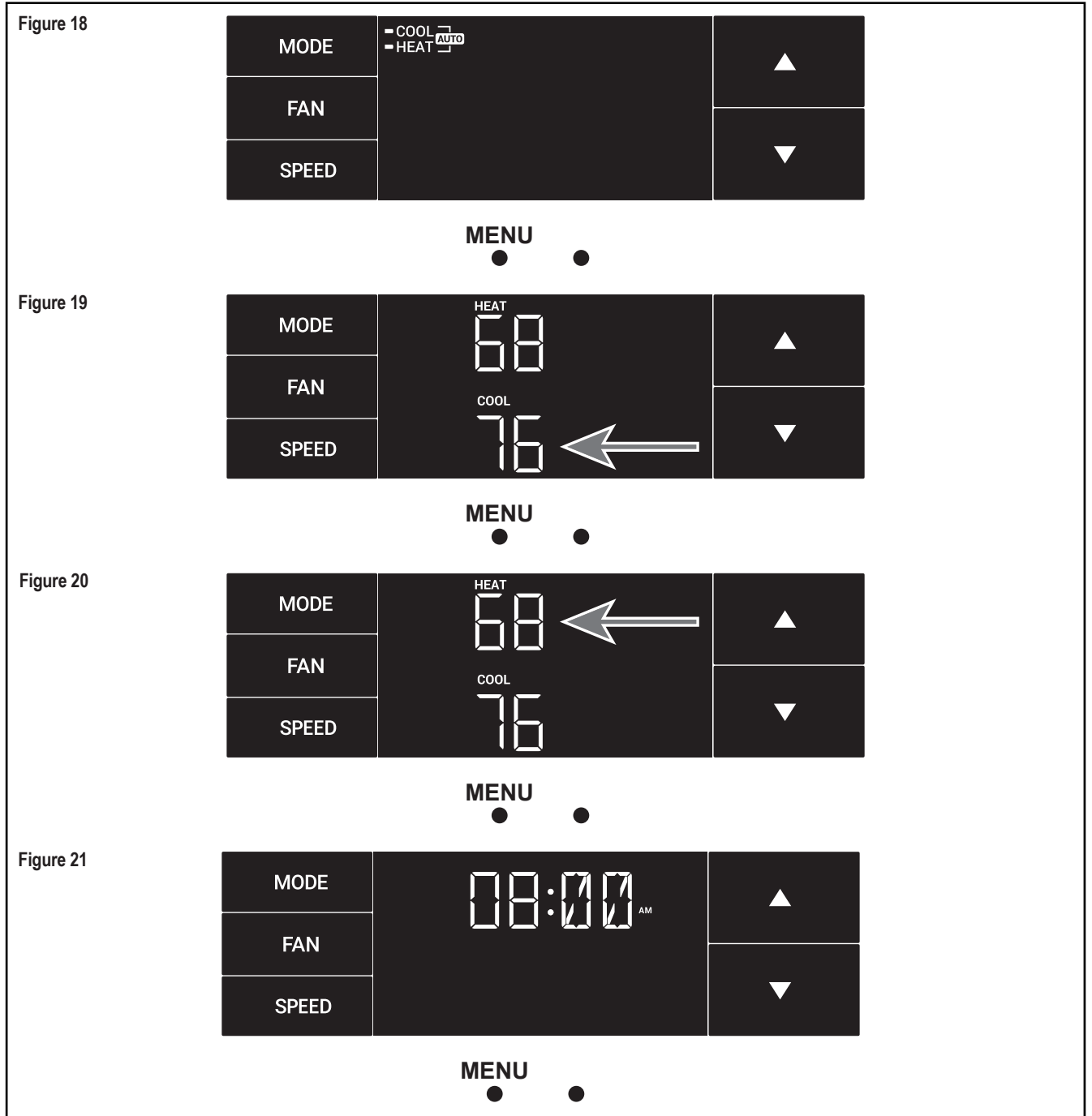

Control Panel Operation

The F-C Menu

This menu is used to toggle between Fahrenheit and Celsius.

This is the Fahrenheit/ Celsius Menu. See Figure 25.

Using the arrow buttons on the right side switches it from Fahrenheit to Celsius. See Figures 26 and 27.

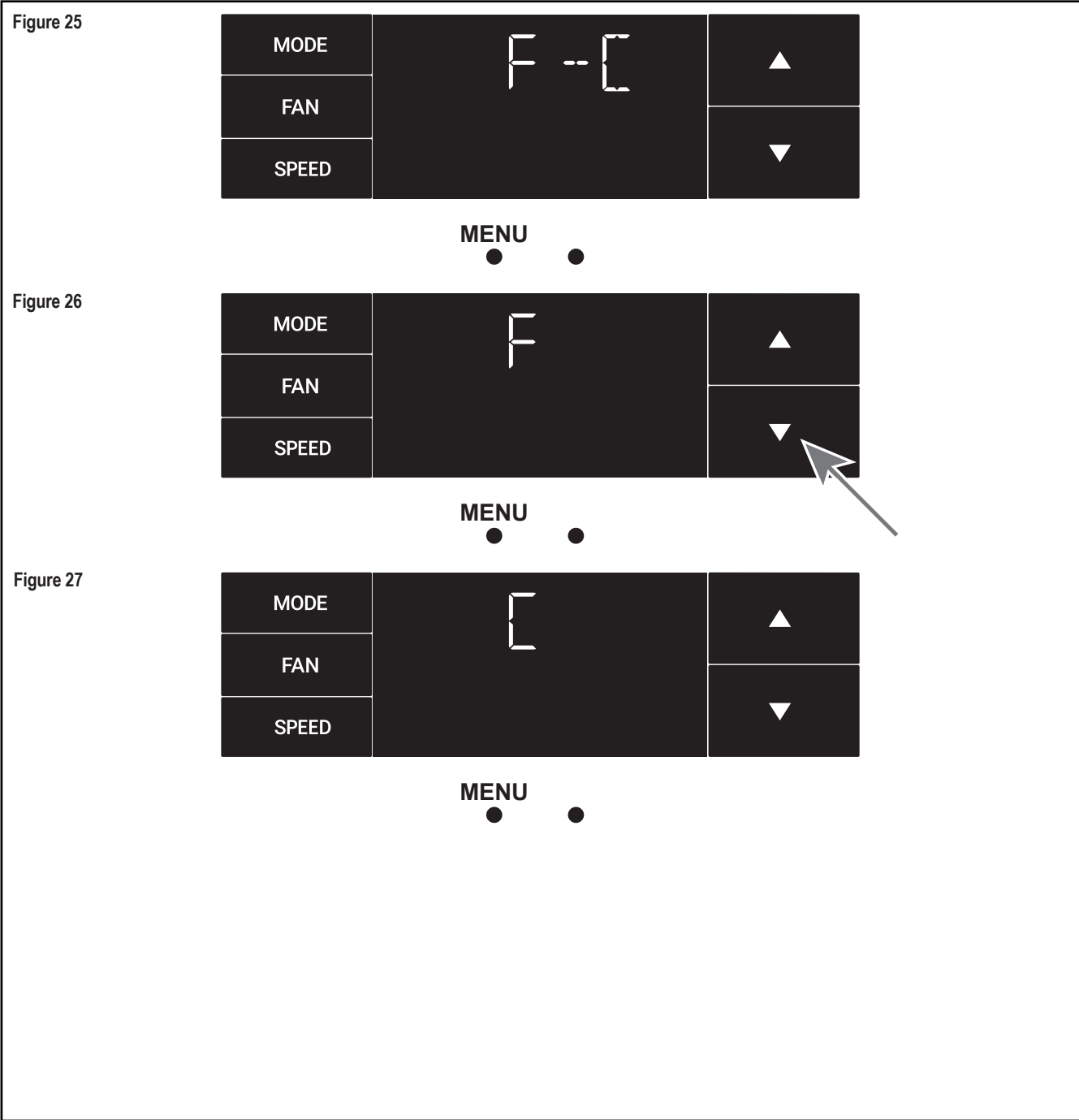

Control Panel Operation

The Lock Menu continued

Set the second digit of the password using the same method.
See Figure 32.

Set the third digit of the password using the same method.
See Figure 33.

Set the fourth digit of the password using the same method.
See Figures 34.

Press the leftmost button to complete the password process.
See Figure 35.

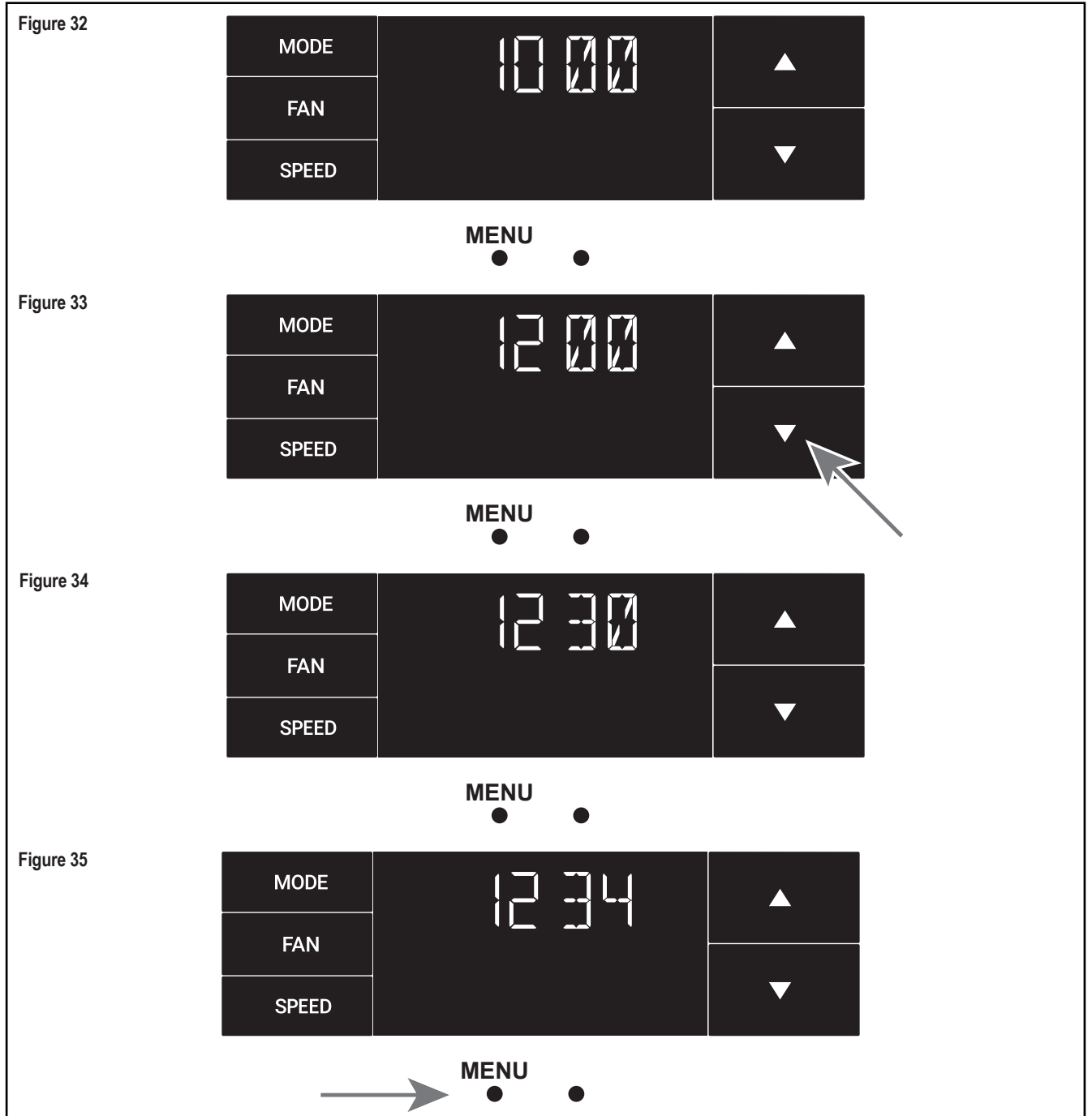

Control Panel Operation

The CnCT Menu

This menu is used to turn on Wi-Fi connection.

This is the CnCT menu. Pressing the leftmost button will activate Wi-Fi. See Figure 40.

The Wi-Fi symbol in the top right corner of the display shows Wi-Fi connection is on. See Figure 41.

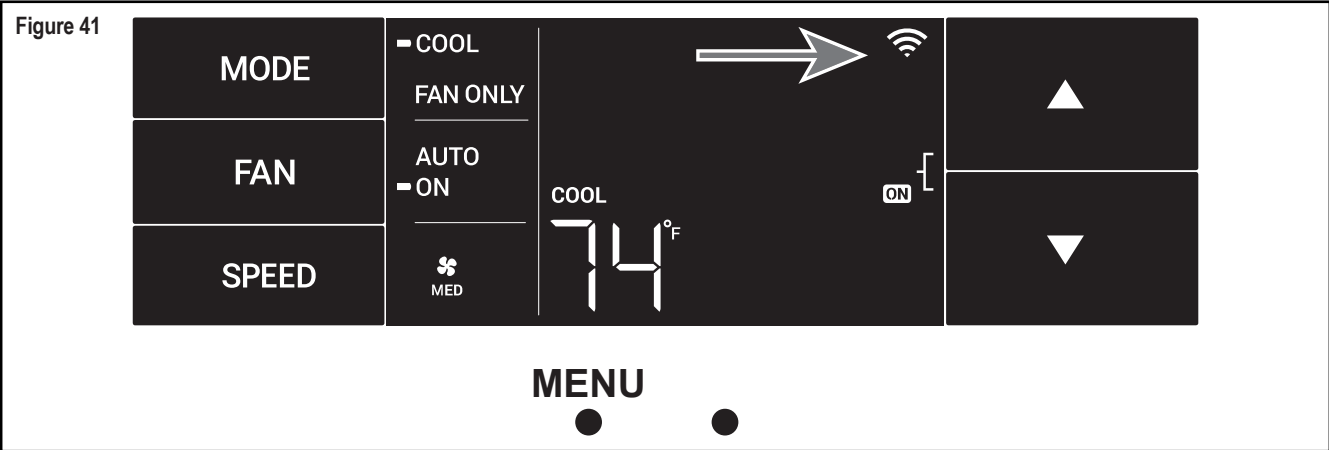
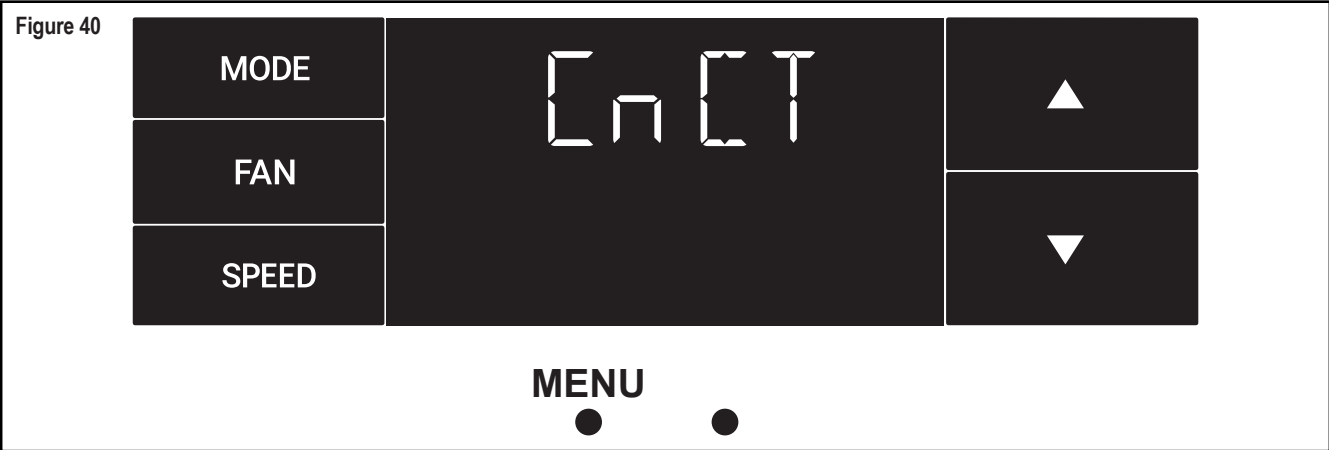

New WallMaster® Control Options

The new WallMaster gives you a variety of options for control, programming, and scheduling including wireless capabilities.

Wireless Programming and Control:

Friedrich Connect allows you to conveniently control, program, and monitor your air conditioning unit remotely from a smartphone or computer.

Pre-Programmed Scheduling Options:

Your unit's digital control comes equipped with a 24-hour timer.

24-Hour Timer

The 24-hour timer allows you to set 2 temperature changes at pre-set times or a unit control panel.

Customizable Programming Options:

Customizable timers, with up to four temperature adjustments per day, can be set using Friedrich Connect for one or multiple units.

See www.friedrich.com for complete details on Friedrich Connect.

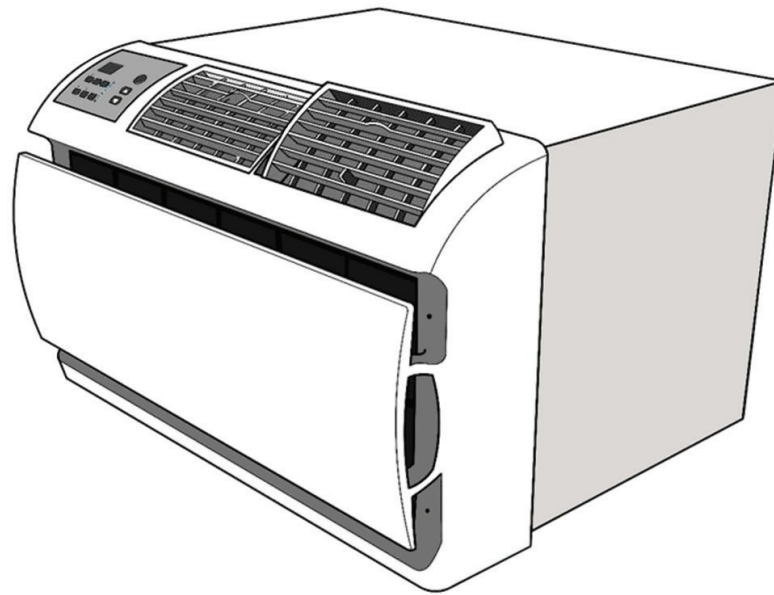

Control Panel Operation Instructions

SYSTEM - The **MODE** button allows you to sequentially select up to four modes of operation:

- AUTO** Available on select models
- COOL**
- HEAT** Available on select models
- FAN ONLY**

AUTO FAN (No Cooling Demand)

When in **AUTO** mode, the fan only operates when the system has a demand to cool or heat the room.

In the **ON** fan mode, the fan operates all the time. The system periodically cools or heats the fan's airflow but the flow of air does not stop.

UP and DOWN Arrows - Pressing either an **UP** or **DOWN** button changes the system's setpoint (desired room temperature). These buttons are also used to make system parameter changes later in this manual.

One press equals 1 degree of change in Fahrenheit mode. One press equals 0.5 degree change in Celsius mode.

TIMER

The timer can be engaged or disengaged from the control panel. This is done by pressing or holding the **UP** and **DOWN** arrows simultaneously for three seconds.

OTHER FUNCTIONS

°F–°C Select

To switch from degrees Fahrenheit (F) to Celsius (C), press the **MENU** button and enter the **F-C** sub-menu.

FAN SPEED - Depending on your model, the **FAN SPEED** button allows you to toggle between three or four modes of operation: **LOW**, **MEDIUM**, **HIGH** and **MAX**.

Alerts

When the filter needs to be cleaned or replaced, the **CHECK FILTER** icon displays.

The alert can be dismissed by pressing the **FAN MODE** and **TIME** for 3 seconds.

Lock Control Panel

To lock/unlock the front panel controls, navigate to the "**LOCK**" sub-menu found after clicking the **MENU** button. The lock requires a four digit pass code to lock/unlock the unit. This pass code will be required to enter the menu to unlock the unit. The **LOCK** icon illuminates to indicate the locked status.

The **LOCK** icon disappears to indicate unlocked status.

External Control Status

The **Wi-Fi** icon illuminates to indicate that the system is receiving a Wi-Fi connection. The **Wi-Fi** icon also provides information about the signal strength.

ADVANCED FUNCTIONS



The functions mentioned in the following section may or may not be available depending on the air conditioner model.



Modify the TIMER Function

Navigate to the **TIME** menu to set the timer.

Installation Instructions

READ THIS FIRST! Electrical Requirements

 WARNING	
	<p>Electrical Shock Hazard</p> <p>Make sure your electrical receptacle has the same configuration as your air conditioner's plug. If different, consult a Licensed Electrician.</p> <p>Do not use plug adapters. Do not use an extension cord. Do not remove ground prong.</p> <p>Always plug into a grounded 3 prong outlet. Failure to follow these instructions can result in death, fire, or electrical shock.</p>

 WARNING	
	<p>MOVING PARTS HAZARDS</p> <ul style="list-style-type: none"> Do not operate unit out of sleeve or with front grille removed. Do not place hands in blower or fan blade areas. <p>Failure to do so can result in serious injury.</p>

 CAUTION	
	<p>Excessive Weight Hazard</p> <p>Use two or more people when installing your air conditioner.</p> <p>Failure to do so can result in back or other injury.</p>

IMPORTANT: Before you begin the actual installation of your air conditioner, check your local electrical codes and the information below. Your air conditioner must be connected to a power source with the same alternating current (A.C.) voltage and amperage as marked on the name plate located on the chassis. Only A.C. can be used. Direct Current (D.C.) cannot be used.

CIRCUIT PROTECTION – Use on single outlet circuit only. An overloaded circuit will invariably cause malfunction or failure of an air conditioner; therefore, it is necessary that the electrical protection is adequate. Due to momentary high current demand when the air conditioner starts, use a "TIME DELAY" fuse or a HACR type circuit breaker. Consult your dealer or power company if in doubt.

Refer to the electrical name plate located on the air conditioner chassis (see Page 2) to determine the correct fuse or circuit breaker amperage for your model (see Table 1 on Page 5 for electrical receptacle types).

The power cord has a plug with a grounding prong and a matching receptacle is required.

Recommended Tools
1. Power Drill
2. 5/32" Drill Bit
3. Gloves
4. Carpenters Level
5. 5/16" Wrench
6. 1/4" Wrench
7. #2 Phillips Screw Driver
8. Putty Knife or (wood stir stick)

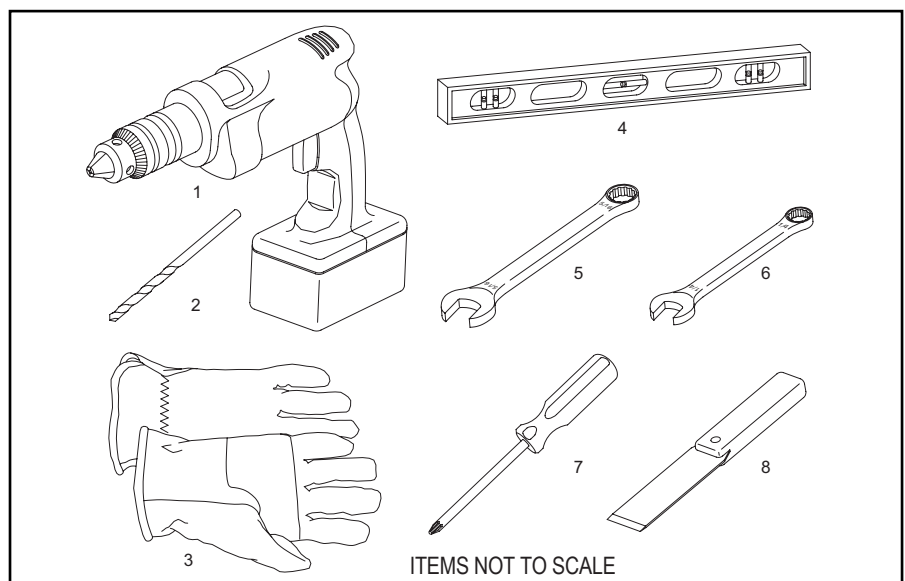

Installation Instructions for WSE Sleeve continued

Installation Requirements

- STEP 1.** The WSE sleeve should be positioned so that the drain extension extends a minimum of $\frac{9}{16}$ " beyond the outside wall (see Figure 48).
- STEP 2.** The WSE sleeve must extend a minimum of $\frac{7}{8}$ " beyond the inside wall.
- STEP 3.** The WSE sleeve must be installed level side to side.
- STEP 4.** The WSE sleeve must also be installed with a downward tilt toward the outside of the building. If a level is placed so that it rests on the front and back unit rest as shown in Figure 49, a properly installed unit provides a $\frac{3}{8}$ " slope to the outside of the building.

NOTICE

Sleeve projections and leveling precautions must be observed to prevent the entry of water into the room.

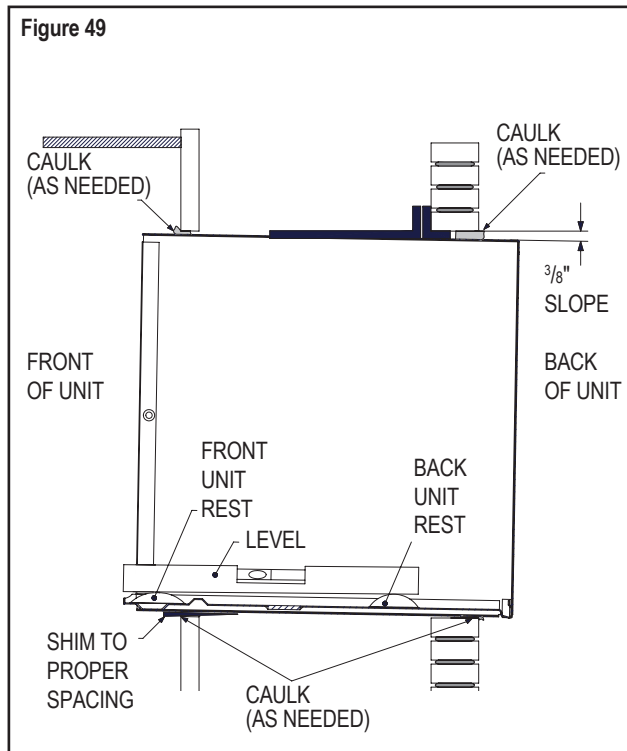

Sleeve Requirements

- STEP 1.** After unpacking the WSE sleeve from the carton, remove the indoor weather panel. Place the WSE sleeve in the wall opening following the instructions given in the Installation Requirements. Attach the sleeve to the inside wall by driving two #12A x 2" screws in each side of the sleeve (see Figure 50). Shim at the top of the sleeve, midway between the sides. Drive one #12A x 2" screw in the top of the sleeve. If the wall opening is not framed with wood, use expansion anchor bolts or molly (toggle) bolts (not provided).
- STEP 2.** Once the sleeve has been installed, check the level again to be sure the $\frac{3}{8}$ " downward slope is maintained.
- NOTE:** If necessary, apply shims below the chassis and inside the sleeve front unit rest, to ensure a $\frac{3}{8}$ " downward slope front to back.
- STEP 3.** Caulk the perimeter of the entire opening on the inside and the outside between the sleeve and the wall.
- STEP 4.** The indoor weather panel removed in Step 1 above must be remounted back in place if masonry work is to be done and/or if the "WallMaster" chassis is to be installed at a later date.

How to cover inner weather panel holes

Two beige plugs are included in the plastic bag taped to the WallMaster chassis. These plugs may be used to cover the two holes left after removing the indoor weather panel.

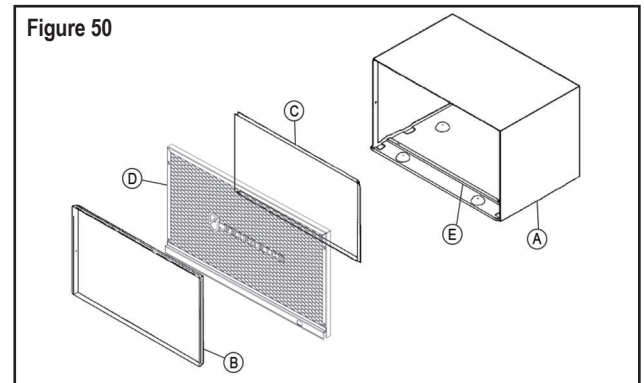

A	WSE	SLEEVE
B	61603200	INDOOR WEATHER PANEL (METAL)
C	61603304	OUTDOOR WEATHER PANEL (PAINTED METAL)
D	61603012	ASSY GRILLE WSE SLEEVE
E	61578101	GASKET (ATTACHED TO SLEEVE)

WallMaster Chassis Installation Instructions

for WCT, WET and WHT models

Condensate Removal

If you desire to drain condensate from the basepan during unit operation, this unit is provided with a drain nipple that can be attached to the basepan. You must provide a $\frac{3}{8}$ " outside diameter thin-wall plastic or copper tube which will attach to the drain nipple.

Follow the instructions below:

- STEP 1.** Find the drain rubber plug on the rear of the basepan and remove it (see Figure 52).
- STEP 2.** Remove the knockout in the lower right side of the rear grille. Slide the chassis into the WSE SLEEVE so that the drain nipple extends through the knockout.
- STEP 3.** Slide the tubing over the drain nipple. If the chassis must be removed from the sleeve for service, remove the clamped drain hose before sliding the chassis out of the sleeve.

⚠ WARNING	
	MOVING OBJECT HAZARD Replace all panels before operating your air conditioner. Failure to do so can result in severe personal injury or death and damage to product or other property.

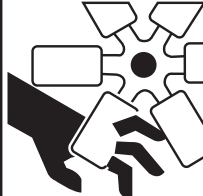
⚠ WARNING	
	MOVING PARTS HAZARDS <ul style="list-style-type: none">• Do not operate unit out of sleeve or with front grille removed.• Do not place hands in blower or fan blade areas. Failure to do so can result in serious injury.

Alternate Drain Kits

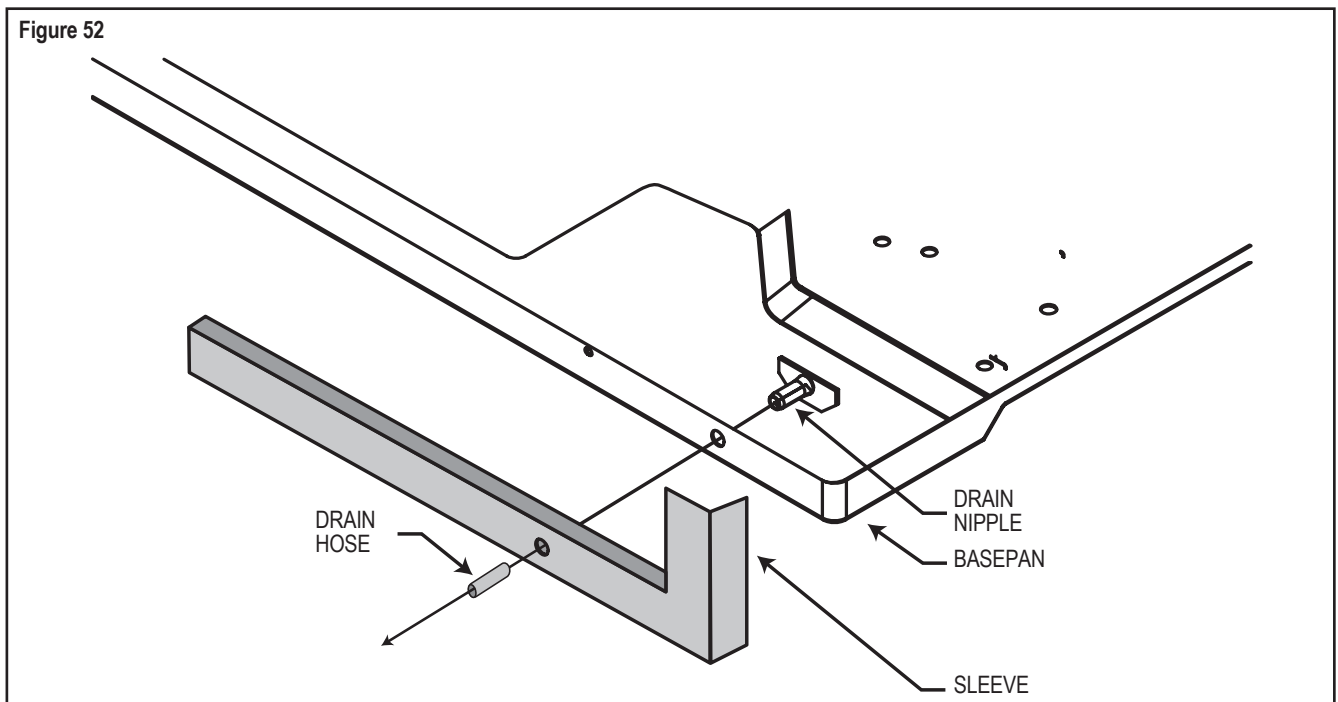

DK (Drain Kit)

In the event that the outdoor temperature drops below 37 °F, any water that remains in the chassis basepan is drained into the sleeve pan on WET and WHT models to prevent freezing. (NOTE: In the cooling mode of the WCT, WET and WHT models, condensate overflow is possible in very humid climates). For these particular instances, an optional drain kit (Accessory #DK) is available for water removal.

IDK (Drain Kit)

New construction allowing for condensate drain systems built within the walls can use the Friedrich Interior Drain Kit (Accessory #IDK). This kit is designed for installation in the bottom of the sleeve below the condensate bellows valve (heat/cool models only).

Troubleshooting Tips continued

COMPLAINT	CAUSE	SOLUTION
Unit Does Not Cool/ Heat Room Sufficiently, or Cycles On And Off Too Frequently (continued).	<ul style="list-style-type: none"> The outside temperature is below 60 °F (16 °C). 	<ul style="list-style-type: none"> Do not try to operate your air conditioner in the cooling mode when the outside temperature is below 60 °F (16 °C). The unit will not cool properly, and the unit may be damaged.
	<ul style="list-style-type: none"> The digital control is set to fan cycling mode. 	<ul style="list-style-type: none"> Since the fan does not circulate the room air continuously at this setting, the room air does not mix as well and hot (or cold) spots may result. Using the continuous fan setting is recommended to obtain optimum comfort levels.
	<ul style="list-style-type: none"> The air conditioner has insufficient cooling capacity to match the heat gain of the room. 	<ul style="list-style-type: none"> Check the cooling capacity of your unit to ensure it is properly sized for the room in which it is installed. Room air conditioners are not designed to cool multiple rooms.
	<ul style="list-style-type: none"> The air conditioner has insufficient heating capacity to match the heat loss of the room. 	<ul style="list-style-type: none"> Check the heating capacity of your unit. Air conditioners are sized to meet the cooling load, and heater size is then selected to meet the heating load. In extreme northern climates, room air conditioners may not be able to be used as a primary source of heat.
Unit Runs Too Much.	<ul style="list-style-type: none"> This may be due to an excessive heat load in the room. 	<ul style="list-style-type: none"> If there are heat producing appliances in use in the room, or if the room is heavily occupied, the unit will need to run longer to remove the additional heat.
	<ul style="list-style-type: none"> It may also be due to an improperly sized unit. 	<ul style="list-style-type: none"> Be sure to use exhaust vent fans while cooking or bathing and, if possible, try not to use heat producing appliances during the hottest part of the day.
	<ul style="list-style-type: none"> This may be normal for higher efficiency (EER) air conditioners. 	<ul style="list-style-type: none"> The use of higher efficiency components in your new air conditioner may result in the unit running longer than you feel it should. This may be more apparent, if it replaced an older, less efficient, model. The actual energy usage, however, will be significantly less when compared to older models.
	<ul style="list-style-type: none"> You may notice that the discharge air temperature of your new air conditioner may not seem as cold as you may be accustomed to from older units. This does not; however, indicate a reduction in the cooling capacity of the unit. 	<ul style="list-style-type: none"> The energy efficiency ratio (EER) and cooling capacity rating (Btu/h) listed on the unit's rating plate are both agency certified.



Friedrich Air Conditioning Co.
10001 Reunion Place, Suite 500 • San Antonio, Texas 78216
1-800-541-6645
www.friedrich.com

Printed in Mexico

93001017_00