

This Owner's Manual is provided and hosted by [Appliance Factory Parts](#).



# HESSAIRE MC61M Owner's Manual

[Shop genuine replacement parts for HESSAIRE MC61M](#)



[Find Your HESSAIRE Evaporative Cooler Parts - Select From 31 Models](#)

----- Manual continues below -----



# Mobile Evaporative Cooler

Use & Care Guide

MC37 / MC61

## INDEX

Safety Rules.....	1
Quick Start.....	2
Features.....	3
Maintenance.....	4
Cooler Parts.....	5
Warranty.....	6
Trouble Shooting.....	7

# Safety

## Safety Rules

1. Read and follow all instructions, cautions, and warnings. Failure to do so could result in personal injury, death or property damage.
2. Unit must be in the **OFF** position and **UNPLUGGED** from power receptacle before performing any maintenance.
3. Make sure the electrical power source conforms to the requirement of the evaporative cooler(s) as well as local codes.
4. To reduce the risk of fire or electrical shock, do not expose electrical connections to water.
5. Do not touch electrically live components.
6. Assure that all power cords do not meet any sharp edges, hot surfaces or chemicals. Immediately replace any damaged parts.

## Key Operational Points

Your cooler must be positioned in front of an open window or door if it is to operate effectively. (see below picture)

1. Always ensure that there is another open window or door through which the air can exhaust from the room.
2. Ensure the rigid media is kept clean throughout the use of your cooler.
3. At the end of each day run your cooler on FAN ONLY for 30 minutes to dry out the rigid media.
4. Prior to putting your cooler away for winter, always:
  - a. Drain the tank and wipe clean.
  - b. Clean the rigid media.
  - c. Reassemble and run on FAN ONLY for 30 minutes to dry out the rigid media.

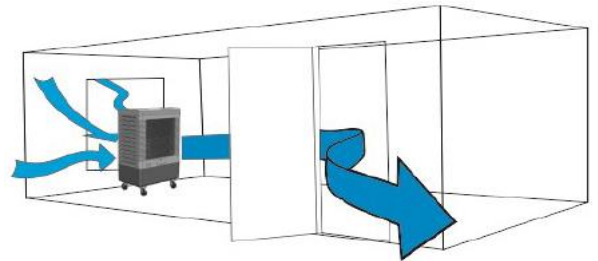

Indoor Use

**CAUTION:** BEFORE CLEANING OR SERVICING DISCONNECT POWER SUPPLY

# Quick Start

After unpacking your evaporative cooler, carefully inspect for any damage that may have occurred during transit. Inspect for loose, missing or damaged parts.

Contents: Evaporative cooler (1), Hardware Bag (1), Casters (4)

**3** Connect to any power supply

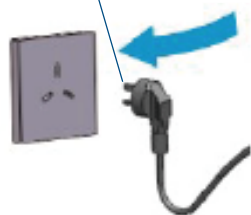





**2** Install Garden hose adapter



**5** Turn the cooler On and ENJOY

**4** Fill cooler by using bucket or hose

**1** Install Casters and Front caster with lock

			
<b>A</b> Lay the cooler down	<b>B</b> Unscrew the two screws, remove the bottom panel	<b>C</b> Taks out: Casters x4 Screws x16 Garden Hose adaptor x1	<b>D</b> Install 4 Casters

Tools / Materials Needed: Drill with #2 Phillip's bit or Phillip's head screwdriver

# Features

## MC37V / MC61V – Models Control Panel

### Switch for Fan

Has 4 positions. (Clockwise from OFF)  
OFF, LOW, MED, HI.

**Switch for Pump** - Controls the pump

**Switch for Swing** - Controls the fan oscillation

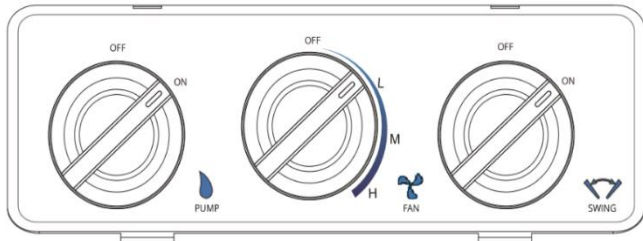

## Hose Adapter

Our convenient hose adapter allows you to have continuous water fill on your cooler.



## MC37M / MC61M – Models Control Panel

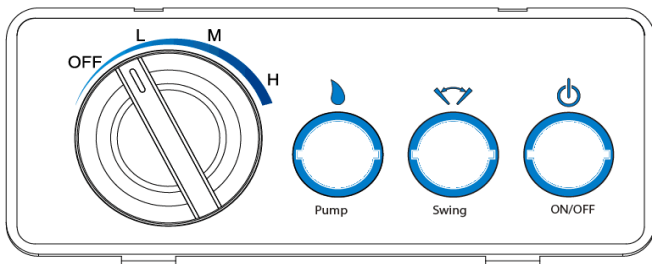

## Air Intake

These coolers have 3 media panels instead of a single panel found on most mobile coolers. 3 panels allow more air-intake area and reduce pre-rotation of the air to the prop, which translates into lower static pressure and more efficient air delivery to the prop.

### Rotary Switch for Fan

Has 4 positions. (Clockwise from OFF)  
OFF, LOW, MED, HI.

### Rocker Switch for Pump

Controls the pump

### Rocker Switch for Swing

Controls the fan Oscillation

### Rocker Switch for POWER

Main power control. When the power is turned to the "OFF" position, the other controls will not work.

# Cooler Maintenance



Use all precautions and disconnect from power source before performing any maintenance.

## Cleaning Cooler and Rigid Media Pads

The removable panel and media pad can be sprayed out on the ground to clean pad. Use light pressure when spraying pads. You can use a soft bristle brush to gently wipe away deposits. **NEVER spray pads with water while cooler is operating, and fan is running. This can cause damage to motor and will void the warranty.**

**Removal of the Back Panel (Disconnect power supply before this procedure.)**

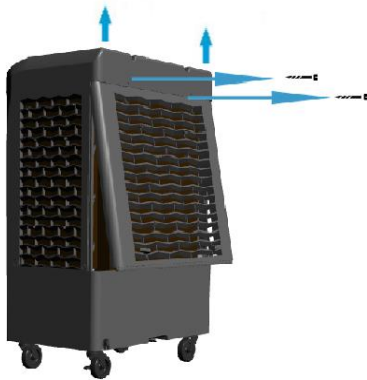

Unscrew the screws in the back panel first, then pull the back panel up.

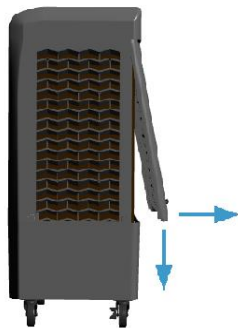

Pull out the bottom of the back panel then take it down.

## Removal and Replacement of Cooling Media

1. If your cooler includes media pins, remove by unscrewing/pulling out the disc.
2. Remove media pad. Replace with new pad.
3. Reinstall the back panel and you are ready to use the cooler again.

Go to [www.hessaire.com](http://www.hessaire.com) for replacement videos and tips for eliminating any odor.

## Draining the Cooler Tank

1. Pull or unscrew drain plug/cap from drain assembly.
2. Tip unit to ensure all water exits the unit.
3. Replace drain plug.



# Cooler Parts

Please visit [www.hessaireparts.com](http://www.hessaireparts.com) to shop for cooler parts.

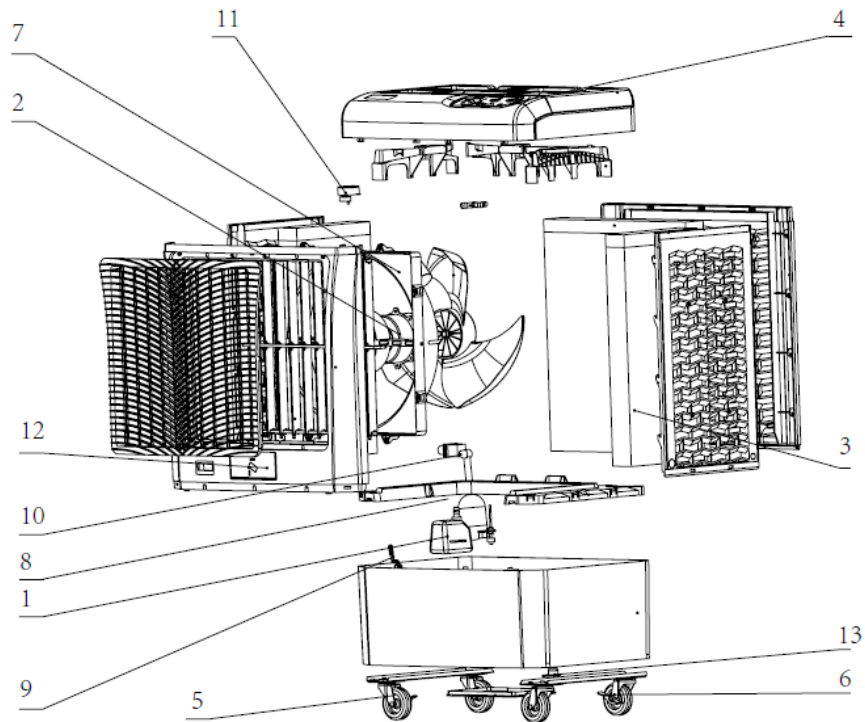

#	Parts	MC37	MC61
1	Pump	6036050	6060050
2	Motor	6037051	6061051
3	Rigid Media Set	6036053	6060053
4	Control for V model Control for M model	6038069 6037069	6038069 6037069
5	Casters	6036061	6060061
6	Casters w/lock	6036062	6060062
7	Fan Blade	6037052	6061052
8	Float Valve	6018058	6018058
9	Hose Adapter	6018088	6018088
10	Water Level Float	6037059	6037059
11	Oscillator Motor	6037057	6037057
12	Water Fill Door	6037076	6037076
13	Drain Plug	6017081	6017081

# Warranty Policy

---

## Hessaire Products Inc. Manufacturing Warranty EVAPORATIVE COOLER

---

Each new cooler is warranted to be free from defects in material or workmanship for one full year from the date of original purchase. If a component is found to be defective in this one-year period, it will be repaired or replaced with a new or refurbished product at the option of the factory.

### What is not covered by the warranty

---

1. Malfunctions resulting from misuse, negligence, alteration or lack of necessary maintenance.
2. Loss of time, inconvenience, use of product or other consequential damages due to defects.
3. Return transportation costs. All return transportation costs are the responsibility of the purchaser.
4. We do not provide maintenance personnel.

## Damaged Shipments

---

Hessaire is not responsible for damaged shipments or shortages resulting from carrier mishandling. Notify your carrier's office immediately to file a claim. Keep damaged goods and containers for inspection until advised by the carrier as to disposal.

## Returns

---

All items must be returned with all original parts and packaging. Additional charges may apply for any missing or damaged parts.

The customer must re-package and ship their item(s) back to the manufacturer at their own expense.

No freight cost/shipping cost will be re-funded to the customer.

The customer needs to provide us with the tracking number of the shipment.

Upon receipt of the product, including original parts and packaging, we may issue a full refund for the product or may repair or replace the item with a new or refurbished product.

If our returns department finds that the item is not defective, you may be responsible for additional shipping costs as well as a 10-30% re-stocking fee.



11550 US Hwy 278 E  
Holly Pond, AL, 35083  
Phone: (256)734-3003  
Fax: (256)734-3201  
[www.Hessaire.com](http://www.Hessaire.com)

# Trouble Shooting

Problem	Cause/Remedy
1. Cooler fails to work at all	<p>1.1 Check that the unit is plugged properly.</p> <p>1.2 Check the POWER switch, push it to "ON".</p> <p>1.3 The TIMER switch is "OFF", turn it to "ON".</p> <p>1.4 Make sure cooler is not plugged into a tripped GFIC outlet. If so, reset GFIC or move to non GFIC outlet.</p>
2. Cooler does not pump	<p>2.1 Pump is not activated. Push the PUMP switch to "ON".</p> <p>2.2 Water level is low. Fill with water and make sure pump is activated.</p> <p>2.3 Be sure the pump and pump hose are clear of debris.</p> <p>2.4 Pump may be defective. Replace pump. ***</p>
3a. Fan does not operate	<p>3.1 Check that unit is plugged properly.</p> <p>3.2 Check the POWER switch, push it to "ON".</p> <p>3.3 If connected to a GFIC outlet, check if it is tripped.</p> <p>3.4 Troubleshoot rotary switch. ***</p>
3b. Fan runs slow at start up	<p>3b.1 Replace motor capacitor. ***</p>
4. Louver does not operate	<p>4.1 Louver does not move. Put swing switch position to "ON".</p> <p>4.2 Check Oscillator motor for proper placement and operation.</p>
5. Water leakage	<p>5.1 Check the cap of the drain assembly, make sure it tightened.</p> <p>5.2 Inspect tank for cracks or breakage.</p> <p>5.3 Make sure cooler is level.</p> <p>5.4 Check media pads for buildup allowing water out on outside of pad frame -- change media if needed.</p> <p>5.5 If water is coming out fan, check for leaks in water distribution hoses and/or leaks at hose connections to spreaders,</p> <p>5.6 Be sure there is at least 4 inches of space for rear panel free from wall or other obstruction. This could make the side panels release water to airstream due to increased air velocity through the sides.</p> <p>5.7 Spreaders may have scale buildup allowing water to pool and spill over into airstream---Clean spreaders.</p>
6. Float Valve	<p>6.1 If water levels are too high/low, adjust the wing nut on the valve.</p> <p>6.2 If there is a leak, check for cracks. Purchase new valve at <a href="http://www.hessaireparts.com">www.hessaireparts.com</a></p>

\*\*\* - See instructional videos for repairs and replacements at [www.hessaire.com](http://www.hessaire.com) under the Media tab