

This Owner's Manual is provided and hosted by [Appliance Factory Parts](#).



HESSAIRE MC18V Owner's Manual

[Shop genuine replacement parts for HESSAIRE MC18V](#)



[Find Your HESSAIRE Evaporative Cooler Parts - Select From 31 Models](#)

----- Manual continues below -----

Hessaire Warranty

Each new cooler is warranted to be free from defects in material or workmanship for one full year from the date of original purchase. If a component(s) is found to be defective within this period, the defective part will be provided free of charge. Replacement parts are available through authorized dealers or online. Copy of proof of purchase and serial label number will be needed for all warranty claims.

What is not covered:

Malfunctions resulting from misuse, negligence, alteration or lack of necessary maintenance.

Loss of time, inconvenience, use of product or other consequential damages due to defects.

Return transportation costs. All return costs are the responsibility of the purchaser.

Hessaire does not cover labor costs associated with troubleshooting or cooler repairs regardless if the product is under warranty or not.

Damaged Shipments:

Hessaire is not responsible for damaged shipments or shortages resulting from carrier mishandling. Notify your carrier's office immediately to file a freight claim in the event of damage. Keep damaged product for inspection until advised by carrier as to disposal.

Please DO NOT return your cooler to Hessaire. Upon authorization, any returns should be sent directly to the distributor/store where purchased.

Instructional videos and other helpful parts replacement information is available on hessaire.com.

Visit hessaire.com for warranty claim forms.

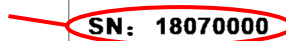
Serial Number
Location On Label: 

(label on back side of cooler bottom center)

Mobile Evaporative Cooler
Model-MXXX 110 Volts AC 60Hz XX Amps

SN: 18070000



8 18 0 15 XXXXXX



EN7



Mobile Evaporative Cooler

1300 CFM

Use & Care Guide

MC18

(color will vary by model)

INDEX

Safety Rules.....	1
Quick Start.....	2
Features.....	3
Maintenance.....	4
Troubleshooting....	5
Cooler Parts.....	6
Warranty.....	7



General Safety Precautions



Read and follow all instructions, cautions and warnings. Failure to do so could result in personal injury, death or property damage.

Unit must be in **OFF** position and **UNPLUGGED** from power receptacle before performing any maintenance / service or before **REMOVING** access panels.

Make sure the electrical power source conforms to the requirement of the evaporative cooler as well as local codes.

To reduce risk of fire or electrical shock, do not expose electrical connections to water.

Do not touch electrically live components.

Ensure all power cords do not touch sharp edges, hot surfaces or chemicals. Immediately replace damaged parts.

Never leave unit unattended.

Continuous fill not to be used indoors or unattended.

Operation Tips

Hessaire coolers are highly recommended for outdoor use. If used indoors, position cooler in front of window or open door for fresh intake air. Ensure there is an open door or window through which the air can exhaust from the room.

Clean media pads and tank frequently.

When shutting down unit, run without pump for 30 minutes to properly dry media pads.

Prior to long term storage:
Drain tank and wipe clean
Dry and clean rigid media pads

Indoor Use: Do Not Use
Garden Hose Attachment /
Continuous Fill Indoors.

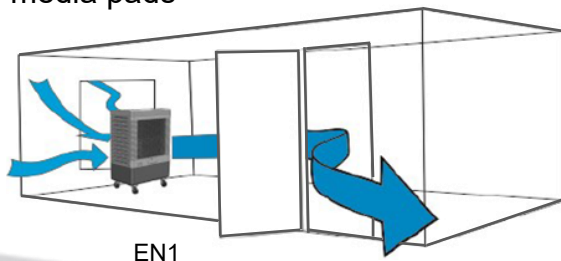

EN1

Cooler Parts

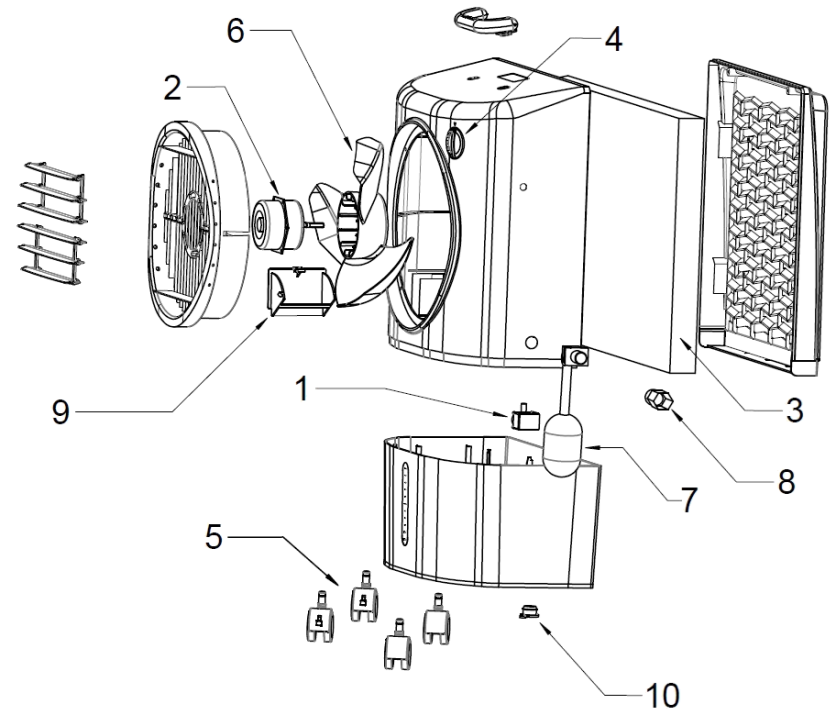

#	Parts	MC18
1	Pump	6017050
2	Motor	6017051
3	Rigid Media Panel	CP150
4	Control Knob & Switch	6017069
5	Caster Set (4 pcs)	6176100
6	Fan Blade	6017052
7	Float Valve Kit: 65 PSI Rated (float valve, hose adapter)	6018058
8	Brass Hose Adapter	6018088
9	Manual Fill Door	6017076
10	Drain Plug	6017081

EN6

COOL AIR ANYWHERE



Troubleshooting

Problem	Cause / Remedy
Cooler won't turn on	Ensure unit is plugged in and switched on. Receptacle breaker may need to be reset. If unit is equipped with a GFCI plug, reset. If unit has a timer, ensure it is off. Wires to switch may be disconnected. Reconnect. Control switch may need to be replaced.
Fan will not operate	Ensure fan function is on. Make sure nothing is obstructing fan blade. Fan motor may need to be replaced. Control switch may need to be replaced. Slow running - may need capacitor replaced.
Cooler does not pump	Ensure pump switch is turned on. Make sure water level is not low. Add water. Make sure hoses are connected and free of debris. Pump may need to be replaced. Control switch may need to be replaced.
Water leakage	Make sure drain plug is securely in place. Make sure cooler is level. Inspect tank for cracks. Check media pads for water running on outside of unit. Check for leaks in water distribution hose connections. Check spreaders for build up causing spill over of water into the airstream.
Water level high or low	Adjust nut on float valve. Float valve may need to be replaced.

CAUTION: Max. water pressure to unit: **65 psi**. Must use regulator for water pressure exceeding 65 psi.

EN5

Inspection

After unpacking your cooler, carefully inspect for any damage that may have occurred during transit. Inspect for loose, missing or damaged parts. *Note: wheels & hose adapter are located on top of cooler upon opening box.*

Contents: Evaporative Cooler (1), Hose Adapter (1), Caster Wheels (4).

Visit Hessaire.com to request replacement parts if any of these items are missing.

Quick Start

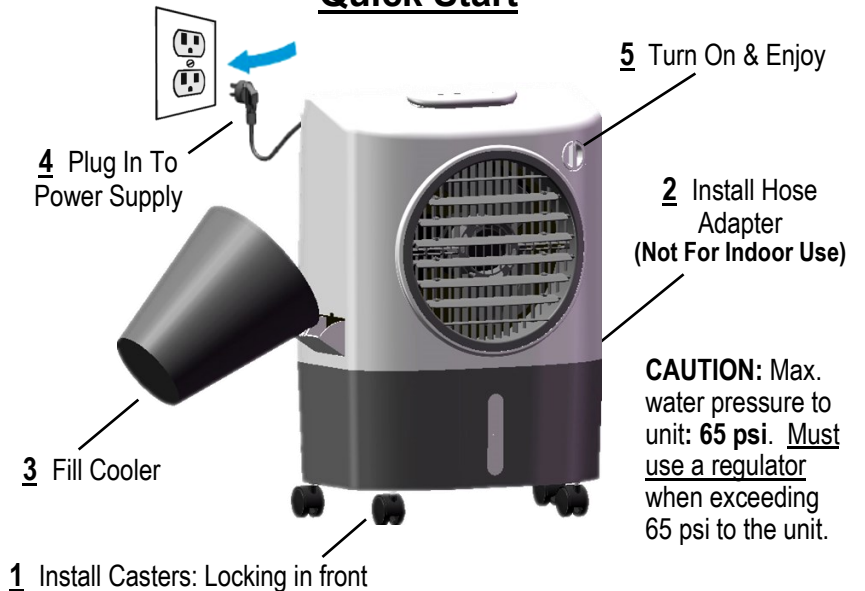

Note: Media pads may have a slight odor upon initial start up but will go away with continued use.

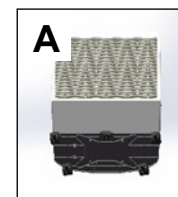

Lay Cooler Down

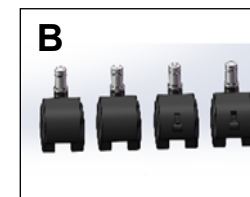

Gather Casters, Push In To Install

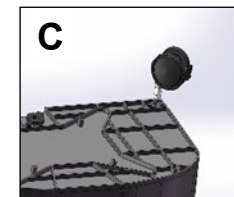

EN2

COOL AIR ANYWHERE



Features

Control Functions For MC18

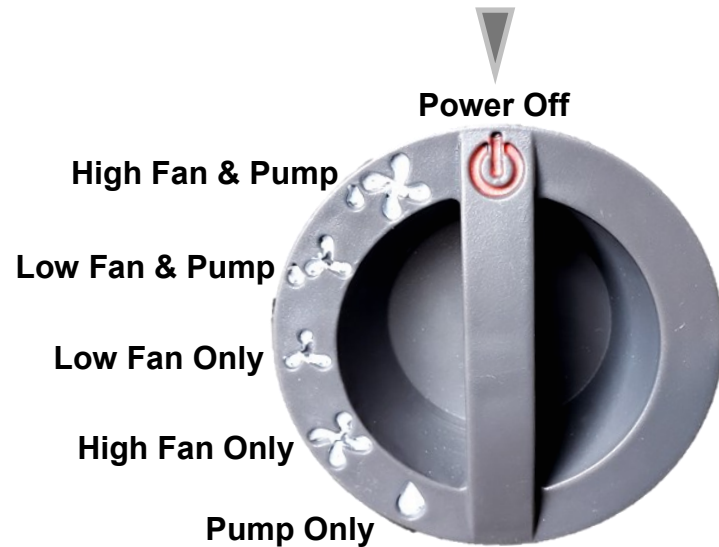

Convenient Carry Handle



EN3

Continuous Fill Option
(not for indoor use)



Manual Fill Option

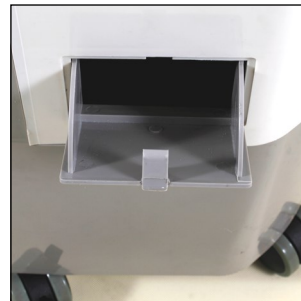

Maintenance

⚠ WARNING Disconnect from power source before attempting any maintenance or routine service. NEVER remove any access panels while cooler is in operation. Failure to do so could lead to **SERIOUS INJURY**.

Cleaning Cooler & Rigid Media Pads:

The removable panel(s) & pads can be gently sprayed off to remove build up. A soft bristle brush can also be used.

NEVER spray pads with water while cooler is in operation. Damage can occur to the motor and will void the warranty.

Note: Vinegar is recommended for cleaning of cooler and can be periodically cycled through during normal use.

Removal Of Back Panel:

Disconnect power supply. Remove the two phillips screws from the upper back side of cooler.

Pull out top of back panel, lift out.

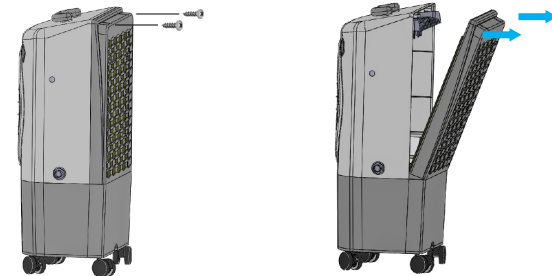

Removal Of Rigid Media:

Once back is removed, the media pads will be accessible. *Note: some pads may be held in place with pins (media keepers) which will need to be removed to free up the pads.*

Storage:

Drain tank and wipe dry. Plug is located on bottom of cooler. Ensure pads are dry by running fan without pump for at least 30 minutes.

Visit Hessaire.com for additional maintenance tips and service videos.

EN4