

This Owner's Manual is provided and hosted by [Appliance Factory Parts](#).



HESSAIRE RM6808S Owner's Manual

[Shop genuine replacement parts for HESSAIRE
RM6808S](#)



[Find Your HESSAIRE Evaporative Cooler Parts - Select From 31 Models](#)

----- Manual continues below -----

Please read and save these instructions. Read carefully before attempting to assemble, install, operate or maintain the product described. Protect yourself and others by observing all safety information. Failure to comply with instructions could result in personal injury and/or property damage! REtain instructions for future reference.

Hessaire® Evaporative Coolers

Description

The Hessaire® Evaporative Cooler is a natural way to condition the atmosphere. It cools by combining water evaporation with air movement, through carefully designed and manufactured equipment, providing maximum efficiency and safety. This air conditioning system, in addition to being economical, gives more benefits than other air conditioning systems for homes and businesses. The system does not use refrigerants or compressors; it cools by simply moving air through moist filters. Air temperature drops when a liquid, in this case water, transforms into gas. Humidity is not perceived, since the air in the room is renewed approximately every two minutes, providing a comfortable cooling effect. Continuous air circulation is a vital aspect of the cooling process in this equipment, and gives it a distinct advantage over air conditioning by refrigeration.

Unpacking

Handle product carefully and check the packing list to account for all items. Visually inspect for shipping damage. If damaged, immediately file a claim with the carrier.

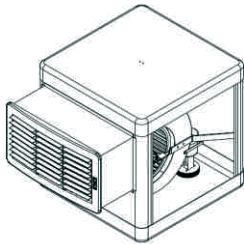

Window Unit
W28 / W38 / W48

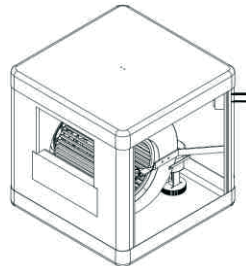

Ducted Unit-Side Discharge
A38S / A48S / A68S

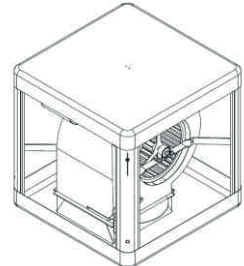

Ducted Unit-Side Discharge
A38D / A48D / A68D

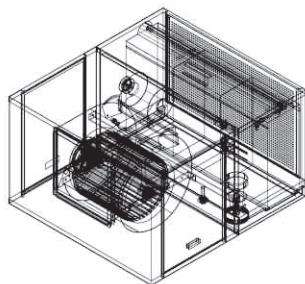

**Ducted Unit-Side Discharge
(Rigid Media)**
RM4808S / RM4812S
RM6808S / RM6812S
RM3808S

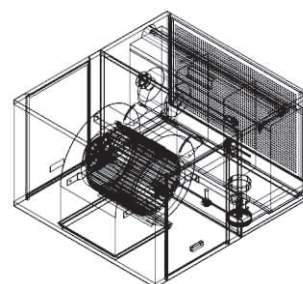

**Ducted Unit-Side Discharge
(Rigid Media)**
RM4808D / RM4812D
RM6808D / RM6812D
RM3808D

Note: Filters not shown (wet media)

Hessaire® Evaporative Coolers

General Safety Information

1. Read all instructions before operating, installing or fixing the evaporative air cooler.
2. This product operates at 110-120V AC, 60 Hz only
3. Do not use with a damaged cord or plug, and keep the cord away from heated surfaces.

⚠ WARNING *If the power supply cord is damaged, it must be replaced by a qualified person in order to avoid a hazard.*

4. Do not insert any foreign objects into the air inlet or outlet, body injury or property damage may occur.
5. Do not operate this product near an open fire, it may ignite and cause fire, resulting in body injury or property damage.
6. Do not operate in areas where gasoline, paint or other flammable liquids are used or stored.

⚠ WARNING *Prior to cleaning or other maintenance, the air cooler must be unplugged.*

7. Always unplug the power cord from receptacle when the air cooler is not in use, before cleaning, replacing parts, or before moving to another location.
8. Do not plug the cord into electric outlet with wet hands, an electric shock may result.
9. Never attempt to disassemble or alter the product in any way not instructed by this manual. Shock, fire, or body injury may occur.
10. Use only on GFCI protected receptacle.
11. Do not use this appliance in the immediate surrounds of a bath, a shower or a swimming pool or other liquids.

⚠ WARNING *To reduce the risk of fire or electric shock, do not use this fan with any solid-state speed control device.*

Installation

Window Models: W48, W38 and W28

NOTE: To be installed by a licensed professional technician.

1. Take the measurements of the neck and open the wall or window accordingly.
2. Remove the front grill from the unit by unscrewing the bolts.

NOTE: Be careful not to unplug the front switches.

3. Install the unit through the wall or window opening.
4. Secure the unit to the wall or window and support the weight of the unit if above the ground.

NOTE: The weight of the unit is increased when water is added.

5. Level unit horizontally.
6. Install float and drain valve (see pages 4 & 5).
7. Check all water connections.
8. Connect unit to 110-120V GFCI receptacle.

Installation

Portable models M28, M38

1. Set your equipment in a well ventilated area
2. Adjust the breaks of the wheels to avoid movement of your equipment
3. Install the float valve and overflow tube (see pages 4 & 5)
4. Plug the water hose with the float valve, or add water inside the unit removing one of the walls (filters, taking care of not wet the motor), and set it back.
5. Connect the equipment (plug) to a GFCI receptacle of 110-120V



COOL AIR ANYWHERE

Hessaire® Evaporative Coolers

Ducted Models: A68S/D, A48S/D, A38S/D and RM4808S/D, RM6808S/D, RM4812S/D, RM6812S/D RM3808S/D

NOTE: To be installed by a licensed professional technician.

⚠ WARNING *Disconnect all power to the evaporative air cooler*

1. Install evaporative air cooler in a well ventilated area. A common equation for air flow is for every open area of 1 x 1 feet there should be 500 CFM of injected air.
2. Assure the mounting surface is able to bear the weight of the evaporative air cooler.

NOTE: The weight of the unit is increased when water is added.

3. Confirm the electrical supply is adequate for the requirements of the unit.

⚠ WARNING *The evaporative air cooler must be installed according to all national and local electrical codes. The installation must be performed by a qualified technician.*

4. Assure that the mounting surface is level in all directions.

Float Valve Assembly

The following parts are included:

Float Valve
O-Ring
Nut
1/4" hose oppressor
Barrel Nut

1. Remove the float valve and parts (listed above) from inside the unit.
2. Push the plastic o-ring onto the threaded shaft of the float valve until snug against the back.
3. Pass the shaft of the float valve through the pre-drilled hole in the unit.

4. Secure with the plastic nut.
5. Insert 1/4" water hose into the barrel nut.
6. Insert the 1/4" plastic hose oppressor.
7. Countersink the hose edge that will be placed up against the float valve shaft.
8. Place the hose edge to the float valve shaft and tighten with the barrel nut.
9. Check for leaks.
10. Adjust the water level requirement for your unit.

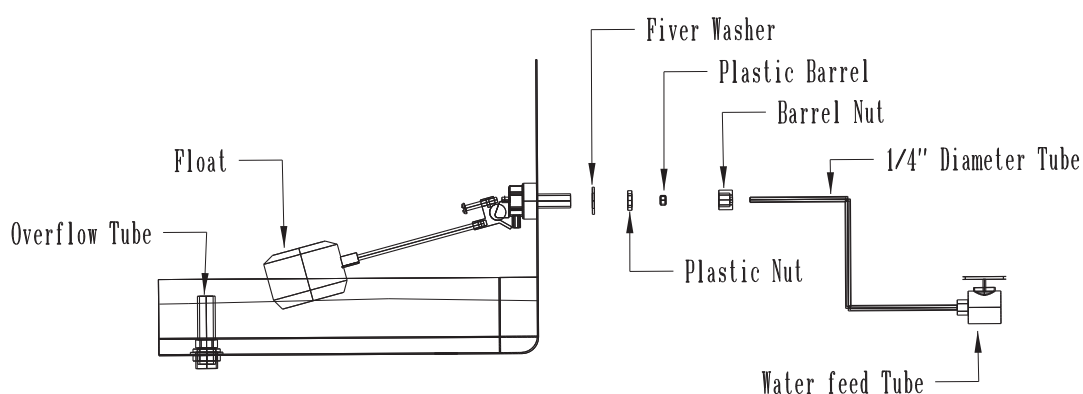

Hessaire® Evaporative Coolers

Overflow Tube Assembly

1. Place the rubber washer on the bottom tray aligned with the drain hole.
2. Push the plastic drain piece through the rubber washer and out the drain hole.
3. Screw the overflow tube into the plastic drain piece.
4. Tighten to the unit with the plastic nut from the bottom of the unit.
5. Check for water leakage.

Electrical Connection

⚠ WARNING *All electrical connections must comply with federal and local safety regulations and be performed by a qualified professional technician.*

Confirm before initial startup.

1. Cabinet is level.
2. Blower spins freely.
3. Electrical specifications meet the amperage of the unit.
4. Water supply is stable and no leaks.

Connect the unit to a 110-120~ +/- 10% 60Hz current (wiring diagram, page 9). The power supply for the cooler should be connected directly to the main switch box. Make sure that the power switcher are in the off position before operating your cooler.

⚠ WARNING *If the power supply cord is damaged, it must be replaced by a qualified person in order to avoid a hazard.*

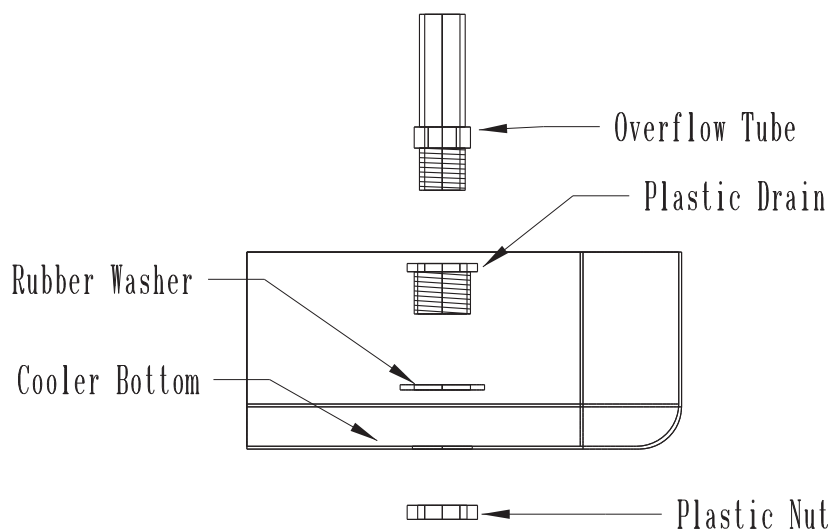

Hessaire® Evaporative Coolers

Maintenance

Maintenance is important for your cooler to have an effective and long service life. To avoid unnecessary part replacements, keep your unit in good condition. Do not add cleaners, additives or scents to the water, it may reduce the life of your equipment. Do not change the size of the pulleys, it may overload the motor and “burn out” the unit.

Beginning of Season

1. Turn off power to the unit.
2. Change the aspen or Celdek® evaporative cool pad.

NOTE: Be sure the Celdek® cool pad arrows are in the same direction as the air flow.

3. Clean the tray, equipment and filters. (See Unit Cleaning)
4. Check the belt condition and tension. (See drawing page 7)
5. Lubricate bearings, as necessary. (Lithium base oil)
6. Open water valve.
7. Confirm the water distribution is working properly.
8. Adjust the water float valve if needed.
9. Start the unit.

Middle of Season

1. Change aspen or RIGID MEDIA evaporative cool pad if neces-

End of Season

1. Turn off power to the unit.
2. Close the water valve.
3. Remove V-belt.
4. Drain and dry the tray.
5. Lubricate bearings.
6. Cover the unit.

UNIT CLEANING

For units: Window, Ducted Aspen and Mobile Units.

1. Be sure to turn off the power supply before performing maintenance.
2. Remove the side and back walls of the cabinet.
3. Completely drain the cabinet by removing the drain from the base.
4. Using a brush with soft plastic bristles, clean the water tank by removing the dust and accumulated mineral salts (only use water to clean the tank).
5. Put the drain back into its original position. Make sure there are no leaks.

6. If you are not going to use your unit for more than 30 days, turn off the main water and power supply.

For units: Rigid Media Units

1. Turn off power to the unit.
2. Remove the bolts and open the cover 180°
3. Remove the rear plate.
4. Carefully remove the pieces.
5. Remove the Rigid Media toward the rear plate and put aside to dry.
6. Clean the Rigid Media with a smooth, plastic brush after the pad is dry.
7. Clean the bottom tray.
8. Confirm the float valve is installed properly.
9. Re-install the Rigid Media by following the arrows on the pad.
10. Re-install the pieces into the Rigid Media pad.
11. Re-install the rear plate and the cover.



COOL AIR ANYWHERE

Hessaire[®] Evaporative Coolers

WATER PUMP

1. Turn off the power to the unit.
 2. Remove shipping lock on pump body.
 3. Remove the bottom base plate to clean pump cavity when clogged.
 4. Clean pump filter when clogged by using soft bristle brush to remove accumulated dust and scaling.
 5. Re-install base plate by following sequence numbers on the bottom of the plate.
 6. Remove water pump from cooler during the winter and store in a dry place.
2. Remove the dirty filters.
 3. Clean the wall body and the upper channel. Use water and a soft bristle brush only.
 4. Place the new filters into the walls. Make sure that the filters are well moistened before putting them into place.
 5. Place the supports into their original position once maintenance has been performed.

NOTE: Never remove the screen, as removal may cause contaminants to obstruct pump.

NOTE: Never operate the unit without these parts in place. Doing this could generate an overload and damage the motor.

BELT ADJUSTMENT

The adjustable belt and pulleys are factory set. Any alteration to the air flow system should be done by an authorized technician. Before any adjustment is made, unplug the cooling system.

the efficient operation of the unit. Do not adjust the belt tension by changing the pulleys diameter. Adjust the brackets that hold the motor to the motor base only. Due to wear and use, the belt tends to loosen, therefore, check for proper tension during maintenance.

To adjust the belt tension, loosen the screws on the motor brackets (use a 7/16 inch or an adjustable wrench). Once loosened the motor can then be repositioned to apply more tension to the belt. Belt tension should be adjusted to allow for 1.2 cm (1/2") to 2 cm (3/4") of flexing on each side of pulley. Once the required belt tension is reached, retighten set screws on the bracket. Align the belt in vertical position, and check the amperage of the motor.

CHANGING THE FILTER/ WET MEDIA (ASPEN / RIGID MEDIA)

1. Using pliers, unbend the points of the supports and remove them from the wall.

The appropriate belt tension and alignment is an important factor for

PULLEY ALIGNMENT

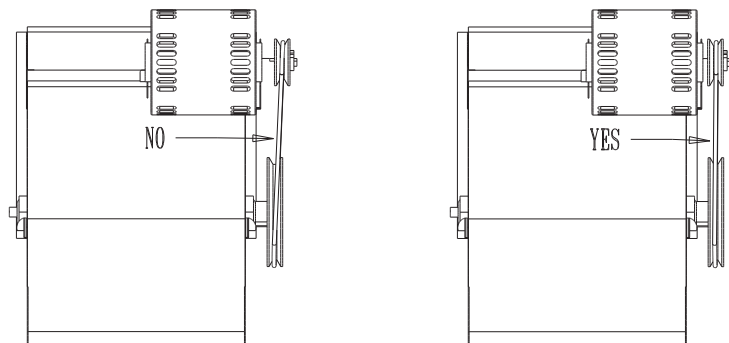

Hessaire[®] Evaporative Coolers

PULLEY ADJUSTMENT

Incorrect pulley adjustment and alignment will affect performance by reducing airflow raising amperage or causing motor to overheat.

⚠ WARNING Before make any adjustments de-energize your equipment to avoid personal risks.

To adjust pulleys loosen the set screw and align the motor pulley with the turbine pulley vertically by moving outwards or inwards on the shaft of the motor. A straight edge should be used when aligning pulleys. After adjustment retighten set screws. Turn the turbine pulley manually to make

sure it misses the turbine box and that the motor pulley does not make contact with the motor.

Motor maintenance

⚠ WARNING Always de-energize your cooler before working near or in the motor.

1. The motor can require periodical maintenance to avoid overheating due to dust accumulation on the windings and frame.
2. Lubricate the motor annually after first year of use to extend bearings life.

3. Add 15 to 20 oil drops for electric motor or SAE grade 10, and turn the shaft.

Lubricating bearings

⚠ WARNING Always de-energize your cooler before any maintenance.

1. Add 6 drops of lithium oil or grease with lithium base.
2. Do this maintenance two times per year.

PULLEY ADJUSTMENT

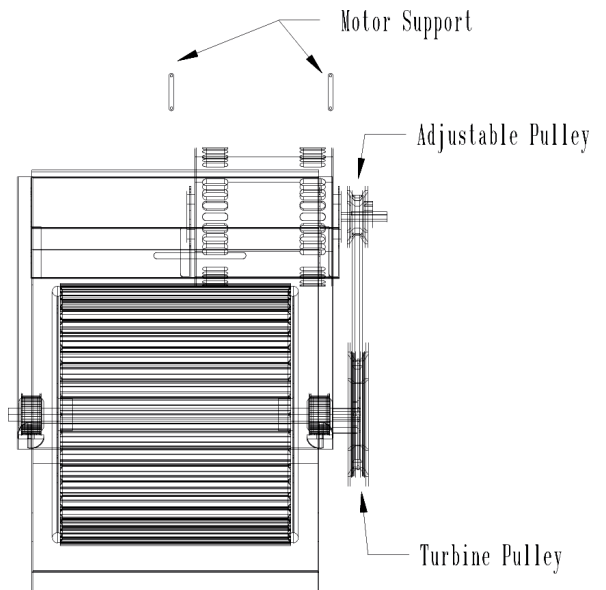
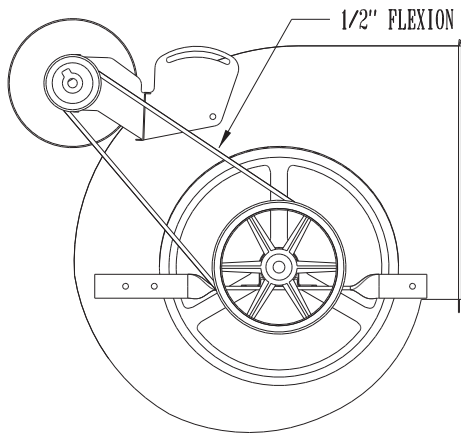

Hessaire® Evaporative Coolers

Electrical Diagram Models W28 & M28

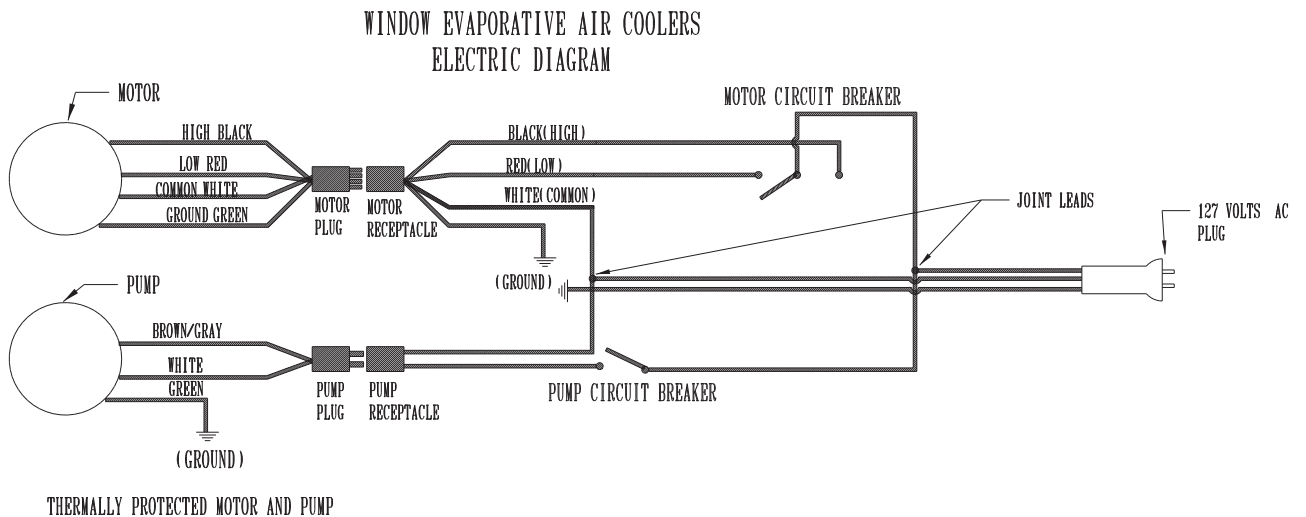

Electrical Diagram Models W48, W38 & M3

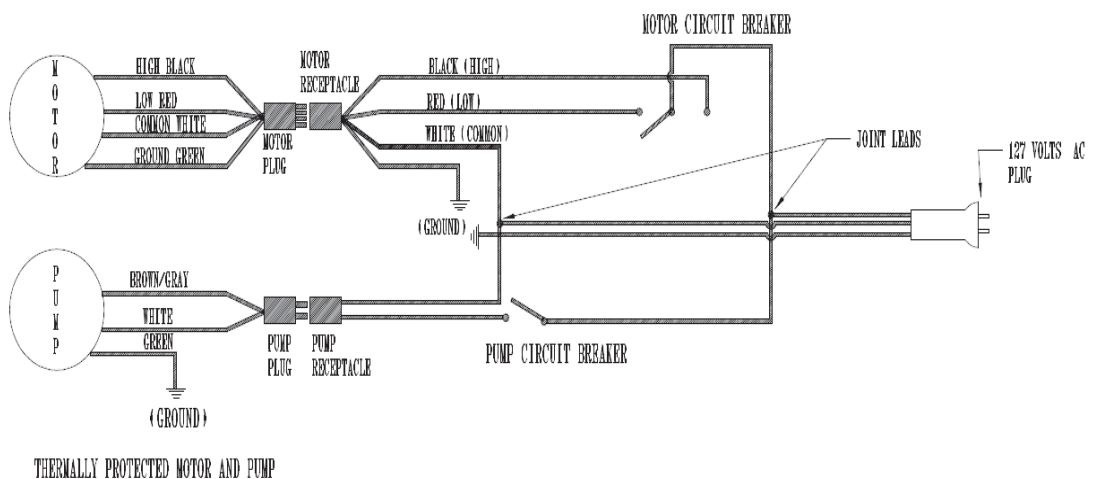

Hessaire® Evaporative Coolers

Models RM4808D, RM4812D, RM6808D, RM6812D, RM4808S, RM4812S, RM6808S, RM6812S, A38D, A48D, A68D, A38S, A48S, A68S, RM3808S/D (ducted units, side and down discharge)

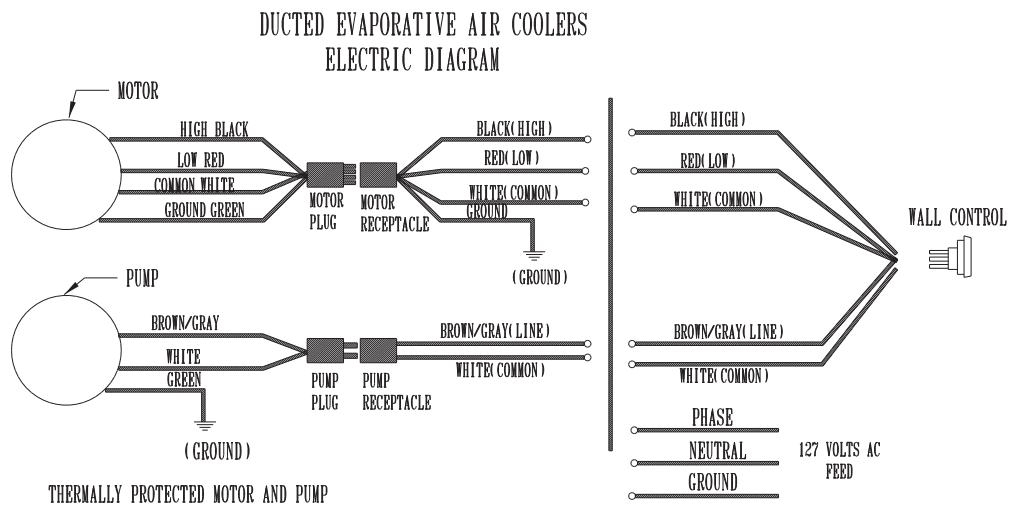

Hessaire[®] Evaporative Coolers

Symptoms	Possible Cause	Corrective Action
Unit does not start	1. Unit does not have electricity.	1. Check the electrical.
	2. Blown fuse.	2. Change the fuse.
	3. Switch is disconnected.	3. Re-connect switch.
	4. Motor is overheated.	4. Call an authorized technician.
	5. Wiring failure/ short circuit.	5. Consult with an electrician.
Insufficient Cooling/ Excessive humidity	1. Front grill is not oriented correctly.	1. Correct the orientation of the grill.
	2. Filter is not wet.	2. Check water distribution hose and pump for leaks or bends.
	3. Filter is full of dust or mineral salts.	3. Clean or change filter.
	4. Water distributor clogged.	4. Change water distributor.
	5. Water pump is not working.	5. Clean pump filters, check filter, or replace pump.
	6. Motor overload.	6. Call an authorized technician.
Motor shuts off	1. Motor shaft is forced.	1. Call an authorized technician.
	2. Tight belt.	2. Adjust belt tension.
	3. Propeller not centered.	3. Call an authorized technician.
Water leaking from unit	1. Float valve adjusted incorrectly.	1. Correct position of valve and adjust float level.
	2. Drain not tightened.	2. Tighten the drain.
Inside Noises	1. Bearings do not have sufficient oi.	1. Lubricate bearings.
	2. Propeller is not aligned.	2. Call an authorized technician.
	3. Loose pulleys	3. Adjust and tighten pulleys.
Unpleasant smells	1. Stagnant water in tank	1. Drain, wash and clean the tray.
	2. Filters are full of dust.	2. Clean or change filters.
Water leaving by the front grill	1. Filters too much wet (damp)	1. Restrict the water way to the filters, obstruct partially the internal water hose.

Hessaire® Evaporative Coolers

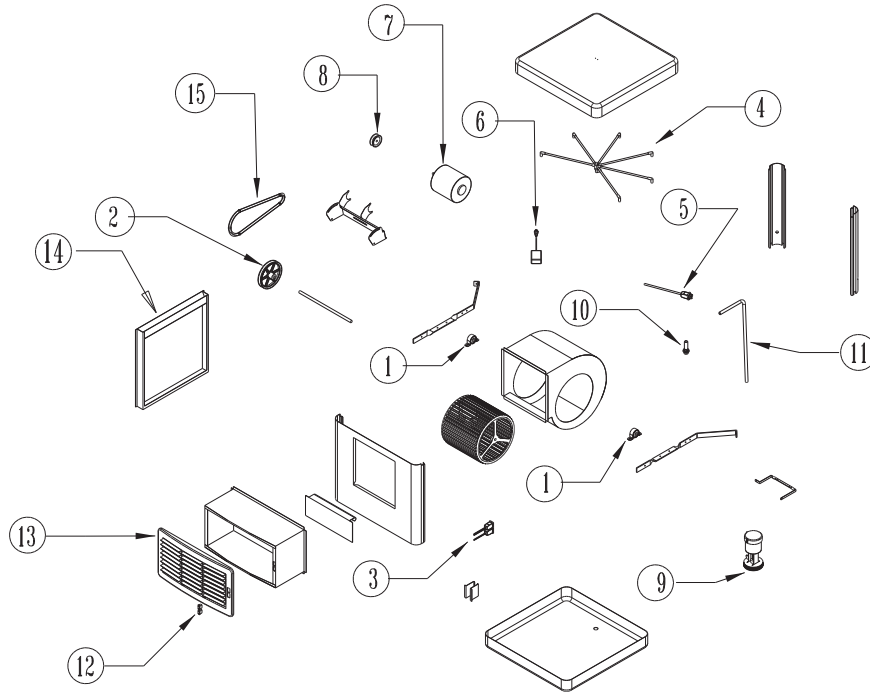

Ref No.	Description	Qty
1	Bearings	2
2	Turbine Pulley	1
3	Motor & Pump Receptacles	1
4	Water Distributor	1
5	Motor Plug	1
6	Float	1
7	Motor	1
8	Adjustable Pulley	1
9	Water Pump	1
10	Overflow Pipe	1
11	Water Hose	1
12	Motor & Pump Switches	1
13	Front Grill	1
14	Filter	1
15	V-Belt	1

Hessaire® Evaporative Coolers

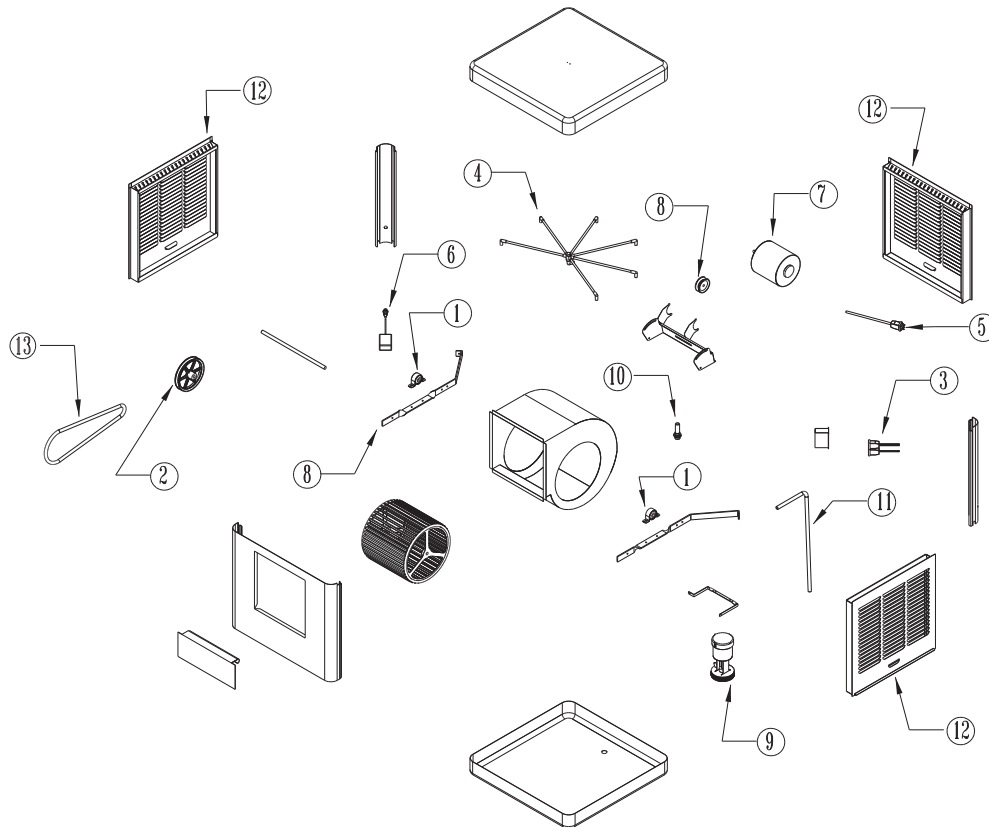

Ref No.	Description	Qty
1	Bearings	2
2	Turbine Pulley	1
3	Motor & Pump Receptacles	1
4	Water Distributor	1
5	Motor Plug	1
6	Float	1
7	Motor	1
8	Adjustable Pulley	1
9	Water Pump	1
10	Overflow Pipe	1
11	Water Hose	1
12	Filter	1
13	V-Belt	1

Hessaire® Evaporative Coolers

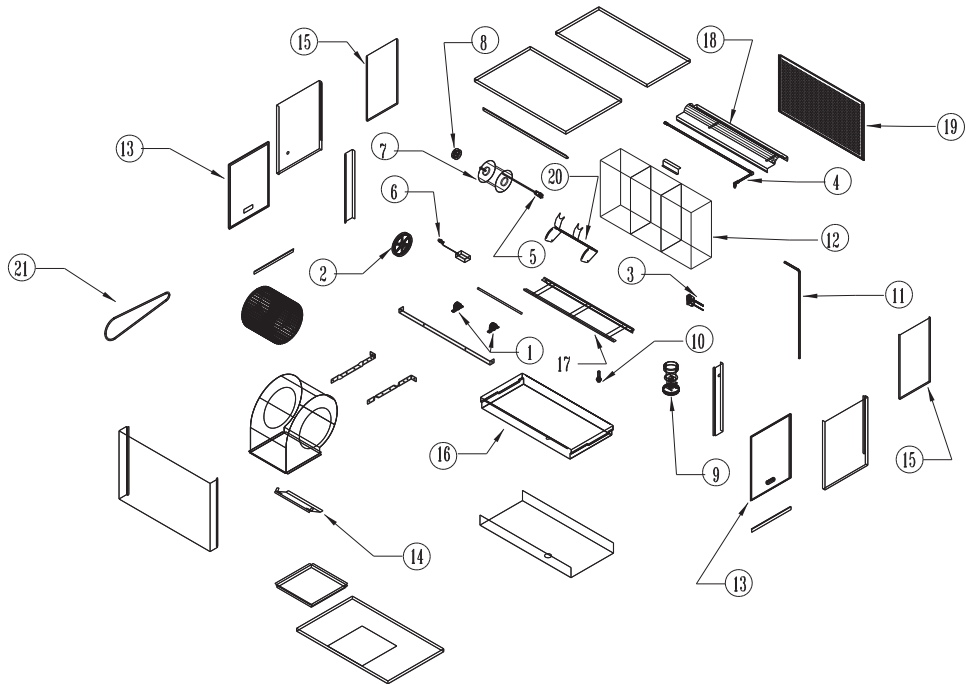

Ref No.	Description	Qty
1	Bearings	2
2	Turbine Pulley	1
3	Motor & Pump Receptacles	1
4	Water Distributor	1
5	Motor Plug	1
6	Float	1
7	Motor	1
8	Adjustable Pulley	1
9	Water Pump	1
10	Overflow Pipe	1
11	Water Hose	1
12	Celdek®	1
13	Doors	2
14	Cutter	1
15	Wet Module Sideways	2
16	Thermoformed Tray	1
17	Celdek® Base	1
18	Land Fill	1
19	Protective Mesh	1
20	Motor Base	1
21	V-Belt	1

Hessaire® Evaporative Coolers

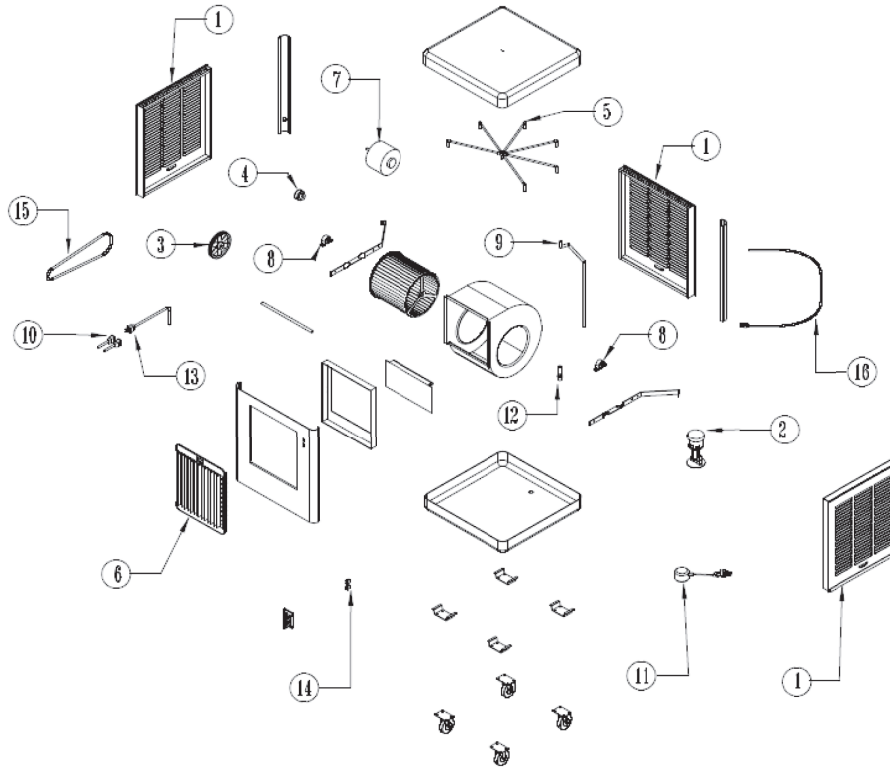

Repair Parts List for M38

Pcd Lm	Description	Qty
1	Filter	1
2	Water Pump	1
3	Turbine pulley	1
4	Motor pulley	1
5	Water Distributor	1
6	Front grill	1
7	Motor	1
8	Bearings	2
9	Water hose	1
10	Motor & pump receptacles	1
11	Float	1
12	Overflow pipe	1
13	Motor Plug	1
14	Motor & pump switches	1
15	V-belt	1

Hessaire® Evaporative Coolers

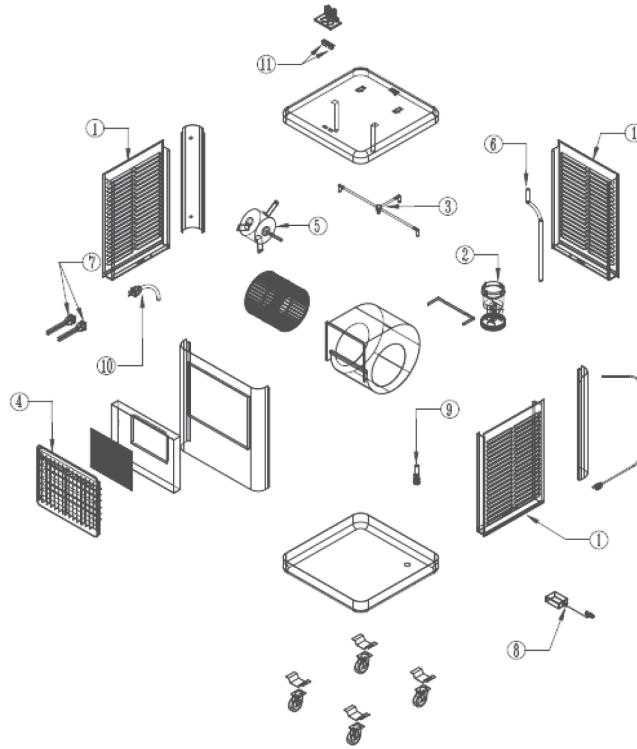

Repair Parts List for M28

Pcd Lm	Description	Qty
1	Filter	1
2	Water Pump	1
3	Water distributor	1
4	Front grill	1
5	Motor assy	1
6	Water hose	1
7	Motor & pump receptacles	1
8	Float	1
9	Overflow pipe	/
10	Motor plug	1
11	Motor & pump switches	1

Hessaire[®] Evaporative Coolers

LIMITED WARRANT-

Hessaire[®] EVAPORATIVE COOLER MODELS COVERED IN THIS MANUAL, ARE WARRANTED BY USASIA, LLC. TO THE ORIGINAL USER AGAINST DEFECTS IN WORKMANSHIP OR MATERIALS UNDER NORMAL USE FOR ONE YEAR AFTER DATE OF PURCHASE. ANY PART WHICH IS DETERMINED TO BE DEFECTIVE IN MATERIAL OR WORKSHIP AND RETURNED TO AN AUTHORIZED SERVICE LOCATION, USASIA, LLC WILL DESIGNATE REMEDY, REPAIR OR REPLACEMENT. FOR LIMITED WARRANTY CLAIM PROCEDURES, SEE "PROMPT DISPOSITION" BELOW. THIS LIMITED WARRANTY GIVES PURCHASERS SPECIFIC LEGAL RIGHTS WHICH VARY FROM JURISDICTION TO JURISDICTION.

LIMITATION OF LIABILITY. TO THE EXTENT ALLOWABLE UNDER APPLICABLE LAW, USASIA'S LIABILITY FOR CONSEQUENTIAL AND INCIDENTAL DAMAGES IS EXPRESSLY DISCLAIMED. USASIA'S LIABILITY IN ALL EVENTS IS LIMITED TO AND SHALL NOT EXCEED THE PURCHASE PRICE PAID.

WARRANTY DISCLAIMER. A DILIGENT EFFORT HAS BEEN MADE TO PROVIDE PRODUCT INFORMATION AND ILLUSTRATE THE PRODUCTS IN THIS LITERATURE ACCURATELY; HOWEVER, SUCH INFORMATION AND ILLUSTRATIONS ARE FOR THE SOLE PURPOSE OF IDENTIFICATION, AND DO NOT EXPRESS OR IMPLY A WARRANTY THAT THE PRODUCTS ARE MERCHANTABLE, OR FIT FOR A PARTICULAR PURPOSE, OR THAT THE PRODUCTS WILL NECESSARILY CONFORM TO THE ILLUSTRATIONS OR DESCRIPTIONS, EXCEPT AS PROVIDED BELOW, NO WARRANTY OR AFFIRMATION OF FACT, EXPRESSED OR IMPLIED, OTHER THAN STATED IN THE "LIMITED WARRANTY" ABOVE IS MADE OR AUTHORIZED BY USASIA.

Technical Advice and Recommendations, Disclaimer. Notwithstanding any past practice or dealings or trade custom, sales shall not include the furnishing of technical advice or assistance system design. USASIA assumes no obligations or liability on account of any unauthorized recommendations, opinions or advice as to the choice, installation or use of products.

Product Suitability. Many jurisdictions have codes and regulations governing sales, construction, installation, and/or use of products for certain purposes, which may vary from those in neighboring areas. While attempts are made to assure that Dayton products comply with such codes, USASIA cannot guarantee compliance, and cannot be responsible for how the product is installed or used. Before purchase and use of a product, review the product applications, and all applicable national and local codes and regulations, and be sure that the product, installation, and use will comply with them. Certain aspects of disclaimers are not applicable to consumer products; e.g., (a) some jurisdictions do not allow the exclusion or limitation of incidental or consequential damages, so the above limitation or exclusion may not apply to you; and (c) by law, during the period of this Limited Warranty, any implied warranties of implied merchantability or fitness for a particular purpose applicable to consumer products

Prompt Disposition. A good faith effort will be made for prompt correction or other adjustment with respect to any product which proves to be defective within limited warranty. For any product believed to be defective within limited warranty, first write or call dealer from whom the product was purchased. Dealer will give additional directions. If unable to resolve satisfactorily, write to USASIA, LLC at address below, giving dealer's name, address, date, and number of dealer's invoice, and describing the nature of the defect. Title and risk of loss pass to buyer on delivery to common carrier. If product was damaged in transit to you, file claim with carrier.