

This Owner's Manual is provided and hosted by [Appliance Factory Parts](#).



HESSAIRE DX4800 Owner's Manual

[Shop genuine replacement parts for HESSAIRE DX4800](#)



[Find Your HESSAIRE Evaporative Cooler Parts - Select From 31 Models](#)

----- Manual continues below -----

**DIRECT DRIVE ROOFTOP EVAPORATIVE COOLER
(WINDOW MODEL FEATURED ON BACK SIDE)**

FEATURES:

- 2 models replace all existing Aspen and Single-inlet coolers
- Easily configured for down or side discharge
- Ultra-quiet prop design
- Lifetime warranty on UV-resistant poly housing
- Fits over existing duct openings
- Hi-density rigid media for 85% cooling efficiency
- Aluminum extruded PSC motor for maximum efficiency
- Optional thermostat available

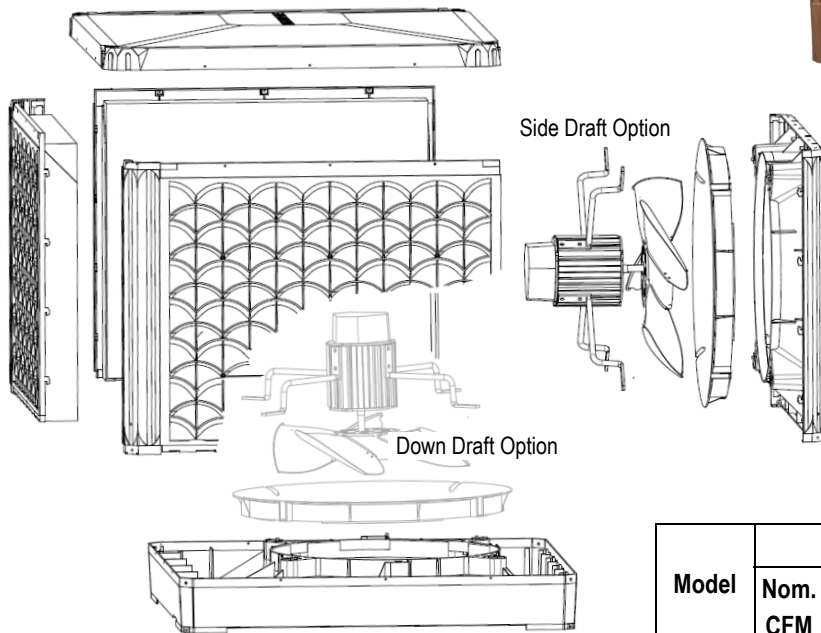

Performance Specifications

Model	Air Delivery VS Static Pressure							HP	Motor Elec.	
	Nom. CFM	Water Inch Column							115V / 60HZ	High / Low
		0	0.1	0.2	0.3	0.4	0.5			
DX4800	4800	3770	3620	3390	3080	2870	2610	1/2	5.2A / 3.3A	
DX6800	6800	5030	4810	4590	4360	4080	3900	3/4	7.0A / 4.8A	

Dimensional Specifications

Model	Air Discharge Type	Drive	Cabinet Dims. (In.)			Duct Location				Drain Location		Pan Dim. (In.)	Weight (lbs)		Media Dims. (In.) 3 pcs per L x W x H ea.
			Height	Width	Depth	Opening		Position		Position			Ship	Operating	
						A	B	E	F	G	J				
DX4800	Down, side	Direct	25 5/8	32	31	16 1/2	16 1/2	7 3/4	5 7/8	16	4 1/8	4	67	135	19 x 25 x 3
DX6800	Down, side	Direct	32	36	35	20	20	8	7 1/2	18	4 3/4	4 7/8	84	170	24 x 28 1/2 x 3

Discharge View

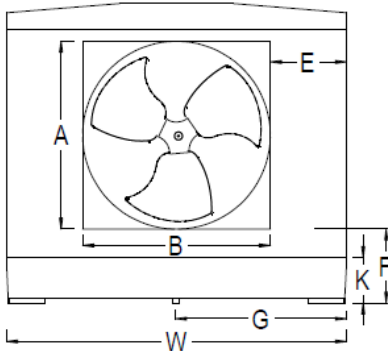

Media Side View

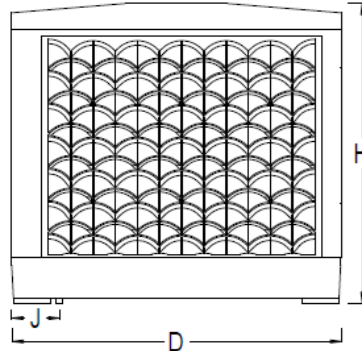

Bottom View

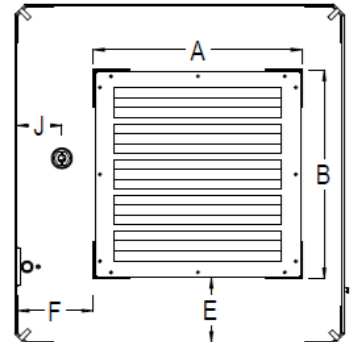

**DIRECT DRIVE WINDOW EVAPORATIVE COOLER
(ROOFTOP MODELS FEATURED ON BACK SIDE)**

FEATURES:

- Easily installs through existing window openings
- Save up to 75% over refrigerated air systems
- Ultra-quiet prop design
- Delivers cool, fresh air
- Filters as it cools
- Durable, lightweight, impact resistant polypropylene housing
- Easy to operate



Performance Specifications

Model	Nom. CFMs	Motor Electrical				
		Speeds	Volts	Amps High / Low	Phase	Hz
DX6100	6100	2	115	3.6 / 2.9	1	60

Dimensional Specifications

Model	Air Discharge Type	Drive	Cabinet Dims. (In.)			Duct Location (In.)					Pan Dim. (In.)	Weight (lbs)		Media Dims. (In.) 4 pcs per L x W x H ea.
			Height	Width	Depth	Opening			Position			Ship	Operating	
			H	W	D	A	B	C	E	F	K			
DX6100	Window	Direct	35 1/2	29 1/4	26 3/4	21 5/8	21 5/8	10	10	3 3/4	3 5/8	62	120	29 x 10 1/2 x 2 3/4

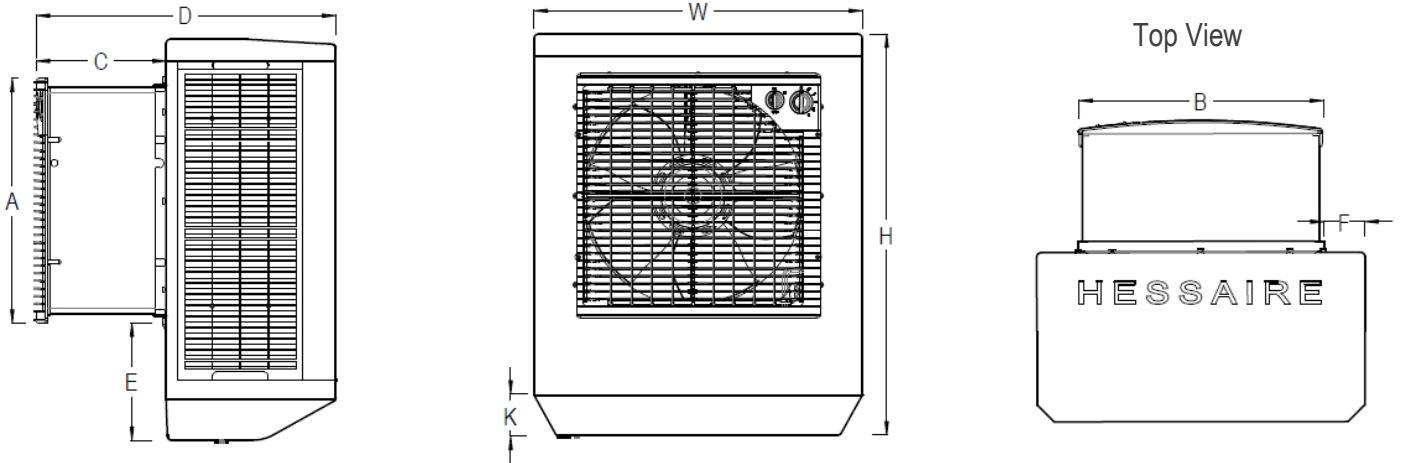

Component View

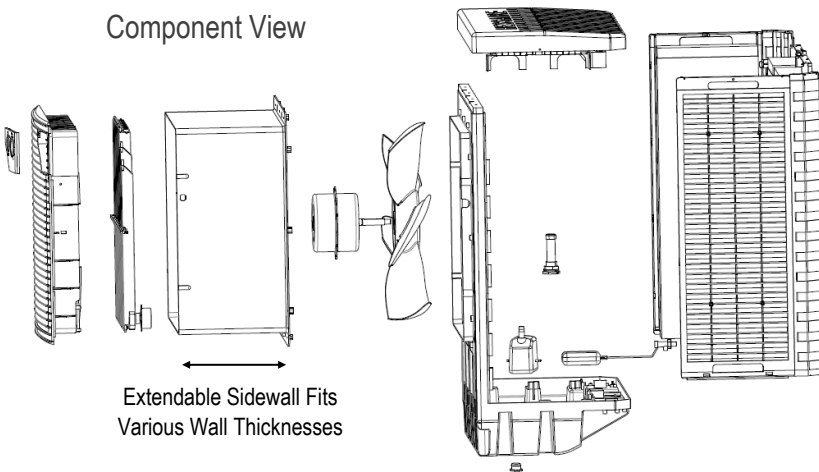

Installed

