

This Owner's Manual is provided and hosted by [Appliance Factory Parts](#).



Broil King 8762-47 Owner's Manual

[Shop genuine replacement parts for Broil King 8762-47](#)

Broil King®

[Find Your Broil King Grill Parts - Select From 1350 Models](#)

----- Manual continues below part list -----

Available Replacement Parts for Broil King 8762-47

10693-113	ORIFICE SPUD 1.13MM 5/16 32
10114-16	HOSE & REG ASSY 17 INCH LP +

Broil King®

ASSEMBLY MANUAL & PARTS LIST - MANUEL DE MONTAGE & LISTE DE PIÈCES - MANUAL DE ARMADO Y LISTA DE PARTES



Broil King
BARON 520 PRO
8762-14
8762-17
BARON 520
8762-54
8762-57



Broil King
BARON S520 PRO
8763-14
8763-17

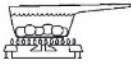

Broil King
BARON 540 PRO
8762-24
8762-27

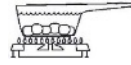

Broil King
BARON S540 PRO
8763-24
8763-27

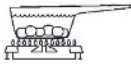

Broil King
BARON 590 PRO
8762-44
8762-47
BARON 590
8762-84
8762-87

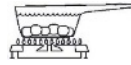
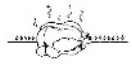

Broil King
BARON S590 PRO
8763-44
8763-47

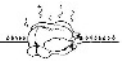



RETAIN FOR FUTURE REFERENCE - VEUILLEZ CONSERVER POUR REFERENCE ULTERIEURE - CONSERVAR PARA FUTURAS CONSULTAS

Onward
MANUFACTURING COMPANY
SINCE 1906
585 KUMPF DRIVE LIMITED
WATERLOO, ONTARIO, CANADA
N2V 1K3

info@omcbbq.com
1-800-265-2150

50084-E80 REV A 08/20

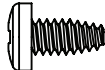
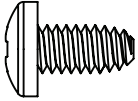
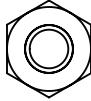
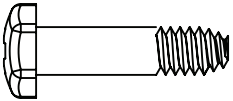
HARDWARE INCLUDED / MATERIAL INCLUS

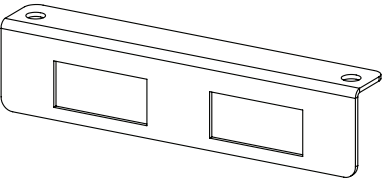
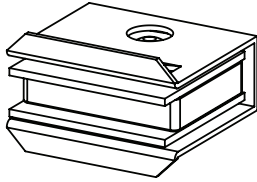
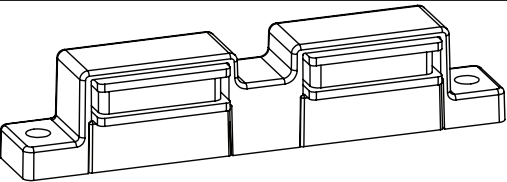
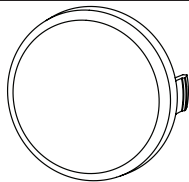
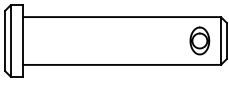
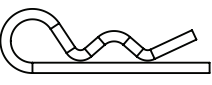
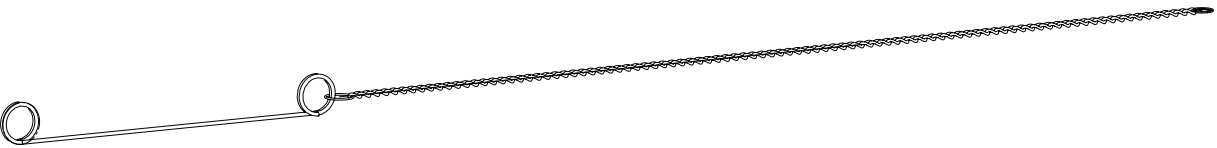
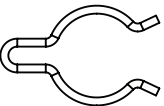
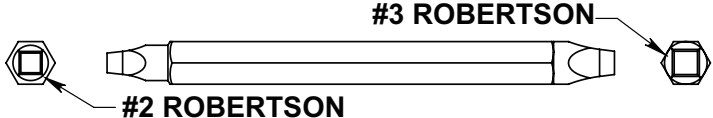
S21124		(8)	Y-29304		(2)
Y-12865		(22)	Y-11793		(2)
Y-11551		(2)	Y-12124		(2)
56039-211		(1)	Y-12223		(2)
Y-12229		(1)	32001-151		(4)
S21235		(2)	S21233		(2)
20005-000					(1)
Y-11230		(1)	 <p>#3 ROBERTSON</p> <p>#2 ROBERTSON</p>		

TOOLS REQUIRED / OUTILS NECESSAIRES

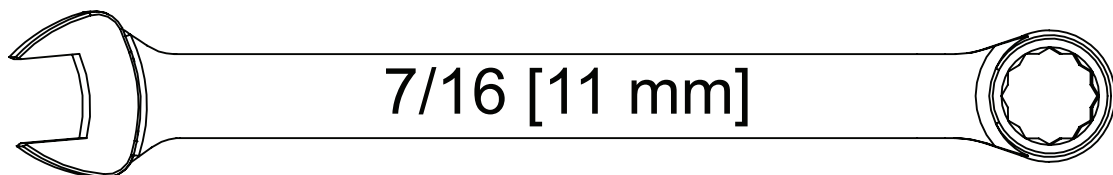

1

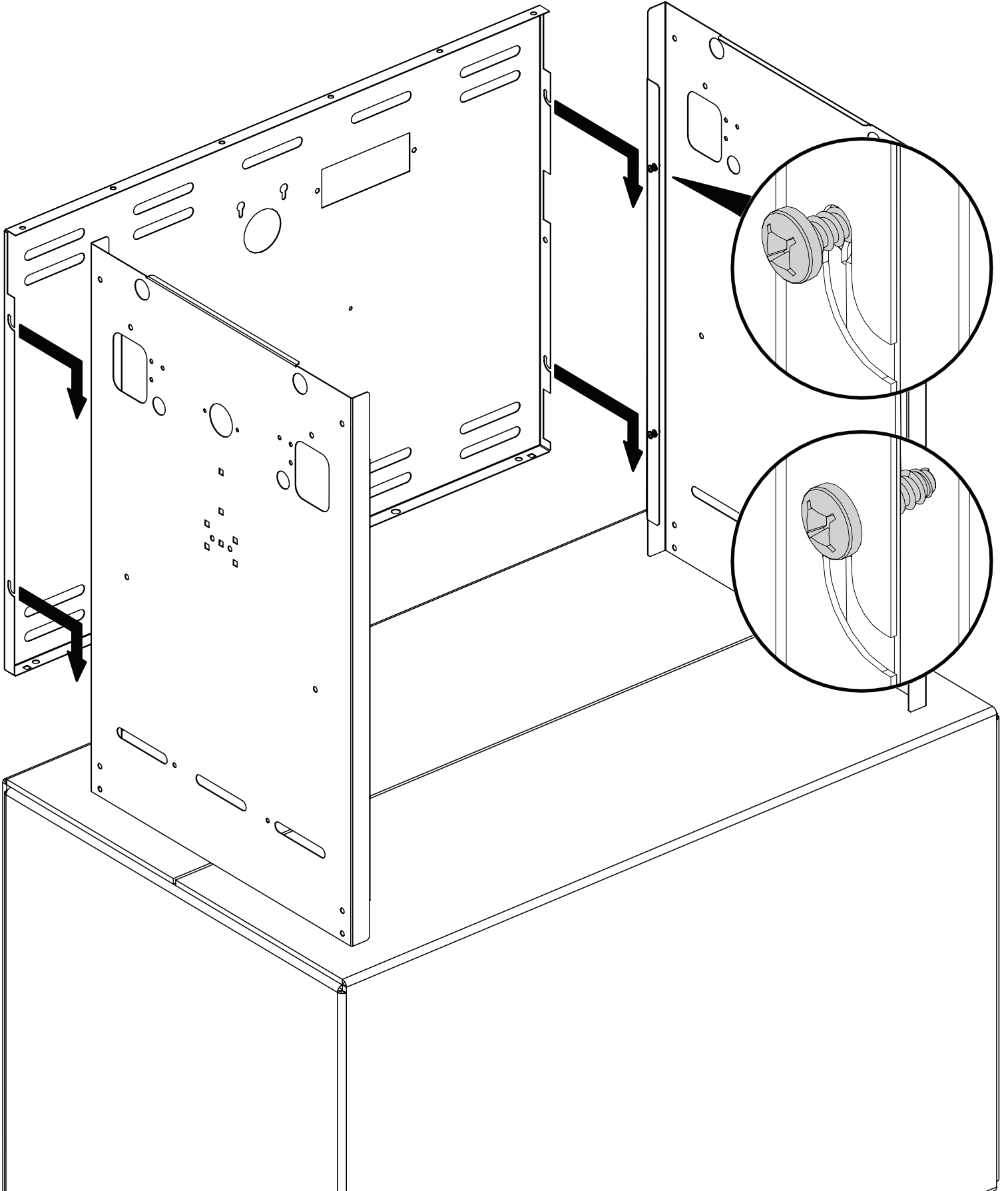

2

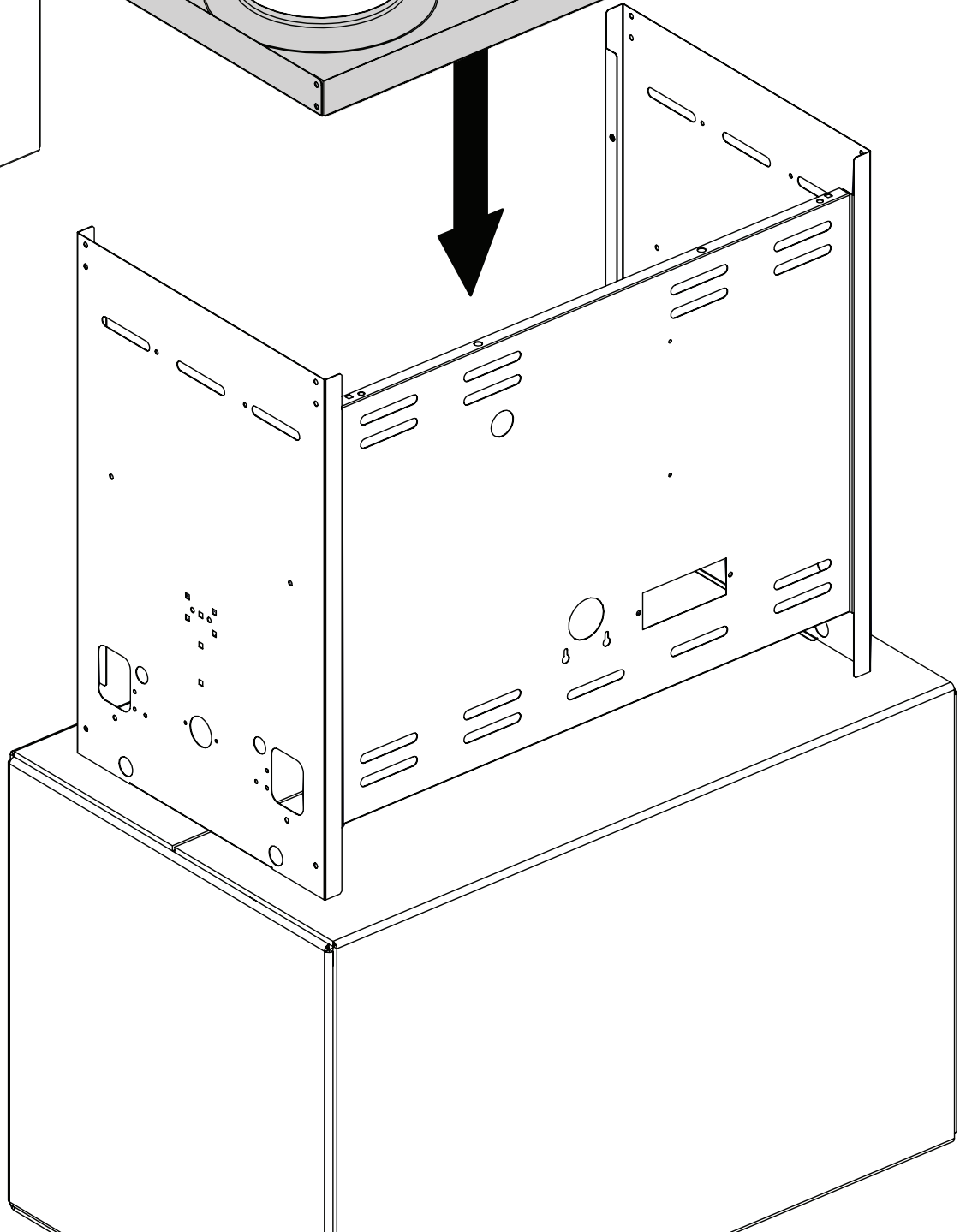
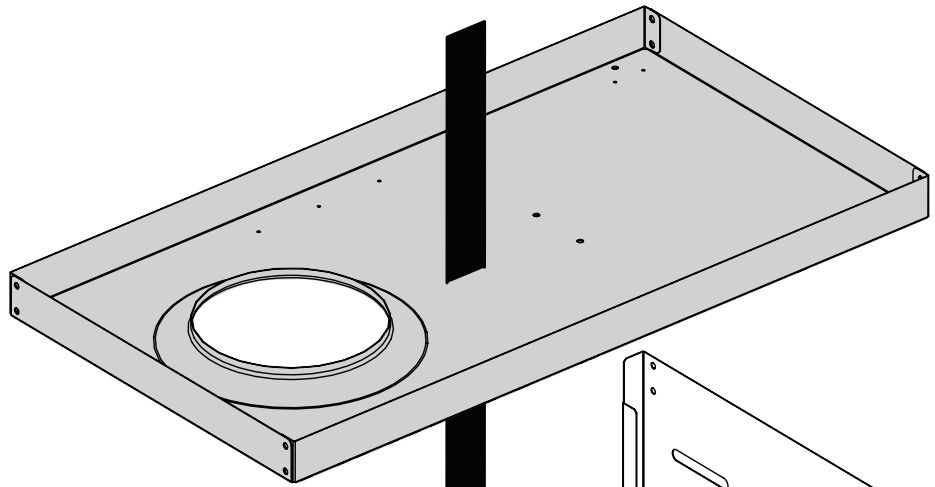
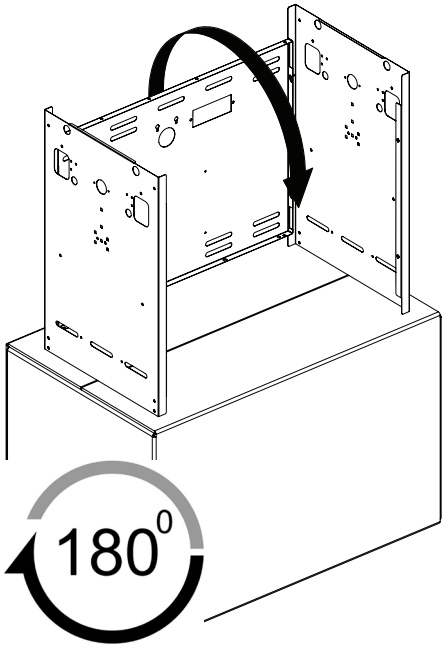

3

(2) 

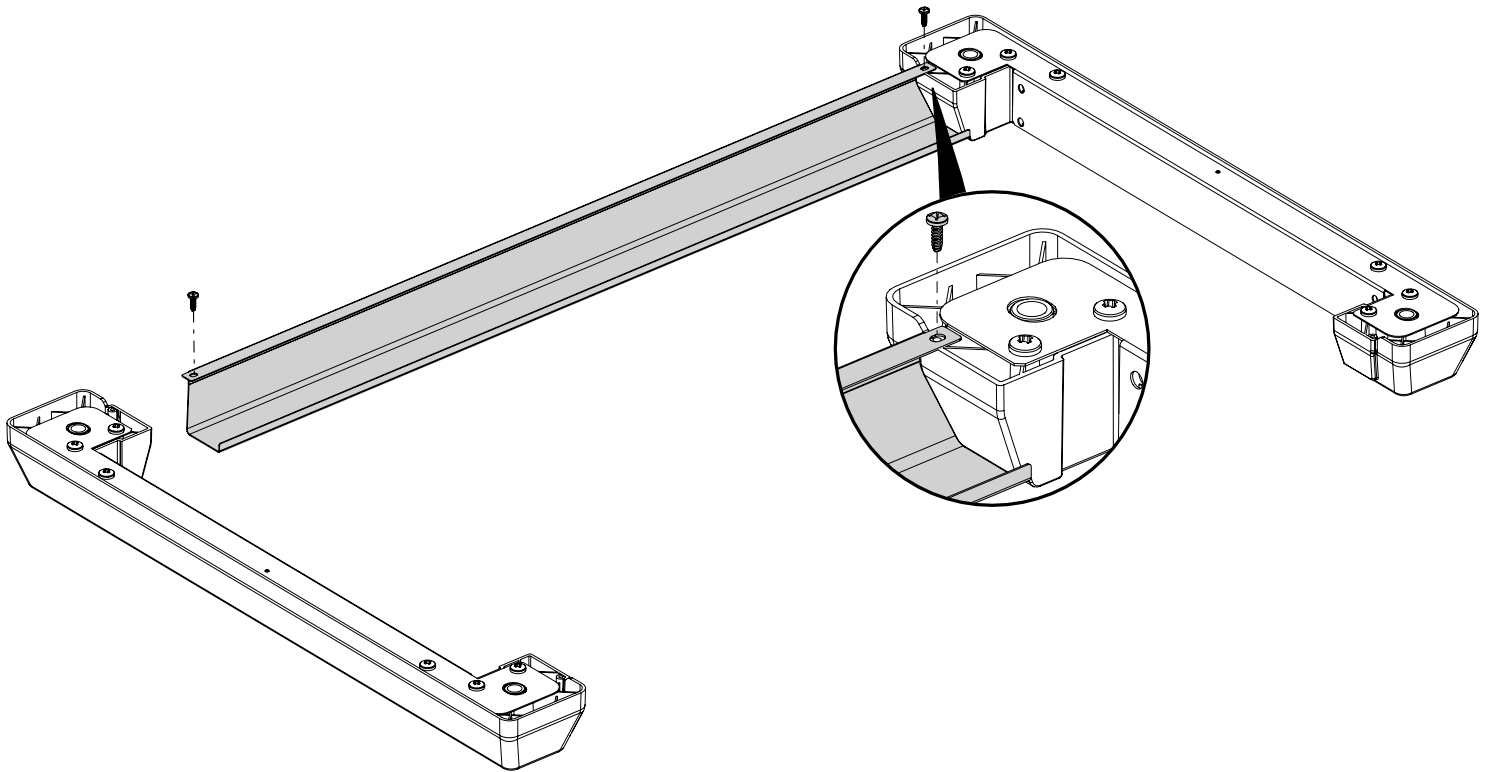

4

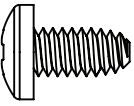
(8) 

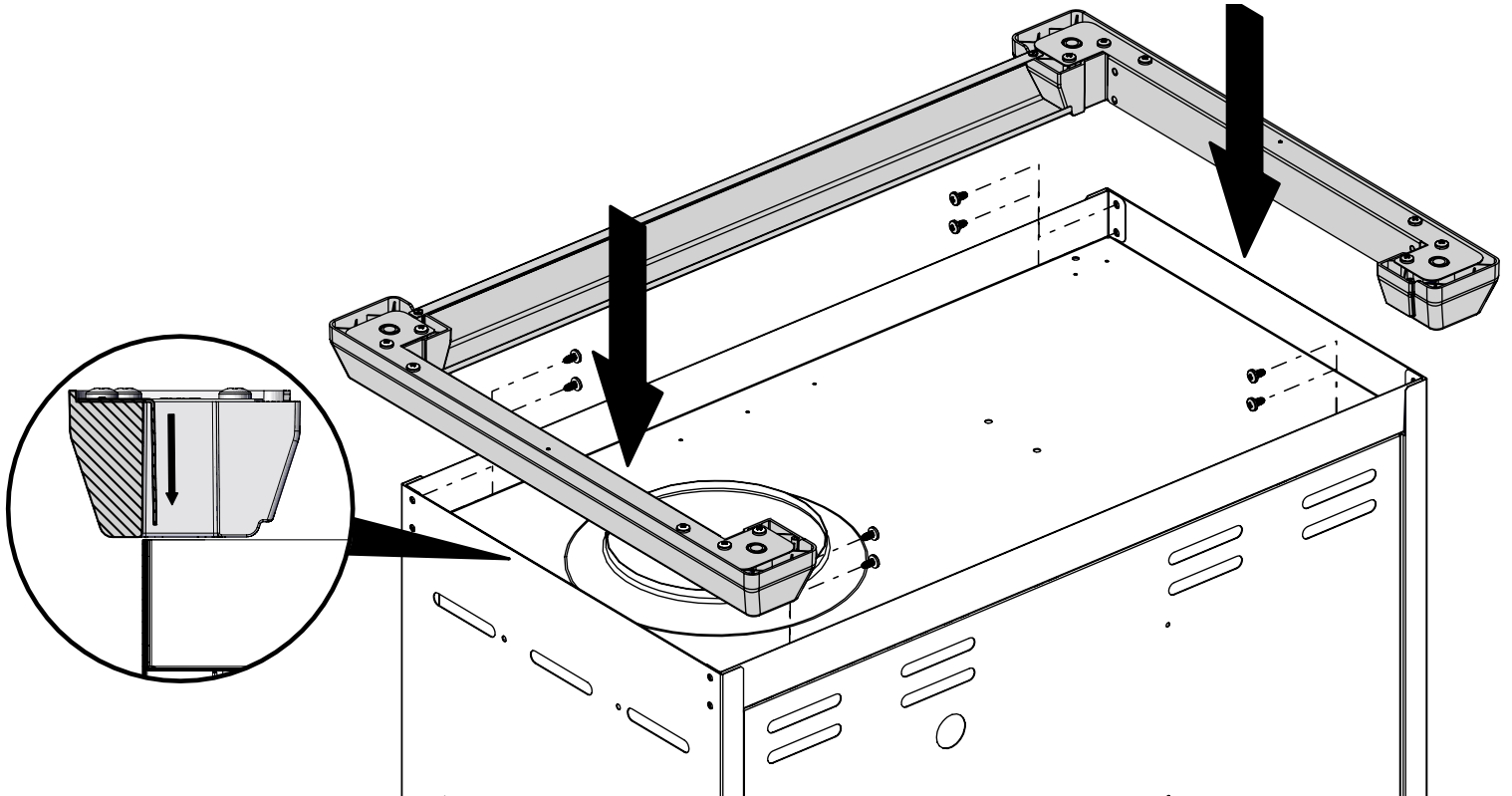

5

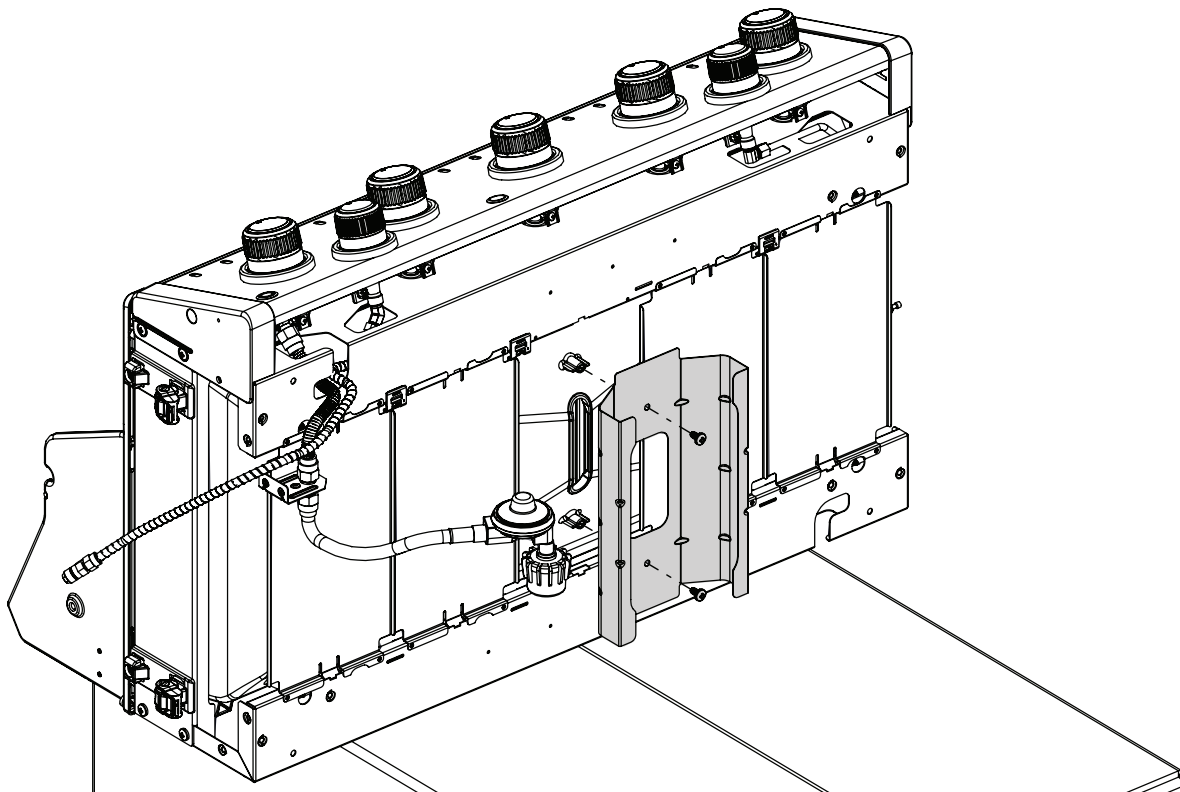
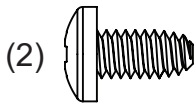

6

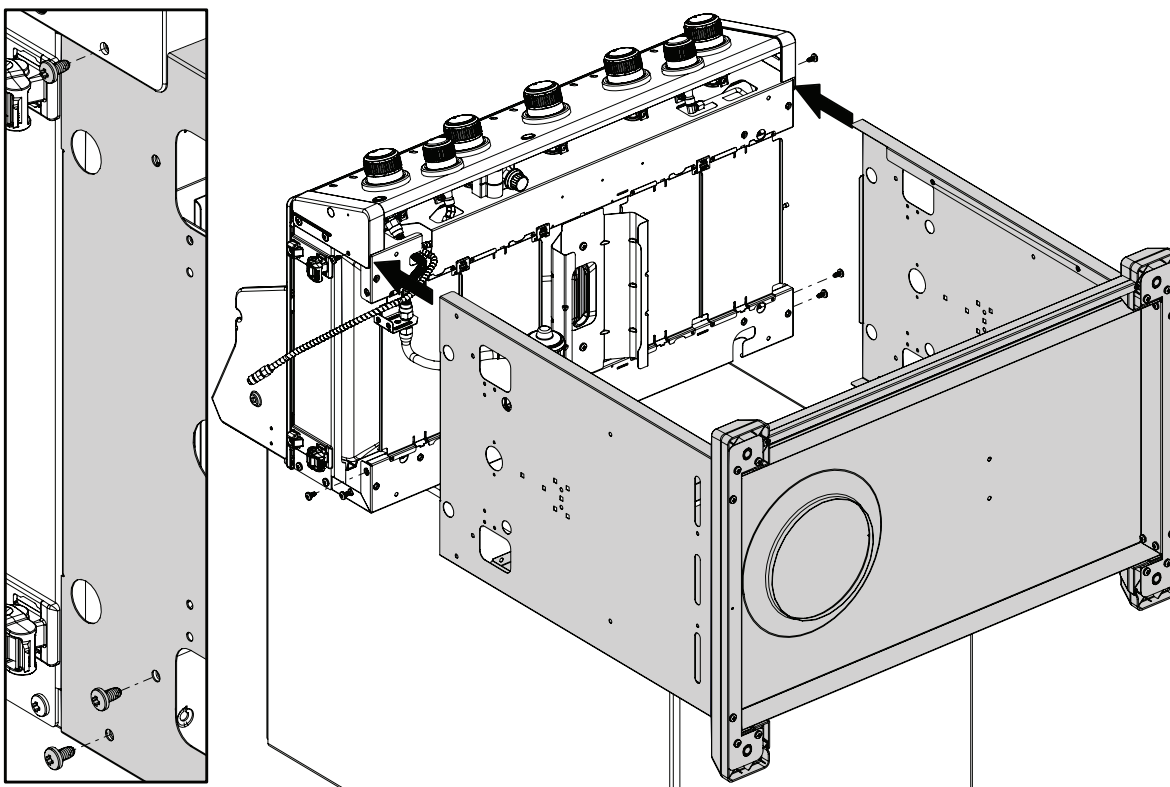
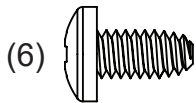

7

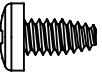
(2) 

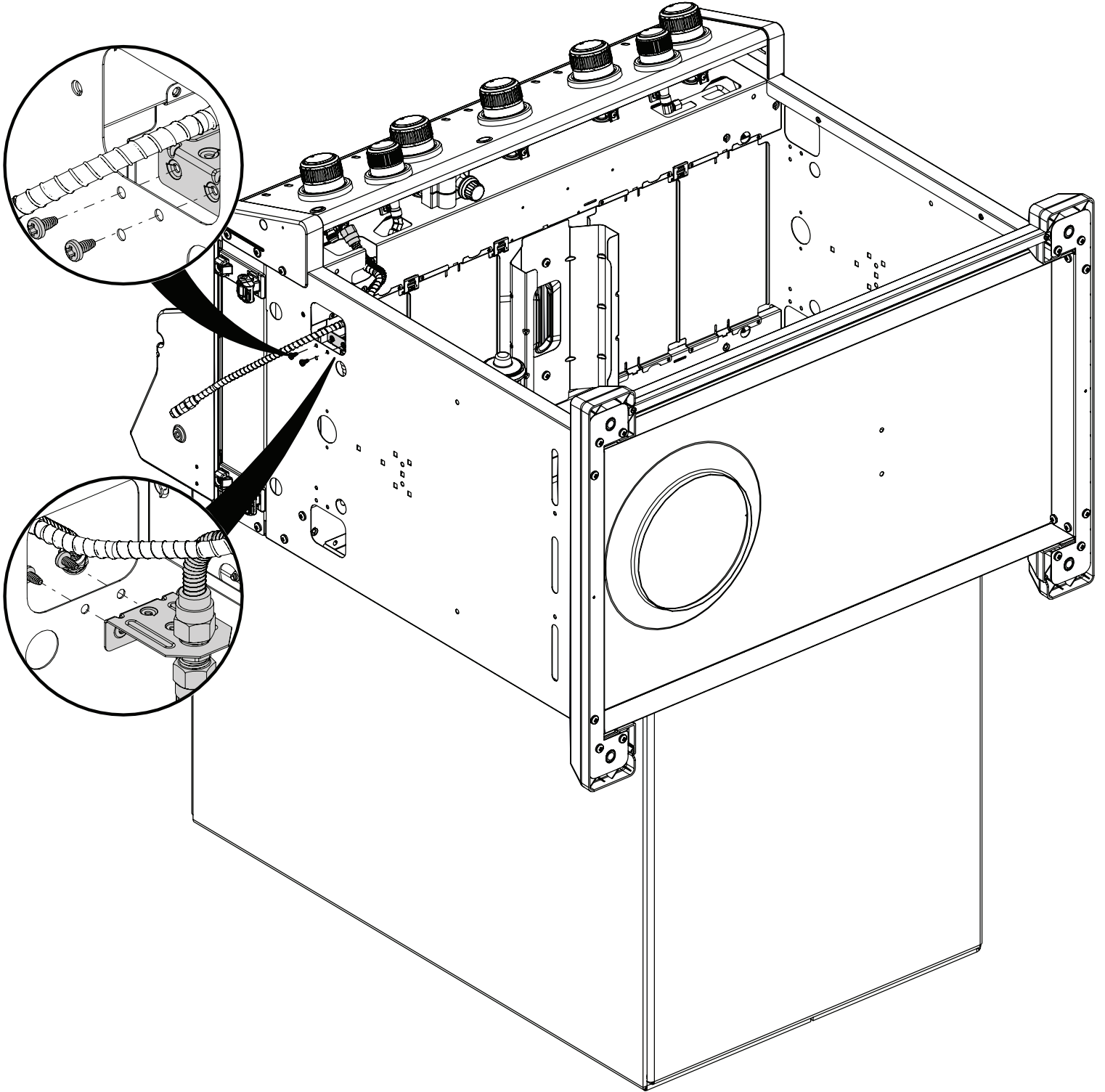

8

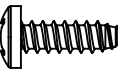
(2) 

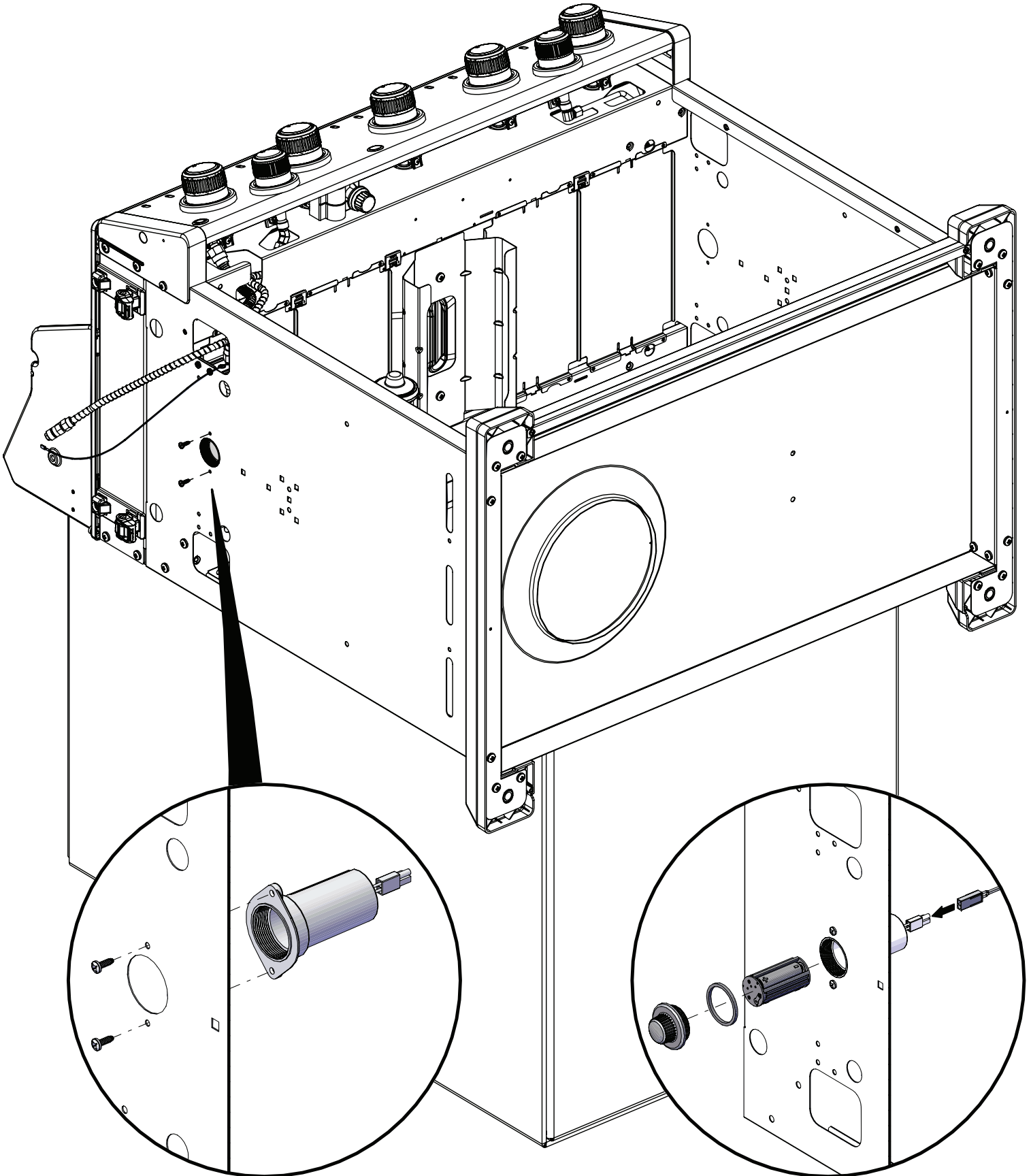

9

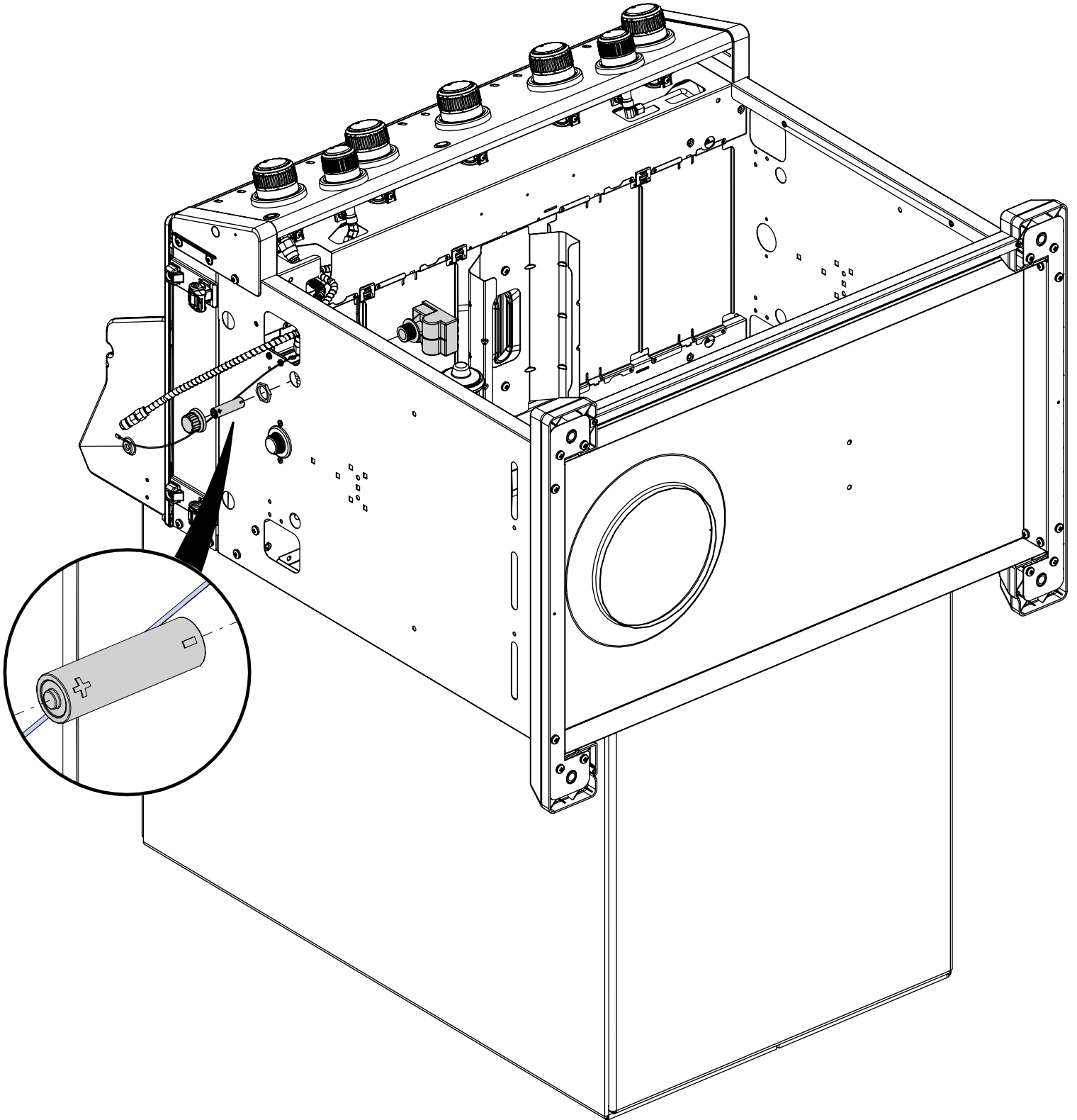

10

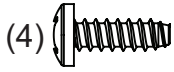

(1)

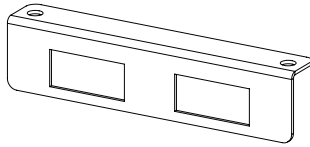

(2)

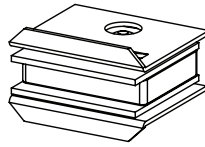

(1)

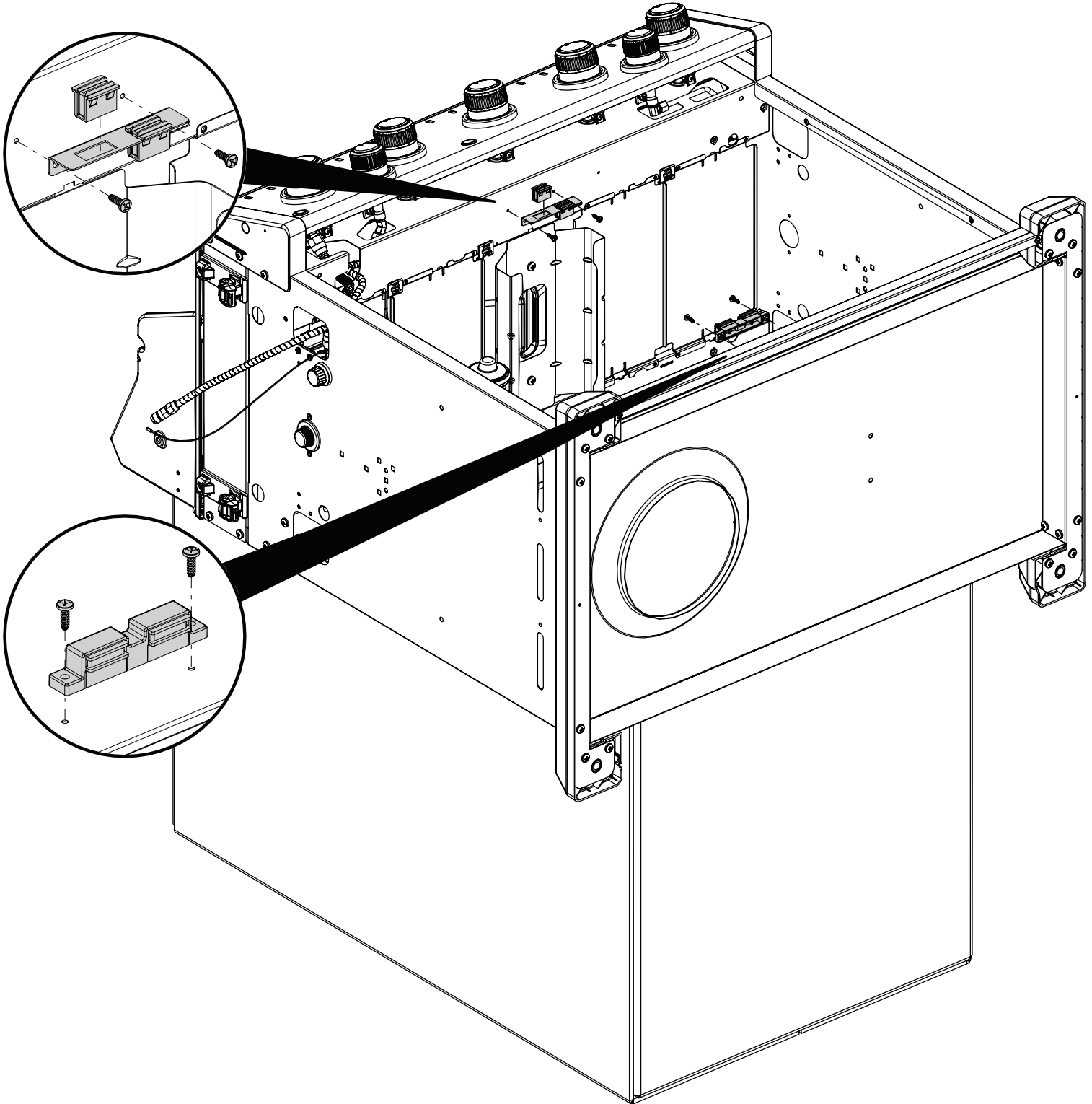
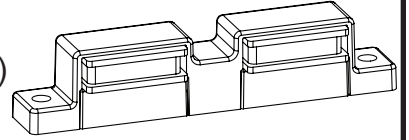

11

(4)

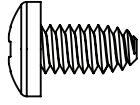

(2)

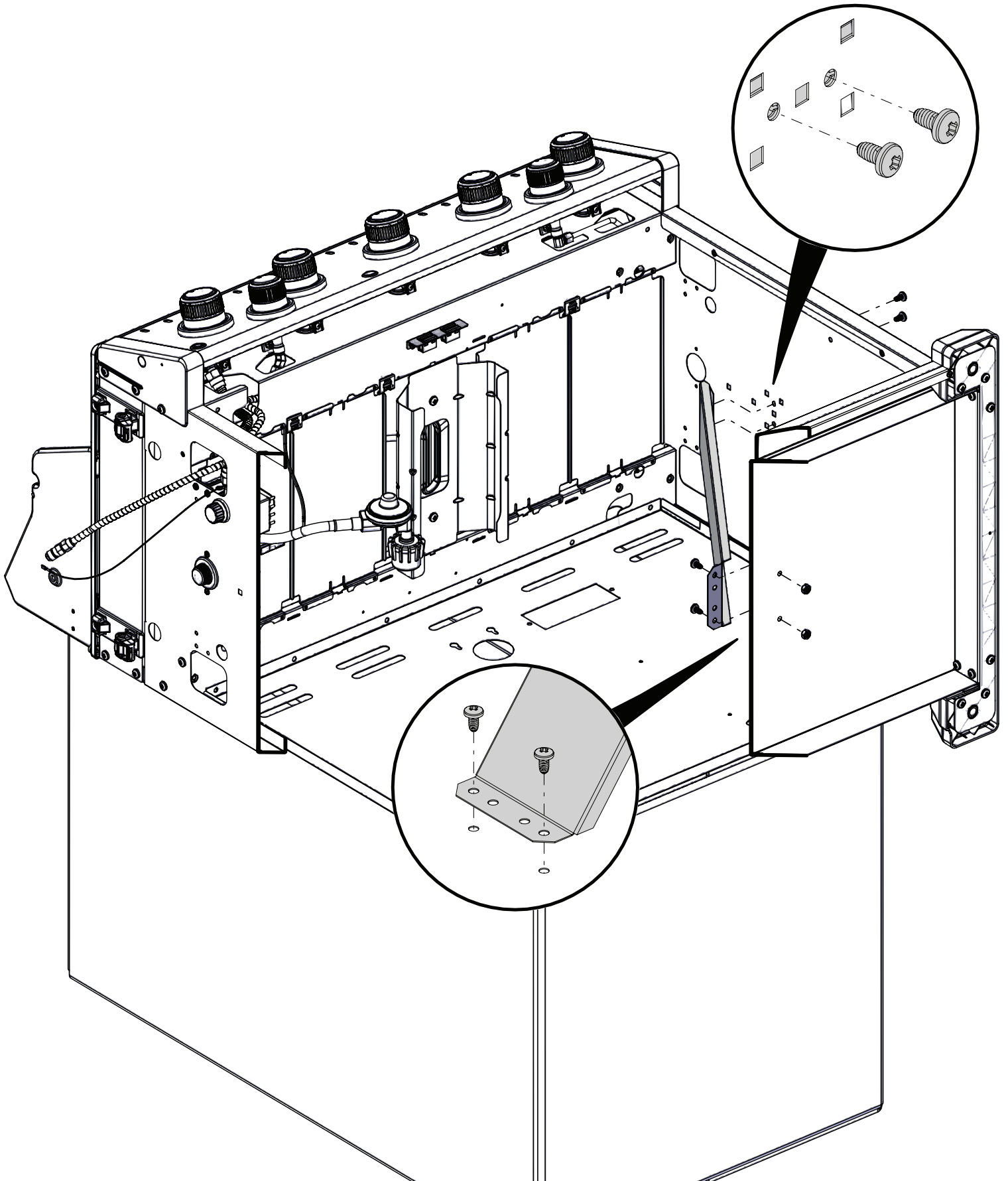
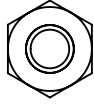

12

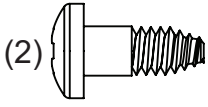
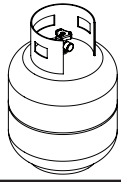

(2)

(2)

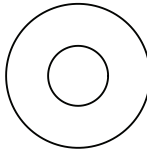

(2)

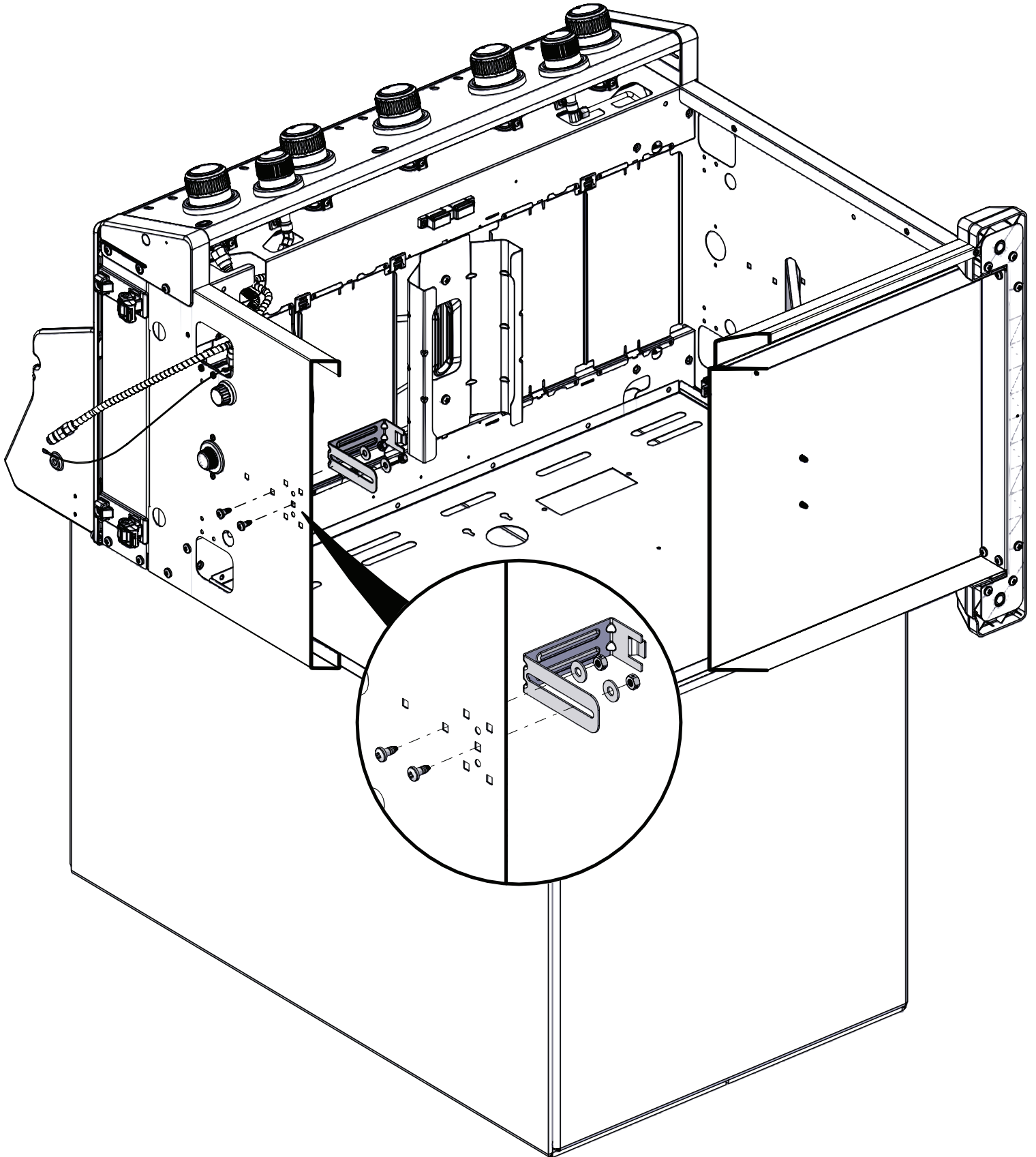
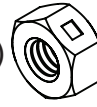

13

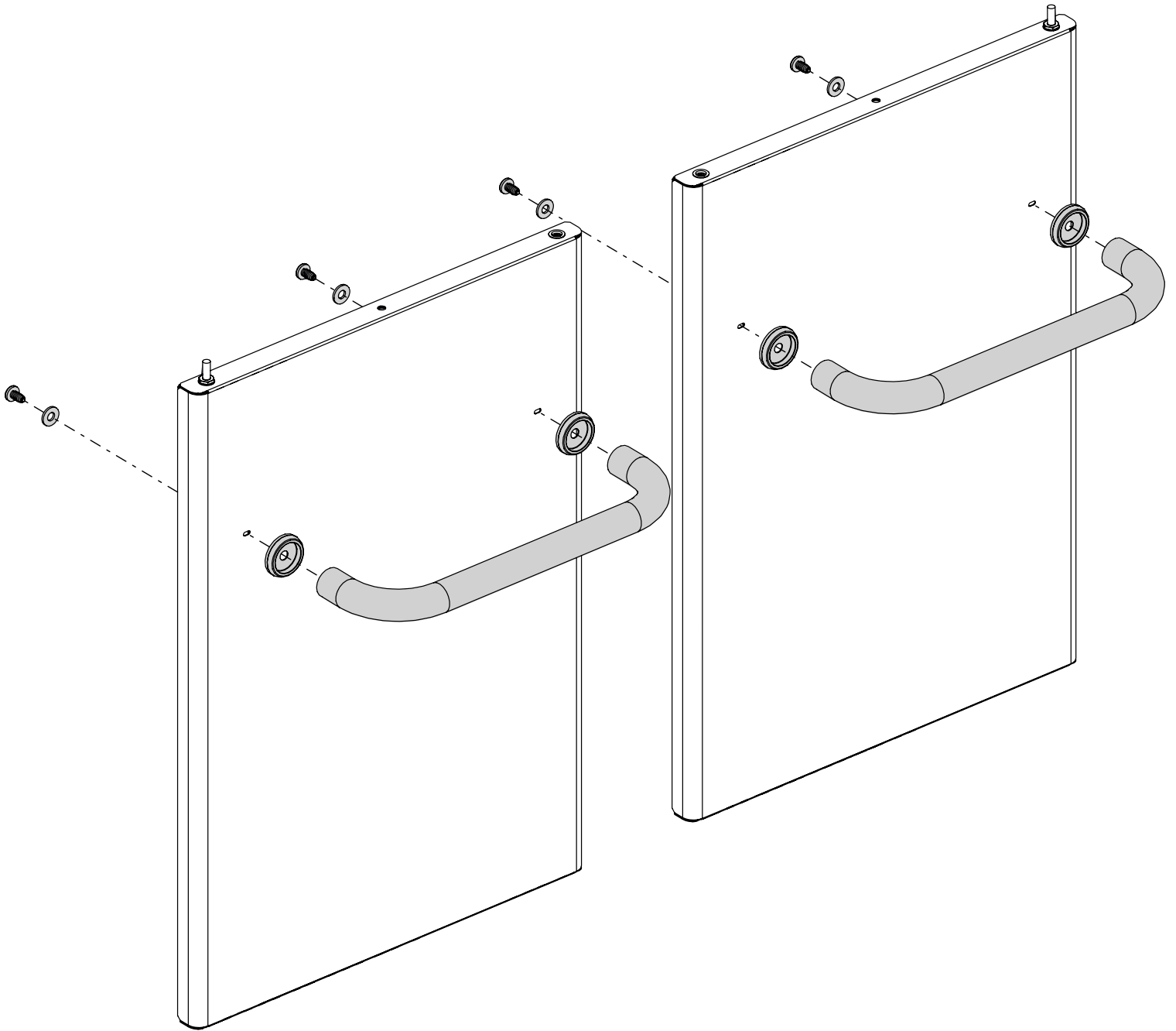
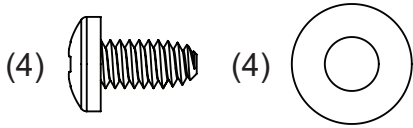

14

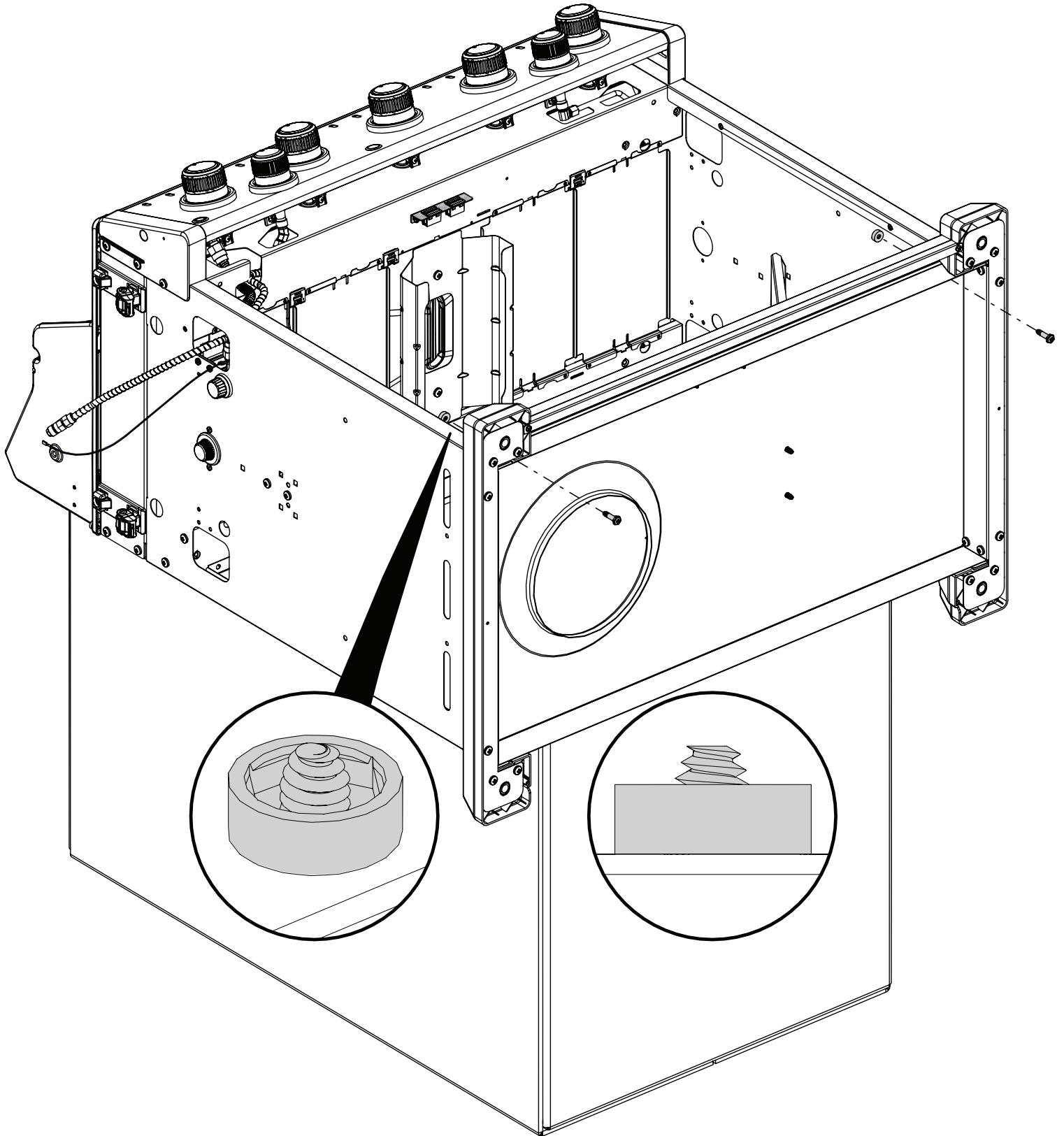
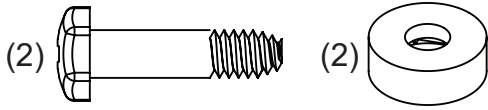

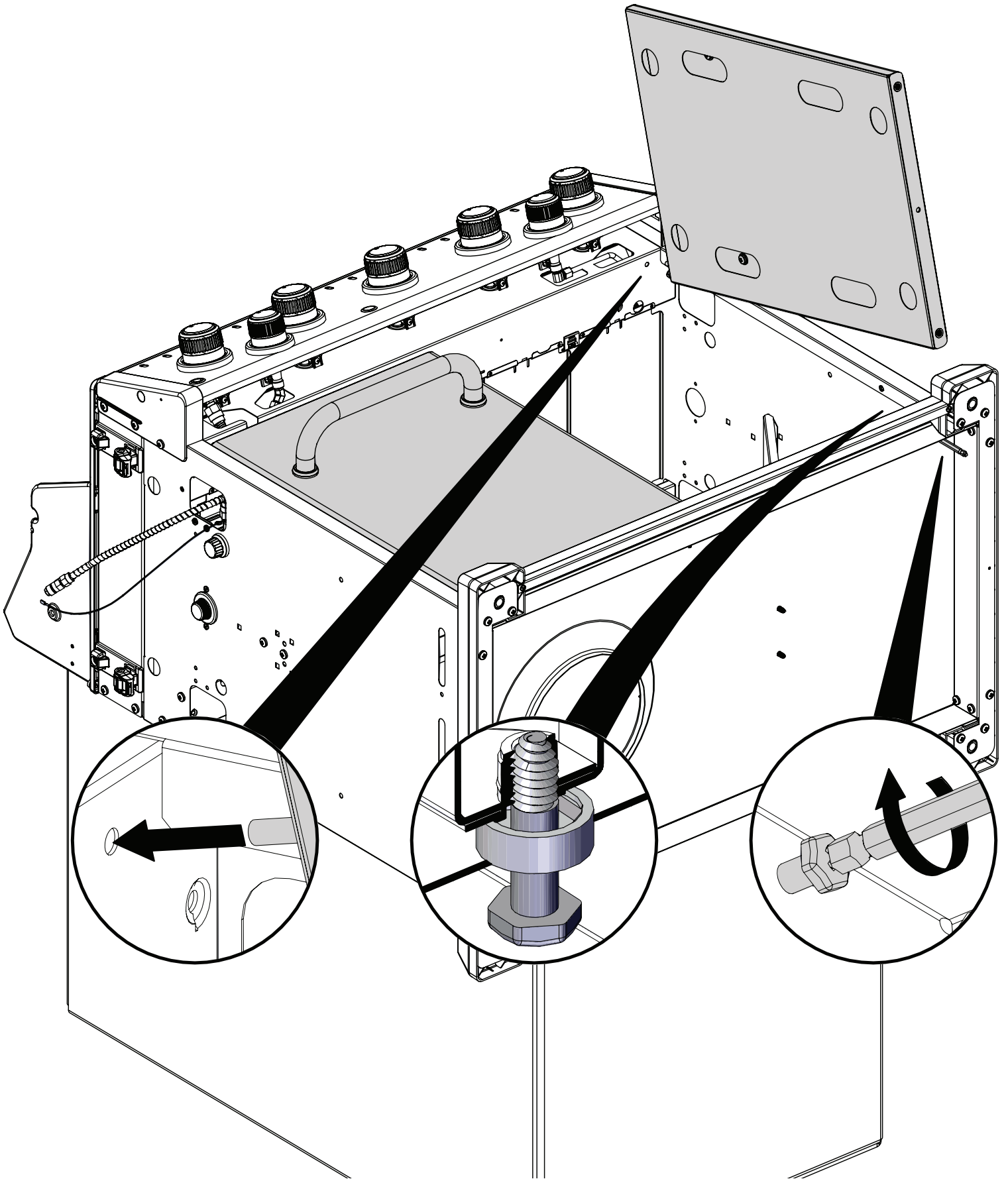

16

(4)

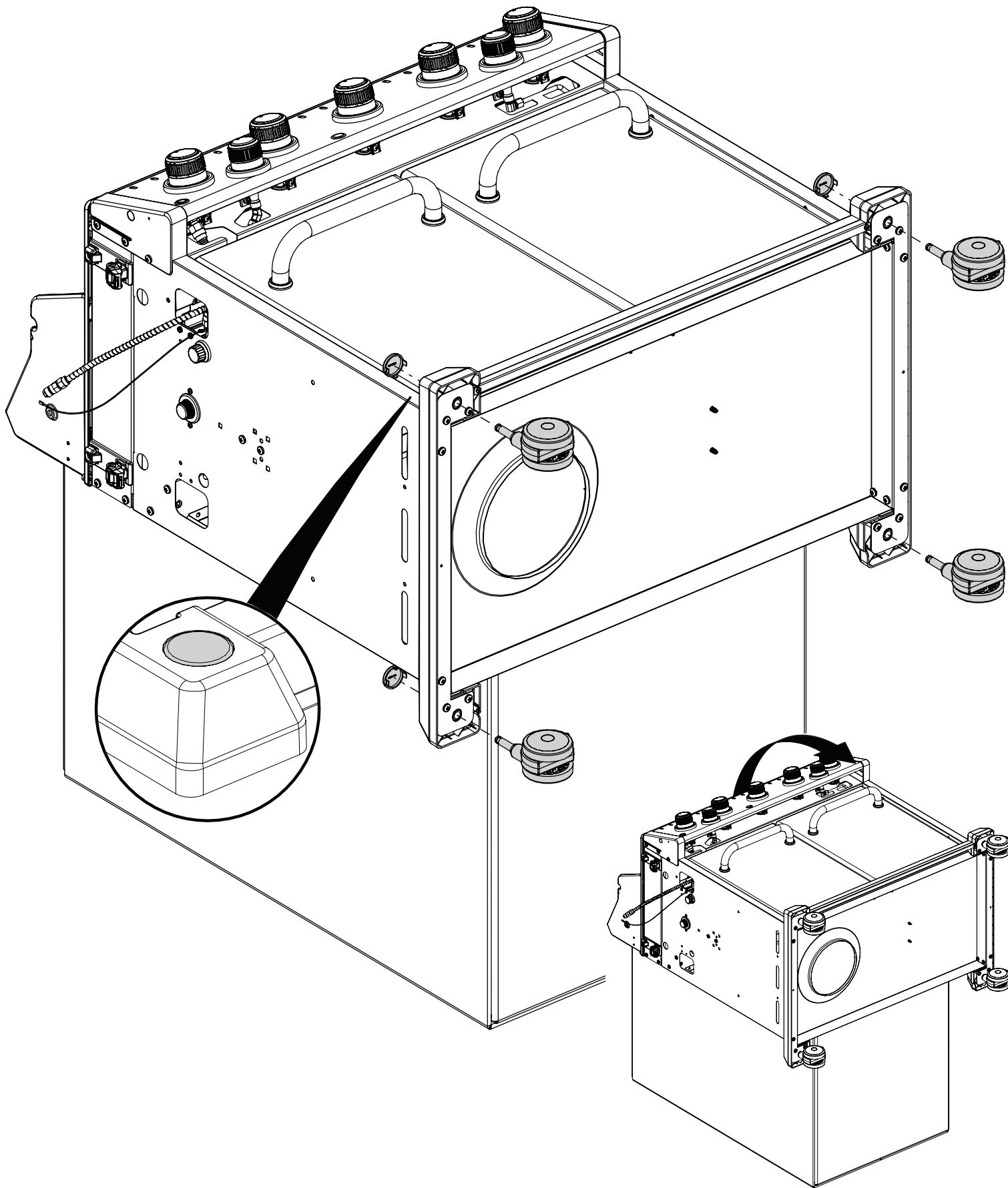
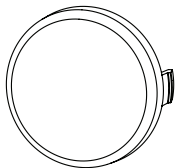

17

(2)

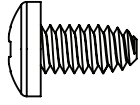

(1)

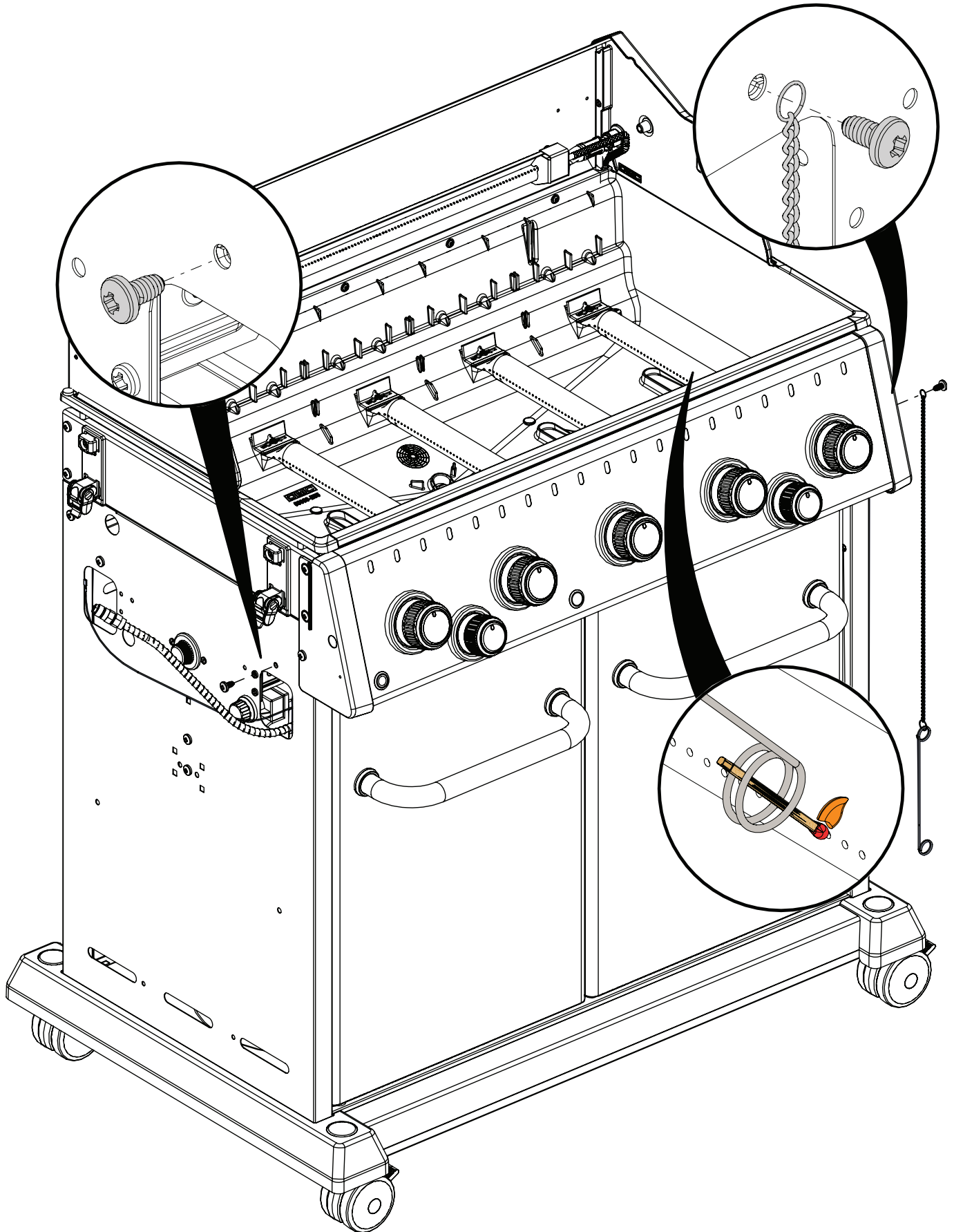

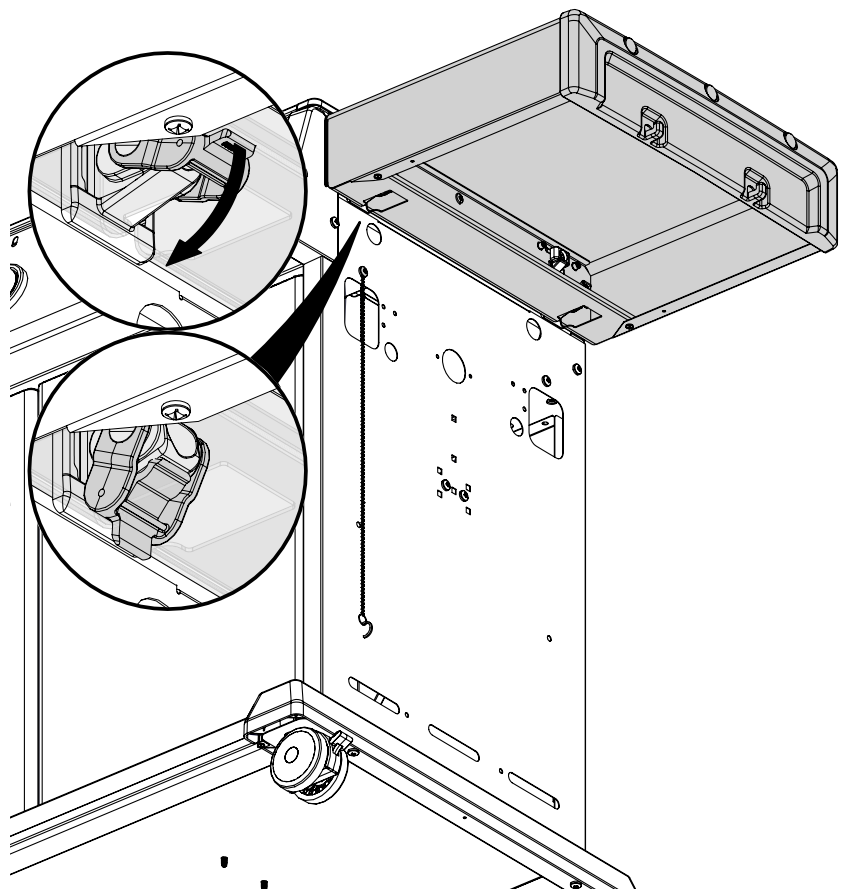
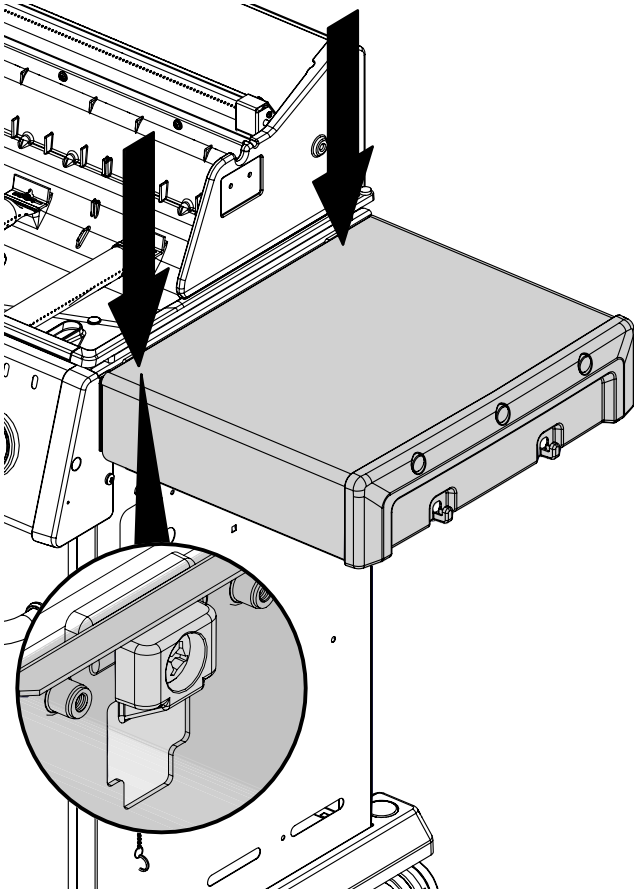
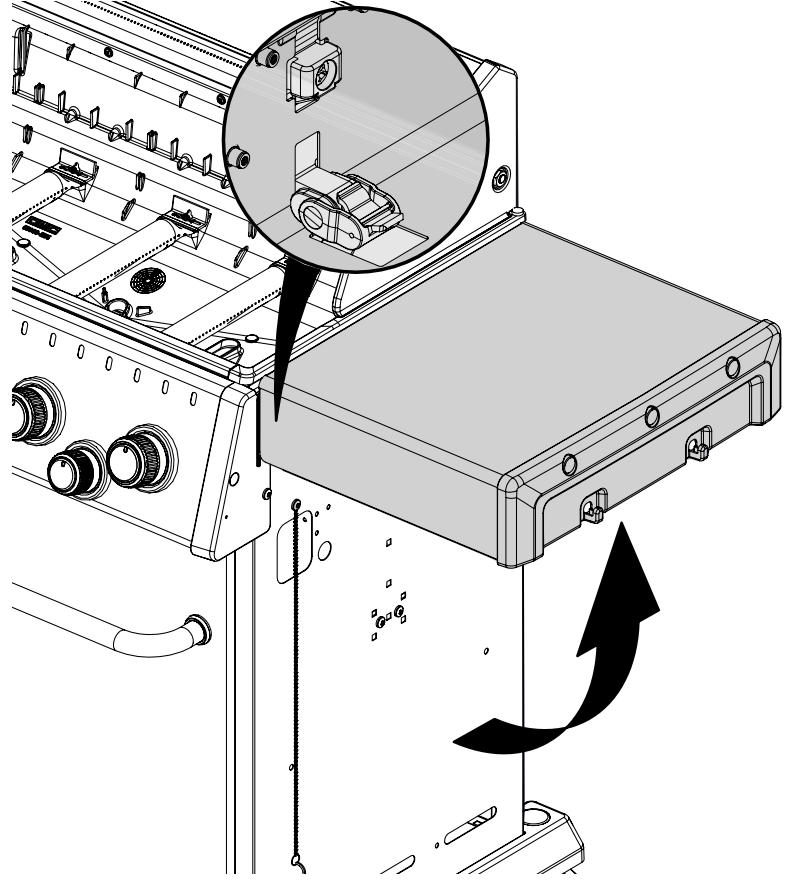
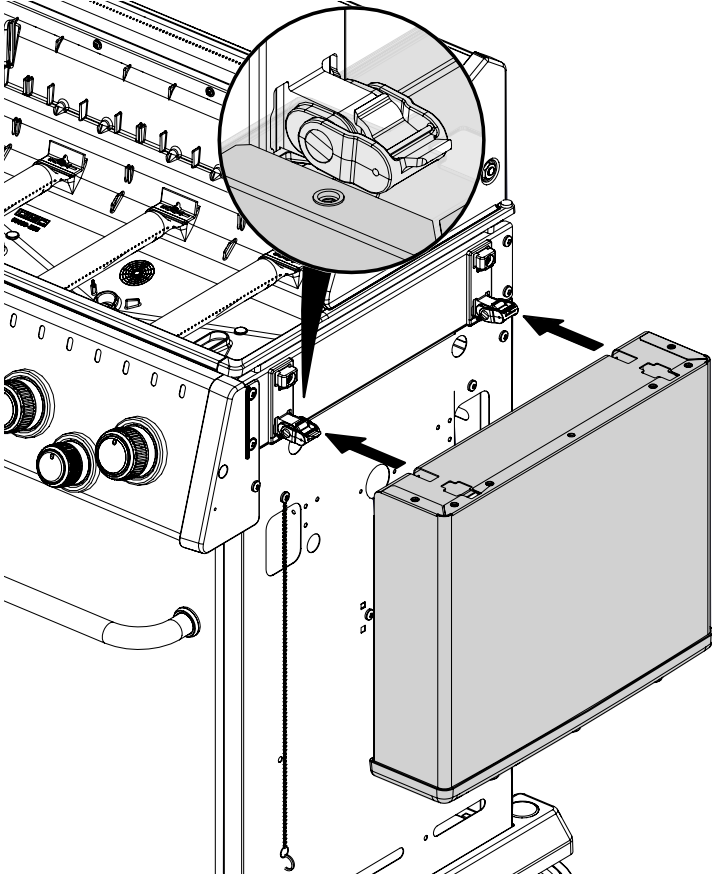

19

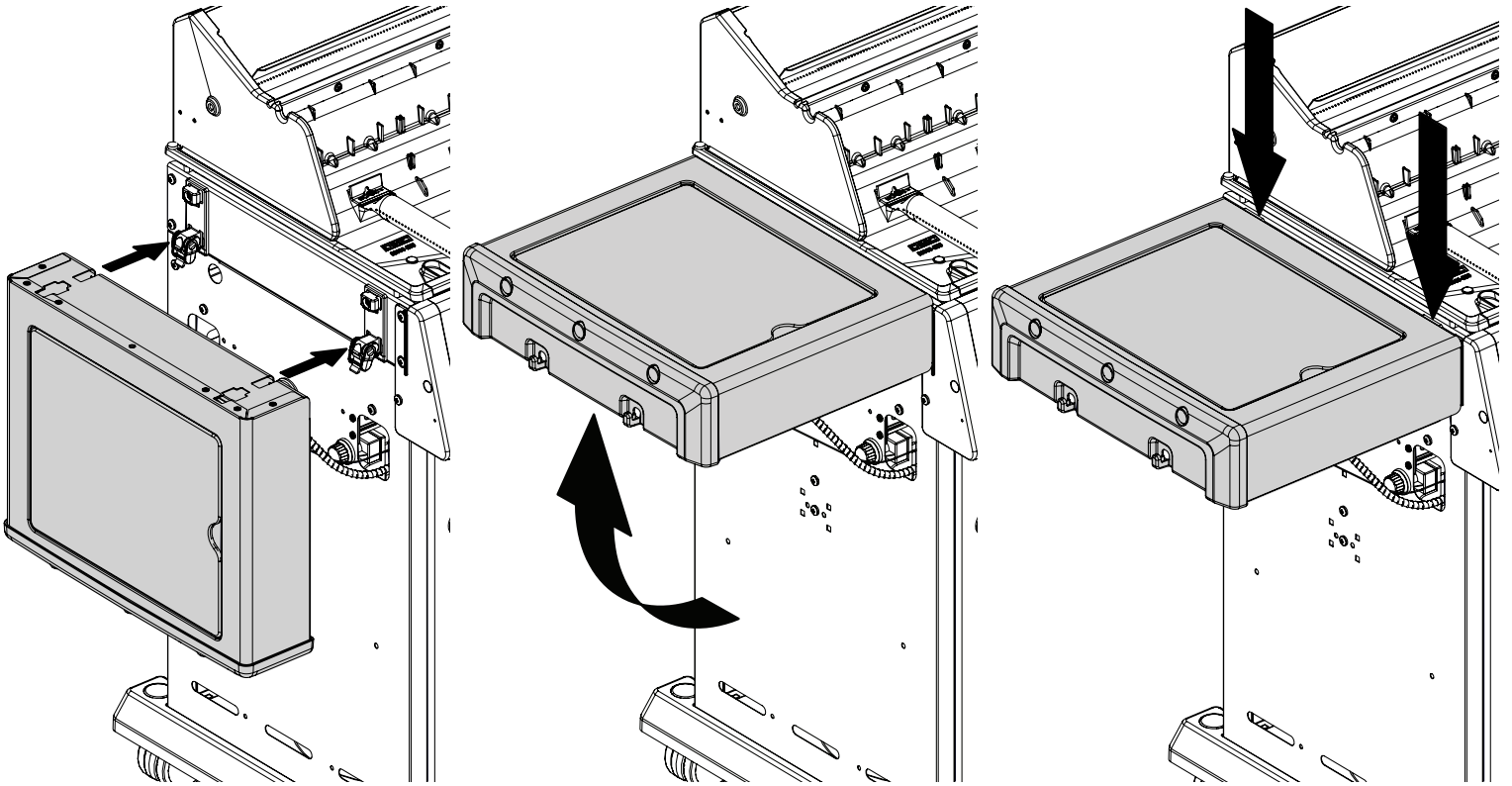

20

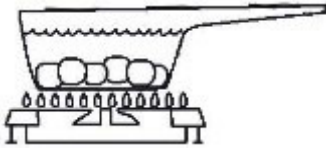

(1)

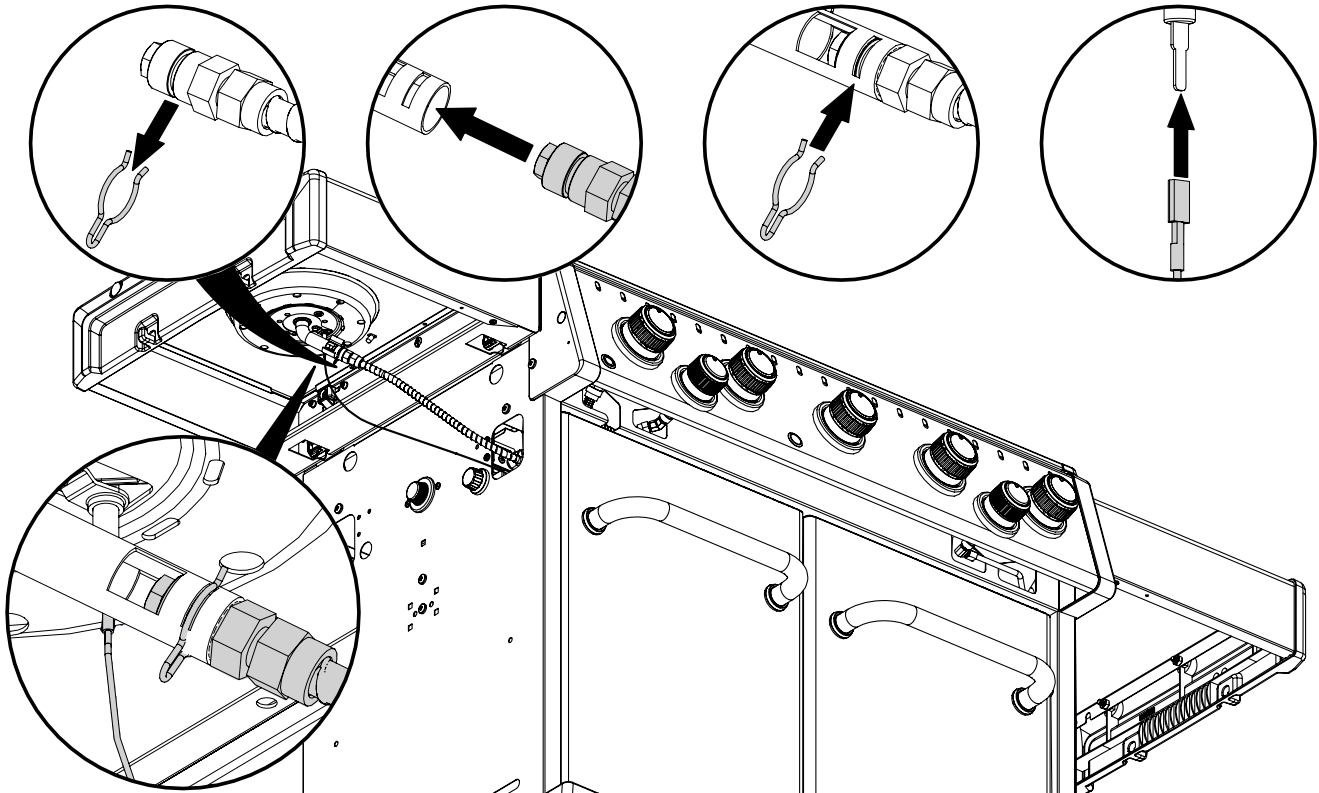
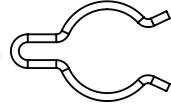

21

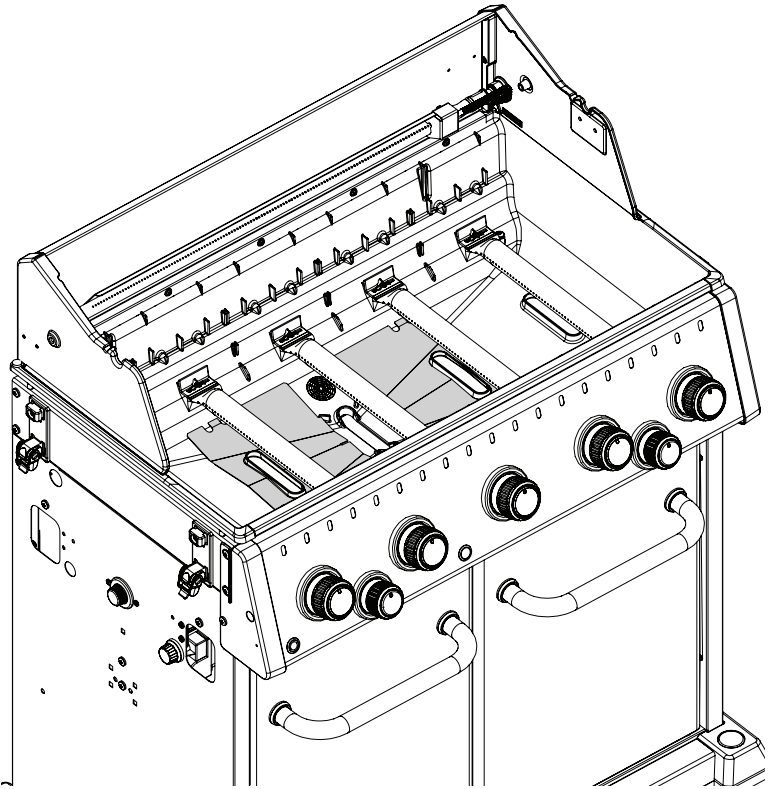
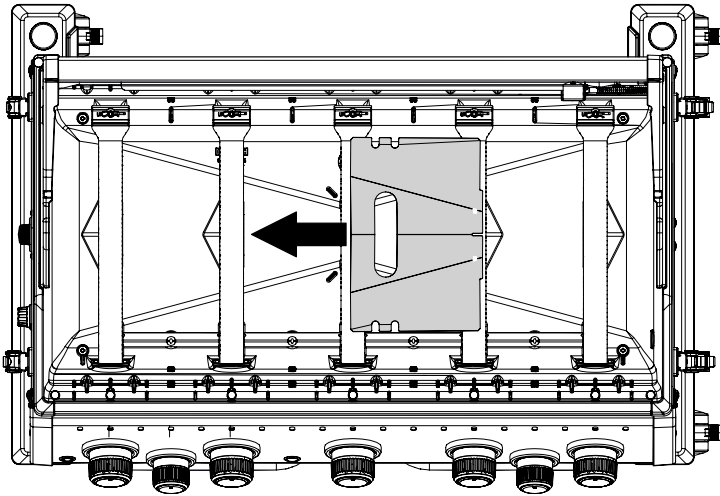

22

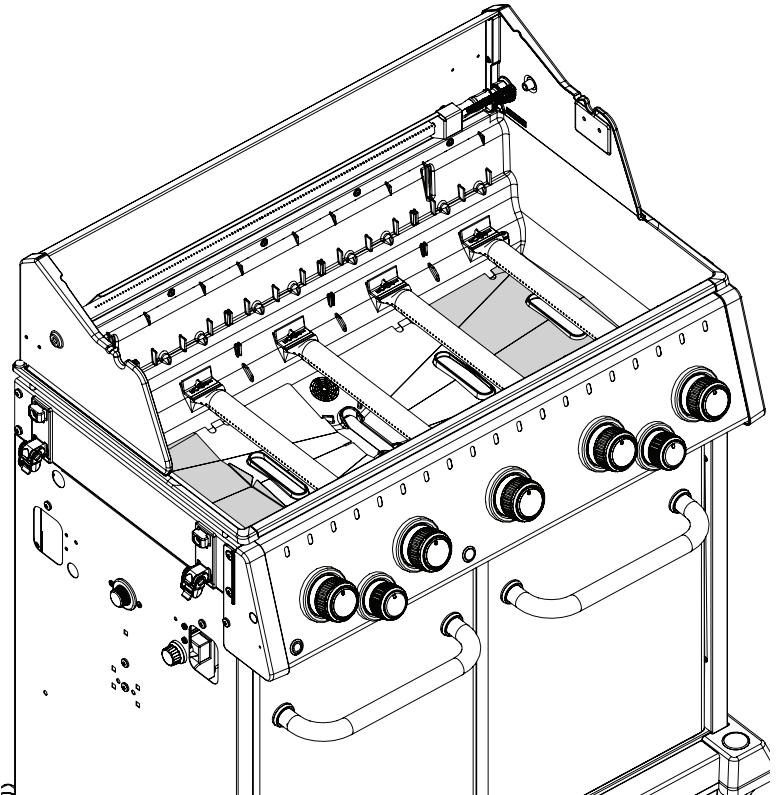
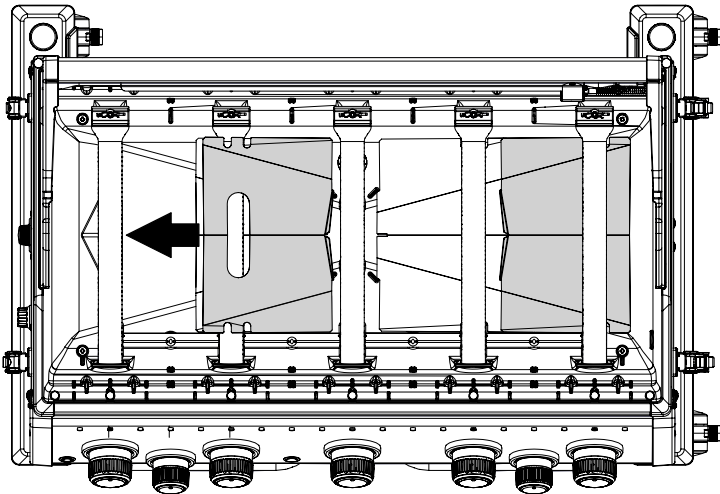

23

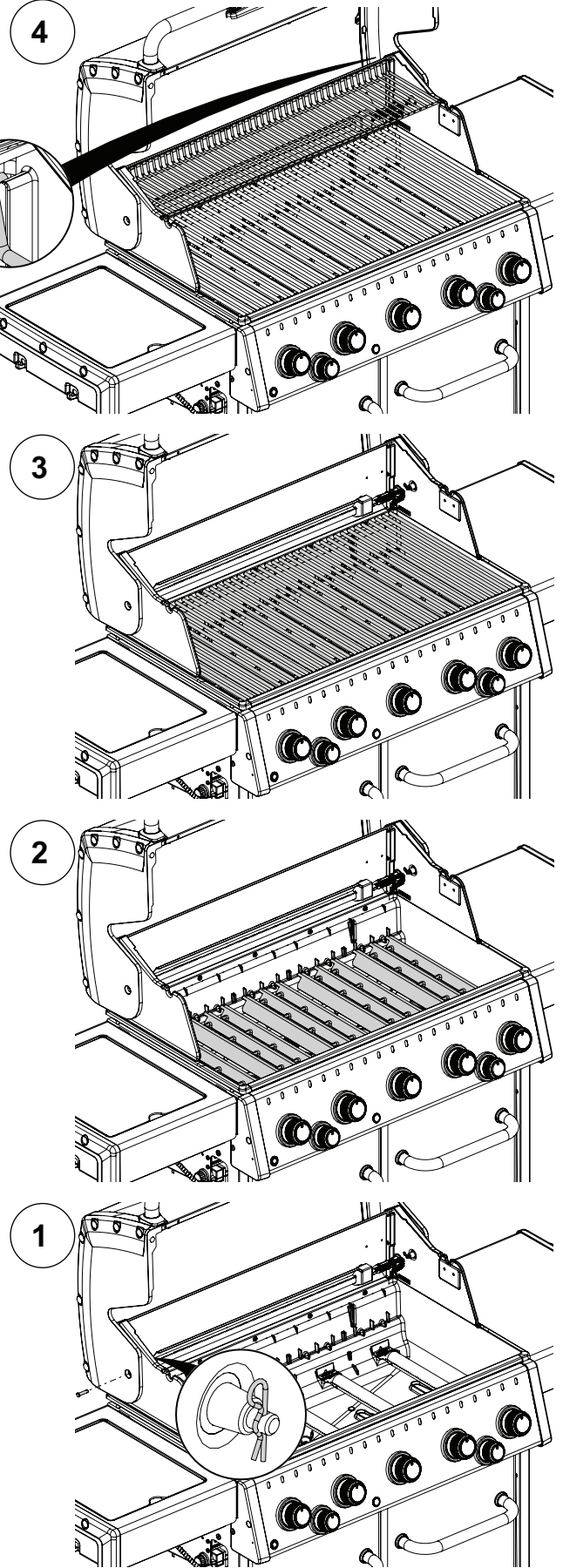
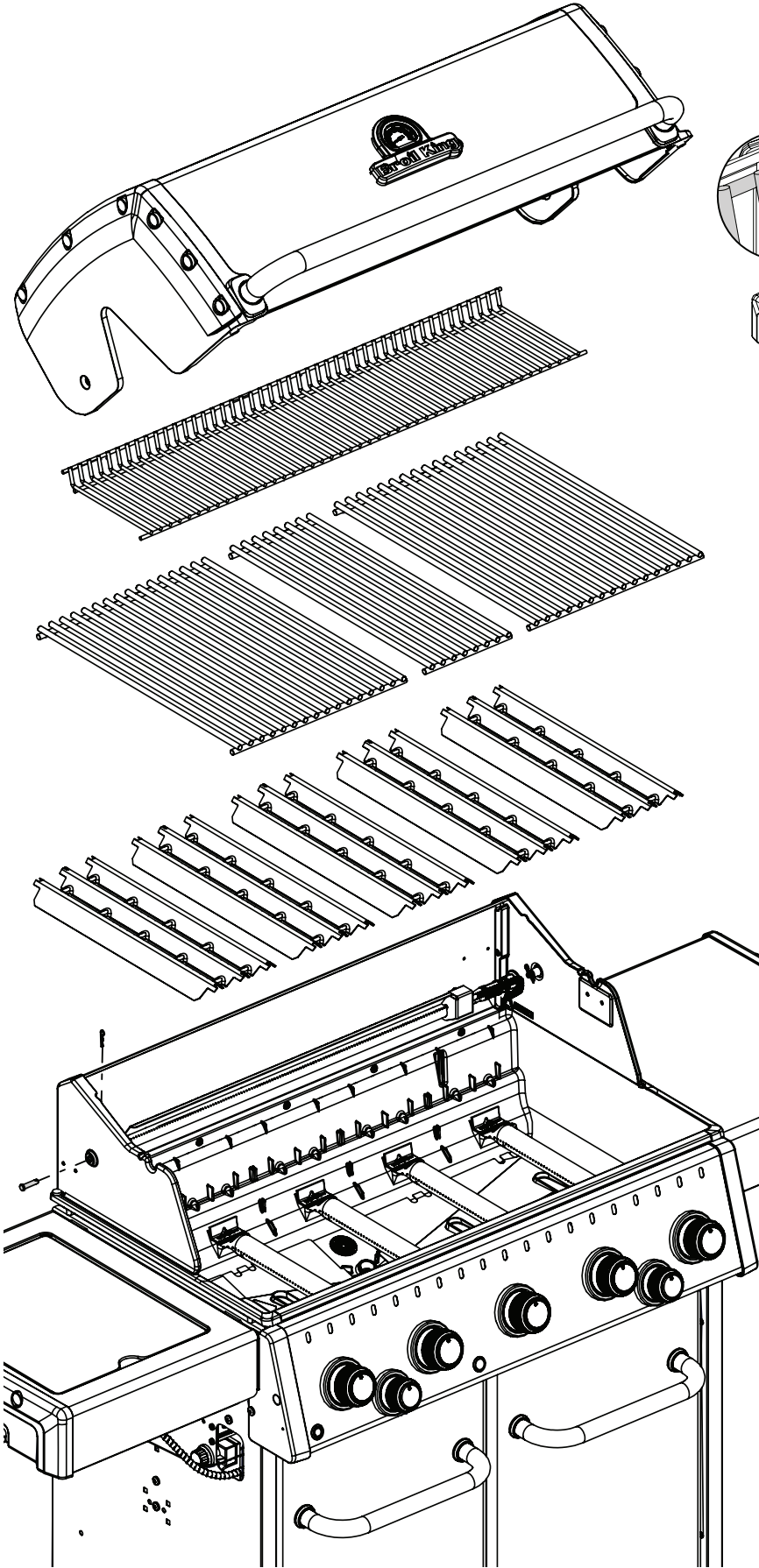
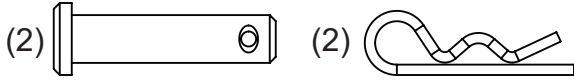

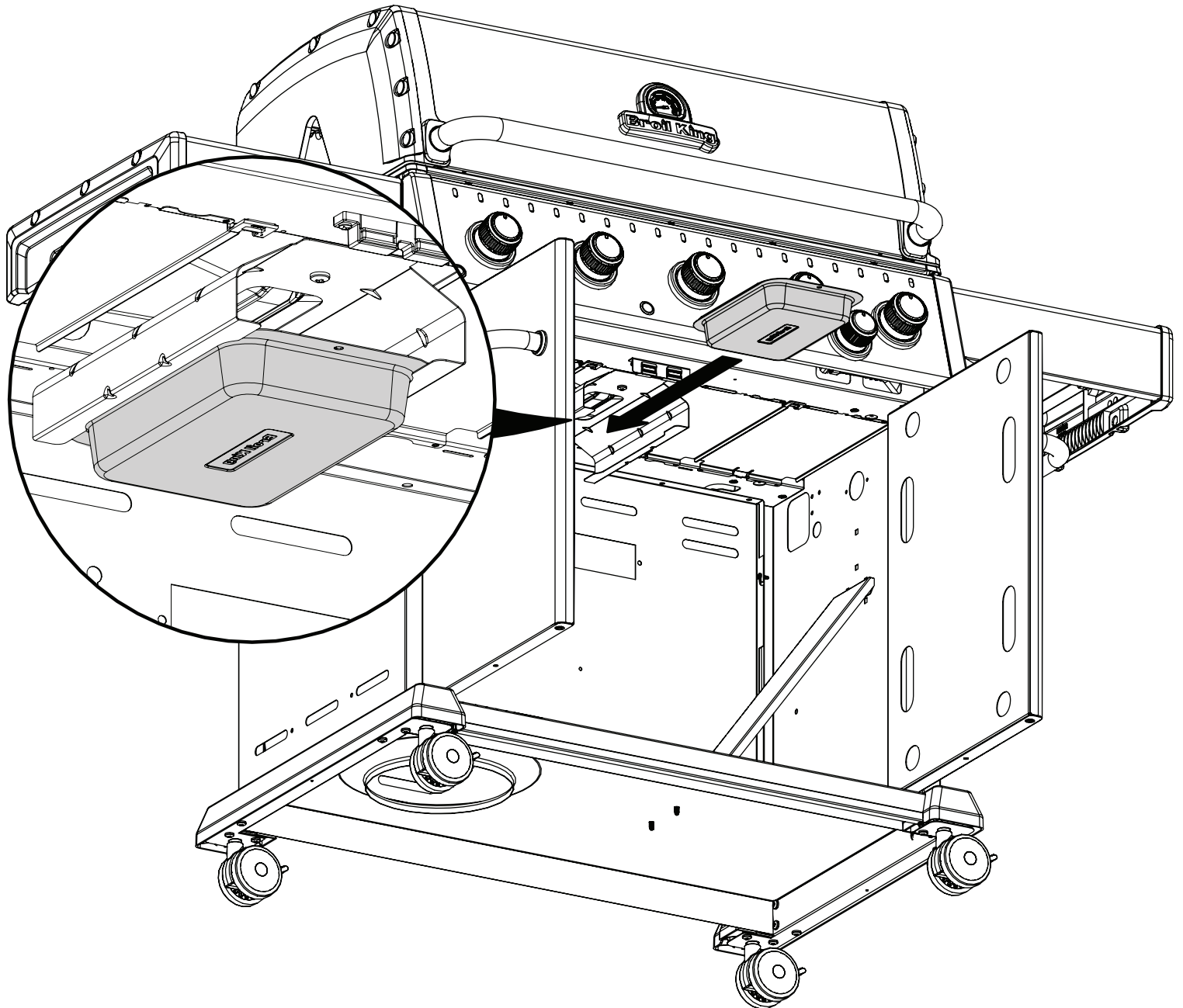
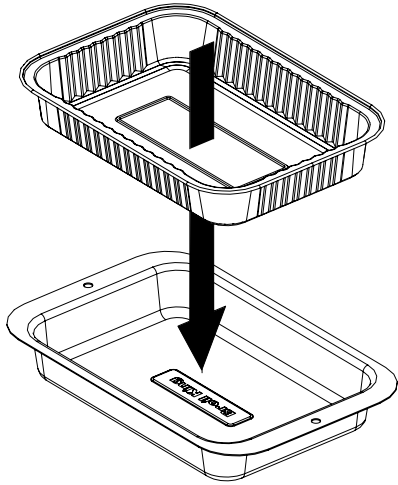

25

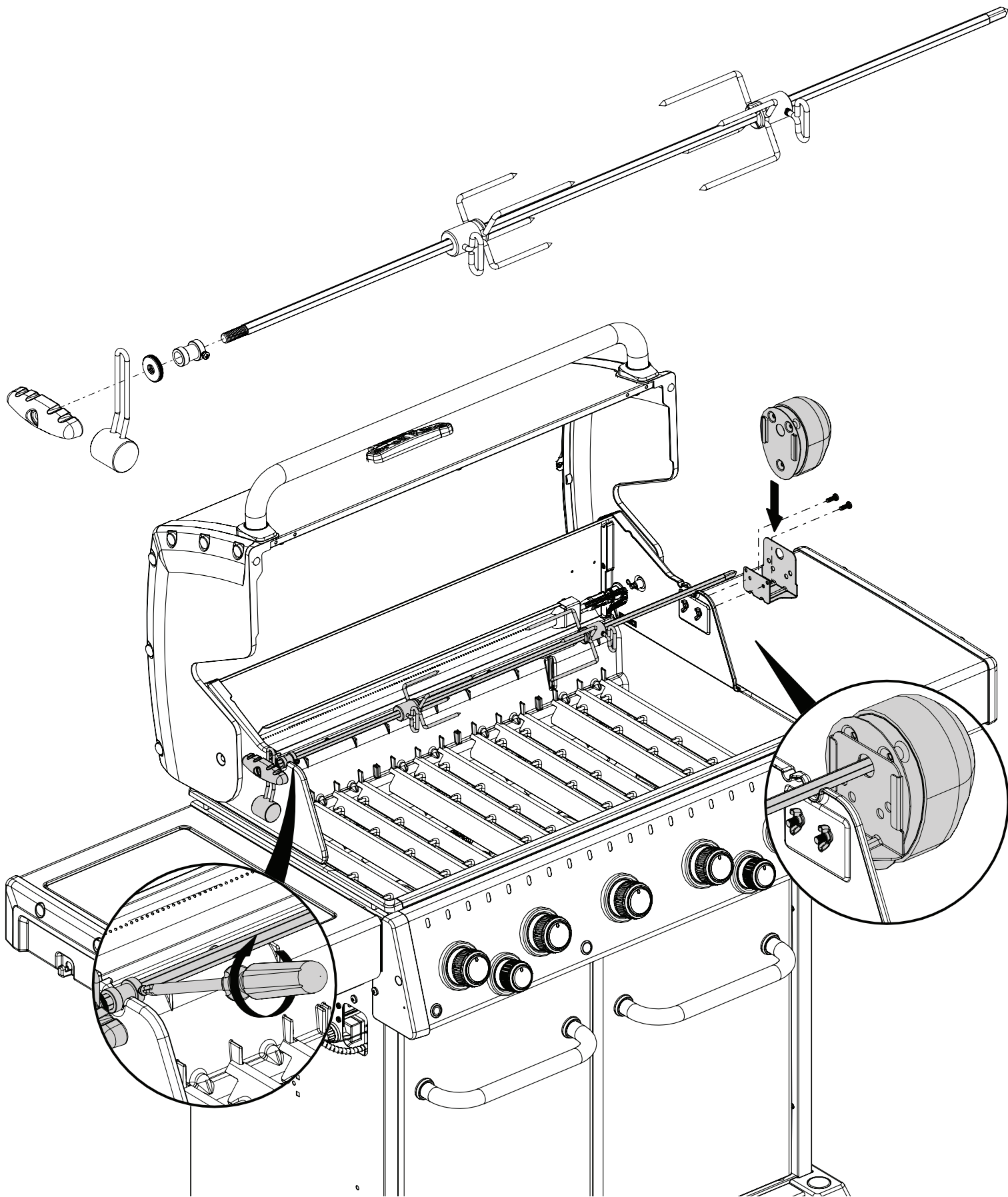
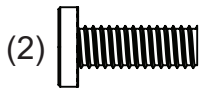

26

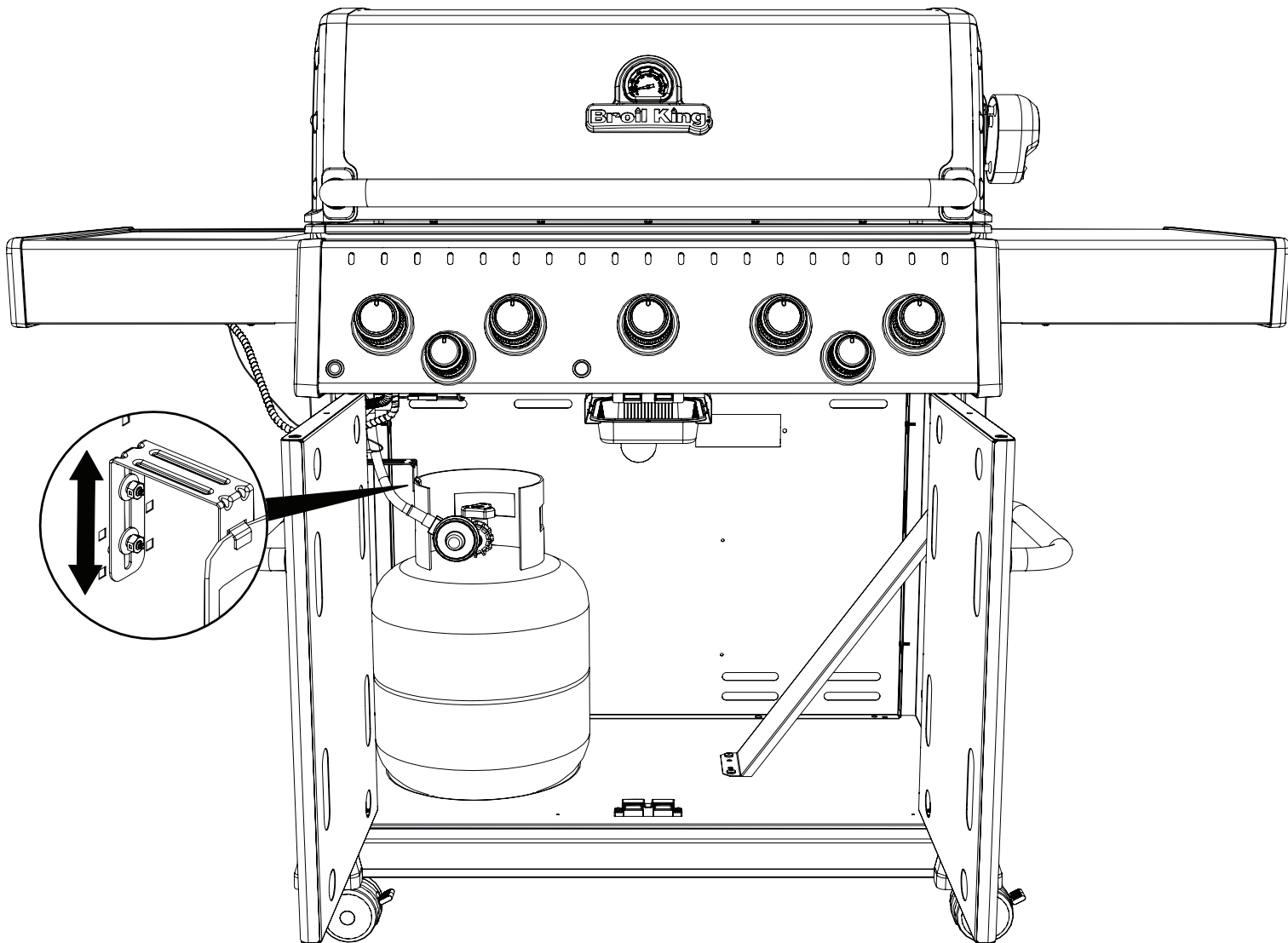
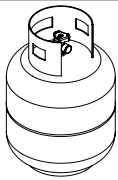

27

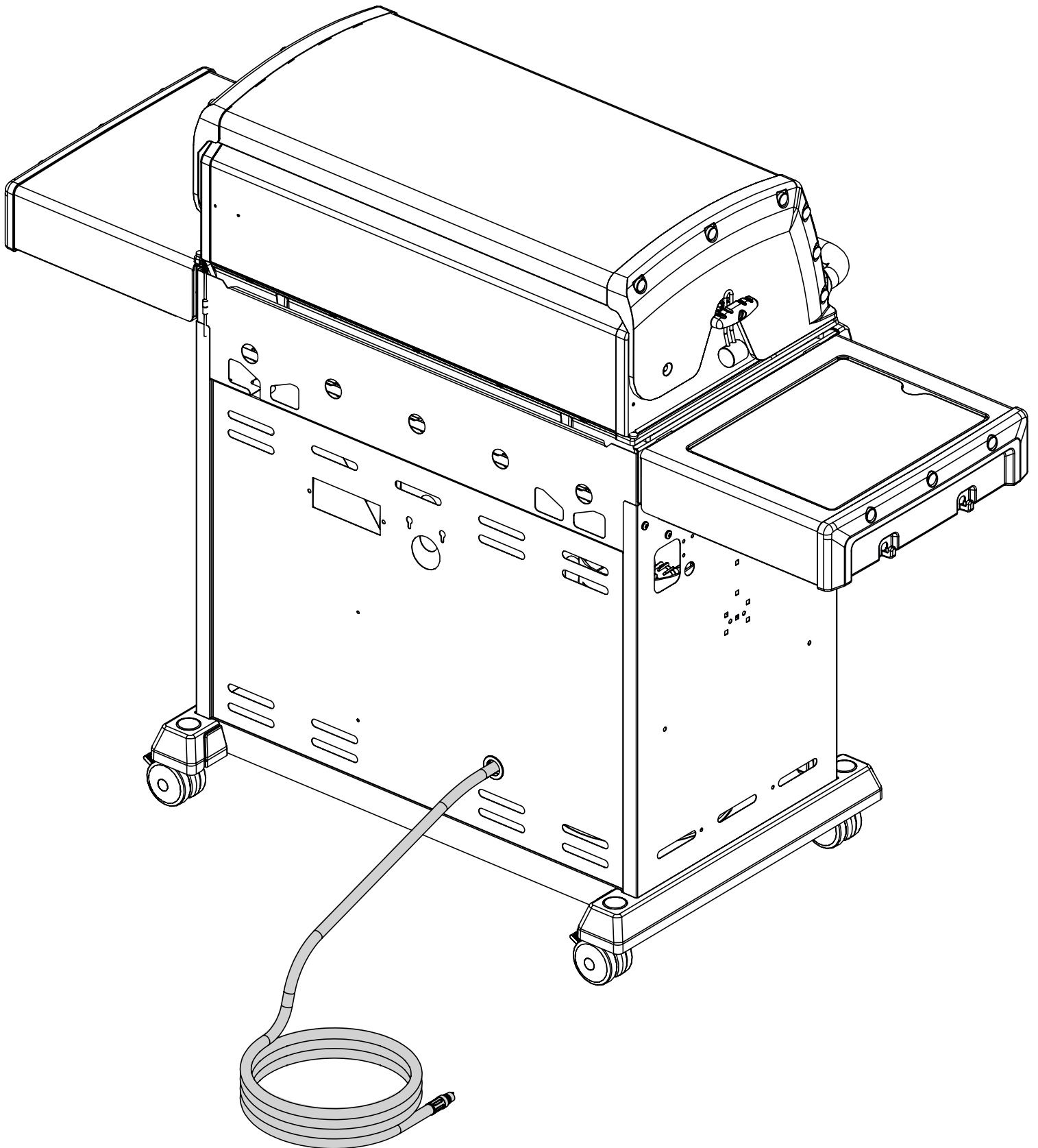

PARTS LIST / LISTE DES PIÈCES

<u>KEY #</u>	<u>ITEM #</u>	<u>DESCRIPTION</u>	<u>8762-14</u>	<u>8762-24</u>	<u>8762-44</u>	<u>8762-54</u>	<u>8762-84</u>	<u>8763-14</u>	<u>8763-24</u>	<u>8763-44</u>
			<u>8762-17</u>	<u>8762-27</u>	<u>8762-47</u>	<u>8762-57</u>	<u>8762-87</u>	<u>8763-17</u>	<u>8763-27</u>	<u>8763-47</u>
161	Y-12310	SCREW 1/4-20 X 3/4	8	8	8	8	8	8	8	8
163	S35094	SCREW #10-24 X 5/8	4	4	4	4	4	4	4	4
169	S21061	WING NUT	.	.	2	.	2	.	.	2
171	S15236	MOTOR	.	.	1	.	1	.	.	1
172	S15524	ELECTRODE	.	.	1	.	1	.	.	1
173	S21362	SPRING	.	.	1	.	1	.	.	1
174	S21255	WASHER	2/0	2/0	2/0	2/0	2/0	2/0	2/0	2/0
175	Y-11546	SCREW - 1/4:20 X 5/8	2/0	2/0	2/0	2/0	2/0	2/0	2/0	2/0
176	Y-11795	NUT 1/4-20	2/0	2/0	2/0	2/0	2/0	2/0	2/0	2/0
180	S35095	SCREW #10-24 X 5/8	.	.	2	.	2	.	.	2
181	25030-73	WIRE - BATTERY PACK	1	1	1	1	1	1	1	1
181A	25070-95	LIGHT SWITCH	1	1	1	1	1	1	1	1
184	25080-80	BATTERY PACK	1	1	1	1	1	1	1	1
186	Y-12865	SCREW 1/4-20 X 3/4	46 / 42	46 / 42	46 / 42	46 / 42	46 / 42	46 / 42	46 / 42	46 / 42
190	25020-83	WIRE - LED LIGHT	1	2	1	1	1	1	2	1
191	25020-82	WIRE - LED LIGHT	1	.	.	1	.	1	.	.
	25020-84	WIRE - LED LIGHT	.	.	1	.	1	.	.	1

