

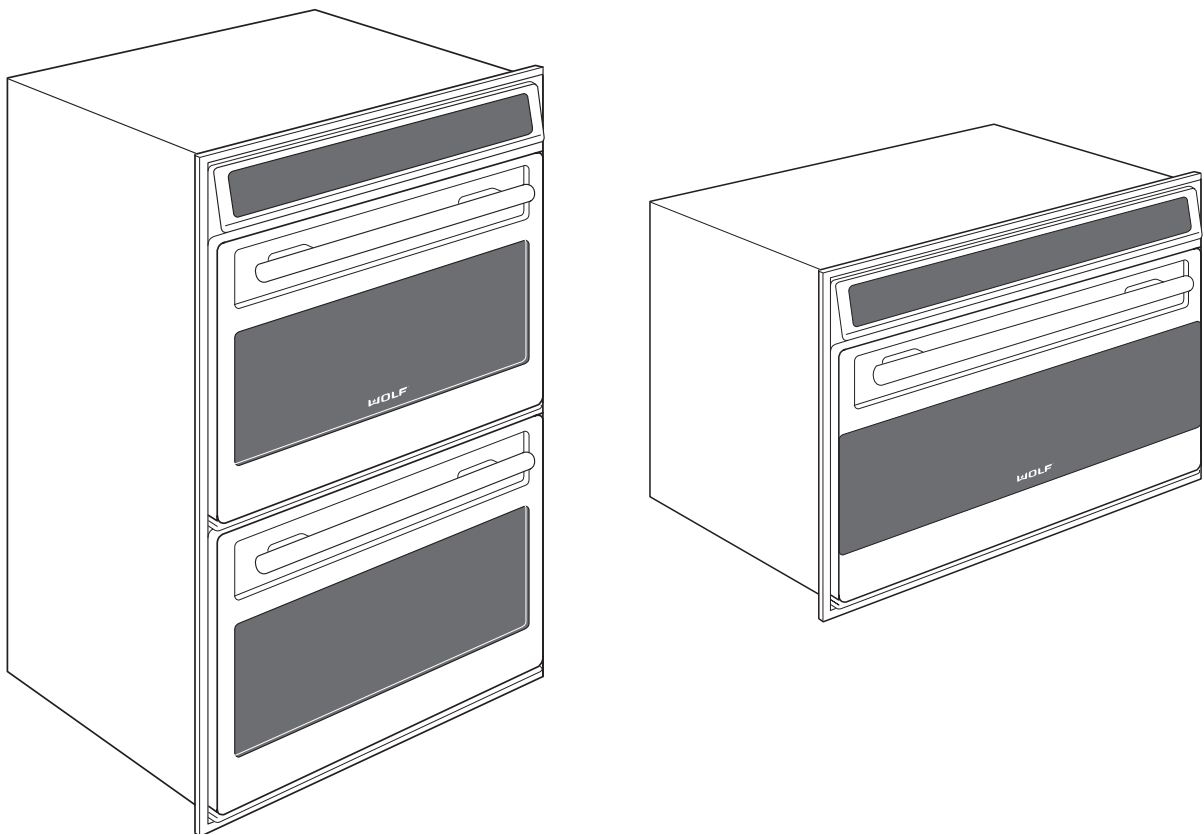

Wall Oven Series



Technical Service Manual Wall Oven-2 & Wall Oven-3

SECTION 1

GENERAL INFORMATION

INTRODUCTION

This Wolf Wall Oven Series Technical Service Manual, Part #806372, has been compiled to provide the most recent technical service information about the Wolf Wall Ovens produced after serial number 11100847. This information will enable the service technician to troubleshoot and diagnose malfunctions, perform necessary repairs and return a Wolf Wall Oven Series to proper operational condition.

The service technician should read the complete instructions contained in this service manual before initiating any repairs on a Wolf Appliance.

NOTE: Refer to the *Wall Oven-2 Series Service Parts Manual #806373* for part numbers and exploded views for units produced prior to serial number 16000000 and *Wall Oven-3 Series Service Parts Manual #807041* for units produced after serial number 16000000 .

IMPORTANT SAFETY INFORMATION

Below are the Product Safety Labels used in this manual. The "Signal Words" used are **WARNING** and **CAUTION**.

Please note that these safety labels are placed in areas where awareness of personal safety and product safety should be taken and lists the precautions to be taken when the signal word is observed.

⚠ WARNING

INDICATES THAT HAZARDOUS OR UNSAFE PRACTICES COULD RESULT IN SEVERE PERSONAL INJURY OR DEATH

⚠ CAUTION

Indicates that hazardous or unsafe practices could result in minor personal injury or product and/or property damage

In addition, please pay attention to the signal word **"NOTE"**, which highlights especially important information within each section.

TECHNICAL ASSISTANCE

If you should have any questions regarding a Wolf appliance and/or this manual, please contact:

Wolf Appliance Company, LLC
ATTN: Service Department
P.O. Box 44988
Madison, WI 53744-4988

Customer Service
Phone #: (800) 332 - 9513

Technical Assistance
Phone #: (800) 919 - 8324

Parts / Warranty Claims
Phone #: (800) 332 - 9513

Customer Service E-Mail Address
customerservice@wolfappliance.com

Customer Service & Technical Assistance
Facsimile #: (608) 441 - 5887

Parts / Warranty Claims
Facsimile #: (608) 441 - 5886

Office Hours:
7:00 AM to 7:00 PM Central Standard Time
Monday through Friday

This manual is designed to be used by Authorized Service Personnel only. Wolf Appliance Company, LLC. assumes no responsibility for any repairs made to Wolf appliances by anyone other than Authorized Service Technicians.

The information and images are the copyright property of Wolf Appliance Company, LLC, an affiliate of Sub-Zero Freezer Company, Inc. Neither this manual nor any information or images contained herein may be copied or used in whole or in part without the express written permission of Wolf Appliance Company, LLC, an affiliate of Sub-Zero Freezer Company, Inc. © Wolf Appliance Company, LLC all rights reserved.

TABLE OF CONTENTS

	Page #		Page #
Section 1 - General Information		Section 3 - Electronic Control System (Continued)	
Introduction.....	1-2	Initiating Diagnostic Mode.....	3-20
Important Safety Information.....	1-2	Possible Error Indicators.....	3-21
Technical Assistance.....	1-2	Testing The Oven Relay Board.....	3-24
Table of Contents.....	1-3	Element Testing.....	3-24
Table of Contents.....	1-4	Fan and Motor Testing.....	3-25
Warranty Information.....	1-5	RTD Testing.....	3-25
Serial Tag Location.....	1-5	Temperature Probe Testing.....	3-25
Model Number Key.....	1-6		
Model Configurations.....	1-7	Section 4 - Component Access and Removal	
Model Configurations.....	1-8	Important Warnings.....	4-2
Oven Features.....	1-9	Control Panel Components.....	4-3
		Control Panel Assembly.....	4-3
Section 2 -Installation Information		Control Panel Drive Motor.....	4-3
Electrical Requirements.....	2-2	C-Channel Top and Bottom.....	4-4
Minimum Wire Size.....	2-2	Switch Actuator and Plunger.....	4-4
Oven Installation.....	2-3	Components Behind the Control Panel.....	4-5
Trim Installation.....	2-3	Latch Cover.....	4-5
Wall Oven Dimensions.....	2-4	Motor Door Lock.....	4-5
Cabinet Cutout Dimensions.....	2-5	Limit Switch.....	4-5
SO30.....	2-5	Oven Control Board.....	4-6
SO36.....	2-6	Stepper Motor Control Board.....	4-6
DO30.....	2-7	Relay Board.....	4-7
Side-by-Side.....	2-8	Light Transformer.....	4-7
		Light Fuse.....	4-7
Section 3 - Electronic Control System		Upper Cooling Fan.....	4-8
Electronic Control Terminology and Component		Terminal Block.....	4-8
Descriptions.....	3-2	Oven Cavity Components.....	4-9
Unique Electronic Control Input Operations.....	3-3	Left and Right Rack Guide.....	4-9
Field Option Mode.....	3-3	Oven Lights.....	4-9
User Preference Offset.....	3-3	Convection Baffle Plate.....	4-9
Temperature Display Preference.....	3-3	Probe Cover and Probe Switch.....	4-10
Clock Display Preference.....	3-3	Temperature Sensor.....	4-10
Sabbath Feature.....	3-4	Convection Fan.....	4-11
Time Cook Feature.....	3-5	Broil Element and Broil Pan.....	4-11
Delayed Start Feature.....	3-6	Smoke Catalyst.....	4-11
Temperature Probe Mode.....	3-7	Bake Stone.....	4-12
USDA Internal Temperature		Oven Door Components.....	4-13
Recommendations Chart.....	3-7	Oven Door.....	4-13
Self-Clean Mode.....	3-8	Door Adjustments.....	4-13
Electronic Control Input Operations.....	3-9	Door Gasket.....	4-13
Bake Mode.....	3-9	Outer Door Skin.....	4-13
Convection Mode.....	3-10	Glass Pack.....	4-14
Convection Bake Mode.....	3-11	Hinge.....	4-14
Broil Mode.....	3-12	Hydraulic Hinge.....	4-14
Convection Broil Mode.....	3-13	Components Behind the Back Panel.....	4-15
Roast Mode.....	3-14	Back Panel.....	4-15
Convection Roast Mode.....	3-15	Divider Channels.....	4-15
Bake Stone Mode.....	3-16	Lower Cooling Fan.....	4-15
Dehydrate Feature.....	3-17	Bake Element.....	4-15
Proof Feature.....	3-18	Oven Side Components.....	4-16
Panel Lock.....	3-19	Channel Venting.....	4-16
Time of Day Clock.....	3-19	Hinge Pocket.....	4-16
Diagnostics Mode.....	3-19	Enclosure.....	4-16
Double Wall Oven Keyboard.....	3-19	Insulation.....	4-16
Single Wall Oven Keyboard.....	3-19		

Section 5 -Troubleshooting Guide

General Troubleshooting Guide Layout.....5-2
Troubleshooting Guide Table of Contents.....5-2
Initiating Diagnostic Mode.....5-3
Error Code Chart.....5-4
Testing The Oven Relay Board.....5-5
Element Testing.....5-5
 Ohm Testing Elements at the Relay Board.....5-5
 Fans and Motors.....5-6
RTD Testing.....5-6
Probe Testing.....5-6
Troubleshooting Guides.....5-7
Troubleshooting Flow Chart.....5-9
Head Assembly Doesn't Rotate Flow Chart.....5-10

Section 6 -Technical Data

Technical Data Chart.....6-2
Operation Time Chart.....6-3

Section 7 -Wiring Diagrams

DO30 Wiring Diagram.....7-2
DO30 Schematic.....7-3
SO30 - SO36 Wiring Diagram.....7-4
SO30 - SO36 Schematic.....7-5
SO30 Schematic (SWS 16000000).....7-6
DO30 Schematic (SWS 16000000).....7-7

WARRANTY INFORMATION

This page contains a summary of the 2 & 5 Year Warranty that is supplied with every Wolf product, followed by details and notes about the warranties.

TWO & FIVE YEAR Warranty Summary

- Two year TOTAL PRODUCT warranty, *parts and labor.
- Limited Parts Only Warranty for the 3rd through 5th year on the following parts only:
 - Electric heating elements
 - Electronic Control Boards

Warranty Details:

The warranty applies only to products installed for normal residential use. The warranty applies only to product installed in the United States or Canada.

Warranty Notes:

- All warranties begin at the time of the unit's initial installation.
- All Warranty and Service information collected by Wolf Appliance Company, LLC. is arranged and stored under the unit serial number and/or the customer's name. Please note that Wolf Appliance Company LLC. requests that you have the model serial number available whenever contacting the factory or parts distributor.
- See Figure 1-1 for serial tag layout.
- See Figure 1-2 for serial tag location.

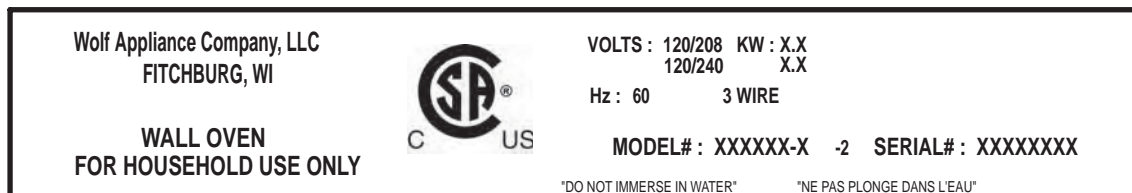

Figure 1-1. Typical Serial Tag Layout

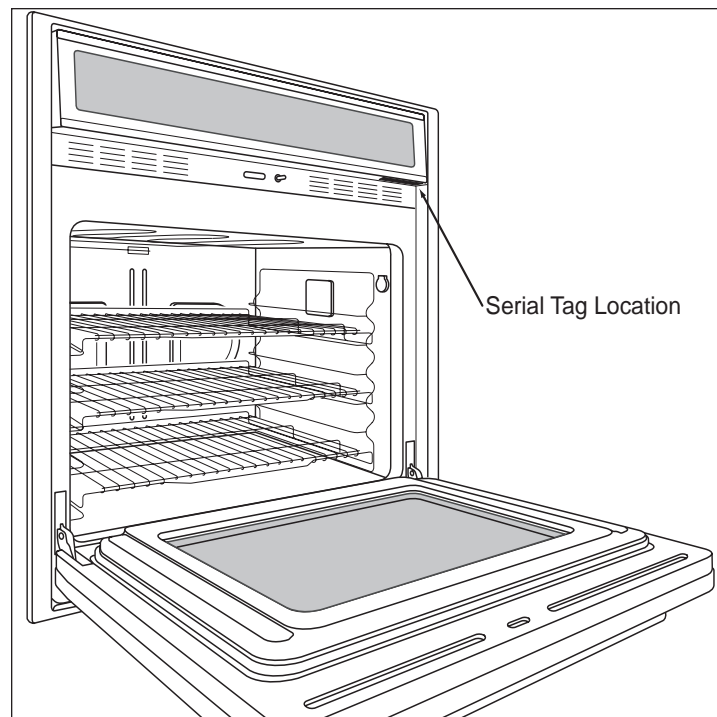
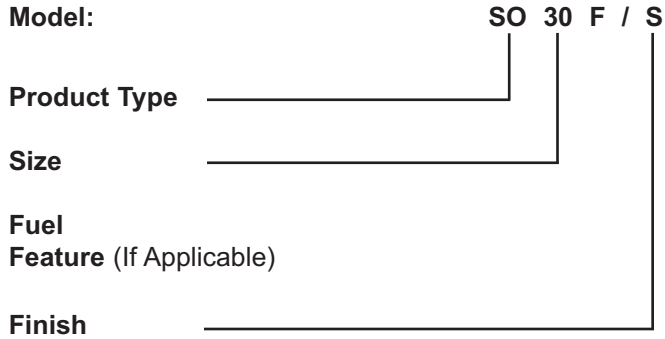

Figure 1-2. The serial tag is located underneath the control panel.

MODEL NUMBER KEY

Refer to this key for an example of the model numbers.



Product Type

- SO Single Oven
- DO Double Oven
- CT Cooktop

Size

- 30 30 - inch wide unit
- 36 36 - inch wide unit

Fuel

- E Electric

Oven Door

- F Framed
- U Unframed

Finish

- S Classic Stainless Steel
- P Platinum Stainless Steel
- B Carbon Stainless Steel

MODEL CONFIGURATIONS

Single Ovens

30" Single Oven Framed

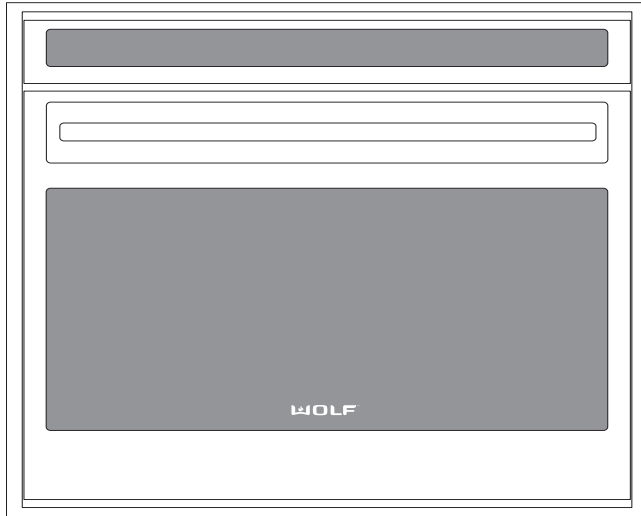

Model Number	Description
SO30F/S	Single Oven 30" Framed Stainless

36" Single Oven Unframed



Model Number	Description
SO36U/S	Single Oven 36" Unframed Stainless
SO36U/P	Single Oven 36" Unframed Platinum
SO36U/B	Single Oven 36" Unframed Carbon



Model Number	Description
SO30U/S	Single Oven 30" Unframed Stainless
SO30U/P	Single Oven 30" Unframed Platinum
SO30U/B	Single Oven 30" Unframed Carbon

Double Ovens

30" Double Oven Framed

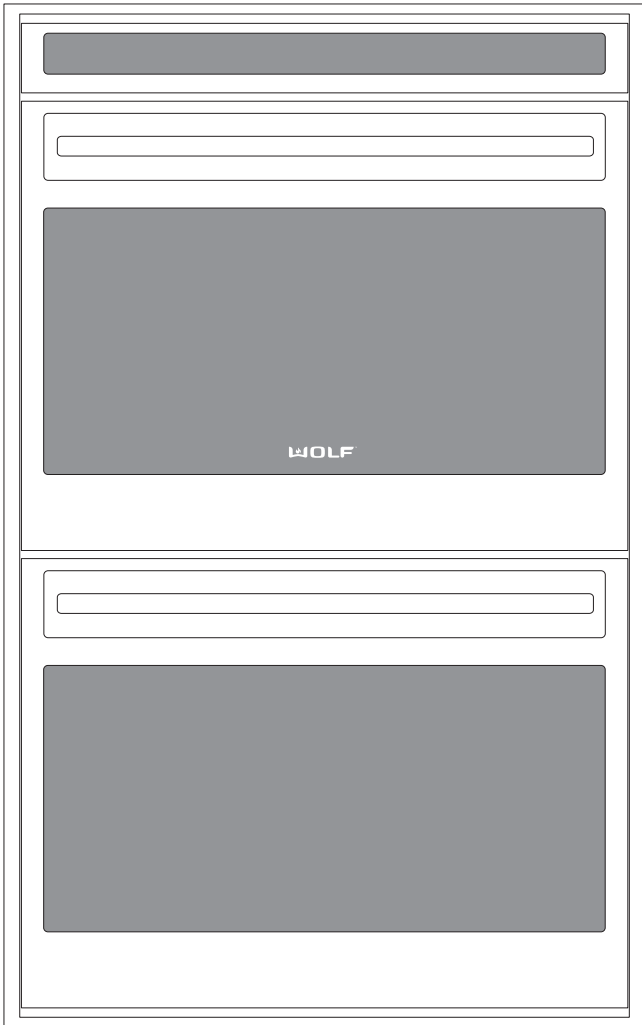

30" Double Oven Unframed

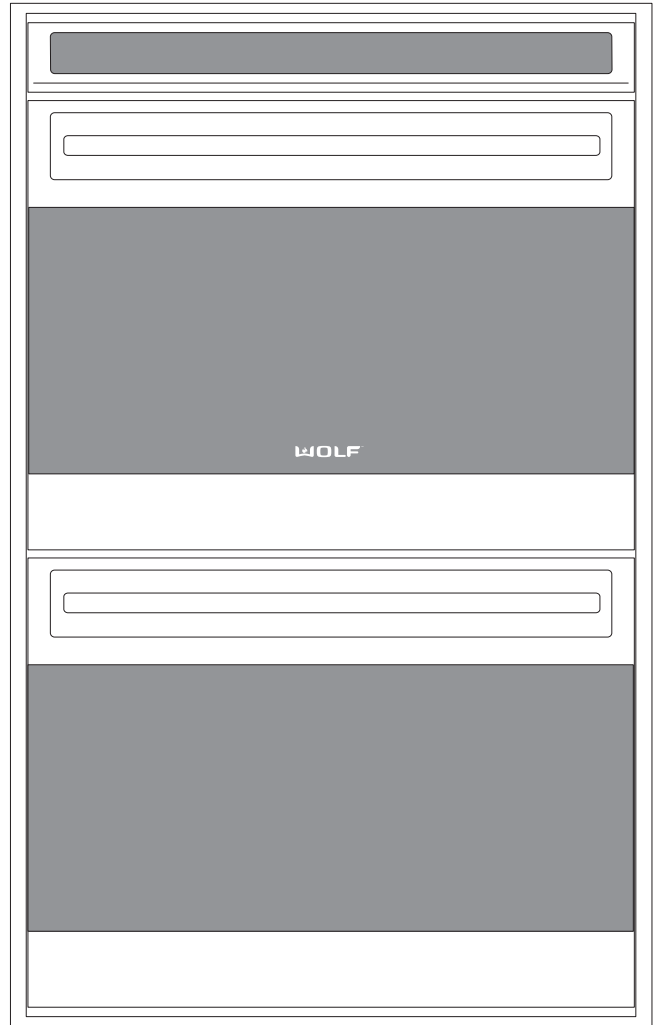

Model Number	Description
DO30F/S	Double Oven 30" Framed Stainless

Model Number	Description
DO30U/S	Double Oven 30" Unframed Stainless
DO30U/P	Double Oven 30" Unframed Platinum
DO30U/B	Double Oven 30" Unframed Carbon

OVEN FEATURES

- Two door styles
 - Traditional Framed (30")
 - Contemporary Unframed (30" & 36")
- Framed door finish
 - Classic Stainless Steel
- Unframed door finishes
 - Classic Stainless Steel
 - Platinum Stainless Steel
 - Carbon Stainless Steel
- Dual Convection Logic Control System
- Rotating Control Panel
- Touch Control Panel
- Door Hinge with Hydraulic Damper System
- Large Viewing Window
- Triple Pane Window
- Dual Halogen Lighting
- Temperature Probe and Receptacle
- Six Level Rack Guide
- Full Extension Bottom Rack
- Hidden Bake Element
- Broil Element
- Bake Mode
- Convection Mode
- Convection Bake Mode
- Broil Mode
- Convection Broil Mode
- Roast Mode
- Convection Roast Mode
- Bake Stone Mode (Bake Stone Optional)
- Dehydrate Feature (Dehydrate Kit Optional)
- Proof Feature
- Self-Clean Mode
- Sabbath Mode

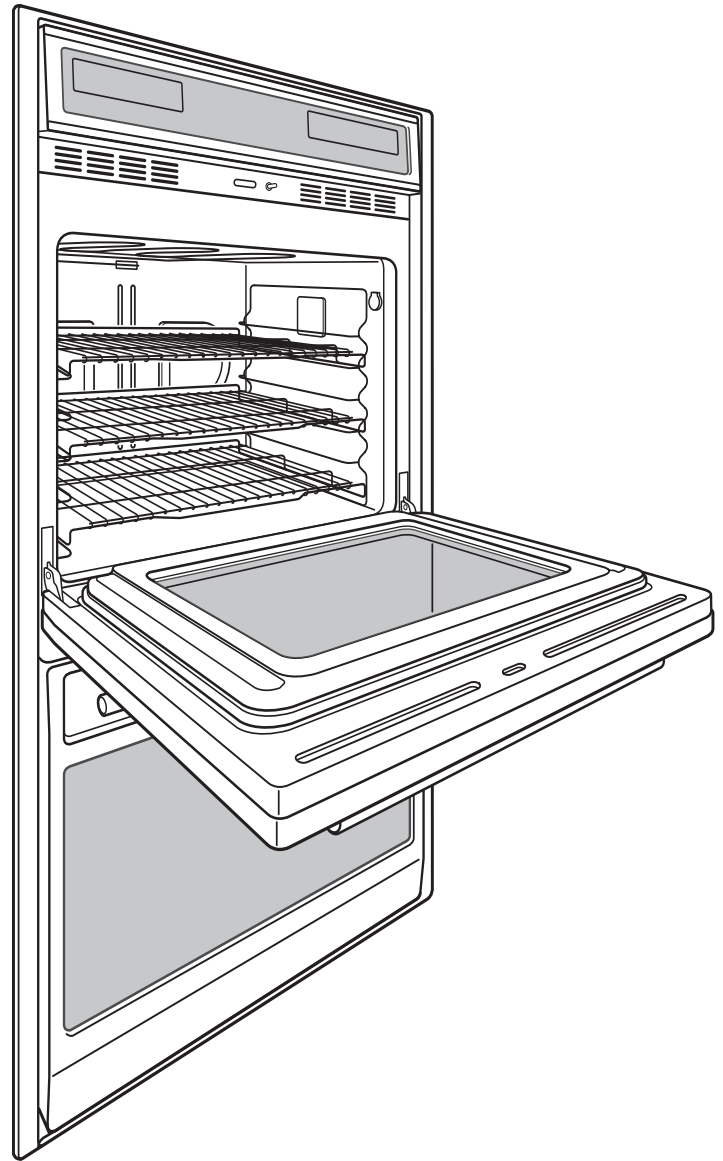

SECTION 2

INSTALLATION INFORMATION

INSTALLATION INFORMATION

This section of the manual covers some of the installation issues a service technician may need to know when servicing a Wolf Wall Oven. If additional information is needed after reviewing this section of the manual, please refer to the Installation Guide or contact the Wolf Appliance Customer Service Department.

Electrical Requirements:

Single Oven

- 208/220-240 volts AC, 60 Hertz, 30 Ampere fused electrical supply.

Double Oven

- 208/220-240 volts AC, 60 Hertz, 50 Ampere fused electrical supply.

Minimum Wire Size:

- L1, L2 and Ground: 10 AWG
- Neutral: 12 AWG

This appliance must be properly grounded. This appliance is equipped with a 60" conduit consisting of two insulated hot lead copper conductors, one insulated neutral copper conductor and one uninsulated ground copper conductor.

⚠ WARNING

THIS APPLIANCE MUST BE PROPERLY GROUNDED AT ALL TIMES WHEN ELECTRICAL POWER IS APPLIED.

DO NOT GROUND THE APPLIANCE WITH THE NEUTRAL (WHITE) HOUSE SUPPLY WIRE. A SEPERATE GROUND WIRE MUST BE UTILIZED.

IF ALUMINUM HOUSE SUPPLY WIRING IS UTILIZED, SPLICE THE APPLIANCE COPPER WIRE TO THE ALUMINUM HOUSE WIRING USING SPECIAL CONNECTORS DESIGNED AND CERTIFIED FOR JOINING COPPER AND ALUMINUM. FOLLOW THE CONNECTORS MANUFACTURERS RECOMMENDED PROCEDURE CAREFULLY. IMPROPER CONNECTION CAN RESULT IN A FIRE HAZARD.

Oven Installation

Use the upper edge of the cavity opening and the bottom of the oven chassis side as gripping points to lift the oven into the cabinet cutout. Slide the oven into the recessed area until the unit is approximately six inches from being fully installed. This will allow for installation of the oven trim kit.

NOTE: The oven door(s) may be removed to reduce the weight of the oven when lifting into cabinet opening.

⚠ CAUTION

Do not lift or carry the oven door(s) by the door handle.

Trim Installation

Attach the left and right side trim to the bottom and middle trim prior to installing on the oven. (See Figure 2-1).

NOTE: The middle trim is for double ovens only.

Peel off the adhesive backing on the flat washers. Attach the flat washers centered over the holes of the raised sides of the oven cavity frame.

NOTE: Four washers for single oven and eight washers for double oven.

Install the trim to the oven using the screws provided in the trim kit. Now, locate the mounting holes found on the sides of the oven trim. Then, use a drill with a 1/16" drill bit and drill four pilot holes for the cabinet mounting screws. Install the mounting screws through the oven side trim and into the cabinet. (See figure 2-2).

NOTE: Do not overtighten the mounting screws.

⚠ WARNING

FAILURE TO INSTALL THE MOUNTING SCREWS MAY RESULT IN MOVEMENT OR TIPPING OF THE OVEN DURING USE.

⚠ CAUTION

Do not block the oven air exhaust located at the bottom of the oven. Blocking the exhaust may result in cabinet damage and poor baking performance.

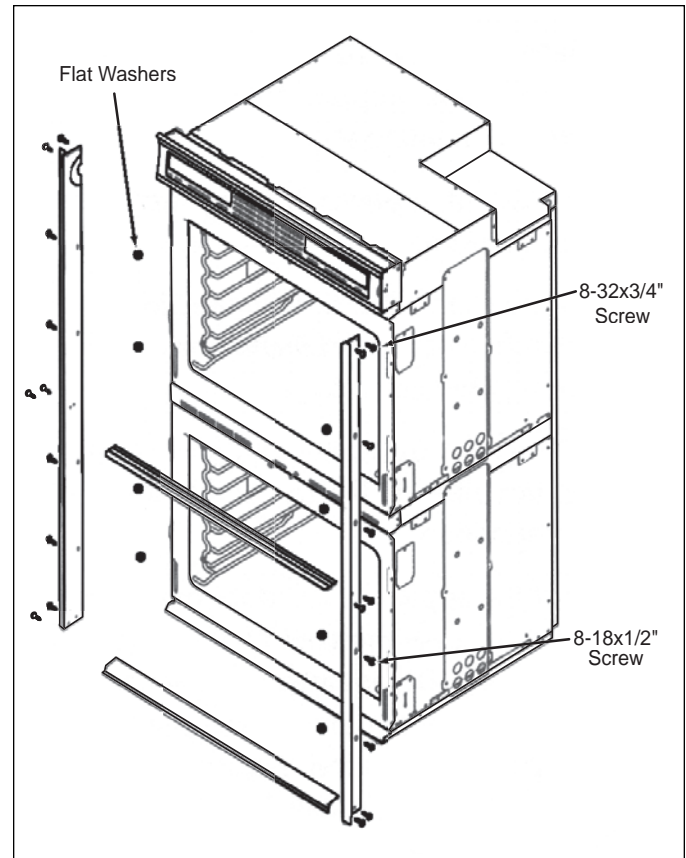

Figure 2-1. Trim Installation

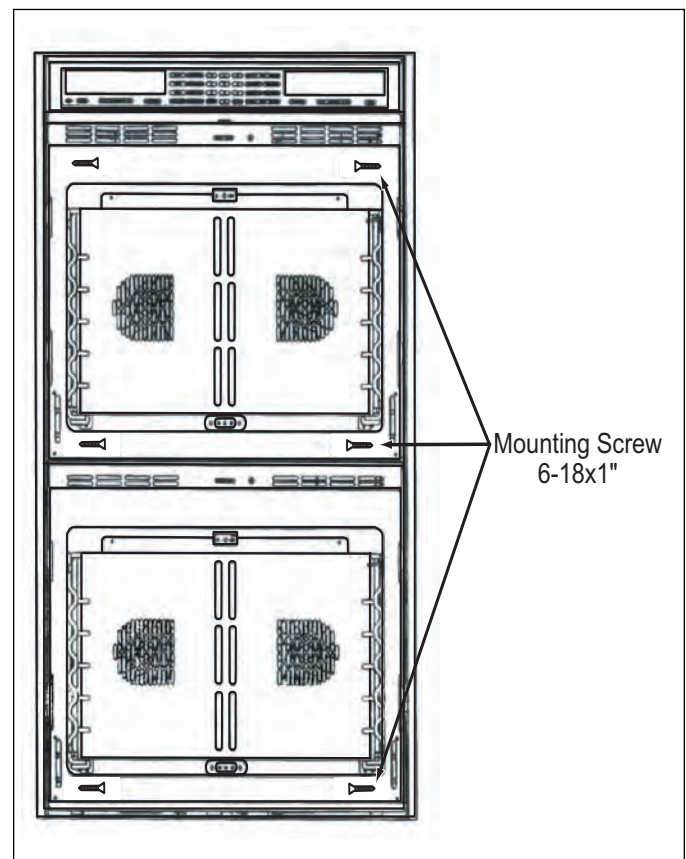

Figure 2-2. Cabinet Mounting Screws

WALL OVEN DIMENSIONS

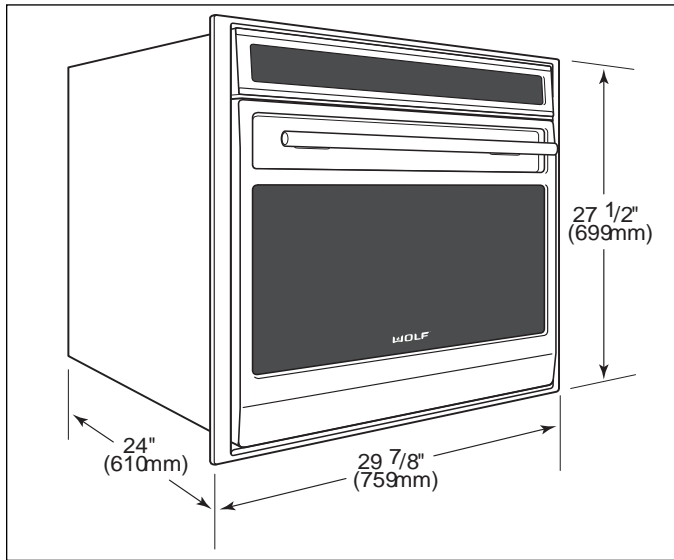

Figure 2-3. 30" Single Oven Overall Dimensions

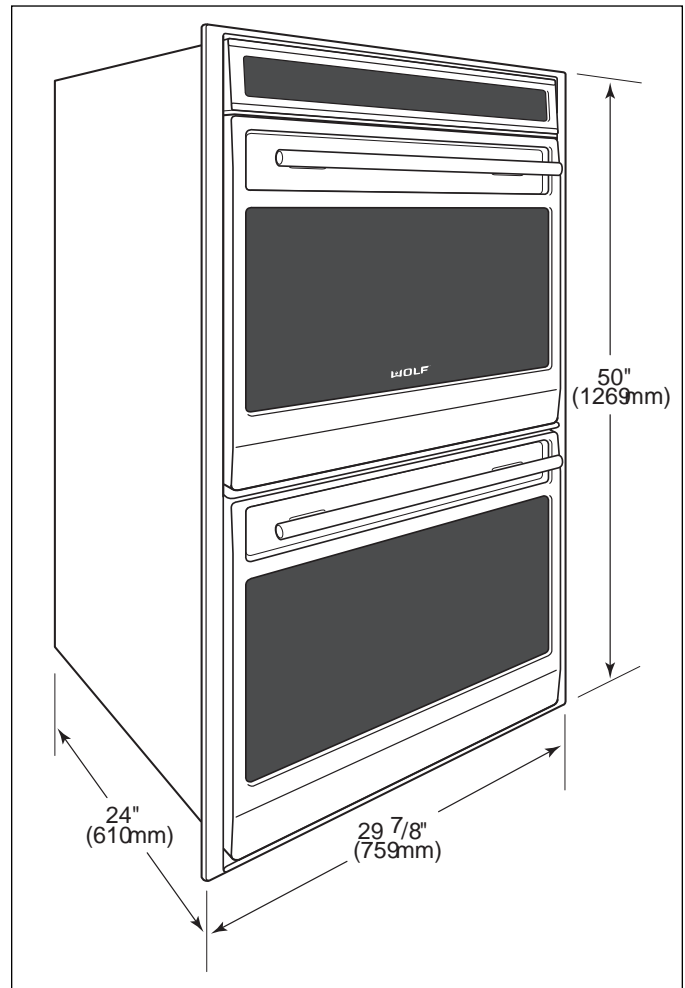

Figure 2-5. 30" Double Oven Overall Dimensions

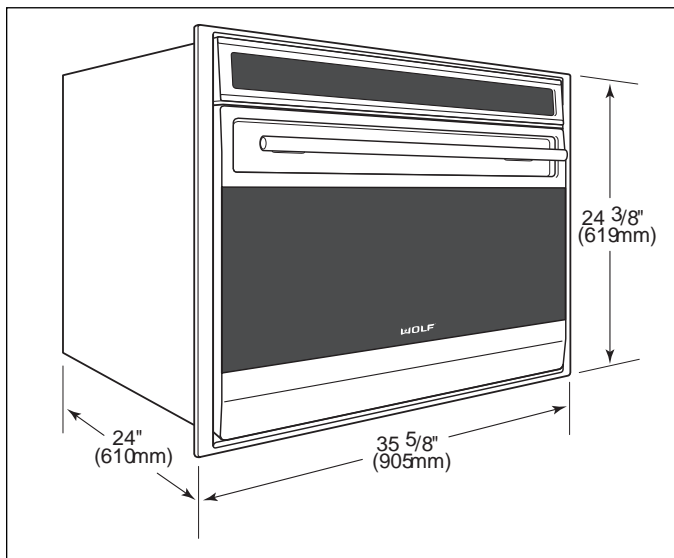

Figure 2-4. 36" Single Oven Overall Dimensions

CABINET CUTOUT DIMENSIONS

Single 30 Inch Wall Oven

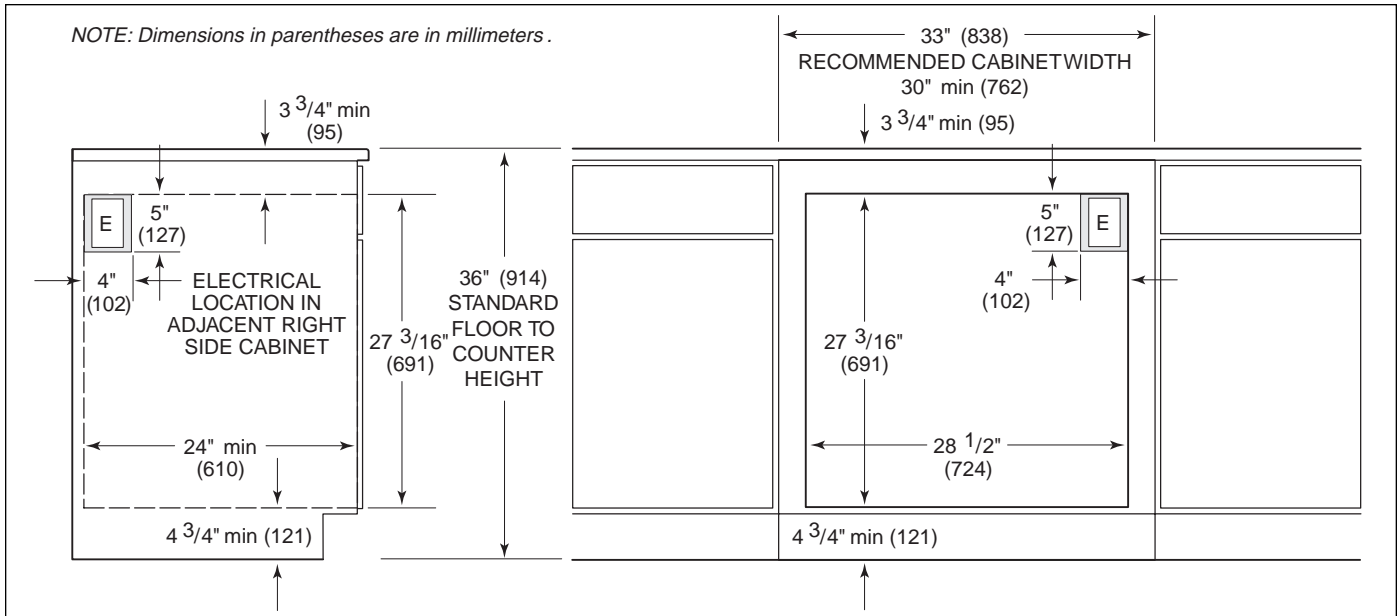

Figure 2-6. Undercounter Cutout Dimensions and Electrical Placement

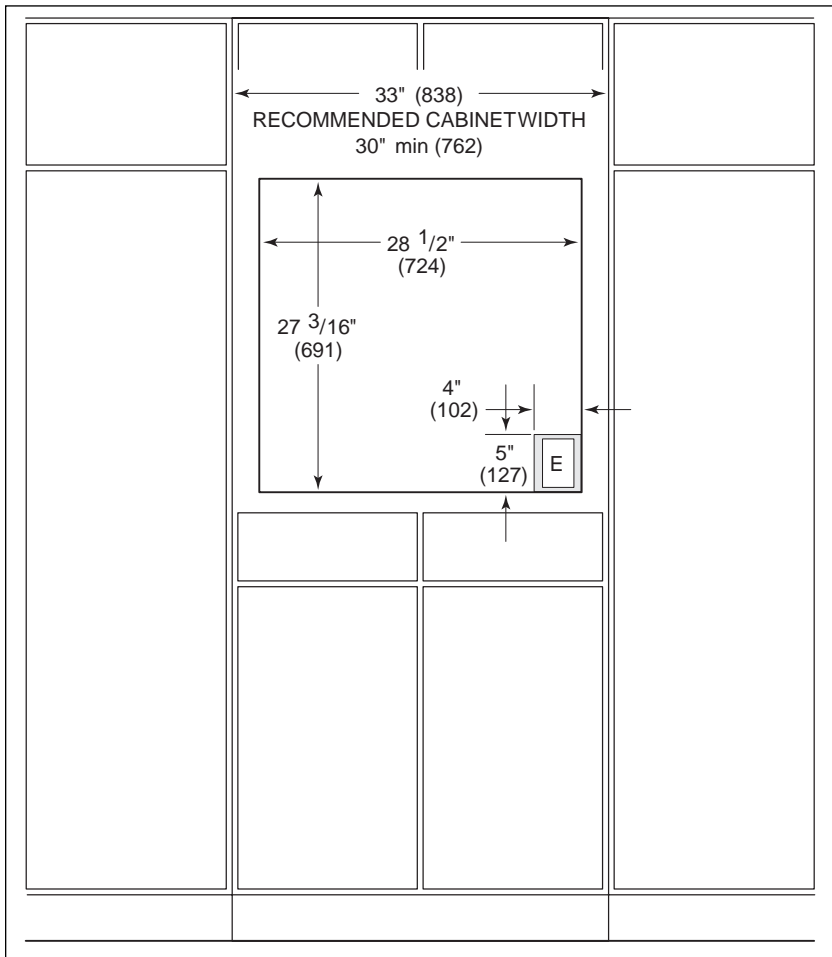

Figure 2-7. Front Cutout Dimensions and Electrical Placement

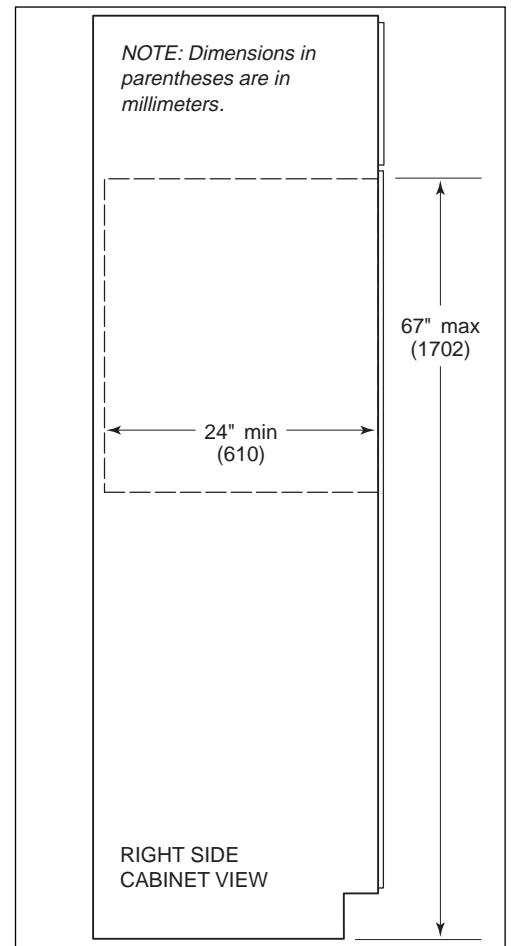

Figure 2-8. Side View

CABINET CUTOUT DIMENSIONS

Single 36 Inch Wall Oven

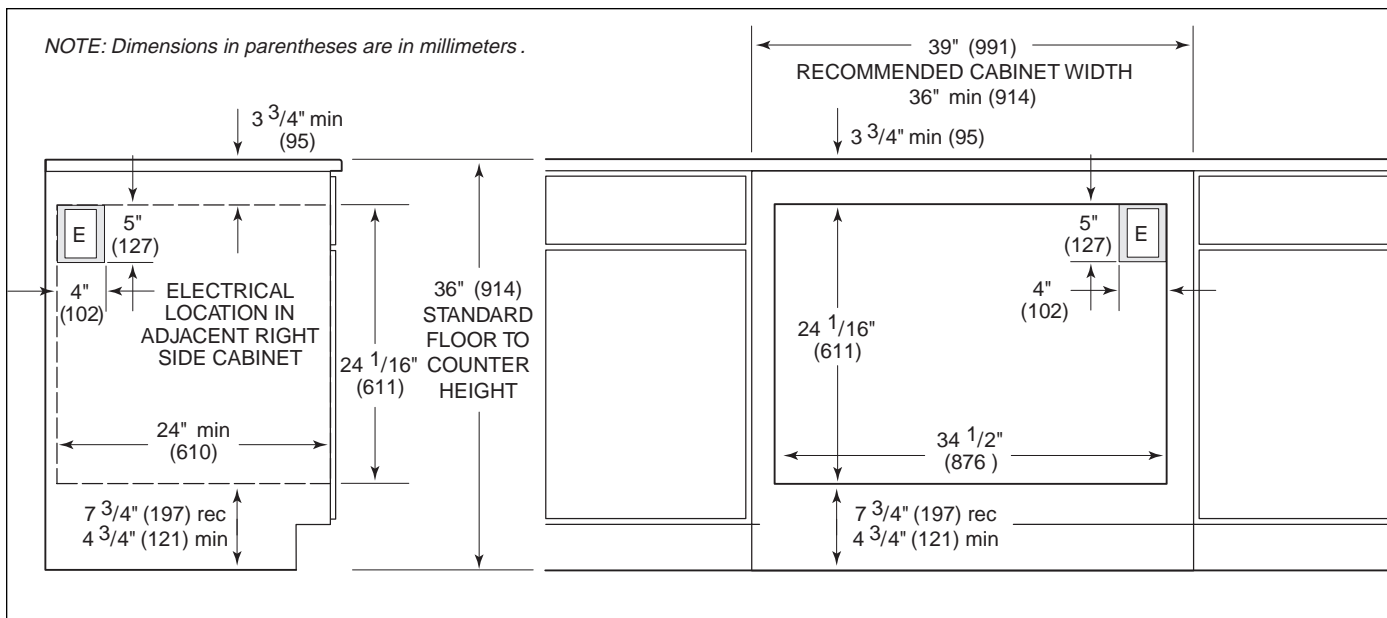

Figure 2-9. Undercounter Cutout Dimensions and Electrical Placement

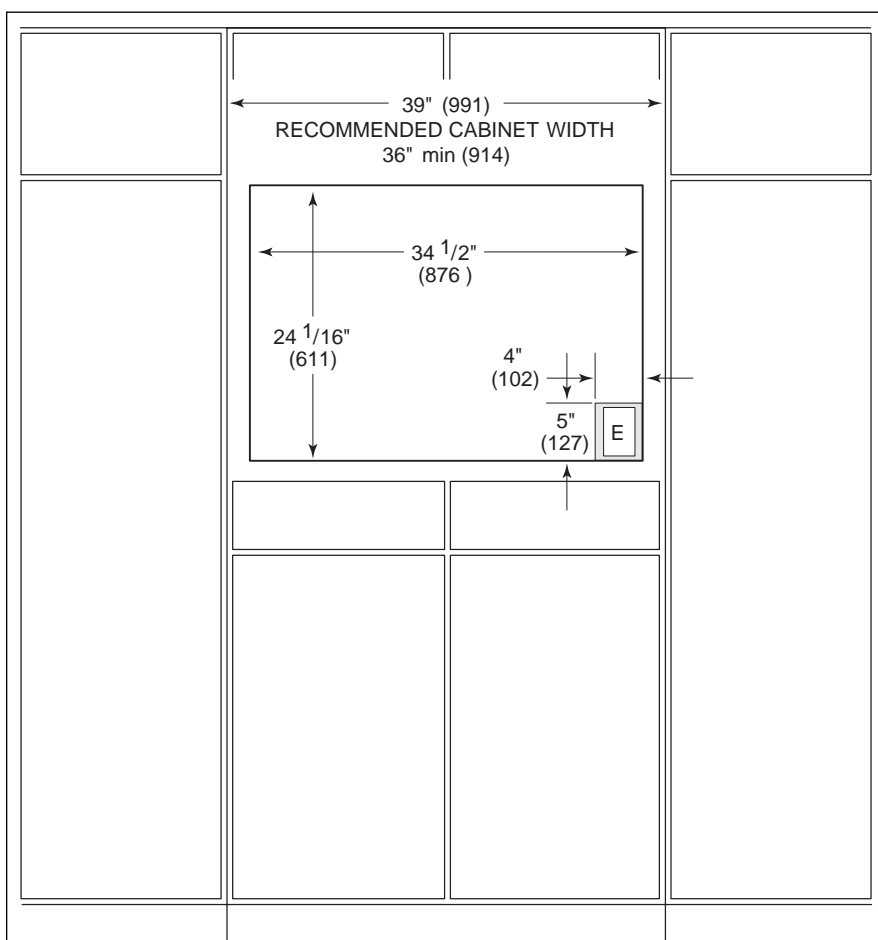

Figure 2-10. Front Cutout Dimensions and Electrical Placement

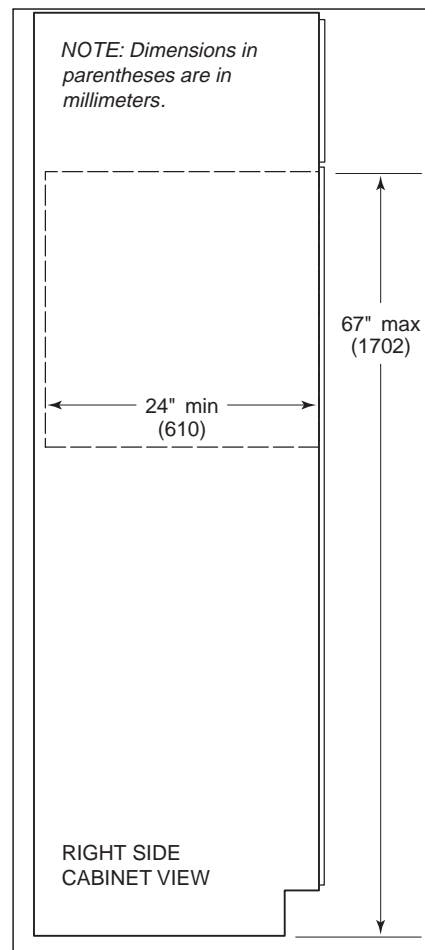

Figure 2-11. Side View

CABINET CUTOUT DIMENSIONS

Double 30 Inch Wall Oven

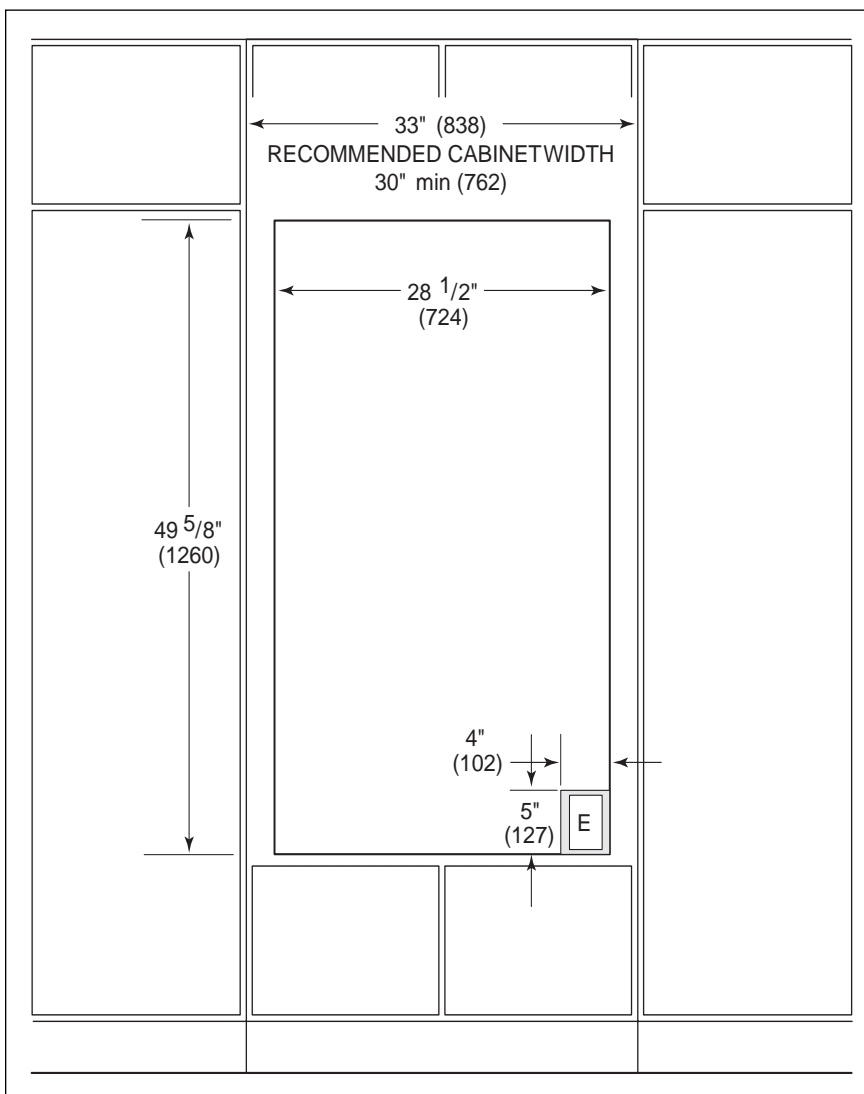

Figure 2-12. Front Cutout Dimensions and Electrical Placement

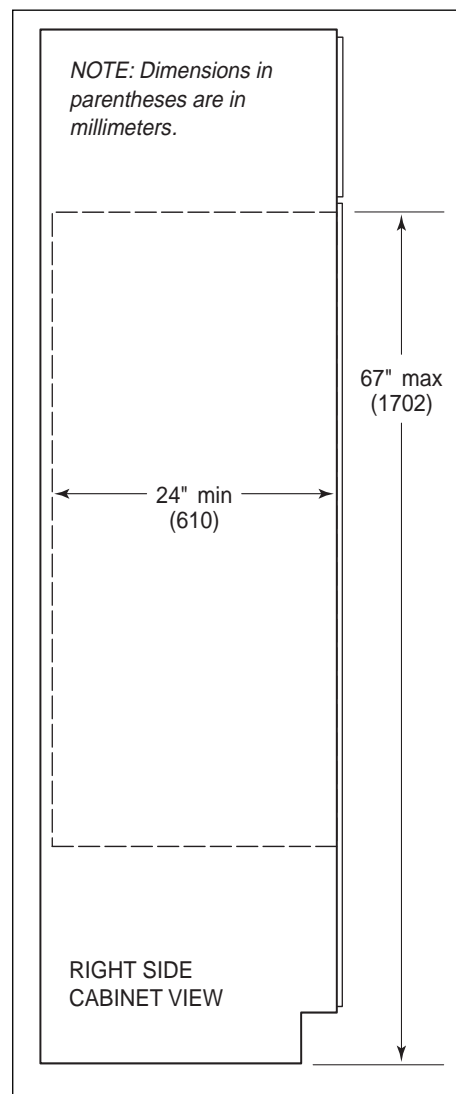

Figure 2-13. Side View

CABINET CUTOUT DIMENSIONS

Side-by-Side Wall Oven

NOTE: Dimensions in parentheses are in millimeters.

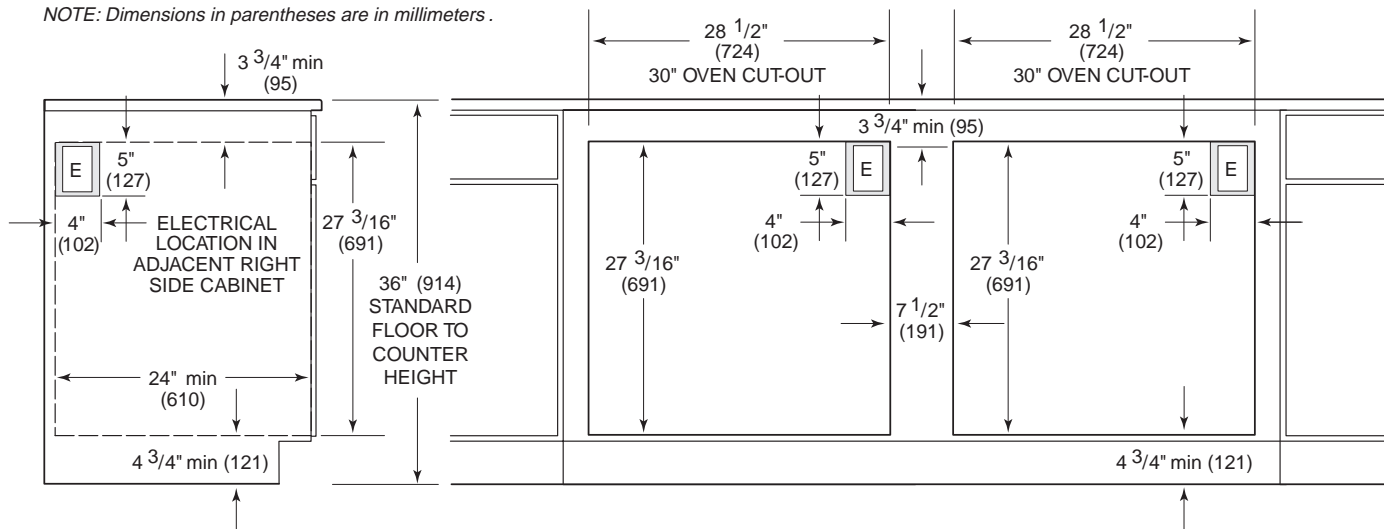

Figure 2-14. Undercounter Cutout Dimensions and Electrical Placement for SO30

NOTE: Dimensions in parentheses are in millimeters.

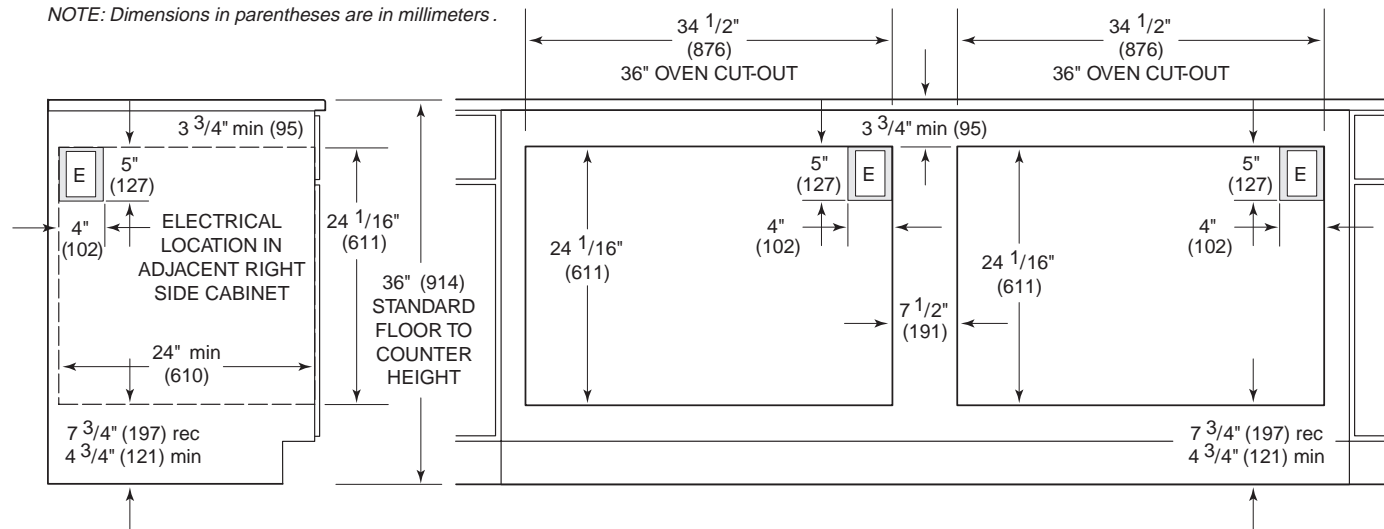

Figure 2-15. Undercounter Cutout Dimensions and Electrical Placement for SO36

SECTION 3

ELECTRONIC CONTROL SYSTEM

ELECTRONIC CONTROL TERMINOLOGY & COMPONENT DESCRIPTIONS

All Wolf wall ovens utilize an electronic control system. The electronic control system monitors, regulates and controls a variety of functions. The control system also displays error codes to identify possible problems with the unit. The table below defines some of the basic electronic control system terminology and describes some of the electronic system components. An understanding of the following information is needed in order to comprehend the input operations and functions of the electronic control system.

<u>Term / Component</u>	<u>Definition / Description</u>
Oven Controller.....	The printed circuit board containing the microprocessor and logic inputs which communicates with the oven display, keyboard, stepper motor control board.
Relay Board.....	The printed circuit board containing the microprocessor, relays and electrical connections which control and monitor functions and operations of the unit.
Oven Display.....	A vacuum fluorescent display which shows oven temperature, cooking modes, error codes, cook times and stop time.
Stepper Motor Control Board.....	The printed circuit board containing a transformer and logic control to drive the stepper motor.
Control Panel Assembly.....	The head assembly containing the oven display(s) and keyboard.
Relays.....	The electrical components on the relay board that switch other components in the unit ON and OFF when instructed to do so by the microprocessor.
Microprocessor.....	An electrical component on the control board which receives electrical signals from other components, processes that information, then sends an electrical signal to the relays on the board to open or close, and other components in the unit to switch on or off.
Keyboard.....	An assembly of glass and mylar which connects into the upper oven display.
Error Codes.....	Number or word description which appears on the oven display if the unit experiences specific problems related to electrical signals supplied by the electrical components.
MDL.....	Motor door latch assembly which incorporates the latch motor drive, unlatch switch, latch switch and door switch.
RTD.....	The oven(s) temperature sensing device.
DLB.....	A component on the relay board which is a relay that connects and disconnects the L2 line to the elements when energized by logic from the oven controller.

UNIQUE ELECTRONIC CONTROL INPUT OPERATIONS

The following few pages illustrate electronic control input operations that you would not expect a customer to perform everyday. The input operations described are: Field Option Mode, Sabbath Mode, Delayed Start Mode, Probe Mode and Self-Clean Mode.

Field Option Mode

Field option mode allows for the user to adjust specific options of the oven controller, such as User Preference Offset (*adjusting temperature ± 35°*), Temperature Display Preference (*choosing between °F, Fahrenheit or °C, Celsius*) and Clock Display Preference (12 Hour Clock or 24 Hour Clock).

NOTE: Field Option Mode must be entered with the oven(s) turned OFF.

To initiate Field Option Mode, Press and hold the TEMPERATURE key for five seconds.

NOTE: Pressing the CLEAR key will cancel the Field Option Mode.

User Preference Offset

This option allows the user to offset a specific oven temperature ±35° in 1°F (Fahrenheit) increments. Once in Field Option Mode, press the number keys to input the numeric value of the offset and press the TEMPERATURE key to toggle between ±. The new offset is accepted ten seconds after the last key stroke or by pressing the ENTER key. (See Figure 3-1). Pressing the CLEAR key will cancel the Field Option Mode.

NOTE: Entering a positive number will increase oven temperature.

NOTE: User Preference Offset will only work for °F (Fahrenheit).

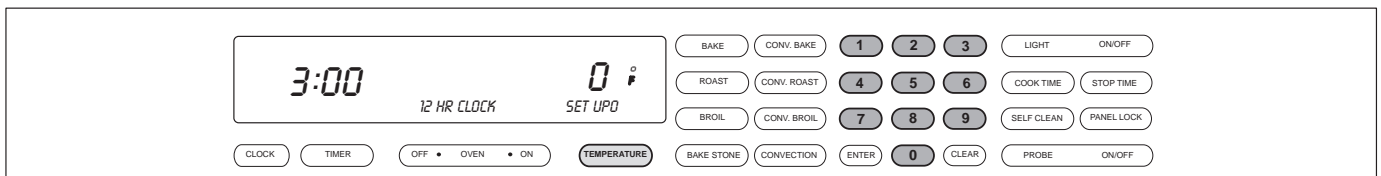

Figure 3-1. User Preference Offset. Press and HOLD the TEMPERATURE key for five seconds. Then, press the number keys to enter a new numeric value up to 35. Now, press the TEMPERATURE key to toggle between ±.

Temperature Display Preference

This option allows the user to choose how the temperature is displayed, °F (Fahrenheit) or °C (Celsius), and/or back again. Once in Field Option Mode, press the COOK TIME key to toggle between °C and °F. The new display, °C or °F is accepted ten seconds after the last key stroke or by pressing the ENTER key. See Figure 3-2. Pressing the CLEAR key will cancel the Field Option Mode.

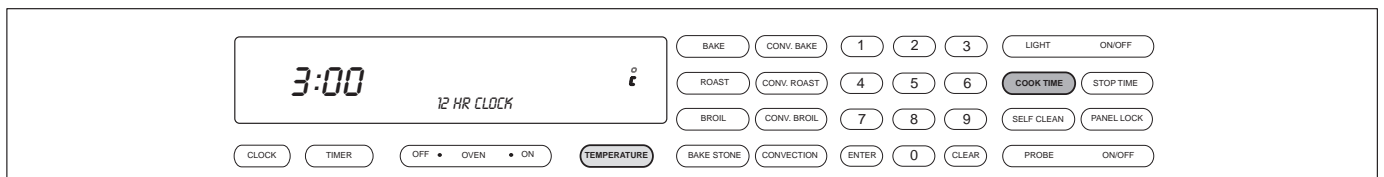

Figure 3-2. Temperature Display Preference. Must be in Field Option Mode. Now, press the COOK TIME key to toggle between °C and °F.

Clock Display Preference

This option allows the user to choose how the clock is displayed, 12 hour or 24 hour, and/or back again. Once in Field Option Mode, press the CLOCK key to toggle between 12 hour or 24 hour clock. The new display is accepted ten seconds after the last key stroke or by pressing the ENTER key. See Figure 3-2.1. Pressing the CLEAR key will cancel the Field Option Mode.

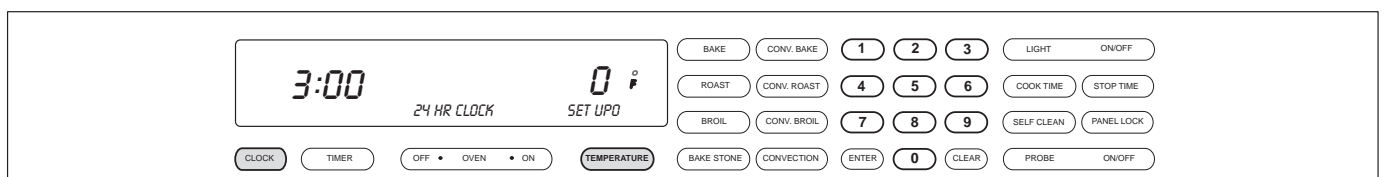

Figure 3-2.1. Clock Display Preference. Must be in Field Option Mode. Now, press the CLOCK key to toggle between 12 hour and 24 hour clock.

Sabbath Feature

Sabbath Feature was incorporated into the electronic control system for the observance of certain religious holidays. Once Sabbath Mode has been entered, all of the oven functions have been disabled except the OFF key.

To initiate Sabbath feature, the oven must be OFF. Press UPPER or LOWER OVEN ON key for a double oven or OVEN ON key for a single oven. (See Figure 3-3). Turn on the interior oven lights by pressing the OVEN LIGHT ON key (Optional). Press the BAKE or ROAST key. A preset temperature of 350° will be shown in the display. To change temperature, immediately enter another temperature using the number keys, then press ENTER. (See Figure 3-4). Now, press and hold the ENTER key for five seconds. The oven will chime twice and the word SABBATH appears in the display window. (See Figure 3-5). Repeat these steps above for each oven(s).

To exit the Sabbath Mode, press the UPPER or LOWER OVEN OFF key or the OVEN OFF key, depending on the model. (See Figure 3-6).

NOTE: The oven(s) will remain on until the Sabbath Mode is cancelled.

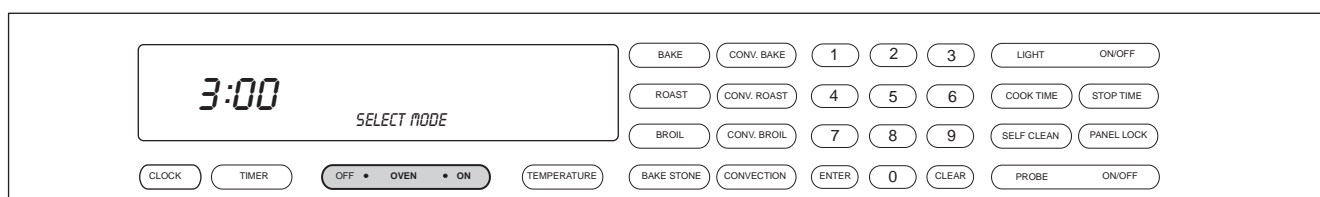

Figure 3-3. To initiate Sabbath Mode, the oven must be OFF. Press Oven ON key. For Double Ovens select either Upper Oven ON key or Lower Oven ON key.

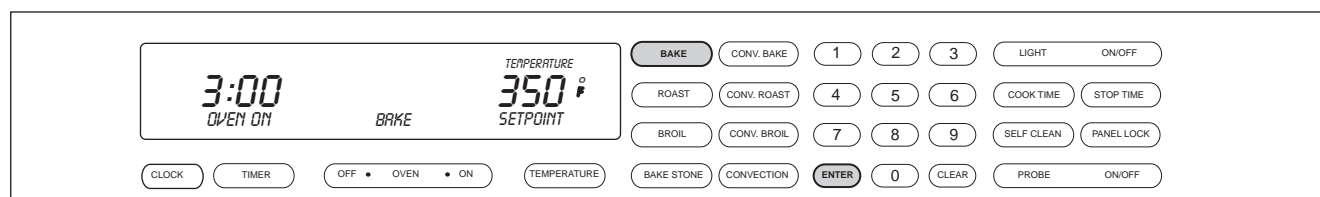

Figure 3-4. Press the BAKE key. A preset temperature of 350°F will be shown in the display. To change temperature, immediately enter another temperature using the number keys. Then, press ENTER.

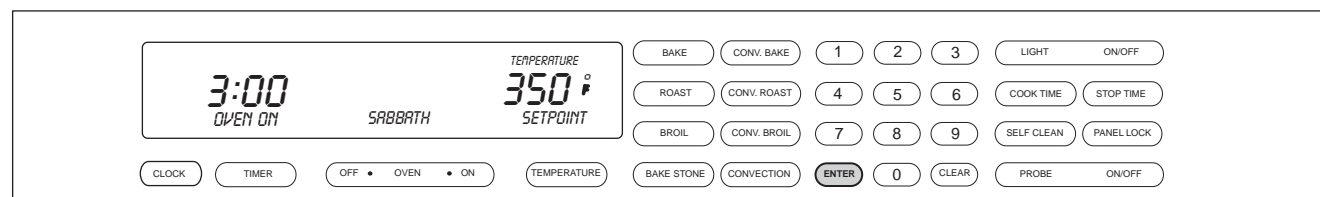

Figure 3-5. Now, press and HOLD THE ENTER key for 5 seconds. The oven will chime twice and the word Sabbath appears in the display.

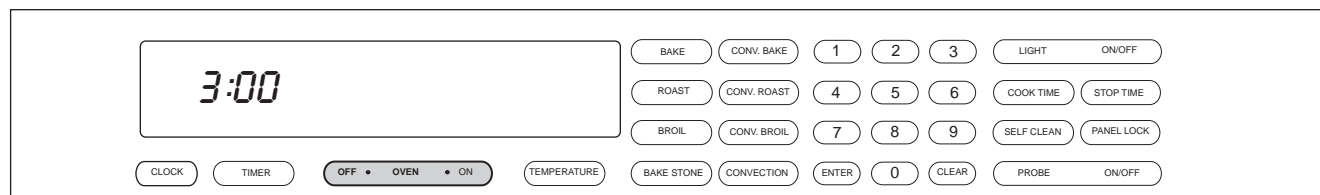

Figure 3-6. To exit Sabbath Mode. Press the Oven OFF key. For Double Ovens select either Upper Oven OFF key or Lower Oven OFF key.

Time Cook Feature

Time Cook Feature controls the automatic timing of the oven(s) ON and OFF function by setting the cooking time to start immediately and turn off when the desired cooking is complete. To accomplish time cook, the time of day clock is used and therefore the correct time must be displayed prior to programming.

To initiate Time Cook, the oven must be OFF. First press the Oven ON key. (See Figure 3-7). For Double Ovens press the Upper Oven ON key or the Lower Oven ON key. Now, press a desired cooking mode (example Bake Mode). A preset temperature of 350°F is shown in the display. To change the temperature from 350°F, immediately enter another temperature using the number keys. (See Figure 3-8). Then, press the COOK TIME key. Then, enter the hours/minutes desired for cooking. The oven(s) will start heating after a five second delay or by pressing the ENTER key. (See Figure 3-9). To exit TIME COOK feature, press the Oven OFF key. (See Figure 3-10). For the Double Oven, press the Upper Oven OFF key or the Lower Oven Off key.

NOTE: The oven should always be preheated in this mode. The oven will chime after the oven reaches preheat temperature.

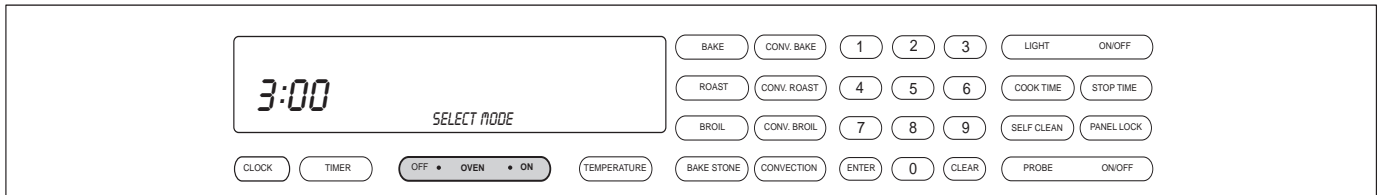

Figure 3-7. To initiate Time Cook Feature, the oven must be OFF. Press Oven ON key. For Double Ovens select either Upper Oven ON key or Lower Oven ON key.

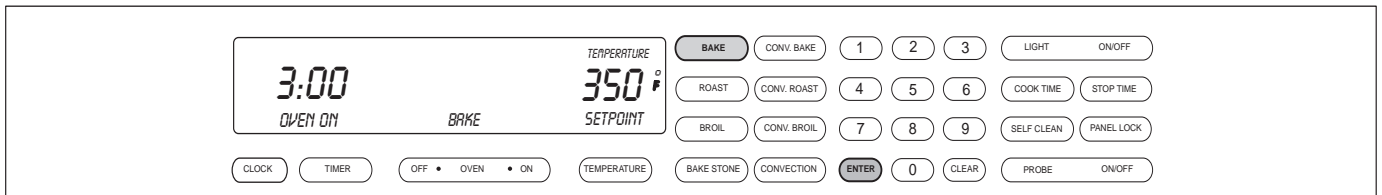

Figure 3-8. Press a desired Cooking Mode. (Example: Bake Mode). A preset temperature of 350°F will be shown in the display. To change temperature, immediately enter another temperature using the number keys.

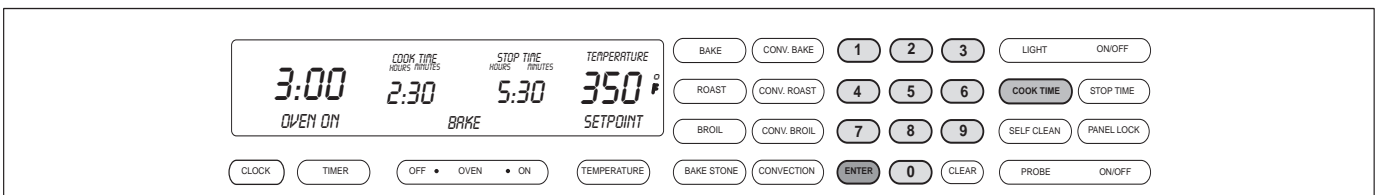

Figure 3-9. Now, press the Cook Time key. Now, enter the hours/minutes desired for cooking. The Stop Time will automatically be entered in the display. Then, press the ENTER key. The oven(s) will now start heating and then turn off when the cooking times has completed.

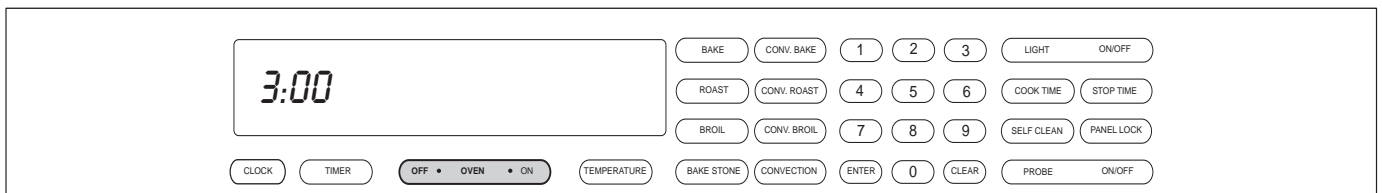

Figure 3-10. To exit the Cook Time Feature. Press the Oven OFF key. For Double Ovens select either Upper Oven OFF key or Lower Oven OFF key.

Delayed Start Feature

This feature controls the automatic timing of the oven(s) ON and OFF function by setting the cooking mode to start later in the day and turn off when the cooking is complete. It can also be set to turn off at a preset time. To accomplish delayed start and/or stop, the time of day clock is used and therefore the correct time must be displayed prior to programming.

NOTE: This mode will work for all cooking modes except Broil, Convection Broil and Bake Stone Mode.

To initiate Delayed Start Mode, the oven must be OFF. Press the Upper or Lower Oven ON key or the Oven ON key, depending on the model. (See Figure 3-11). Press the desired cooking mode key. (See Figure 3-12). To change preset temperature, immediately enter another temperature using the number keys. Next, press Stop Time. Then, using the number keys, enter the time for which the oven needs to turn off. *Example: Set 6:00 for the time of day the oven turns off.* (See Figure 3-13). Then, enter the Cook Time using the number keys to set the hours/minutes the oven will stay on. *Example: Set 3:30 for the oven to remain on for 3-1/2 hours.* Now, press the ENTER key. (See Figure 3-14). The display appears as if the oven is on. To exit Delayed Start Mode, press Upper or Lower Oven OFF or Oven OFF key. (See Figure 3-15).

NOTE: With the example used above, heating will not start for 3-1/2 hours prior to 6 o'clock which will be 2:30 on the time of day clock.

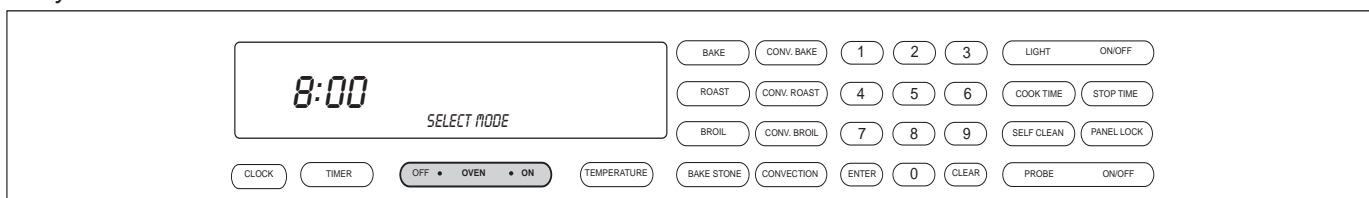

**Figure 3-11. To initiate Delayed Start Mode, Press Oven ON key.
For Double Ovens select either Upper Oven ON key or Lower Oven ON key.**

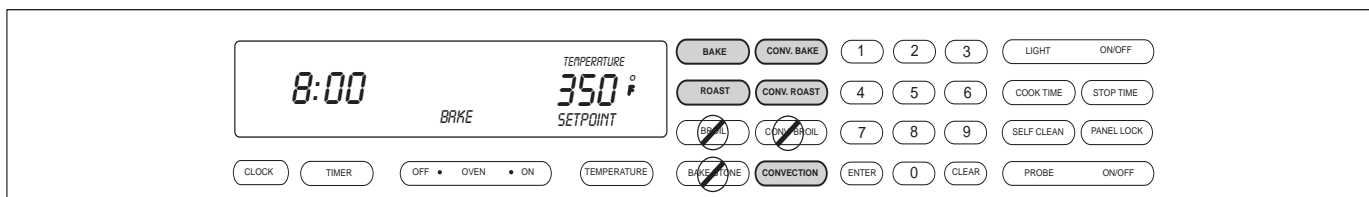

**Figure 3-12. Press desired Cooking Mode. Bake, Roast, Convection Bake, Convection Roast or Convection.
NOTE: Broil, Convection Broil and Bake Stone will not work in this mode.**

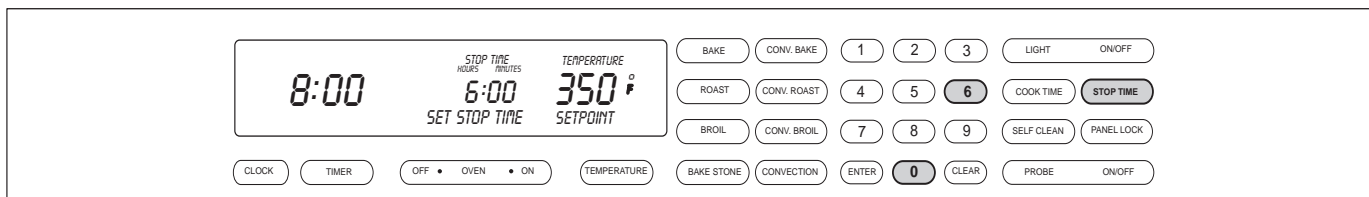
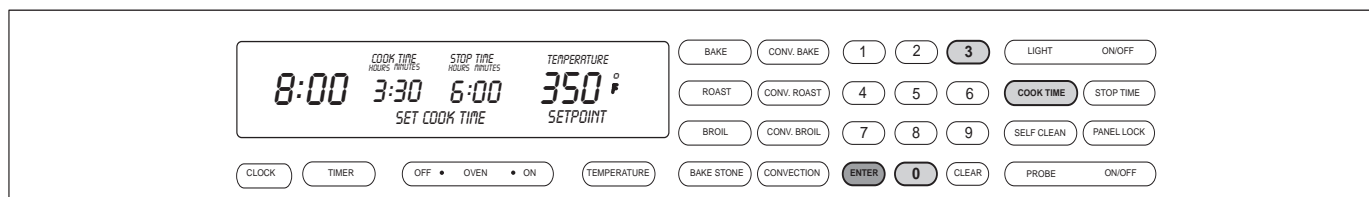

Figure 3-13. Press Stop Time. Then, using number keys, enter time of day to turn oven off. Example 6:00



**Figure 3-14. Press Cook Time. Then, using number keys, enter hours/minutes the oven will stay on.
Example 3:30. Now, press ENTER.**

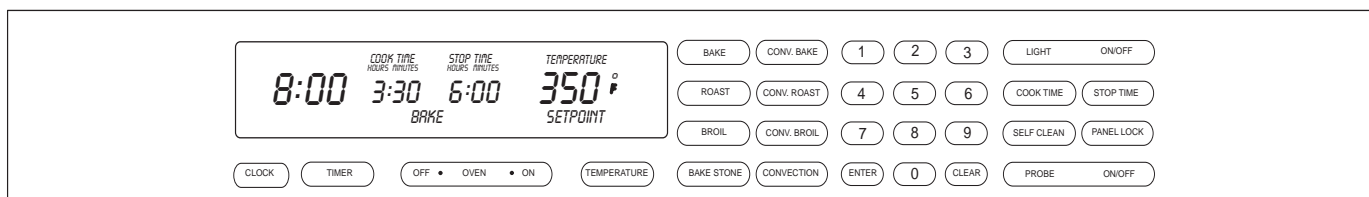

Figure 3-15. Display appears as if oven is on.

Temperature Probe Feature

The Temperature Probe Feature is used to measure internal temperatures of the food being cooked. It is an accurate way to achieve the perfect doneness regardless of the type, cut or weight of food. When using the Temperature Probe Mode, program the recommended internal carving temperature, as found in the Use and Care Information Guide. (See Figure 3-16). The temperature should be reduced by five degrees when setting the Temperature Probe Mode.

USDA Internal Temperature Recommendations	
Beef, Lamb, Pork and Veal	Poultry
145°F Medium Rare	170°F Breast
160°F Medium	180°F Thigh
170°F Well Done	165°F Stuffing

Figure 3-16. USDA Internal Temperature Recommendations

To initiate Temperature Probe Mode, first preheat the oven. Now, the probe should be inserted into the thickest part of the product being cooked. Plug the probe connector into the oven receptacle (located on the top right side of the oven cavity), all the way until it snaps into place. Next, press the PROBE key. (See Figure 3-17). Now, using the number keys enter the recommended internal cooking temperature minus five degrees. (See Figure 3-18). Then, press ENTER. The word “Lo” appears in the display as the probe temperature, until the probe registers 100°F. (See Figure 3-19). Once the probe has registered 100°F, the display will start showing the degrees rising up to the programmed setting for the probe temperature. Once the probe temperature has been reached the oven will chime three times signaling the item being cooked is done. Now, unplug the probe connector from the oven receptacle. To exit the Temperature Probe Mode, press the Oven OFF key. For the double oven, press the Upper Oven OFF key or Lower Oven OFF key.

NOTE: The oven will continue to chime every thirty seconds until the probe has been removed from the oven receptacle.

NOTE: Oven temperature remains on even when temperature probe is unplugged.

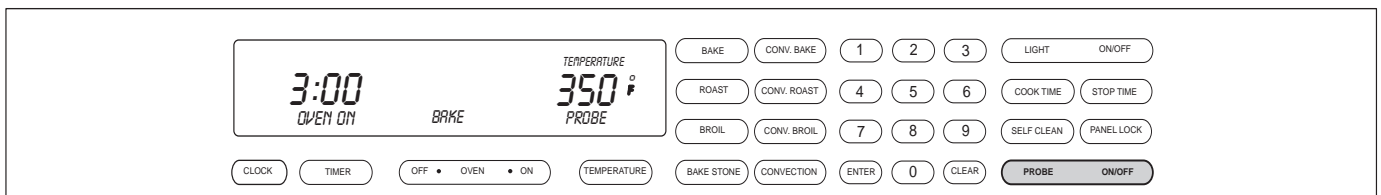

Figure 3-17. To initiate Temperature Probe Mode, press PROBE key.

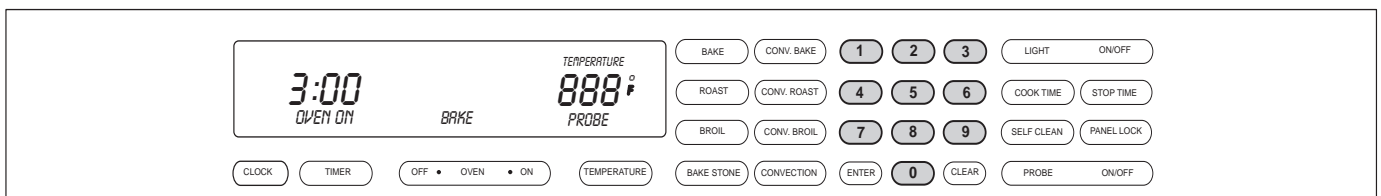

Figure 3-18. Using number keys, enter internal cooking temperature minus five degrees.

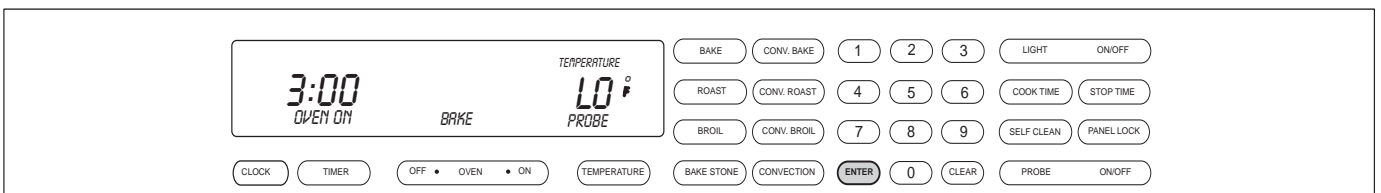

Figure 3-19. Press ENTER, the word Lo appears in the oven display.

Self-Clean Mode

In Self-Clean Mode, the oven is heated in graduated stages to a preset high temperature. The cycling of the bake and broil elements in Stage One last for the first twelve minutes. In Stage Two, the bake element cycles for 0 - 12 seconds and the broil element cycles for 12 - 60 seconds. The cycling of the elements in Stage Two continues until the high preset temperature of 850°F is obtained. During this process, food soil is burned off leaving some white ash residue.

Once the Self-Clean Mode has been initiated the oven door locks, unless the Self-Clean Mode is used with the Delayed Start Mode. The oven door will remain locked until the oven temperature drops below 300°F.

NOTE: If the Self-Clean Mode is stopped once it has been started, the door will remain locked until the temperature inside has cooled below 300°F.

NOTE: The average time for the Self-Clean Mode is three hours plus one hour to cool down.

NOTE: For model DO30 only one cavity can be self-clean at a time.

NOTE: For Model DO30, when self-cleaning one cavity the other cavity is non-functional until self-clean is finished.

To initiate Self-Clean Mode, first the oven must be OFF. Press the Oven ON key. (See Figure 3-20). For Double Ovens, press the Upper Oven ON key or Lower Oven ON key. Next, press the SELF-CLEAN key. Follow instructions in display, if applicable, then press the ENTER key. (See Figure 3-21). Press ENTER key again to activate SELF-CLEAN. To exit the Self-Clean Mode, press the Oven OFF key. (See Figure 3-22). For Double Oven press the Upper Oven OFF key or the Lower Oven OFF key.

NOTE: To use Self-Clean Mode with Delayed Start Mode, follow the instruction for Delayed Start Mode.

To change the Self-Clean time for 3 to 4 hours. Press the Oven ON key. Next, press the SELF-CLEAN key. Then, press the COOKTIME key. Now, using the number keys enter the desired self-cleaning time. (Example: 3 hours 15 minutes). As long as the self-clean time is between 3 to 4 hours, the time can be entered. Then, press ENTER.

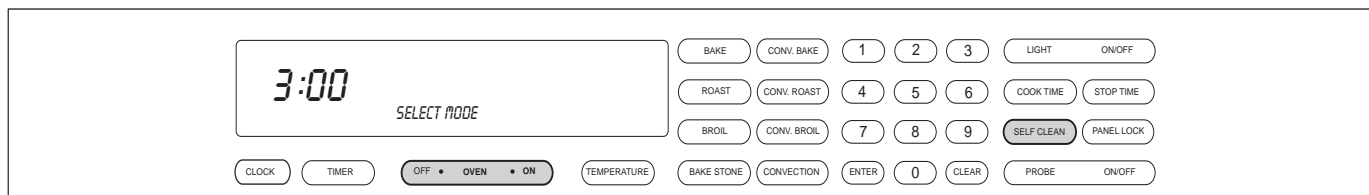

Figure 3-20. To initiate Self-Clean Mode, Press the Oven ON key.
For Double Oven, press the Upper Oven ON key or the Lower Oven ON key.

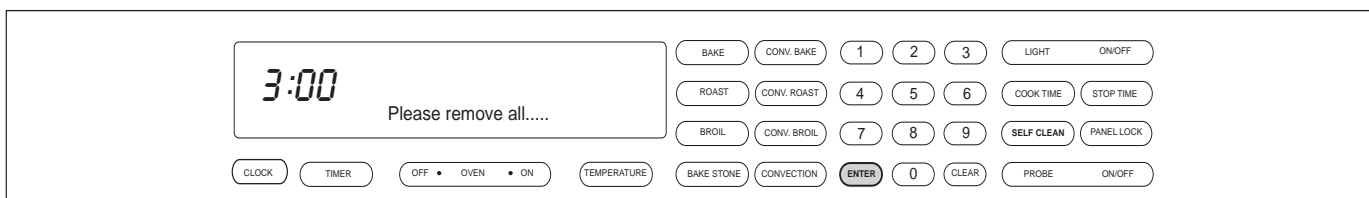

Figure 3-21. Press the SELF-CLEAN key. Scrolling display will instruct to remove racks, press the “ENTER” key to initiate SELF-CLEAN. Starting with serial #16000000 rack guides must also be removed.

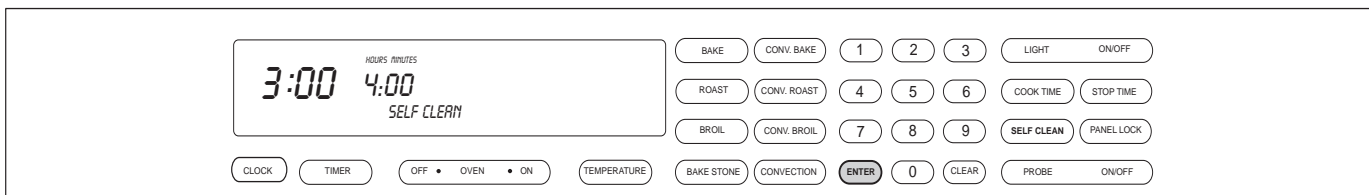

Figure 3-22. Press ENTER again to activate SELF-CLEAN.
To exit the Self-Clean Mode, press the Oven OFF key.
For Double oven, press the Upper Oven OFF key or the Lower Oven OFF key.

ELECTRONIC CONTROL INPUT OPERATIONS

The following few pages illustrate electronic control input operations that you might expect a customer to perform everyday. The input operations described are: Bake, Convection, Convection Bake, Broil, Convection Broil, Roast, Convection Roast and Bake Stone Mode.

Bake Mode

In Bake Mode both the hidden bake element and the broil element are used to heat the air and cycle to maintain temperature. The hidden bake element operates approximately 80 percent of the time and the broil element operates approximately 10 percent of the time. The oven(s) should always be preheated when using Bake Mode.

To initiate Bake Mode, the oven must be OFF. First press the Oven ON key. (See Figure 3-23). For Double Ovens press the Upper Oven ON key or the Lower Oven ON key. Now, press the BAKE key. A preset temperature of 350°F is shown in the display. The oven begins to heat after 5 seconds or by pressing the ENTER key. (See Figure 3-24). To change the temperature from 350°F, immediately enter another temperature using the number keys. Then, press the ENTER key. (See Figure 3-25). To exit the Bake Mode, press the Oven OFF key. (See Figure 3-26). For the Double Oven, press the Upper Oven OFF key or the Lower Oven Off key.

NOTE: The oven should always be preheated in this mode. The oven will chime after the oven reaches preheat temperature.

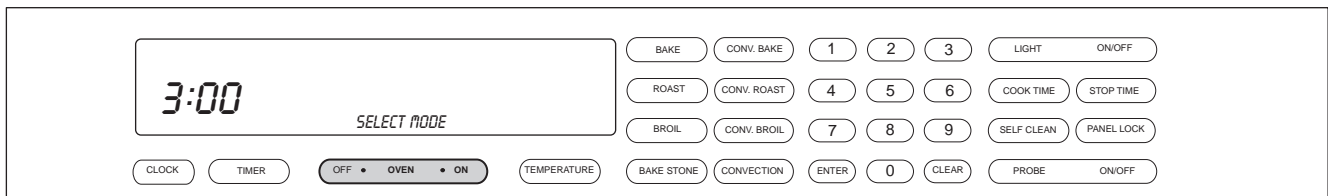

**Figure 3-23. To initiate Bake Mode, Press the Oven ON key.
For Double Oven, press the Upper Oven ON key or the Lower Oven ON key.**

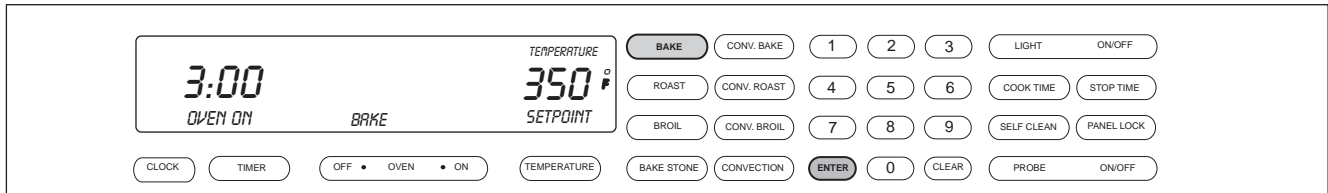

**Figure 3-24. Press the BAKE key. A preset temperature of 350°F will be shown in the display.
The oven begins to heat after 5 seconds or by pressing the ENTER key.**



**Figure 3-25. To change the preset temperature, immediately press the number keys to enter a new temperature.
Then, press the ENTER key.**

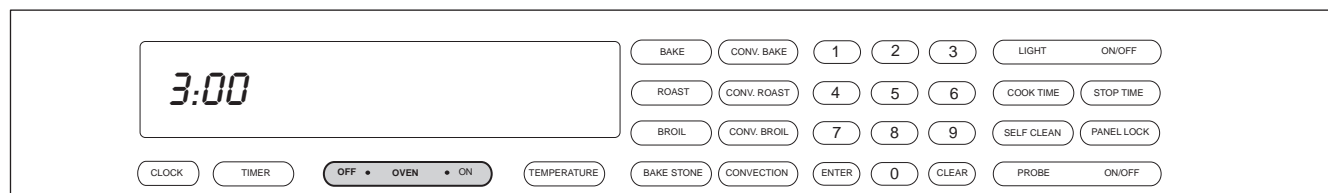

**Figure 3-26. To exit the Bake Mode, press the Oven OFF key.
For Double oven, press the Upper Oven OFF key or the Lower Oven OFF key.**

Convection Mode

The Convection Mode uses dual convection fans, each with heating elements mounted on the back wall of the oven cavity. The convection fans move air sequential, throughout the entire oven cavity creating uniform air movement. This air movement makes it possible to cook on all six levels of the cooking racks simultaneously. The heating elements and convection fans are cycled sequentially (on and off), resulting in even browning.

NOTE: In Convection Mode, standard recipe temperature should be reduced by 25°F.

NOTE: The oven should always be preheated in this mode. The oven will chime after the oven reaches preheat temperature.

To initiate Convection Mode, the oven must be OFF. First, press the Oven ON key. (See Figure 3-27). For the Double Ovens, press the Upper Oven ON key or the Lower Oven ON key. Now, press the CONVECTION key. A preset temperature of 325°F will appear in the display. The oven begins to heat after 5 seconds or by pressing the ENTER key. (See Figure 3-28). To change the temperature from the preset 325°F, immediately enter another temperature using the number keys. Then, press the ENTER key. (See Figure 3-29). To exit the Convection Mode, press the Oven OFF key. (See Figure 3-30). For Double Ovens press the Upper Oven OFF key or the Lower Oven OFF key.

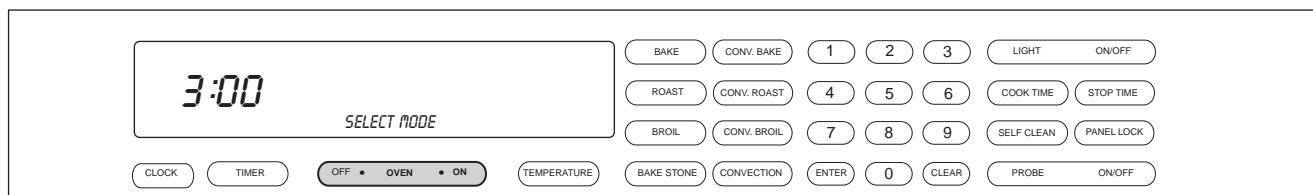

**Figure 3-27. To initiate Convection Mode, Press the Oven ON key.
For Double Oven, press the Upper Oven ON key or the Lower Oven ON key.**

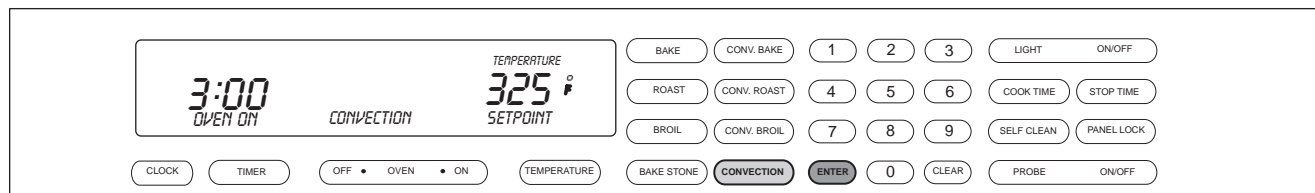

**Figure 3-28. Press the CONVECTION key. A preset temperature of 325°F will be shown in the display.
The oven begins to heat after 5 seconds or by pressing the ENTER key.**

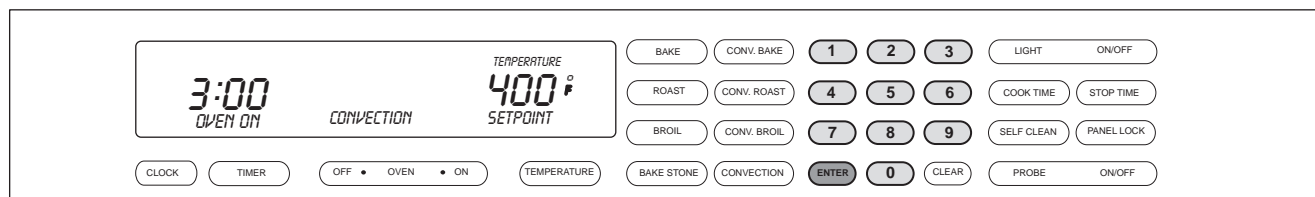

**Figure 3-29. To change the preset temperature, immediately press the number keys to enter a new temperature.
Then, press the ENTER key.**

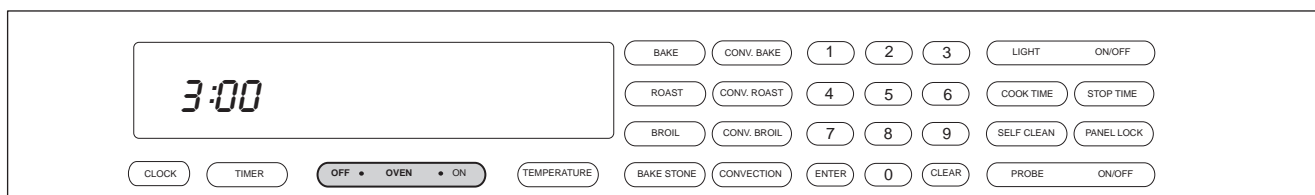

**Figure 3-30. To exit the Convection Mode, press the Oven OFF key.
For Double oven, press the Upper Oven OFF key or the Lower Oven OFF key.**

Convection Bake Mode

Convection Bake Mode combines heat from two convection heating elements with some heat from the hidden bake element. The two convection fans and convection elements operate sequentially (on and off), to circulate the heat within the oven cavity. The added heat from the hidden bake element make this an ideal cooking mode for pie baking. In this mode the convection elements are on 45 percent of the time and the hidden bake element is on 90 percent of the time.

NOTE: In Convection Bake Mode, standard recipe temperature should be reduced by 25°F.

NOTE: The oven should always be preheated in this mode. The oven will chime after the oven reaches preheat temperature.

To initiate Convection Bake Mode, the oven must be OFF. First, press the Oven ON key. (See Figure 3-31). For the Double Ovens, press the Upper Oven ON key or the Lower Oven ON key. Now, press the CONVECTION BAKE key. A preset temperature of 375°F will appear in the display. The oven begins to heat after 5 seconds or by pressing the ENTER key. (See Figure 3-32). To change the temperature from the preset 375°F, immediately enter another temperature using the number keys. Then, press the ENTER key. (See Figure 3-33). To exit the Convection Mode, press the Oven OFF key. (See Figure 3-34). For Double Ovens press the Upper Oven OFF key or the Lower Oven OFF key.

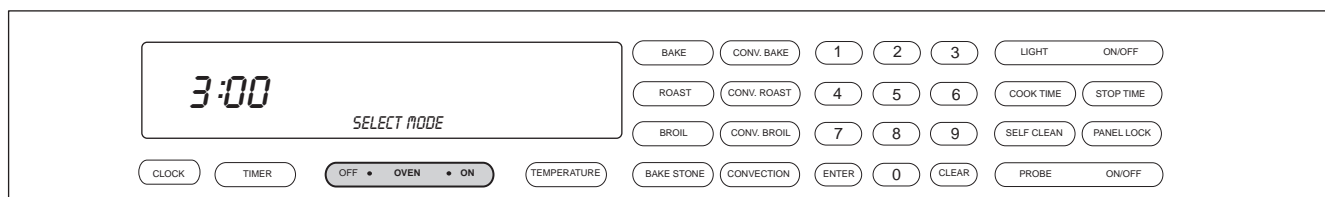

Figure 3-31. To initiate Convection Bake Mode, Press the Oven ON key. For Double Oven, press the Upper Oven ON key or the Lower Oven ON key.

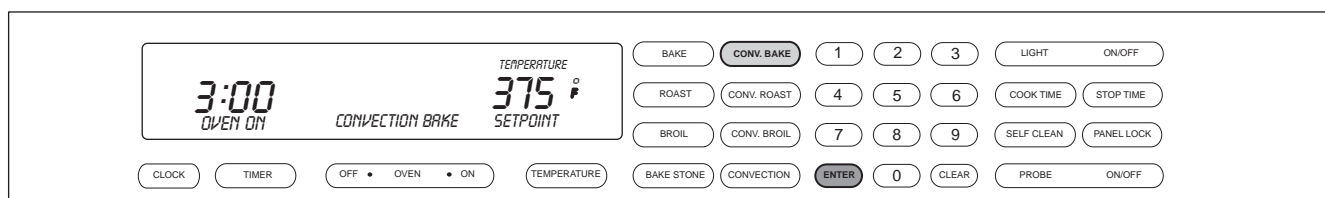

Figure 3-32. Press the CONVECTION BAKE key. A preset temperature of 375°F will be shown in the display. The oven begins to heat after 5 seconds or by pressing the ENTER key.

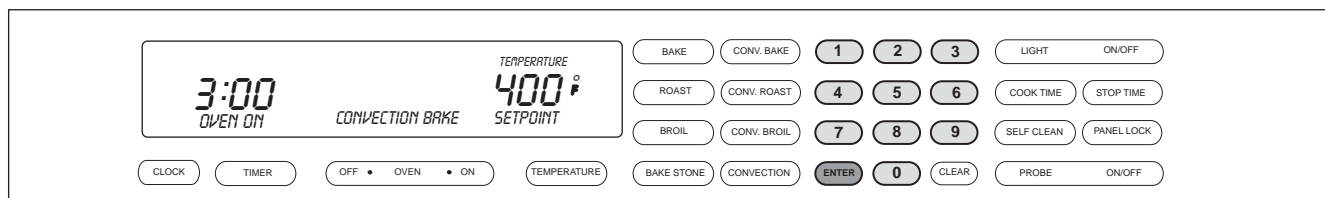

Figure 3-33. To change the preset temperature, immediately press the number keys to enter a new temperature. Then, press the ENTER key.

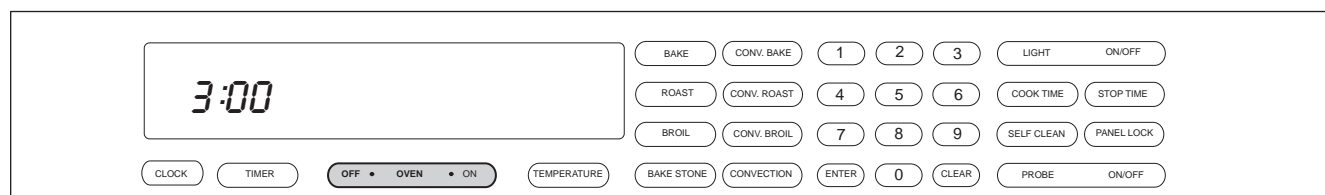

Figure 3-34. To exit the Convection Bake Mode, press the Oven OFF key. For Double oven, press the Upper Oven OFF key or the Lower Oven OFF key.

Broil Mode

In Broil Mode the top broil element is used to conduct an intense radiant heat which browns one side of the food being cooked. Food cooked in any of the Broil Modes must be turned to finish cooking and browning the other side. There are three Broil Level temperatures that can be used in this mode, Hi Broil, Medium Broil and Lo Broil.

NOTE: Preheat is never used in Broil Mode.

NOTE: The oven door **MUST** be closed during this mode.

To initiate Broil Mode, the oven must be OFF. First, press the Oven ON key. (See Figure 3-35). For the Double Ovens, press the Upper Oven ON key or the Lower Oven ON key. Now, press the BROIL key. A preset temperature of 550° and the number “1” and the word HI will appear in the display. The broiler begins to heat after 5 seconds or by pressing the ENTER key. (See Figure 3-36). To change the preset temperature, immediately press the “2” key for Medium Broil at 450° or press the “3” key for Lo Broil at 350°F. Then, press the ENTER key. (See Figure 3-37). To exit the Broil Mode, press the Oven OFF key. (See Figure 3-38). For Double Ovens press the Upper Oven OFF key or the Lower Oven OFF key.

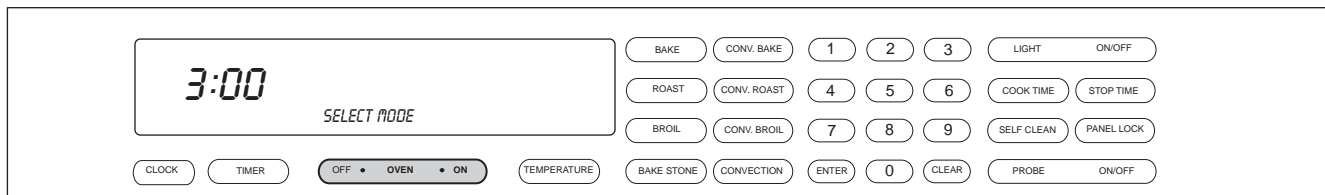

**Figure 3-35. To initiate Broil Mode, Press the Oven ON key.
For Double Oven, press the Upper Oven ON key or the Lower Oven ON key.**

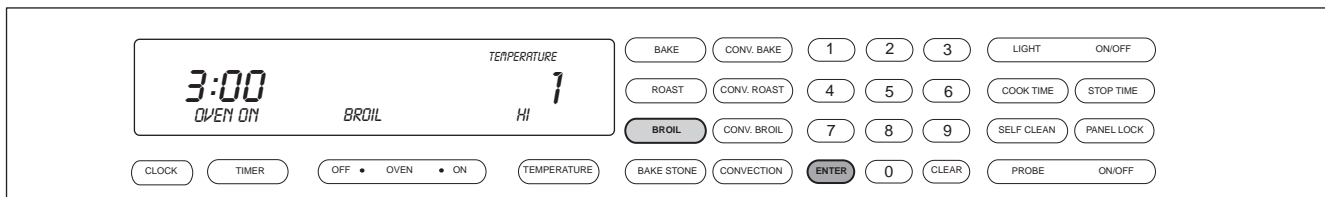

Figure 3-36. Press the BROIL key. A preset temperature of 550°F is selected and the number “1” and HI will be shown in the display. The oven begins to heat after 5 seconds or by pressing the ENTER key.

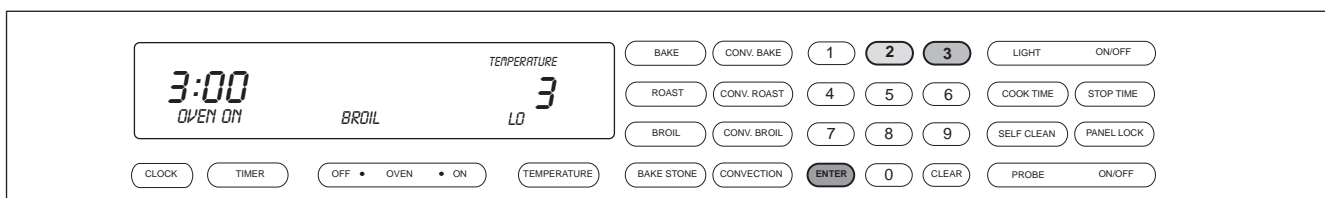
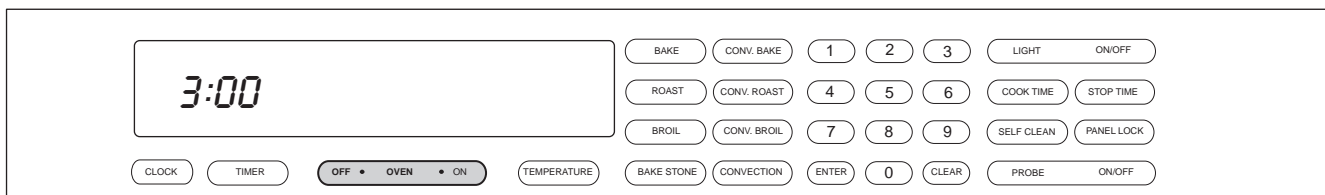

Figure 3-37. To change the preset temperature, immediately press the “2” key for Medium Broil at 450°F. Press the “3” key for Low Broil at 350°F Then, press the ENTER key.



**Figure 3-38. To exit the Broil Mode, press the Oven OFF key.
For Double oven, press the Upper Oven OFF key or the Lower Oven OFF key.**

Convection Broil Mode

Convection Broil Mode uses intense radiant heat from the top broil element. The convection fans also operate continuously to maintain air movement. Convection Broil Mode shortens broiling times for thicker cuts of meat. The intense radiant heat browns and sears the surface of the meat, while the convection fans keep the interior of the meat moist.

NOTE: Preheat is never used in Convection Broil Mode.

NOTE: The oven door **MUST** be closed during this mode.

To initiate Convection Broil Mode, the oven must be OFF. First, press the Oven ON key. (See Figure 3-39). For the Double Ovens, press the Upper Oven ON key or the Lower Oven ON key. Now, press the CONVECTION BROIL key. A preset temperature of 550° and the number “1” and the word HI will appear in the display. The broiler begins to heat after 5 seconds or by pressing the ENTER key. (See Figure 3-40). To change the preset temperature, immediately press the “2” key for Medium Broil at 450° or press the “3” key for Lo Broil at 350°F. Then, press the ENTER key. (See Figure 3-41). To exit the Convection Broil Mode, press the Oven OFF key. (See Figure 3-42). For Double Ovens press the Upper Oven OFF key or the Lower Oven OFF key.

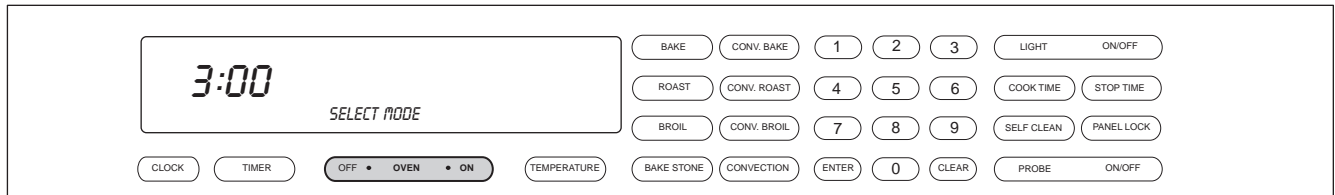

Figure 3-39. To initiate Convection Broil Mode, Press the Oven ON key. For Double Oven, press the Upper Oven ON key or the Lower Oven ON key.

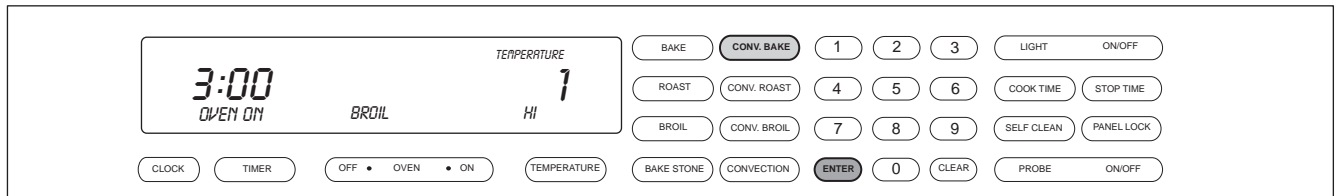

Figure 3-40. Press the CONVECTION BROIL key. A preset temperature of 550°F is selected and the number “1” and HI will be shown in the display. The oven begins to heat after 5 seconds or by pressing the ENTER key.

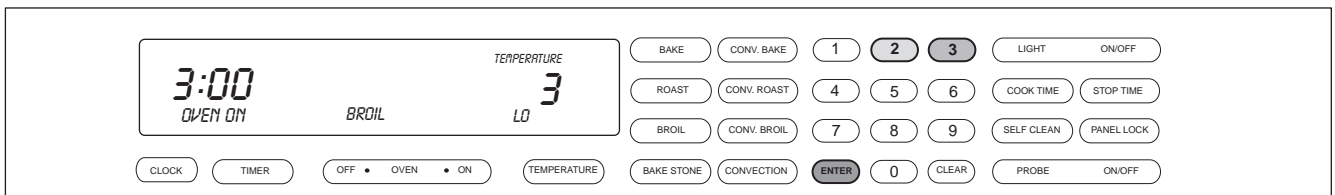

Figure 3-41. To change the preset temperature, immediately press the “2” key for Medium Broil at 450°F. Press the “3” key for Low Broil at 350°F. Then, press the ENTER key.

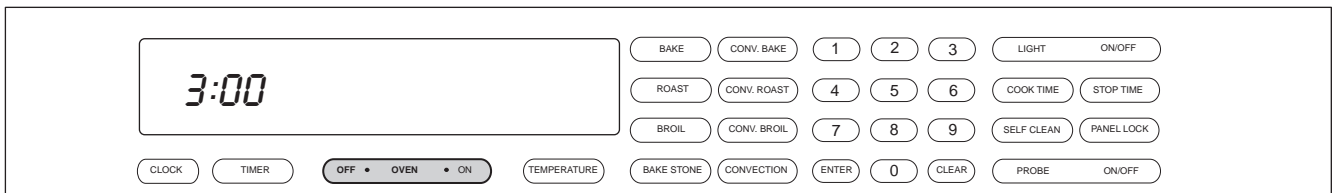

Figure 3-42. To exit the Convection Bake Mode, press the Oven OFF key. For Double oven, press the Upper Oven OFF key or the Lower Oven OFF key.

Roast Mode

In Roast Mode both the hidden bake element and the broil element are cycled to maintain the desired temperature. The hidden bake element operates 75 percent of the time and the broil element operates 25 percent of the time. This mode is especially designed for roasting tender cuts of meat that need to be covered.

NOTE: The oven should always be preheated in this mode. The oven will chime after the oven reaches preheat temperature.

To initiate Roast Mode, the oven must be OFF. First press the Oven ON key. (See Figure 3-43). For Double Ovens press the Upper Oven ON key or the Lower Oven ON key. Now, press the ROAST key. A preset temperature of 350°F is shown in the display. The oven begins to heat after 5 seconds or by pressing the ENTER key. (See Figure 3-44). To change the temperature from 350°F, immediately enter another temperature using the number keys. Then, press the ENTER key. (See Figure 3-45). To exit the Roast Mode, press the Oven OFF key. (See Figure 3-46). For the Double Oven, press the Upper Oven OFF key or the Lower Oven Off key.

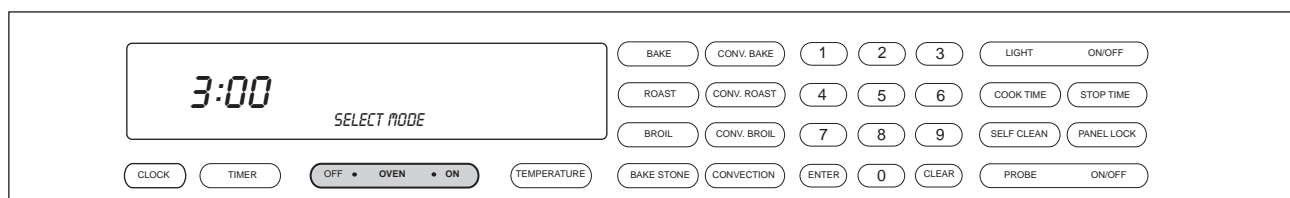

**Figure 3-43. To initiate Roast Mode, Press the Oven ON key.
For Double Oven, press the Upper Oven ON key or the Lower Oven ON key.**

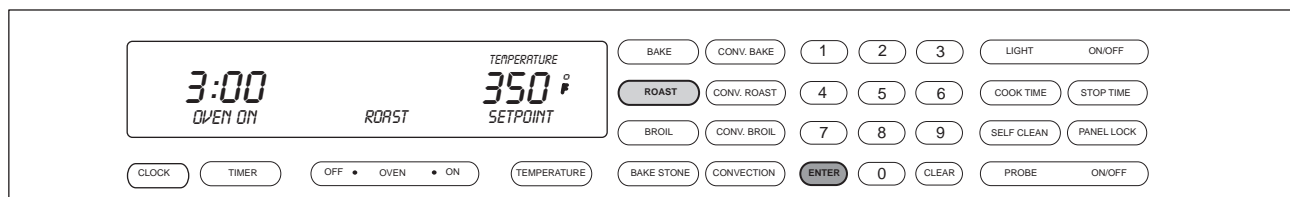

**Figure 3-44. Press the ROAST key. A preset temperature of 350°F will be shown in the display.
The oven begins to heat after 5 seconds or by pressing the ENTER key.**

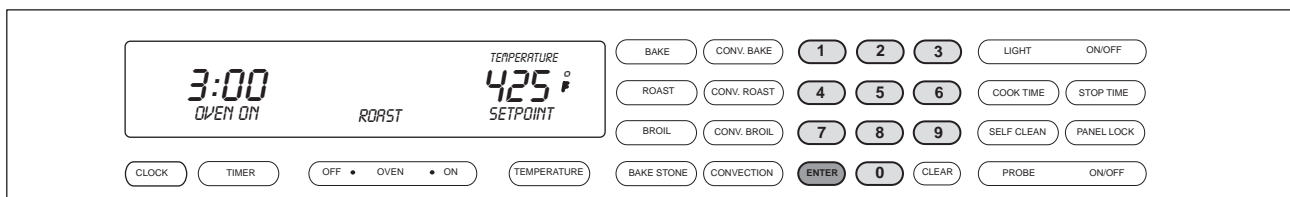

**Figure 3-45. To change the preset temperature, immediately press the number keys to enter a new temperature.
Then, press the ENTER key.**

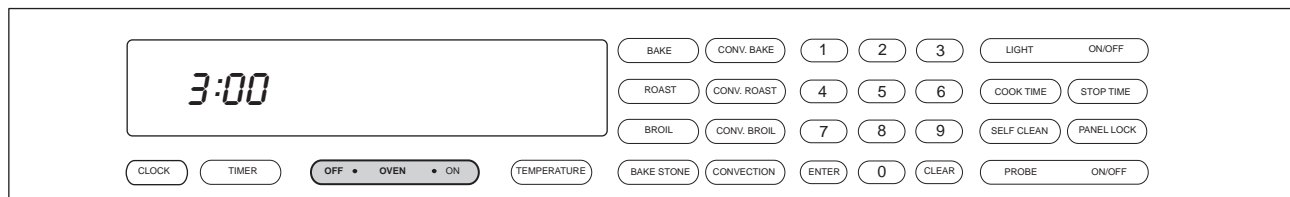

**Figure 3-46. To exit the Roast Mode, press the Oven OFF key.
For Double oven, press the Upper Oven OFF key or the Lower Oven OFF key.**

Convection Roast Mode

In Convection Roast Mode the dual convection fans with each convection element operate sequentially (on and off), along with the cycling of the top broil element. The convection elements are on 46 percent of the time and the broil element is on 16 percent of the time. The convection fans are on 100 percent of the time. This mode intensifies the convective and radiant heating. This combination gently browns the exterior and seals in juices making it perfect for roasting tender cuts of meat.

NOTE: The oven should always be preheated in this mode. The oven will chime after the oven reaches preheat temperature.

To initiate Convection Roast Mode, the oven must be OFF. First press the Oven ON key. (See Figure 3-47). For Double Ovens press the Upper Oven ON key or the Lower Oven ON key. Now, press the CONVECTION ROAST key. A preset temperature of 325°F is shown in the display. The oven begins to heat after 5 seconds or by pressing the ENTER key. (See Figure 3-48). To change the temperature from 325°F, immediately enter another temperature using the number keys. Then, press the ENTER key. (See Figure 3-49). To exit the Convection Roast Mode, press the Oven OFF key. (See Figure 3-50). For the Double Oven, press the Upper Oven OFF key or the Lower Oven Off key.

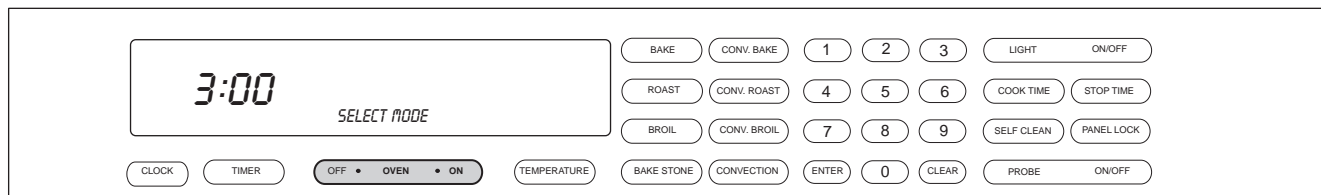

Figure 3-47. To initiate Convection Roast Mode, Press the Oven ON key. For Double Oven, press the Upper Oven ON key or the Lower Oven ON key.

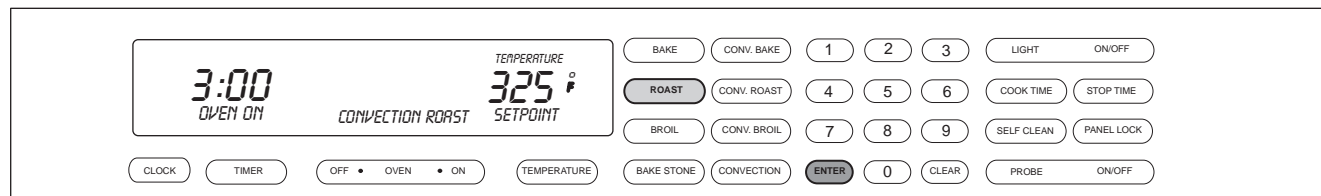

Figure 3-48. Press the CONVECTION ROAST key. A preset temperature of 325°F will be shown in the display. The oven begins to heat after 5 seconds or by pressing the ENTER key.

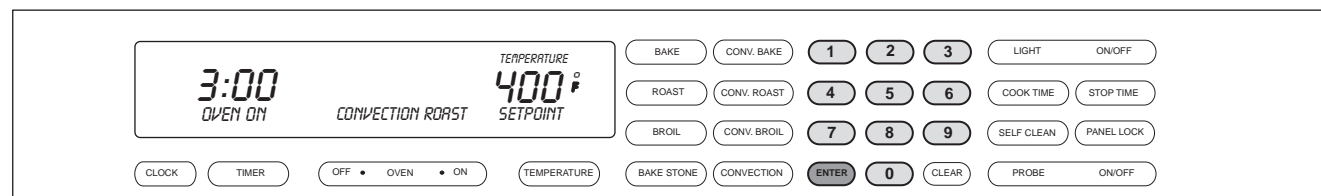

Figure 3-49. To change the preset temperature, immediately press the number keys to enter a new temperature. Then, press the ENTER key.

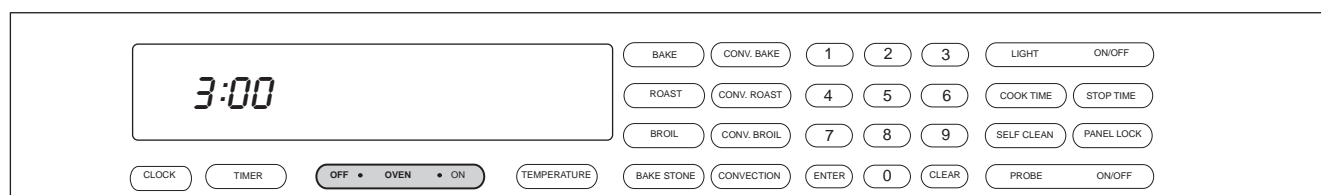

Figure 3-50. To exit the CONVECTION Roast Mode, press the Oven OFF key. For Double oven, press the Upper Oven OFF key or the Lower Oven OFF key.

Bake Stone Mode

In the Bake Stone Mode a specially designed oven rack and heating element are used along with a ceramic stone. Mounted directly underneath the ceramic bake stone is a heating element. This bake stone element along with the convection fans and the broil element help produce a hot enough environment necessary to cook on the ceramic stone.

In this mode the bake stone element is on 58 percent of the time and the broil element is on 42 percent of the time. The convection fans are on 42 percent of the time, sequential in this mode. To use the Bake Stone, remove all oven racks from the oven. Remove the bake stone element plug, located on the back wall of the oven cavity and just below the convection fan baffle plate. Insert the bake stone element into the receptacle. Slide the bake stone rack onto the rack guide number one position. Place the bake stone on the rack with its lip hanging over the front edge of the rack.

NOTE: The oven should always be preheated in this mode. The oven will chime after the oven reaches preheat temperature.

NOTE: On units Starting with serial #16000000, the heating element and receptacle have been eliminated.

To initiate Bake Stone Mode, the oven must be OFF. First press the Oven ON key. (See Figure 3-51). For Double Ovens press the Upper Oven ON key or the Lower Oven ON key. Now, press the BAKE STONE key. A preset temperature of 400°F is shown in the display. The oven begins to heat after 5 seconds or by pressing the ENTER key. (See Figure 3-52). To change the temperature from 400°F, immediately enter another temperature using the number keys. Then, press the ENTER key. (See Figure 3-53). To exit the Bake Stone Mode, press the Oven OFF key. (See Figure 3-54). For the Double Oven, press the Upper Oven OFF key or the Lower Oven Off key.

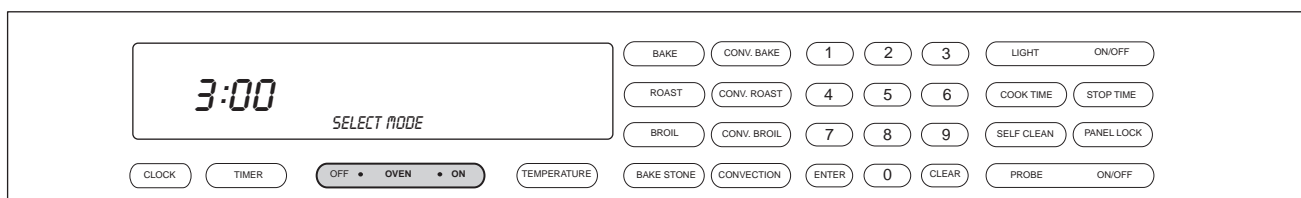

**Figure 3-51. To initiate Bake Stone Mode, Press the Oven ON key.
For Double Oven, press the Upper Oven ON key or the Lower Oven ON key.**

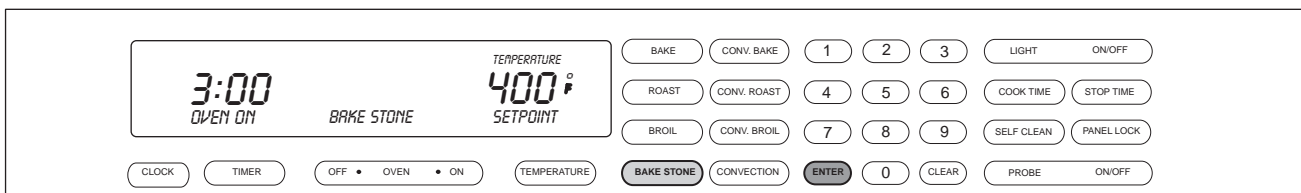

**Figure 3-52. Press the BAKE STONE key. A preset temperature of 400°F will be shown in the display.
The oven begins to heat after 5 seconds or by pressing the ENTER key.**

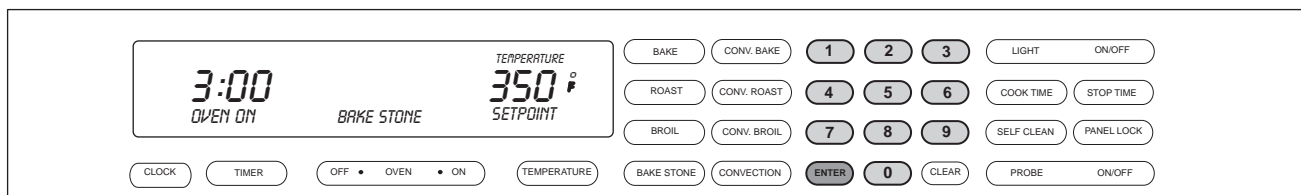

**Figure 3-53. To change the preset temperature, immediately press the number keys to enter a new temperature.
Then, press the ENTER key.**

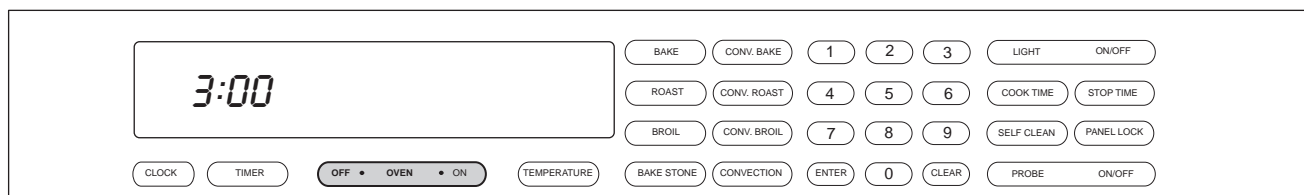

**Figure 3-54. To exit the BAKE STONE Mode, press the Oven OFF key.
For Double oven, press the Upper Oven OFF key or the Lower Oven OFF key.**

Dehydration Feature

This feature allows for slowly drying out food for preservation and other cooking uses. This requires an optional accessory package.

To initiate the Dehydration Feature, the oven must be OFF. First press the Oven ON key. (See Figure 3-55). For Double Ovens press the Upper Oven ON key or the Lower Oven ON key. Now, press and hold the CONVECTION key for 3 seconds. A preset temperature of 160°F is shown in the display. The oven begins to heat after 5 seconds or by pressing the ENTER key. (See Figure 3-56). To change the temperature from 160°F, immediately enter another temperature using the number keys. Then, press the ENTER key. (See Figure 3-57). To exit the Dehydration Mode, press the Oven OFF key. (See Figure 3-58). For the Double Oven, press the Upper Oven OFF key or the Lower Oven Off key. *Dehydration is between 110°F - 160°F (43.3°C - 71.1°C).*

NOTE: Never preheat for Dehydration Feature.

NOTE: Optional accessory package, not supplied with unit must be used.

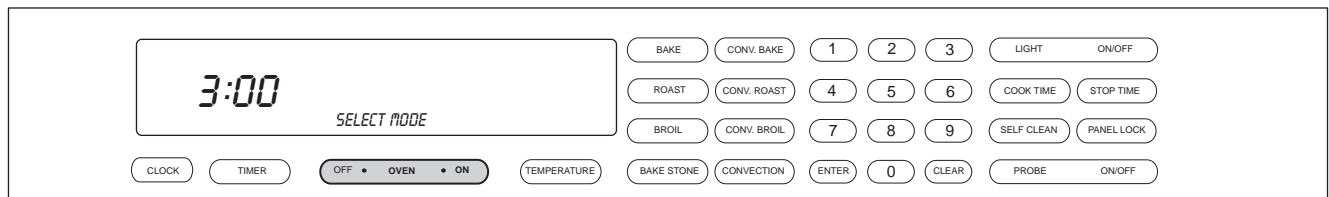

Figure 3-55. To initiate Dehydration Feature, Press the Oven ON key. For Double Oven, press the Upper Oven ON key or the Lower Oven ON key.

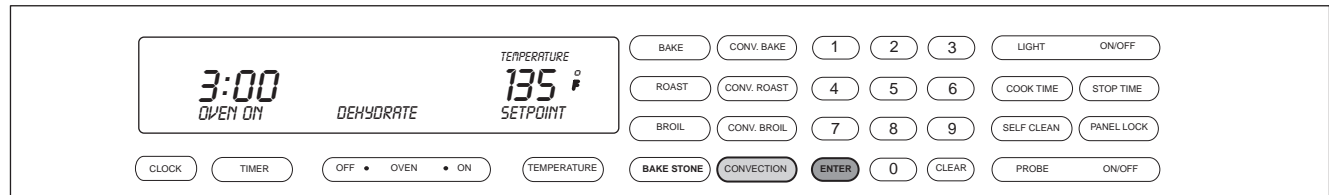

Figure 3-56. Press and Hold the CONVECTION key for 3 seconds or press CONVECTION and enter a temperature within range. A preset temperature of 160°F will be shown in the display. The oven begins to heat after 5 seconds or by pressing the ENTER key.

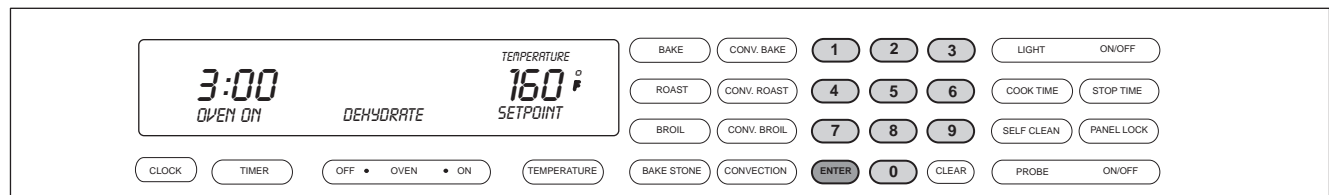

Figure 3-57. To change the preset temperature, immediately press the number keys to enter a new temperature. Then, press the ENTER key.

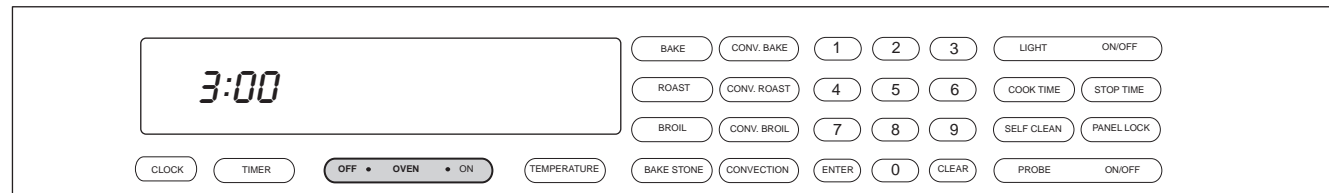
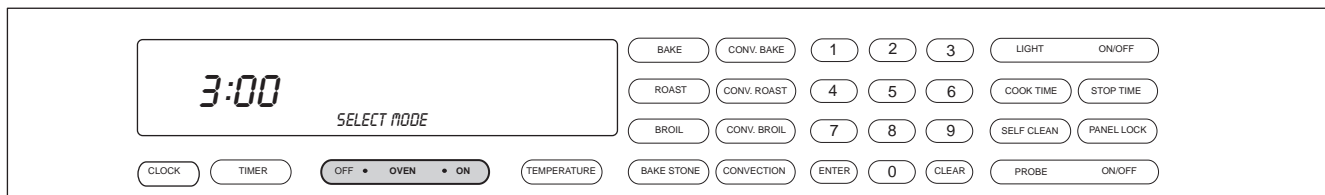

Figure 3-58. To exit the Dehydration Feature, press the Oven OFF key. For Double oven, press the Upper Oven OFF key or the Lower Oven OFF key.

Proof Feature

How PROOF feature works: A combination of Broil, Convection and Bake elements are used to heat and balance the air to maintain temperature. This feature is ideal for proofing bread dough. The oven does not allow the temperature to be set above 110°F (43.3°C). If the oven temperature is above 130°F(55°C), "HOT" will be indicated on the control panel. The user should open the oven door to allow the oven to cool down below 120°F(50°C) to prevent from destroying the yeast.

To initiate PROOF Feature, the oven must be OFF. First press the Oven ON key. (See Figure 3-59). For Double Ovens press the Upper Oven ON key or the Lower Oven ON key. Now, press and hold the BAKE key for 3 seconds. A preset temperature of 85°F (29.4°C) is shown in the display. The oven begins to heat after 5 seconds or by pressing the ENTER key. (See Figure 3-60). To change the temperature from 85°F, immediately enter another temperature using the number keys. Then, press the ENTER key. (See Figure 3-61). To exit the PROOF Feature, press the Oven OFF key. (See Figure 3-62). For the Double Oven, press the Upper Oven OFF key or the Lower Oven Off key. *PROOF is between 85°F - 110°F (29.4°C - 43.3°C).*



**Figure 3-59. To initiate Proof Mode, Press the Oven ON key.
For Double Oven, press the Upper Oven ON key or the Lower Oven ON key.**

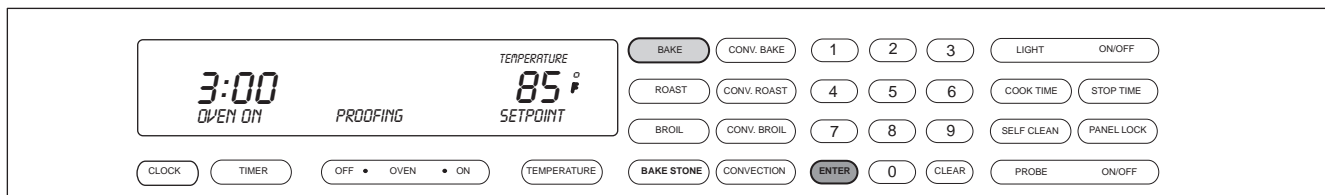

Figure 3-60. Press and Hold the CONVECTION key for 3 seconds or press CONVECTION and enter a temperature within range. A preset temperature of 85°F will be shown in the display. The oven begins to heat after 5 seconds or by pressing the ENTER key.

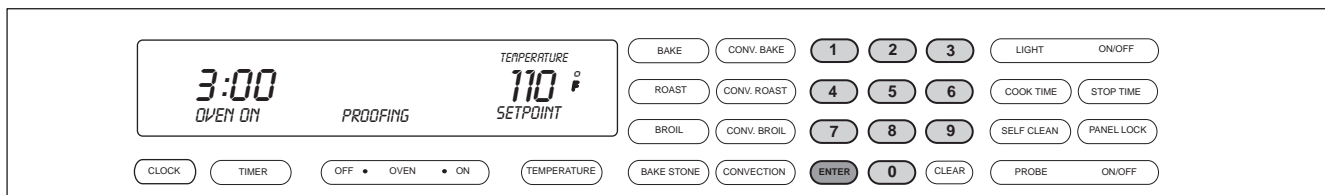
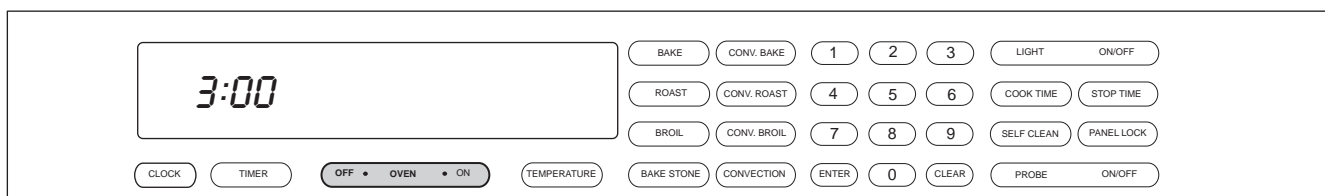

Figure 3-61. To change the preset temperature, immediately press the number keys to enter a new temperature. Then, press the ENTER key.



**Figure 3-62. To exit the Proof Mode, press the Oven OFF key.
For Double oven, press the Upper Oven OFF key or the Lower Oven OFF key.**

Panel Lock

When the electronic control panel is visible, the oven is operational. When initiating the panel lock feature all modes and key pads will be non functional except oven OFF touch pad and PANEL LOCK touch pad. This keeps it child safe and prevents oven from accidentally being turned on.

Setting Panel Lock:

- Press and hold Panel Lock touch pad for 3 seconds. Two beeps will be heard and oven display will show PANEL LOCKED for 5 seconds.
- To exit Panel Lock, press and hold Panel Lock touch pad for 3 seconds. A beep will be heard and oven display will read PANEL UNLOCKED for 5 seconds.

Time of Day Clock

Immediately after the oven is powered up, set the 12-hour clock to the current time of day. It must be reset after a power failure. The clock is visible on the panel during all modes. If the timer is set, the clock will not be visible in the display window.

Setting the time of day:

- Touch Clock pad.
- Touch Number pads to set current time of day.
- Touch Clock or Enter to start clock.

DIAGNOSTIC MODE

Diagnostic Mode allows the Service Technician to inspect the functionality of the Oven Controller and Relay boards. Entering a key combination on the oven touch pad will allow the Service Technician to enter Diagnostic Mode. In Diagnostic Mode the last seven errors that have occurred to the oven controlling all the relays on the relay board and controller feedback of temperature and switches will be displayed.

NOTE: The Double Oven stores a total of fourteen errors. Seven errors for the Upper Oven and seven errors for the Lower Oven.

NOTE: Diagnostic Mode will end two minutes after last key stroke or by pressing the CLEAR key.

Double Wall Oven Keyboard:

The Double Wall Oven controls consist of 1 double oven controller, 2 relay boards, 1 upper oven display, 1 lower oven display, 1 double wall oven keyboard, 1 stepper motor control board, 1 MRCP Drive Plate.

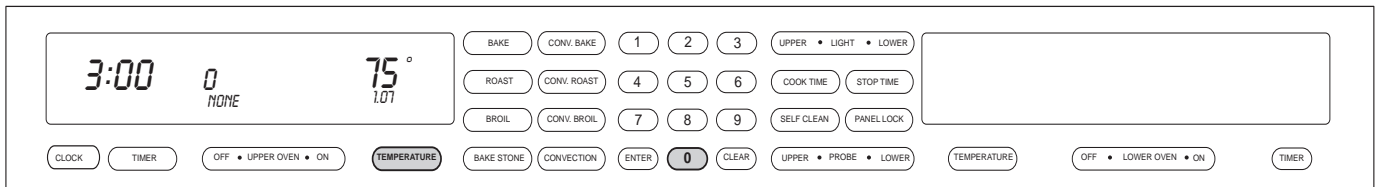

Figure 3-63. Double Wall Oven Keyboard

Single Wall Oven Keyboard:

The Single Wall Oven controls consist of 1 single oven controller, 1 relay board, 1 upper oven display, 1 single wall oven keyboard, 1 stepper motor control board, 1 MRCP Drive Plate.

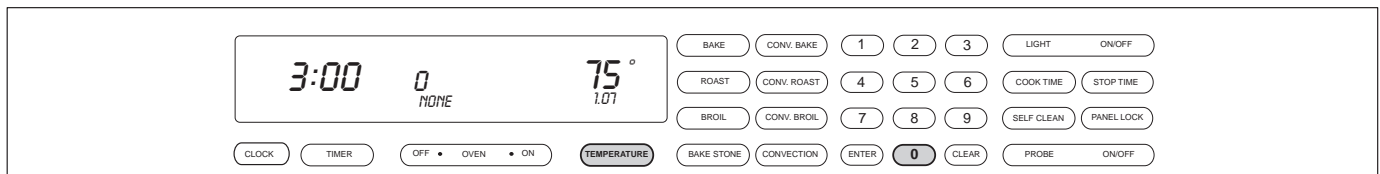

Figure 3-64. Single Wall Oven Keyboard

INITIATING DIAGNOSTIC MODE

UPPER OVEN

To initiate Diagnostic Mode for the Upper Oven, the oven must be OFF. Then press and hold the TEMPERATURE key and the 0 “ZERO” key for 3 seconds, then release both keys. (See Figure 3-65).

NOTE: Diagnostic Mode will end 2 minutes after last key stroke or when the CLEAR key is pressed.

LOWER OVEN

To initiate Diagnostic Mode for the Lower Oven, the oven must be OFF. Then press and hold the TEMPERATURE key and the 0 “ZERO” key for 3 seconds, then release both keys. (See Figure 3-66).

NOTE: Diagnostic Mode will end 2 minutes after last key stroke or when the CLEAR key is pressed.

SINGLE OVEN

To initiate Diagnostic Mode for the Single Oven, the oven must be OFF. Then press and hold the TEMPERATURE key and the 0 “ZERO” key for 3 seconds, then release both keys. (See Figure 3-67).

NOTE: Diagnostic Mode will end 2 minutes after last key stroke or when the CLEAR key is pressed.

To clear any error codes, the oven must be in diagnostic mode. Pressing the COOK TIME and STOP TIME key, at the same time will clear the error codes recorded. This must be performed after the unit is serviced.

To toggle from one error code to another, the ENTER key must be pressed. The ENTER key will need to be pressed seven times to make sure there are no other codes.

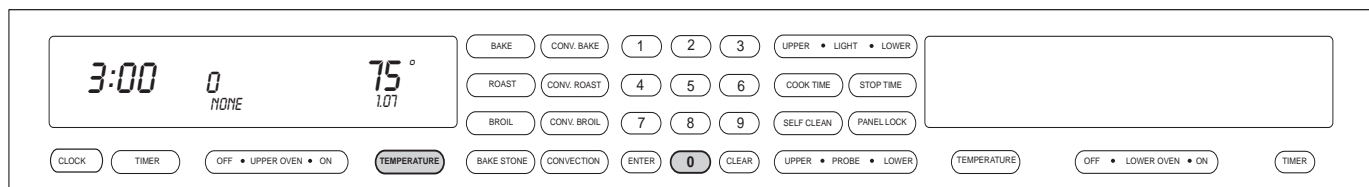

Figure 3-65. Initiate Diagnostic Mode Upper Oven - Press and hold the TEMPERATURE key and the “0” key.

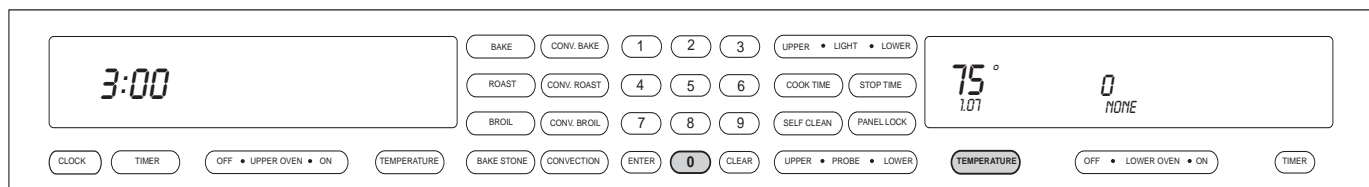

Figure 3-66. Initiate Diagnostic Mode Lower Oven - Press and hold the TEMPERATURE key and the “0” key.

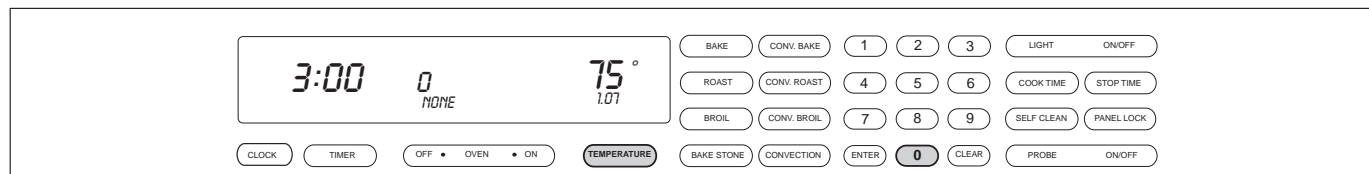

Figure 3-67. Initiate Diagnostic Mode Single Oven - Press and hold the TEMPERATURE key and the “0” key.

POSSIBLE ERROR INDICATORS

The last occurring error will be shown in the text area of the Display board. Pressing the ENTER key will cycle through the last occurring seven errors for the oven. The Double Wall Oven stores a total of 14 errors, seven for the upper oven and seven for the lower oven. Pressing the COOK TIME and STOP TIME keys will clear the last seven errors for the oven.

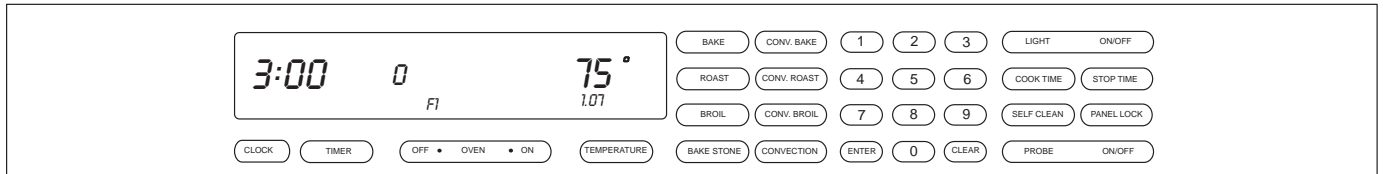

Figure 3-68. F1 - Door lock or unlock switches not sensed within 60 seconds while driving the door lock motor. This error indicates a motor door lock (MDL) failure.

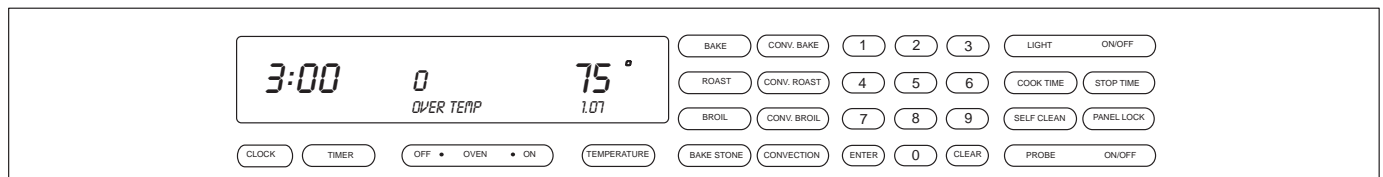

Figure 3-69. Over Temperature Alarm - Over temperature occurs when the oven reaches a temperature of 630°F for an unlocked door and 930°F for a locked door. This error indicates a runaway temperature.

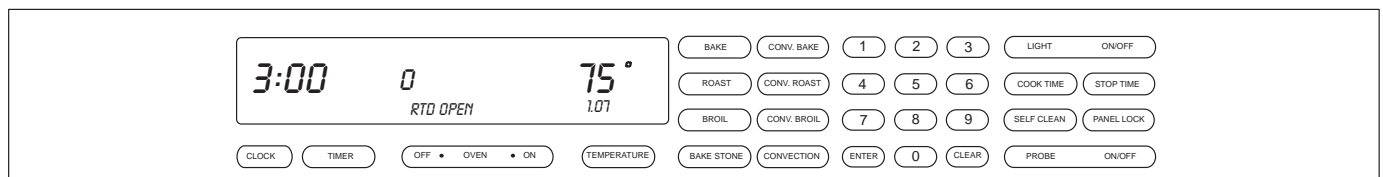

Figure 3-70. Open Circuit Detected on RTD Oven Sensor - This error may indicate an RTD failure.

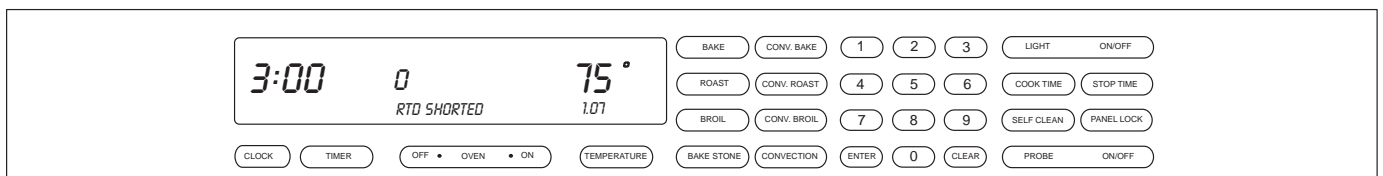

Figure 3-71. Shorted Circuit Detected on RTD Oven Sensor - This error may indicate an RTD failure.

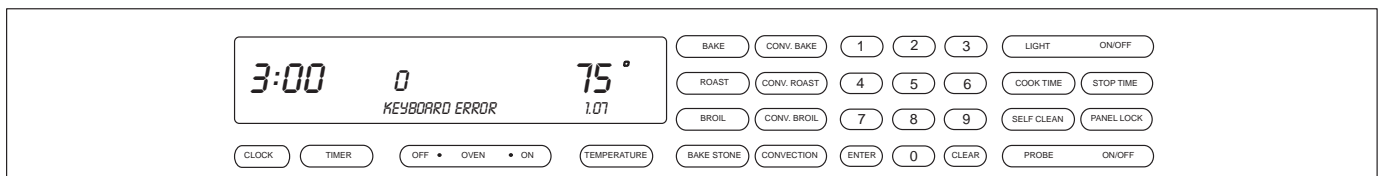

Figure 3-72. Key Communications Error - This error is reported by display board.

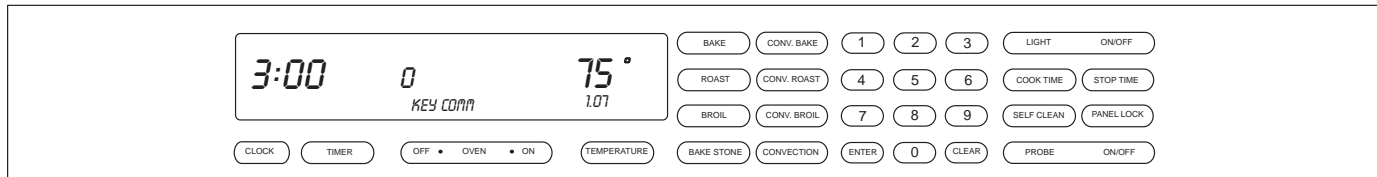

Figure 3-73. Keyboard Reporting Errors on Key(s) - This error indicates a failure between the Oven Controller and the Head Assembly. (Reported by Display)

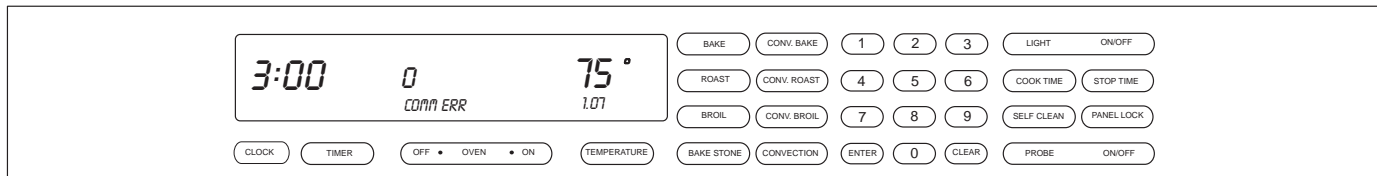

Figure 3-74. Communication Lost with the Oven Controller Board - This error indicates a Head Assembly failure or connecting cable fault. (Reported by Oven Controller)

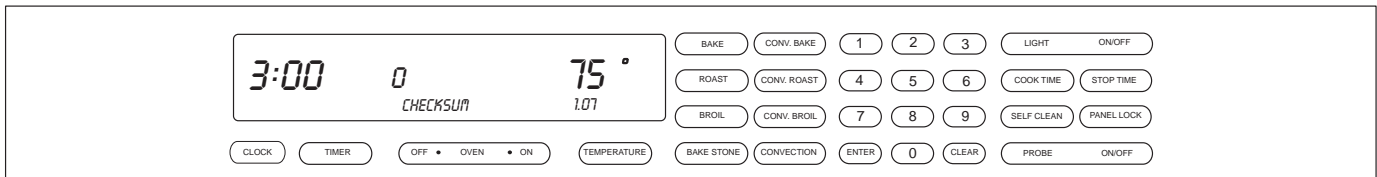

Figure 3-75. Eeprom Checksum is incorrect - Checked at power up, and when OVEN OFF key is pressed. This error indicates an Oven Controller failure.

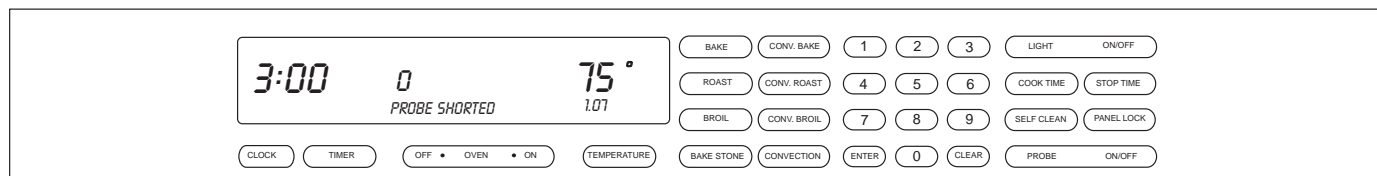

Figure 3-76. Meat Probe Sensed as being Shorted - This error occurs if the meat probe is not inserted all of the way. This error may indicate a meat probe failure.

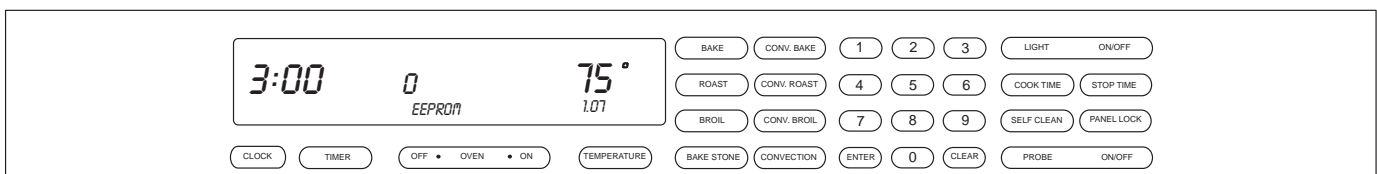

Figure 3-77. Cannot Read or Write to the Eeprom - This error indicates an Oven Controller failure.

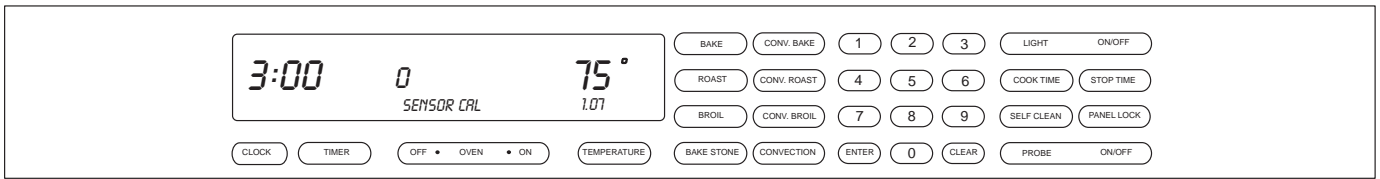

Figure 3-78. Analog to Digital Error during Calibration Phase - This error indicates an Oven Controller failure.

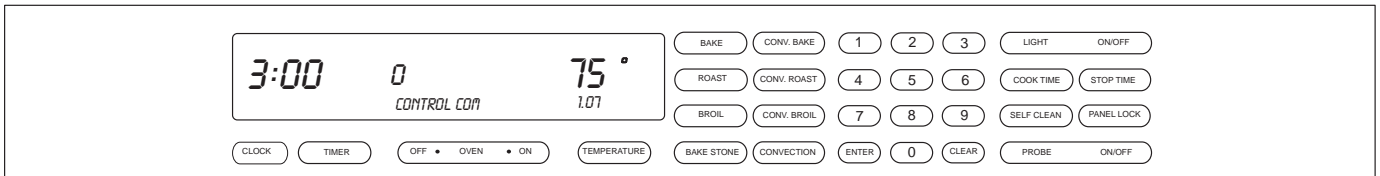

Figure 3-79. Communication Lost with the Oven Control Board - This error indicates a Oven Controller failure. (Reported by the Display)

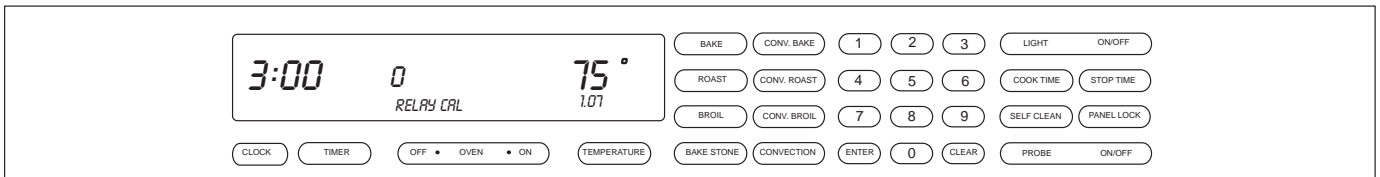

Figure 3-80. Relay Phase Calibration Failed - This error indicates a relay timing problem with the relay board.

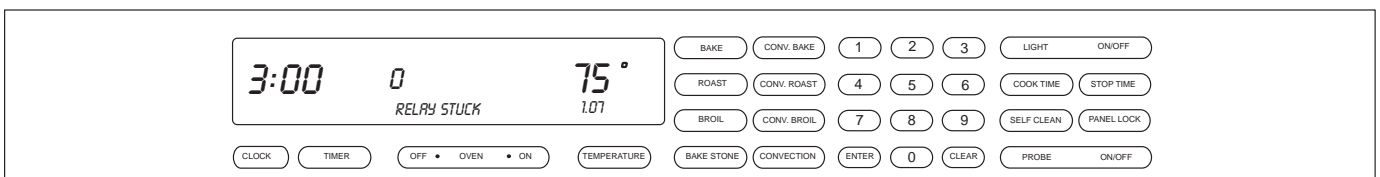

Figure 3-81. Power Relay Shorted - Sensed as being closed when it should be open by current sensor on the oven controller. This error indicates a failure of a Relay Board.

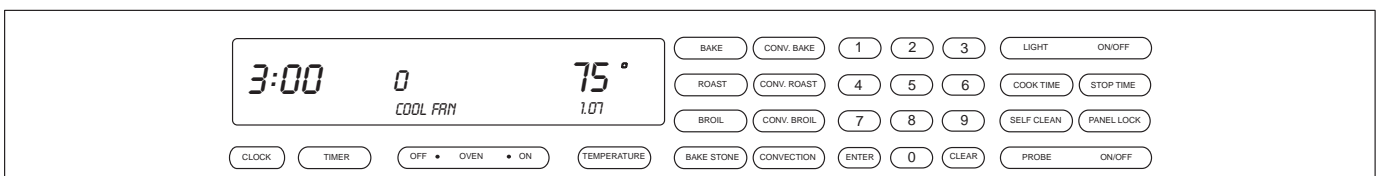

Figure 3-82. Cooling Fan failure. Error indicates a failure of the cooling fan or circuit.

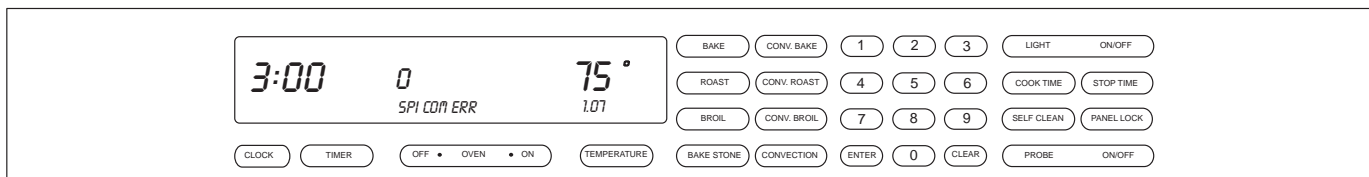

Figure 3-83. SPI communication lost with main controller reported by the display head, indicating the control head cannot find the main controller. This error would indicate a bad main controller.

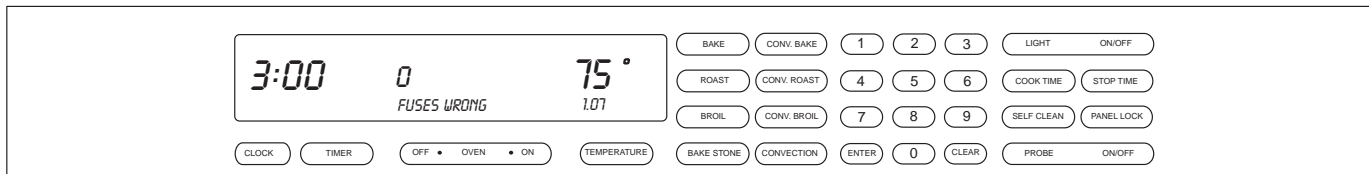

Figure 3-83. Controller configurations settings incorrect or code protection is disabled. "OFF" clears error. If error will not clear, replace main controller.

TESTING THE OVEN RELAY BOARD

Element Testing

First access Diagnostic Mode. Once in Diagnostic Mode, the Technician can press a key to activate an element. The element relay and the double line breaker(dlb) will close to complete a 240/208 VAC circuit through a specific element. If the Oven Controller detects the current running through the closed circuit, OVEN ON will be illuminated on the corresponding display.

NOTE: Diagnostic Mode will end 2 minutes after last key stroke or when the CLEAR key is pressed.

Key Pressed	Relay(s) activated	Display Response
Bake	Inner Bake Element	Oven On Illuminated
Broil	Broil Element	Oven On Illuminated
Bake Stone	Bake Stone Element	Oven On Illuminated
Convection Bake	Outer Bake Element and	Oven On Illuminated
Convection Broil	Right Convection Element	Oven On Illuminated
Convection	Left Convection Element	Oven On Illuminated

Figure 3-84. Element Testing Chart

Fans and Motors

First access Diagnostic Mode. Once in Diagnostic Mode, the technician can press a key to activate a fan or a motor. The fan and motor relays will close to complete a 120 VAC circuit through a specific fan or motor. If the Oven Controller detects the functionality through switches, an indicator will be illuminated on the corresponding display.

NOTE: Diagnostic Mode will end 2 minutes after last key stroke or when the CLEAR key is pressed.

Key Pressed	Relay(s) activated	Action	Display Response
Roast	Motor Door Lock (MDL)	MDL switch in open position	Degree Icon (°) Illuminated
		MDL in transition	Degree and Centigrade Icon Off
		MDL switch in closed position	Centigrade Icon (°C) Illuminated
Convection Roast	Oven Light	Light turns on	Not applicable
Self Clean	Cool Fan Low	Cool Fan Low	COOL FAN LO
0	Cool Fan High	Cool Fan High	COOL FAN HI
Key 7	Left Convection Fan	Left Convection Fan	L CONV ON
Key 9	Right Convection Fan	Right Convection Fan	R CONV ON
Panel Lock	Fan Apparency logging	Used on units prior to serial number 11100847 which used	"L" = Fan apparency switch Note: No display means no fan apparency switches.

Figure 3-85. Fans and Motors Testing Chart

RTD Testing

First access Diagnostic Mode. Once in Diagnostic Mode, the RTD temperature as read by the Oven Controller is shown in the corresponding display.

NOTE: Diagnostic Mode will end 2 minutes after last key stroke or when the CLEAR key is pressed.

Probe Testing

First access Diagnostic Mode. Once in Diagnostic Mode, the Probe temperature as read by the Oven Controller is shown in the Stop Cook digits in the corresponding display. If the Probe has not been inserted, "0" will be shown as the Probe temperature. If the Probe has not been completely inserted creating a short circuit of the Probe, "998" will be shown as the Probe temperature.

NOTE: Diagnostic Mode will end 2 minutes after last key stroke or when the CLEAR key is pressed.

SECTION 4

COMPONENT ACCESS AND REMOVAL

COMPONENT ACCESS AND REMOVAL

This section explains how to access and remove components from a Wolf wall oven. Depending on which component you are going to access or remove in the following sections, you may have to remove other components first. Refer to the appropriate section in this manual that explains how to access and remove those various components. When reassembling, just reverse the steps that were used to access and remove the components.

NOTE: Before attempting to access or remove any components from a Wolf appliance, take note of the **WARNINGS** and **CAUTIONS** below.

⚠ WARNING

TO AVOID ELECTRIC SHOCK, POWER TO THE UNIT MUST BE DISCONNECTED WHENEVER SERVICING AND/OR ACCESSING COMPONENTS.

KEEP IN MIND THAT OVEN SURFACES AND COMPONENTS GET HOT DURING USE OF THE APPLIANCE.

IF IT IS NECESSARY TO REMOVE A UNIT FROM ITS INSTALLATION, REMEMBER THAT THE UNIT COULD TIP FORWARD WHEN PULLED BEYOND ITS INSTALLATION, RESULTING IN SERIOUS INJURY OR DEATH. PULLING A UNIT FROM ITS INSTALLATION SHOULD ONLY BE PERFORMED BY AN AUTHORIZED SERVICE TECHNICIAN OR INSTALLER.

⚠ CAUTION

When working on the oven and components, be careful when handling sheet metal parts. There may be sharp edges present.

If removing or disconnecting the door hinges, remember it could recoil quickly when released.

CONTROL PANEL COMPONENTS:

⚠ WARNING

TURN OFF THE ELECTRICAL POWER GOING TO THE OVEN BEFORE SERVICING.

IN ORDER TO REMOVE THE CONTROL PANEL AND COMPONENTS BEHIND IT, THE OVEN WILL HAVE TO BE PULLED OUT APPROXIMATELY 12 INCHES FROM ITS INSTALLATION AND THE FRONT OVEN TOP PANEL WILL NEED TO BE REMOVED.

Control Panel Assembly Removal

Unplug the control panel flex strip from the oven controller. Extract the screws that secure the right side control panel mounting plate and remove the plate. (See Figure 4-1).

Now, slide the control panel assembly with flex strip out from the c-channels. (See Figure 4-2).

NOTE: Make sure you don't lose the plastic flange bearings located on each end of the control panel assembly.

Control Panel Drive Motor Assembly Removal

Unplug the wire harness connector for the drive motor from the stepper motor control board. Now, extract the screws that secure the drive motor assembly to the c-channels. (See Figure 4-3). Now, slide the drive motor assembly from the unit. (See Figure 4-4).

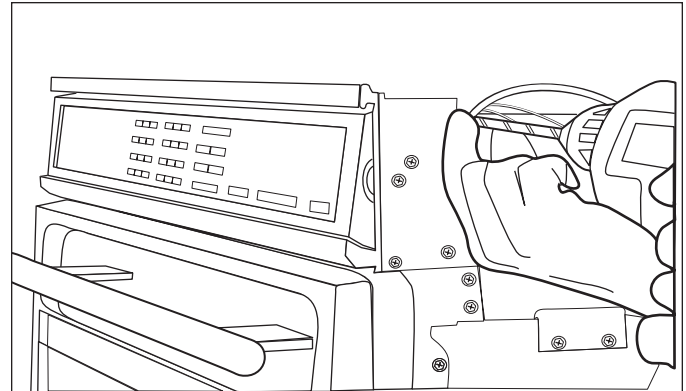

Figure 4-1. Control Panel Removal.

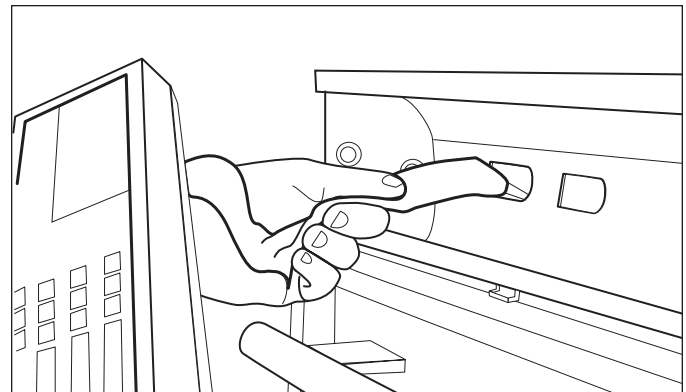

Figure 4-2. Control Panel Removal.

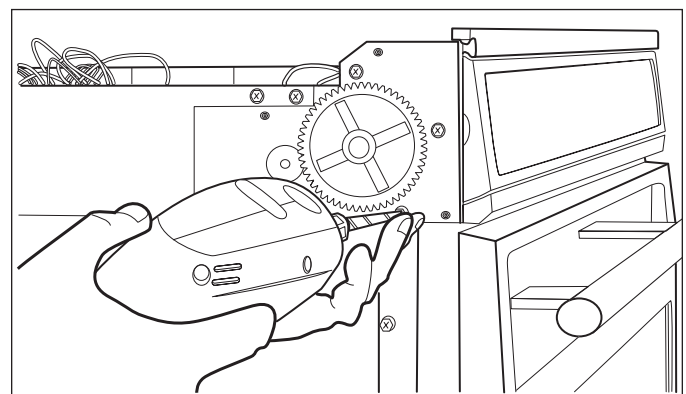

Figure 4-3. Control Panel Drive Motor Removal.

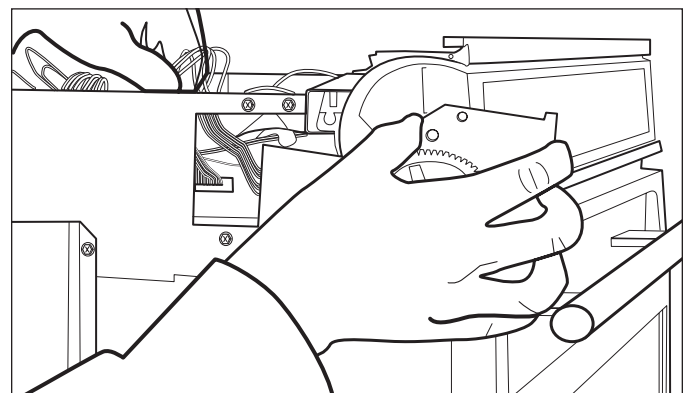

Figure 4-4. Control Panel Drive Motor Removal.

C-Channel Top and Bottom Removal

Unplug the switch actuator wire harness connector from the stepper motor control board and pull the wire harness out from its routing. Next, extract the screws that secure the c-channels to the mounting bracket. (See Figure 4-5). Now, tilt the c-channels down slightly and lift off the mounting pins and remove from the unit. (See Figure 4-6). Now, you can separate the top and bottom c-channel by sliding the two apart.

Switch Actuator and Plunger Removal

The switch actuator and plunger is mounted to the bottom c-channel. Once the c-channels have been removed, extract the two screws from the switch actuator bracket and remove. (See Figure 4-7). Now, slide the plunger out from the c-channel. (See Figure 4-8).

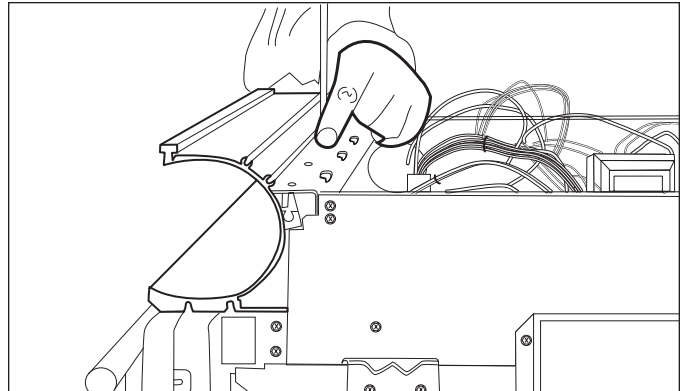

Figure 4-5. C-Channel Top and Bottom Removal.

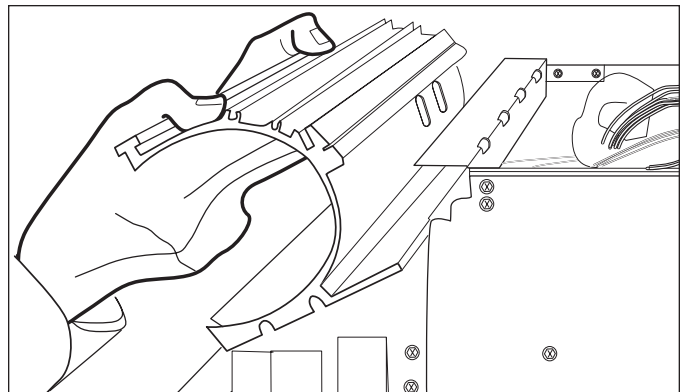

Figure 4-6. C-Channel Top and Bottom Removal.

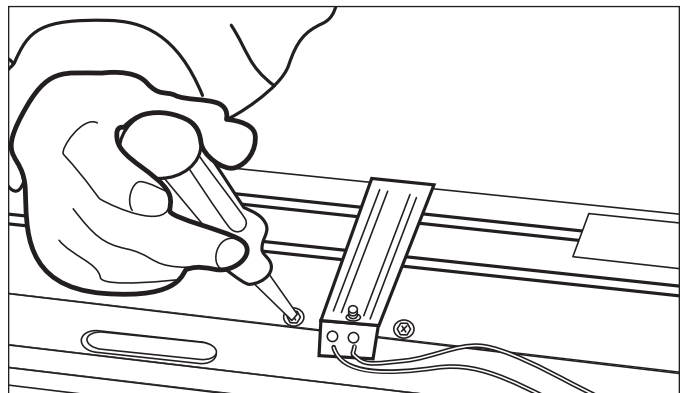

Figure 4-7. Switch Actuator Removal.

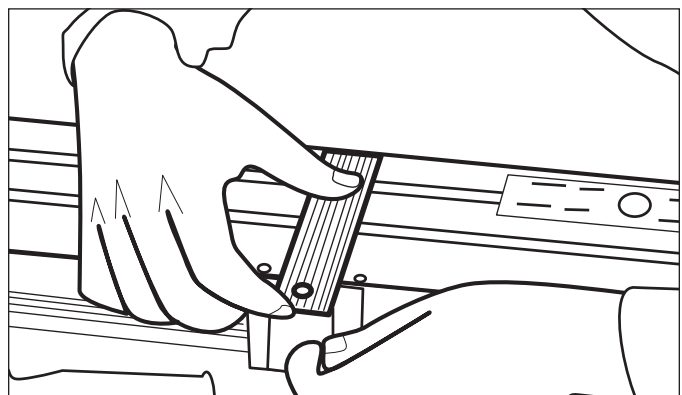

Figure 4-8. Switch Actuator Plunger Removal.

COMPONENTS BEHIND CONTROL PANEL:

⚠ WARNING

TURN OFF THE ELECTRICAL POWER GOING TO THE OVEN BEFORE SERVICING.

IN ORDER TO REMOVE THE CONTROL PANEL AND COMPONENTS BEHIND IT, THE OVEN WILL HAVE TO BE PULLED OUT APPROXIMATELY 12 INCHES FROM ITS INSTALLATION AND THE FRONT OVEN TOP PANEL WILL NEED TO BE REMOVED.

Latch Cover Removal

Extract the two screws that mount the latch cover to the mounting plate. (See Figure 4-9). Now, lift latch cover from unit.

Motorized Door Latch Assembly Removal

Begin by opening the oven door. Extract the screws and remove the face plate. Now, extract the two screws that secure the latch assembly to the mounting bracket (located just below the control panel). (See Figure 4-10). Now, lift the rear of the latch assembly up from the mounting slots. Then, slide the latch assembly out so you can unplug the wires from the micro switches and lock motor. (See Figure 4-11).

Thermal Limiter Removal

NOTE: Double Oven lower

To remove the limit switch you need to remove the center trim and latch assembly. Extract the two screws that secure the limit switch. Lift the limit switch out and disconnect the wires.

NOTE: Access and removal of limit switch can also be gained from the rear of the unit by removing the lower cooling fan assembly. This is the recommended procedure.

Thermo Limiter Removal

NOTE: Single Oven & Double oven upper cavity

The thermo limiter is mounted on the back panel above the left convection fan. To remove the thermo limit, remove unit from its installation, Then disconnect the wiring to the limit and remove. (See Figure 4-12)

NOTE: The thermo limiter can be reset if it trips. If the thermo limiter has been tripped, you can reset it by removing the left convection baffle and convection fan from the oven cavity in a single oven or upper cavity in a double oven. Reach through the left convection fan opening. Limiter is located directly above the opening and to the right. You can now reset the limit.

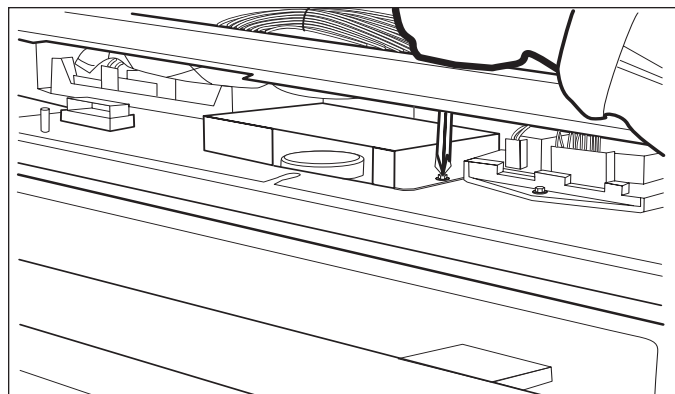

Figure 4-9. Latch Cover Removal.

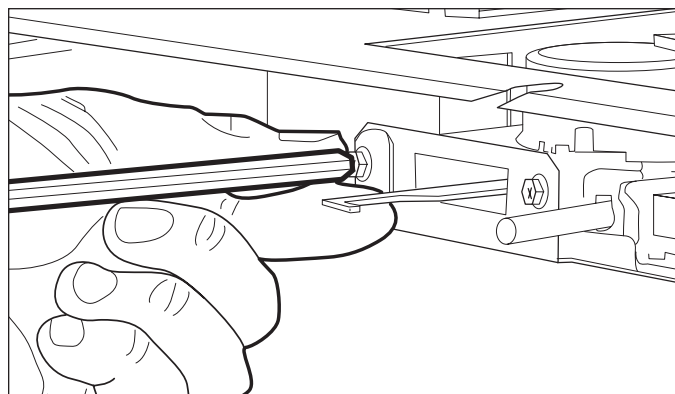

Figure 4-10. Motorized Door Latch Removal.

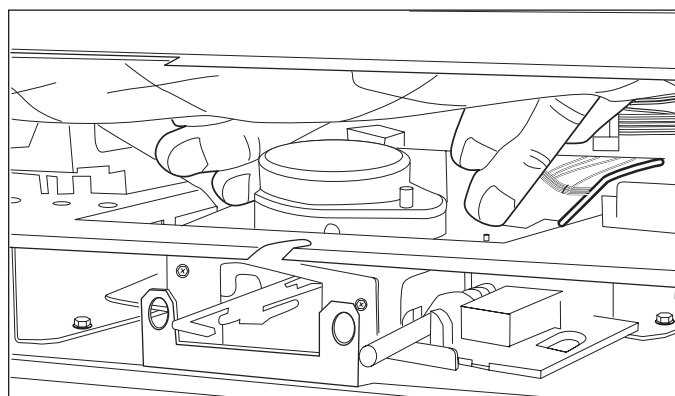

Figure 4-11. Motorized Door Latch Removal.

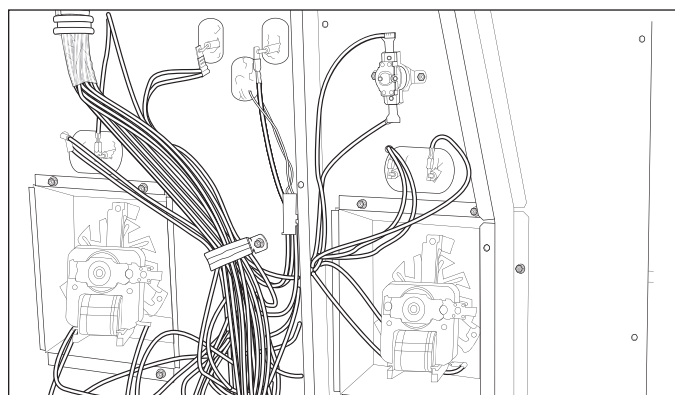

Figure 4-12. Limit Switch Removal.

Oven Controller Removal

The oven control board is located next to the control panel drive motor assembly. Remove all wire connectors mounted to the control board.

NOTE: You may want to mark the wire connectors to ensure their proper location when reattaching to the board.

Now, extract the four screws that secure the control board and lift out. (See Figure 4-13).

Stepper Motor Control Board Removal

Extract the screws that secure the oven control board to the mounting plate. (See Figure 4-14). Now, lift the board up slightly (where the screw was located) and slide the board towards the center unit. Doing this will release the board mounting tabs from the mounting plate. Next, remove all of the wire connectors from the board and remove. (See Figure 4-15).

NOTE: You may want to mark the location of the wiring to ensure proper placement when reassembling.

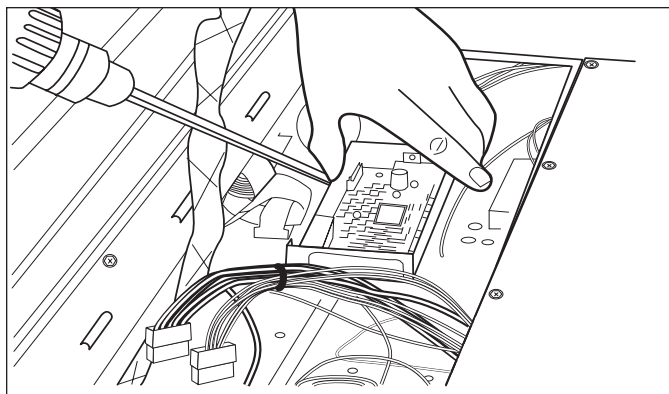

Figure 4-13. Oven Control Board Removal.

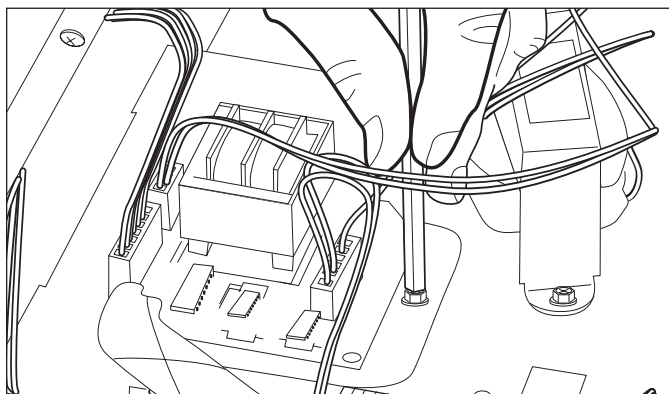

Figure 4-14. Stepper Motor Screw Removal

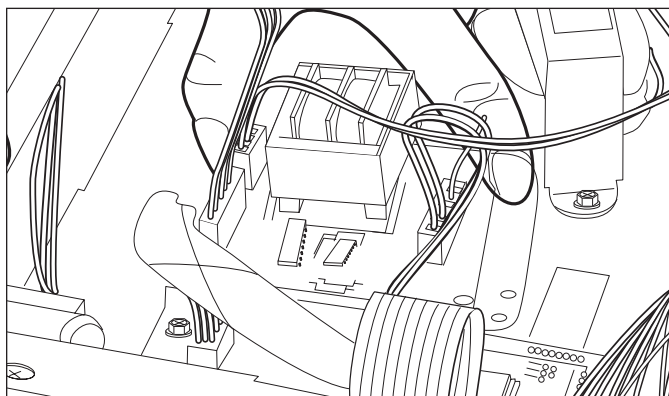

Figure 4-15. Stepper Motor Removal.

Relay Board Removal

Extract the screw located at the front of the relay board. (See Figure 4-16). Then, lift the front of the relay board up slightly and slide the relay board towards the front of the unit. This will disengage the tabs of the relay mounting bracket from the mounting plate. (See Figure 4-17).

NOTE: If working on a double oven, you may have to remove both relay boards to have enough room to disconnect the wiring.

Now, disconnect the wiring from the relay board and remove.

NOTE: The rear top oven panel will also need to be removed for access to the following components.

⚠ WARNING

IN ORDER TO REMOVE THE FOLLOWING COMPONENTS, THE ENTIRE OVEN WILL HAVE TO BE REMOVED FROM ITS INSTALLATION.

Light Transformer Removal

Disconnect the wiring for the transformer at the molex connectors. Now, extract the two screws that secure the transformer to the mounting plate and lift out from unit. (See Figure 4-18).

Light Fuse Removal

The light fuse is located just behind the molex connector for the light transformer. To remove, push and turn the fuse holder together and separate the two halves of the fuse holder. Now, remove the fuse from the fuse holder. (See Figure 4-19).

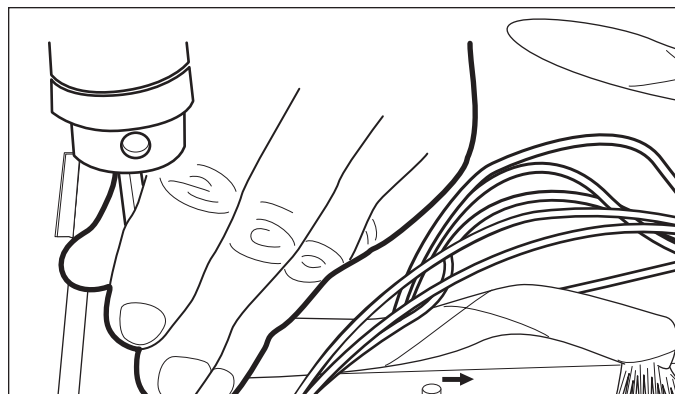

Figure 4-16. Relay Board Removal.

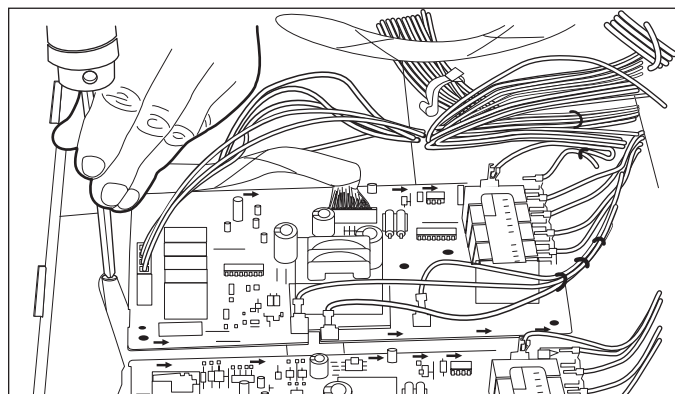

Figure 4-17. Relay Board Removal.



Figure 4-18. Light Transformer Removal.

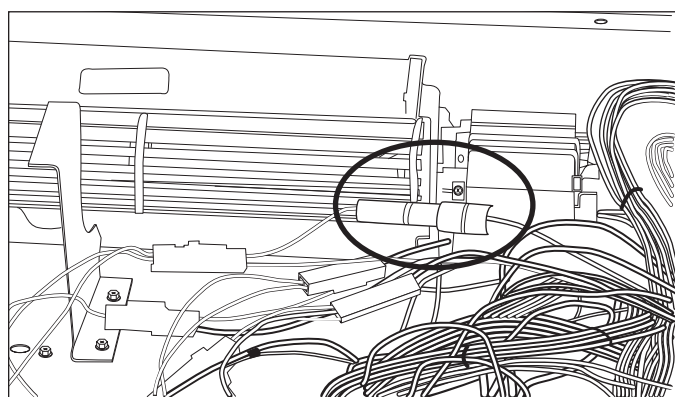

Figure 4-19. Light Fuse Removal.

Upper Cooling Fan Removal

First, remove the air diverter bracket located in front of the cooling fan. (See Figure 4-20). Next, extract the three screws at the rear of the unit which secures the cooling fan to the unit. (See Figure 4-21). Now, lift the cooling fan up and disconnect the wiring from the fan motor terminals and remove. (See Figure 4-22).

Terminal Block Removal

NOTE: You may want to mark the location of the wiring to ensure proper placement when reassembling.

Disconnect the wires from the power cord at the terminal block. Now, disconnect the wiring from the terminal connectors on the block. Next, extract the two screws which secure the terminal block to the mounting plate and remove. (See Figure 4-23).

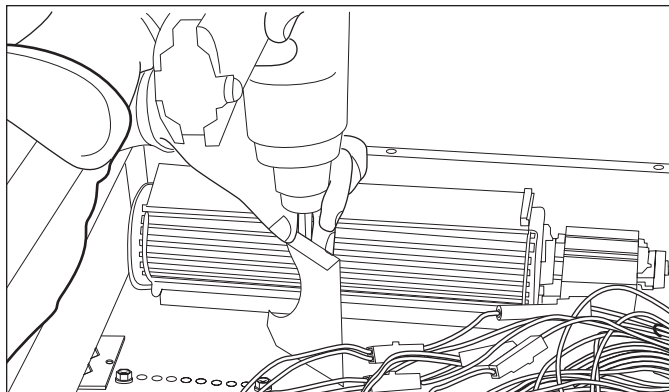

Figure 4-20. Air Diverter Removal.

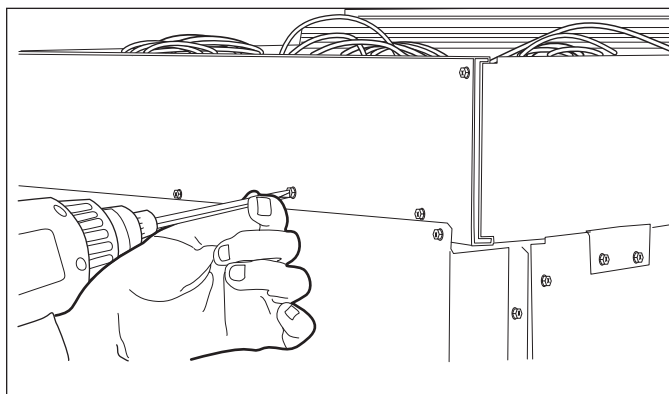

Figure 4-21. Upper Cooling Fan Removal.

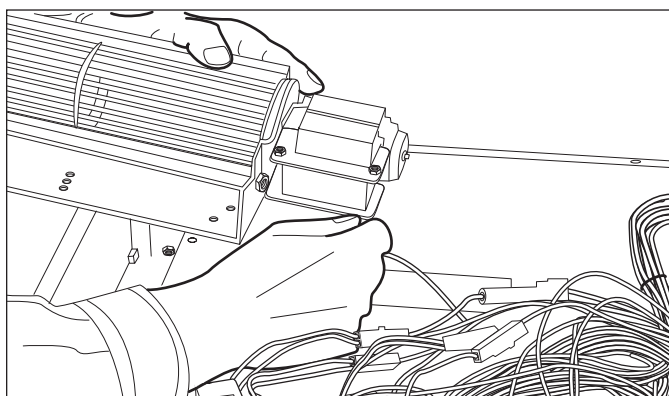

Figure 4-22. Disconnecting Wires from Cooling Fan.

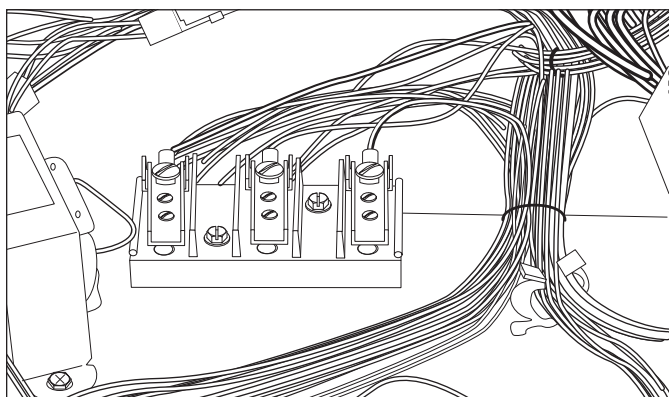

Figure 4-23. Terminal Block Removal .

OVEN CAVITY COMPONENTS:

⚠ WARNING

TURN OFF THE ELECTRICAL POWER GOING TO THE OVEN BEFORE SERVICING.

Left and Right Rack Guide Removal

First, remove oven racks. Then, extract the screws in each corner, top and bottom of the rack guide and lift guide out. (See Figure 4-24).

NOTE: On units starting with serial #16000000 the oven rack guides remove without extracting any screws. Simply lift upwards on the rack to disengage the shoulder screw from the keyhole slot on the rack guide and remove. (See Figure 4-24A)

Oven Lights Removal

To remove the oven lights you will need to remove the oven racks and guides. Next, the light cover will need to be removed by gently pulling the light cover off the light housing. (See Figure 4-25). Now, to remove the light bulb, lift the bulb straight up and out of the light bulb socket.

NOTE: When replacing the light bulb with a new one, wrap a clean cloth around the new bulb so fingerprints are not left on the new bulb. The greasy residue from fingerprints may cause the new bulb to burn out prematurely.

Convection Baffle Plate Removal

First, the racks and rack guides will need to be removed. Now, extract the screws in each corner, the top and bottom of the convection baffle plate and remove. (See Figure 4-26).

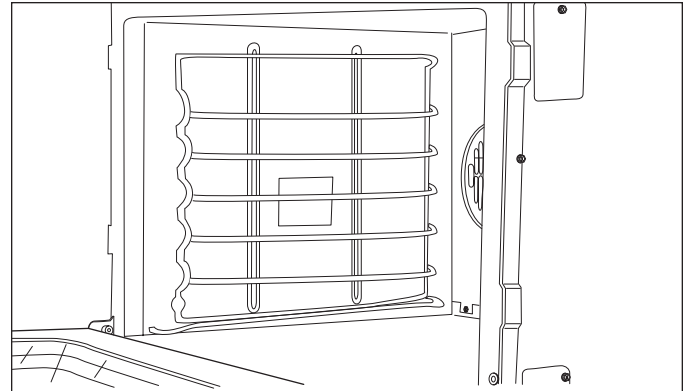

Figure 4-24. Rack Guide Removal.

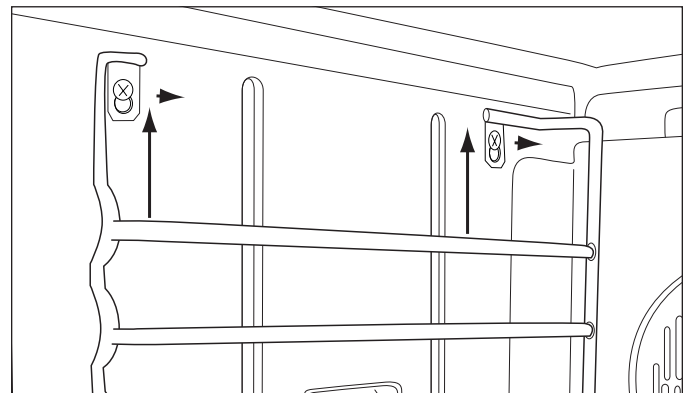

Figure 4-24A. Removable Rack Guides.

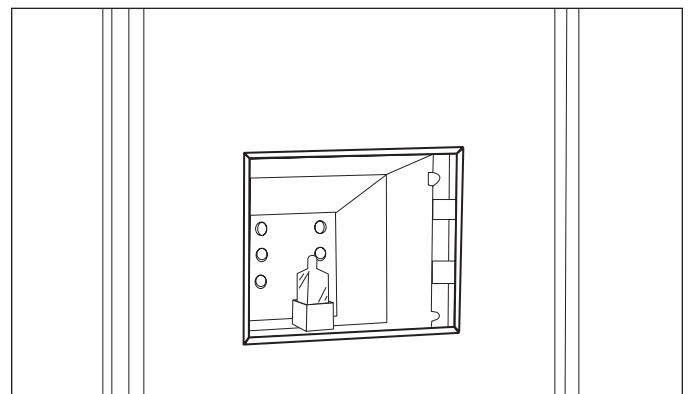

Figure 4-25. Oven Light Removal.

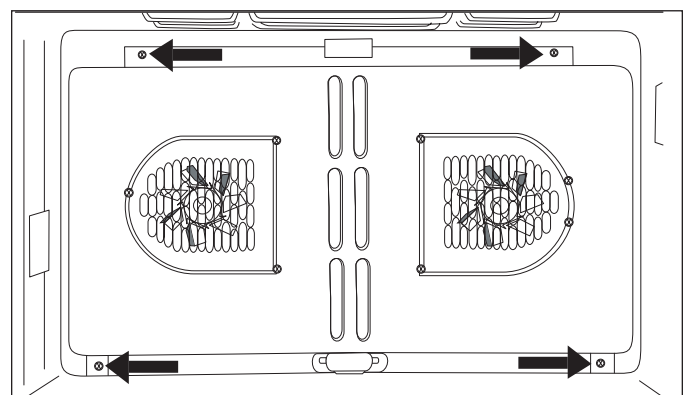

Figure 4-26. Convection Baffle Removal.

Probe Cover and Probe Switch Removal

To remove the probe cover, first you will need to raise the probe cover up. Now, using a wrench, loosen and remove the nut. Now, the cover can be removed. (See Figure 4-27).

NOTE: To remove the probe switch the unit will need to be pulled from its installation approximately 8 inches. Next, extract the screw and remove the access panel for the probe switch. Now, pull the switch from the oven cavity and disconnect the wires from the switch terminals. (See Figure 4-28).

Temperature Sensor Removal

Extract the two screws which secure the sensor to the oven cavity. (See Figure 4-29). Next, carefully pull the sensor with wire leads straight out from the oven cavity, until the molex connector is inside the oven cavity. (See Figure 4-30). Now, unplug the molex connector and remove the temperature sensor.

NOTE: When the molex connector is disconnected, make sure the male end of the connector doesn't fall back into the hole. If it does, the unit may have to be pulled out from its installation in order to reconnect the molex connectors for the sensor.

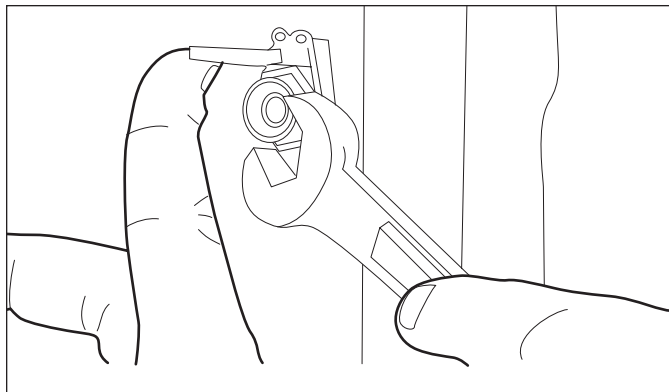

Figure 4-27. Probe Cover Removal.

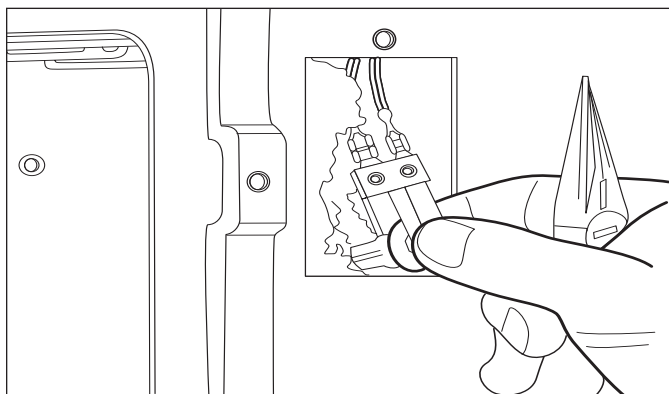

Figure 4-28. Probe Switch Removal.

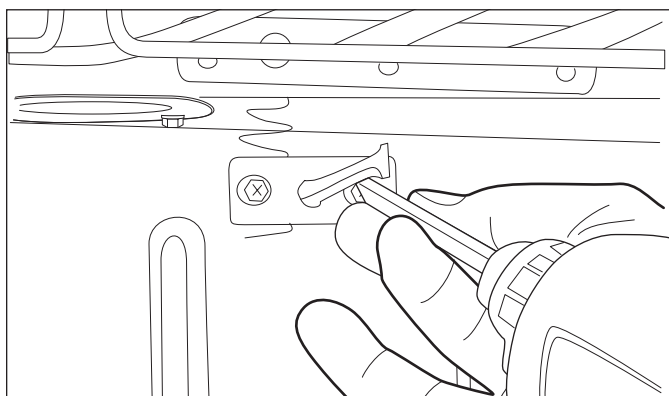
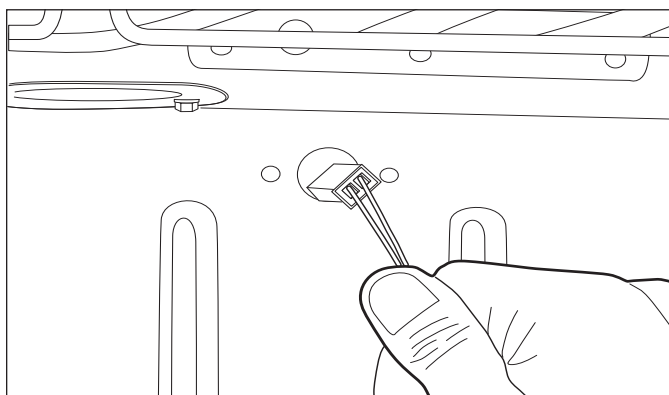
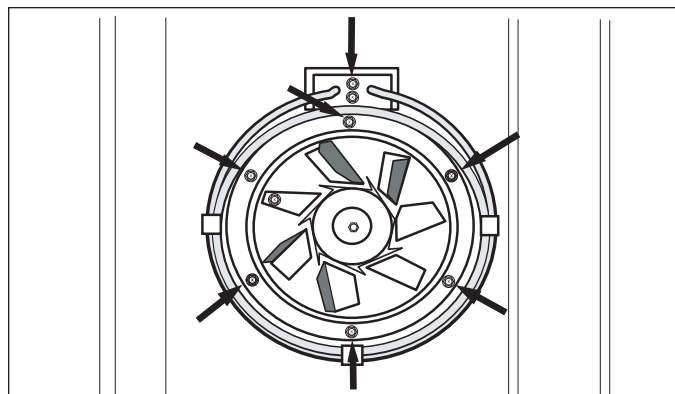

Figure 4-29. Temperature Sensor Removal.



Convection Fan Assembly Removal

The racks, rack guides and convection baffle plate will need to be removed first. Then, extract the seven screws around the convection fan and the top screw located between the element (where the element goes through the oven cavity). (See Figure 4-31). Now, pull fan assembly into oven cavity and disconnect wiring and remove.

**Figure 4-31. Convection Fan Removal.****Broil Element and Broil Pan Removal**

To have more room when removing the broil element, remove the racks from the unit. Next, extract the four screws that secure the element and broil pan to the ceiling of the oven cavity. (See Figure 4-32). Now, extract the two screws that secure the element leads through the oven cavity. Then, pull the element forward and down into the oven cavity until the terminals and wires are exposed. (See Figure 4-33). Now, disconnect the wires and remove the element and broil pan.

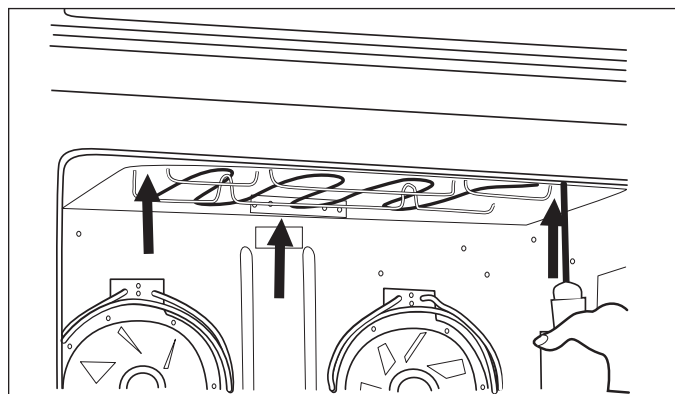
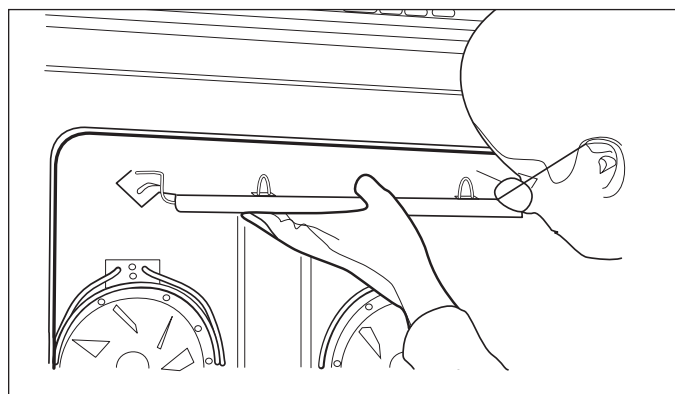
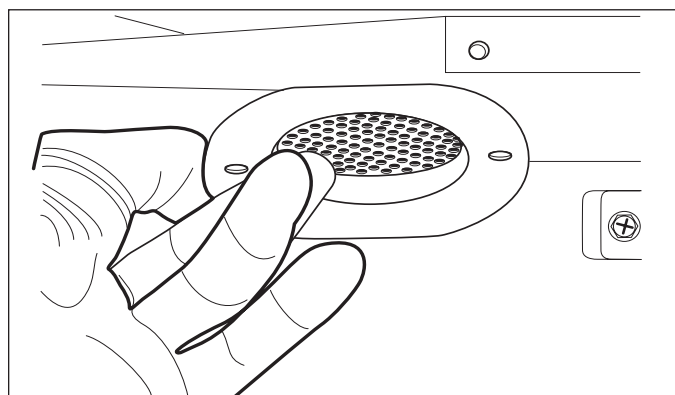
**Figure 4-32. Broil Element Removal.****Figure 4-33. Broil Element Removal.****Figure 4-34. Smoke Catalyst Removal.**

⚠ WARNING

IN ORDER TO REMOVE THE FOLLOWING COMPONENTS, THE ENTIRE OVEN WILL HAVE TO BE REMOVED FROM ITS INSTALLATION.

Bake Stone Receptacle Removal

First remove the ceramic receptacle plug from inside the oven cavity. Now, from the rear of the oven, extract the two nuts which secure the receptacle to the cavity and remove. (See Figure 4-35). The retainer plate can now be removed from the inside oven cavity.

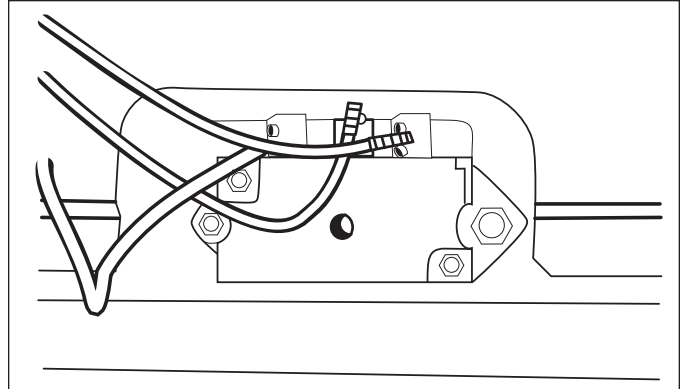

Figure 4-35. Bake Stone Receptacle Removal.

OVEN DOOR COMPONENTS:

Oven Door Removal

First, open the door to its fully opened position. Next, extract the screw and remove the plate from each side of the door hinges. Now, install the pin (*this pin is initially shipped with the unit and taped to the inside of the oven door*) through the hole in the left hinge arm. (See figure 4-36).

⚠ CAUTION

If the pin device is too long, it will rub against the inner door liner and chip the porcelain.

Lift the oven door to about a 60 degree angle from the horizontal. Now, pull the door away from the oven while continuing to lift and remove.

To reinstall oven door(s), grasp the oven door on opposite sides and lift the door until the hinges are aligned with the openings in the oven frame. Hold the door at about a 30 degree angle from the vertical. Slide the hinges into the openings until the bottom hinge arms drop fully into the hinge receptacles. Lower the door to the fully opened position and remove the pin from the left hinge arm. Open and close the door completely to ensure it is properly installed.

Door Adjustments

To adjust doors for height. Loosen the screws on the hinge pocket. Now, raise or lower the oven door to the desired height. Next, retighten the hinge pocket screws. Do this procedure for each side of the oven door until the desired height is obtained.

Door Gasket Removal

First, open the oven door. Now, locate the small clips attached to the underside of the gasket and gently pull the clips from the mounting holes. Next, pull the ends of the gasket out from the bottom of the door liner and remove. (See Figure 3-37).

NOTE: On units starting with serial #16000000 the gasket will be mounted to the front collar of the cavity. Removal procedure is the same. (See Figure 3-37A).

Outer Door Skin Assembly Removal

First, remove the oven door assembly and lay on front. Extract the two screws on the inside top of the door liner. Next, extract the three screws at the bottom of the outer door skin. Then, remove the outer door skin with handle and lay on front. Now, extract the four screws from the door handle assembly and remove. Remove the heat shield and insulation from the outer door skin. (See Figure 4-38).

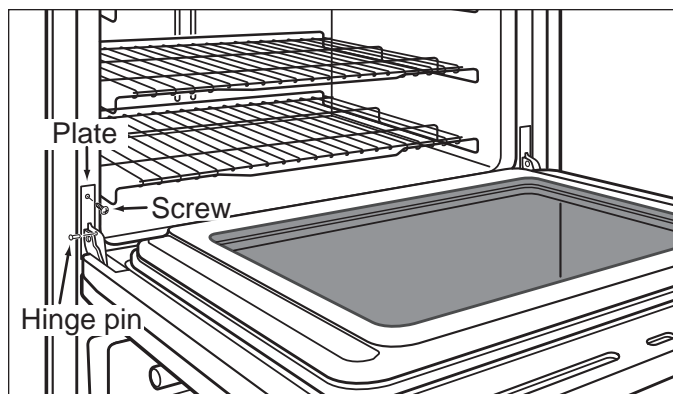

Figure 4-36. Hinge Pin Installation.

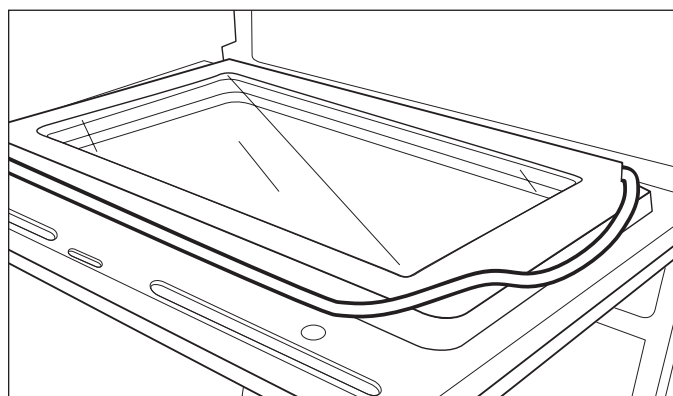

Figure 4-37. Door Gasket Removal.

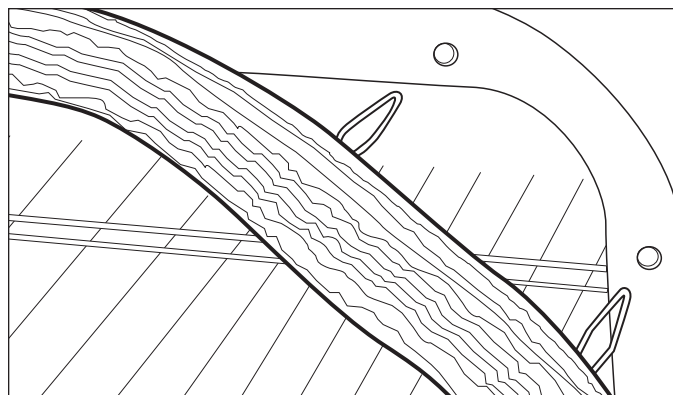

Figure 4-37A. Door Gasket Removal.

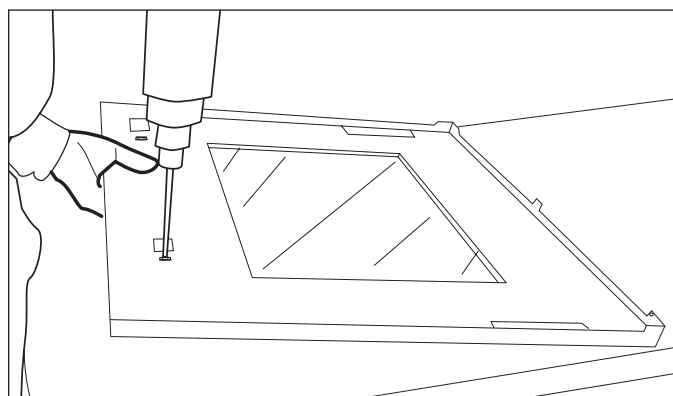

Figure 4-38. Outer Door Skin Removal.

Glass Pack Removal

NOTE: There are different screws sizes. Make sure the proper length screws are in the correct places when reassembling.

To begin, remove oven door assembly and outer door skin assembly. Now, extract the screw at the bottom center of the door liner. Next, extract the seven screws at the top of the heat shield and remove. (See Figure 4-39). Now, carefully remove insulation from around glass pack. Then, extract the screws from the top of the inner heat shield and remove. (See Figure 4-40). Now, lift the top of the glass pack up slightly while pulling it out from under the bottom tabs and remove. (See Figure 4-41).

⚠ CAUTION

When removing or disconnecting the door hinge, remember it could recoil quickly when released.

Hinge Removal

To begin, remove the oven door assembly and outer door skin assembly. Next, extract the two screws at the bottom corner of the door liner. (See Figure 4-42). Raise the bottom of the door hinge assembly from the door liner. Then, using a small flat bladed screwdriver, carefully raise the tab at the top of the hinge and slide the hinge out from under tab and remove. (See Figure 4-43).

Hydraulic Hinge Removal

To begin, remove the oven door assembly and outer door skin assembly. Next, extract the two screws at the bottom corner of the door liner. (See Figure 4-42). Now, raise the bottom of the hydraulic hinge assembly from the door liner. Then, using a small flat bladed screwdriver carefully raise the tab at the top of the hydraulic hinge and slide the hinge out from under tab and remove. (See Figure 4-43).

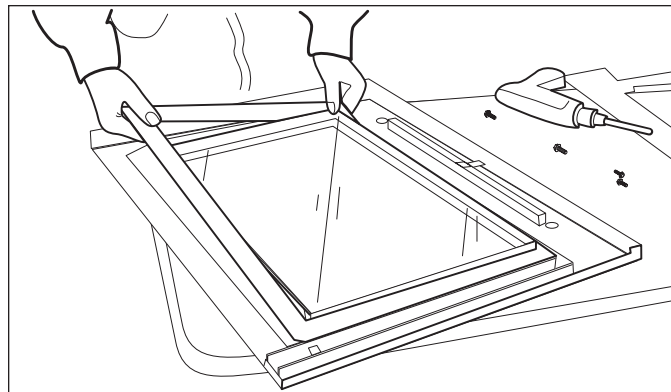

Figure 4-40. Removing Inner Heat Shield.

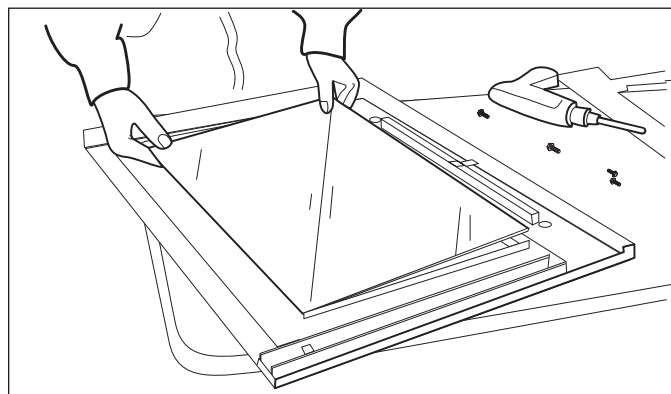

Figure 4-41. Removing Glass Pack Assembly.

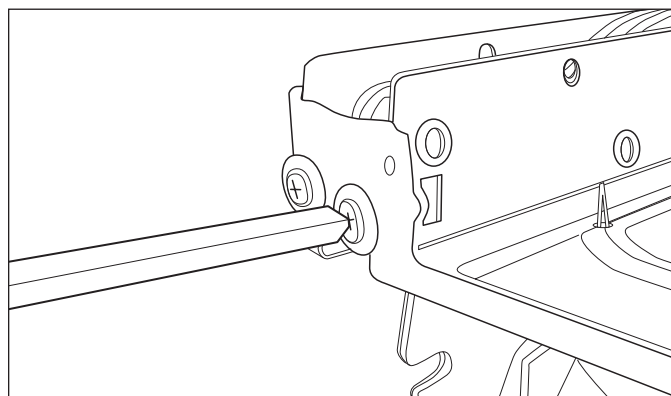

Figure 4-42. Extracting Screws for Hinge Removal.

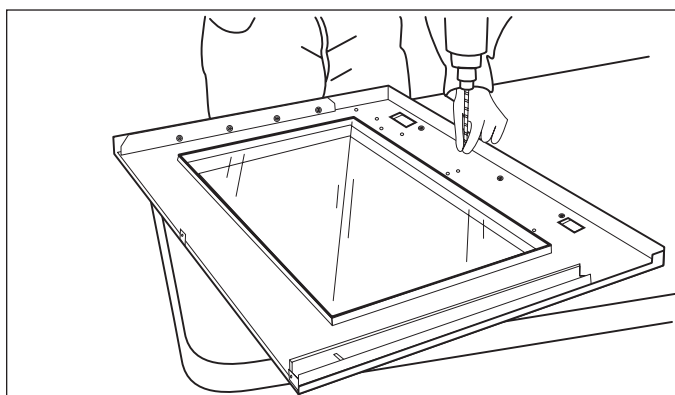

Figure 4-39. Extracting Screws from Heat Shield.

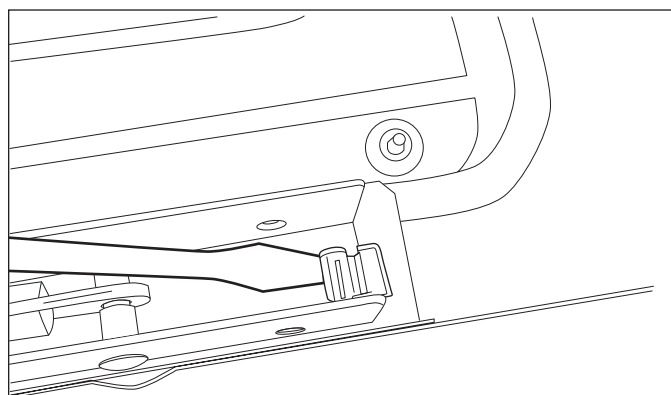

Figure 4-43. Raising Tab for Hinge Removal.

COMPONENTS BEHIND BACK PANEL:

⚠ WARNING

IT IS NECESSARY TO REMOVE THE UNIT FROM ITS INSTALLATION, REMEMBER THAT THE UNIT COULD TIP FORWARD WHEN PULLED BEYOND ITS INSTALLATION.

TO AVOID ELECTRIC SHOCK, POWER TO THE UNIT MUST BE DISCONNECTED WHENEVER SERVICING AND/OR ACCESSING COMPONENTS.

Back Panel Removal

Extract all the screws that secure the back panel to the unit and remove. (See Figure 4-44).

Divider Channels

Disconnect and remove any wiring which is routed through the channels. Now, extract the screws which secure the channels to the unit and remove. (See Figure 4-45).

NOTE: When disconnecting the wiring, make sure to mark the wire locations. This will ensure proper placement when reinstalling.

Lower Cooling Fan and Cover Removal

The back panel will need to be removed. Now, extract the screws from the left and right side off the cooling fan cover. Then, extract the screw from inside the fan cover which is secured to the divider channel and remove fan and cover together. (See Figure 4-46). To remove the cover, extract the screws which secure the cover to the fan and separate the fan from the cover.

Bake Element Removal

Remove the back panel. Now, disconnect the wiring which is routed through the divider channels and disconnect the bake element harness connector. Extract the screws from the bake pan assembly. Then, pull the bake element from the unit. (See Figure 4-47).

⚠ CAUTION

The insulation is around the hidden bake element is very fragile. Removal of the bake element should be done with great care.

NOTE: The wiring may have to be routed around the bake element to fully remove it from the unit.

NOTE: When disconnecting the wiring, make sure to mark the wire locations. This will ensure proper placement when reinstalling.

NOTE: It may also be necessary to cut some of the wire ties from the electrical wiring in order to gain more space for the bake element to be pulled out.

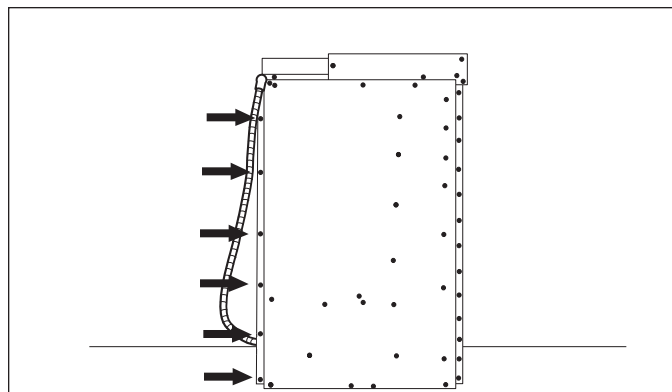

Figure 4-44. Back Panel Removal.

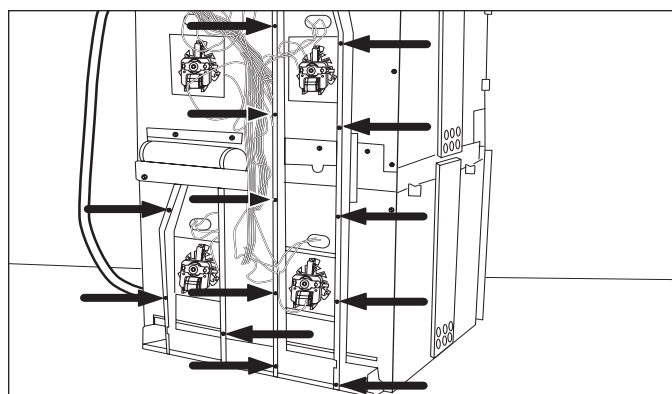

Figure 4-45. Divider Channel Removal.

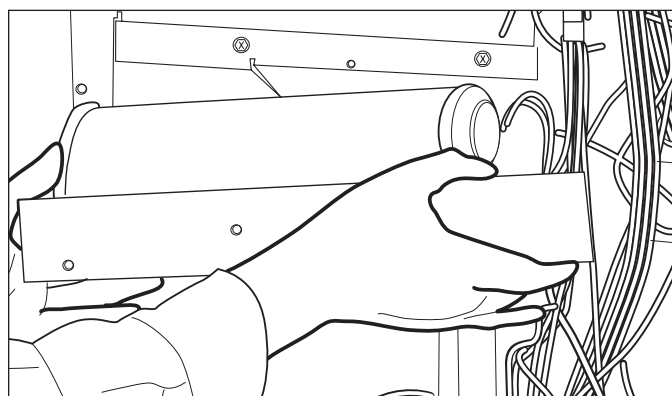

Figure 4-46. Lower Cooling Fan and Cover Removal.

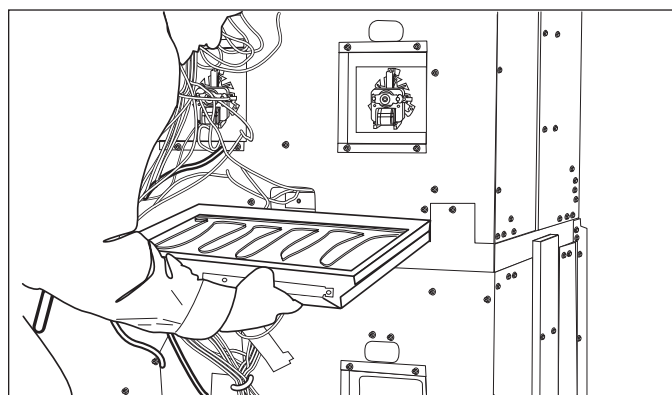

Figure 4-47. Hidden Bake Element Removal.

OVEN SIDE COMPONENTS:

⚠ WARNING

IT IS NECESSARY TO REMOVE THE UNIT FROM ITS INSTALLATION, REMEMBER THAT THE UNIT COULD TIP FORWARD WHEN PULLED BEYOND ITS INSTALLATION.

TO AVOID ELECTRIC SHOCK, POWER TO THE UNIT MUST BE DISCONNECTED WHENEVER SERVICING AND/OR ACCESSING COMPONENTS.

Channel Venting Removal

The channel is held in place by tabs at the rear and screws at the front. To remove, extract the screws around the channel. Now, lift the front of the channel out slightly while disengaging the tabs on the channel from the side enclosure. (See Figure 4-48).

Hinge Pocket Removal

The oven door will need to be removed first. Now, extract the screw from below the hinge slot at the front bottom of the oven cavity. Extract the screws around the hinge pocket and remove. (See Figure 4-49).

Enclosure Removal

First remove the channel venting and the hinge pocket. Now, extract the screws from the hold down brackets and remove. Then, extract the screws from around the enclosure. Next, slide the enclosure towards the rear, so that the front of the enclosure is out from behind the oven cavity. Now, pull the top of the enclosure out from under the pan module. Then, lift the enclosure from the side of the unit. (See Figure 4-50).

Insulation Removal

First, the channel venting, hinge pocket and enclosure need to be removed. Now the hinge cavity insulation, light insulation and cavity side insulation can be removed. (See Figure 4-51).

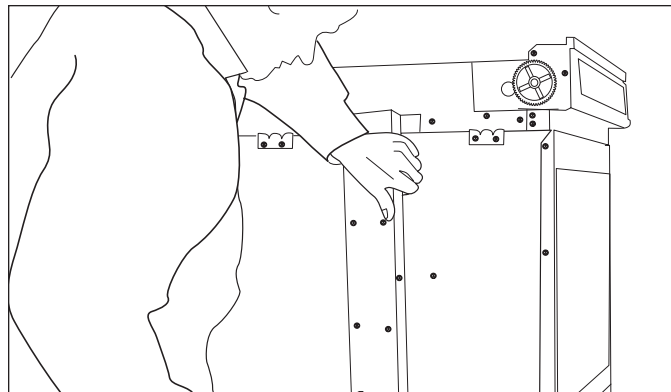

Figure 4-48. Channel Venting Removal.

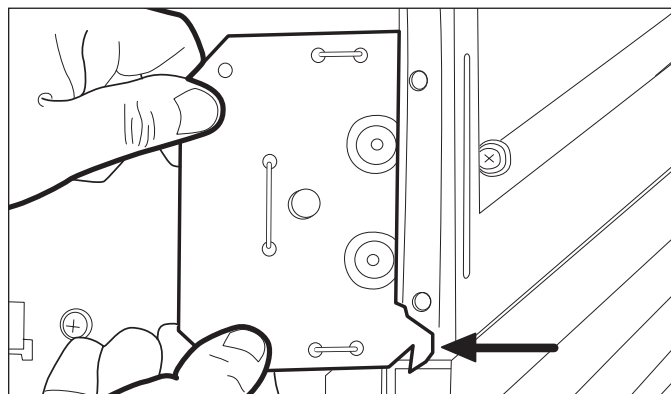

Figure 4-49. Hinge Pocket Removal.

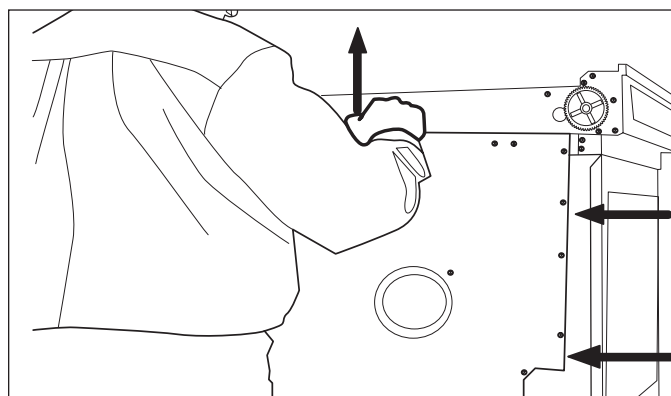

Figure 4-50. Enclosure Removal.

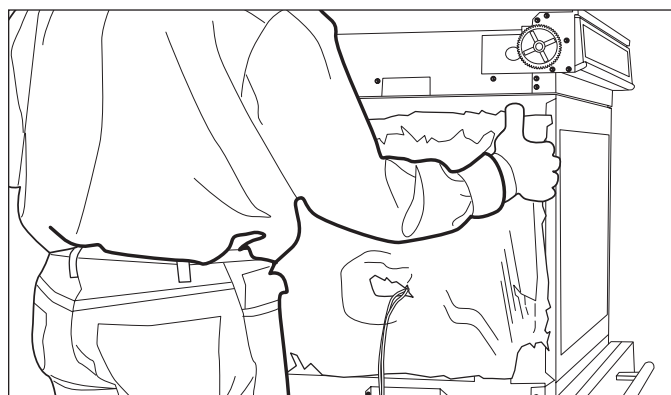

Figure 4-51. Insulation Removal.

SECTION 5

TROUBLESHOOTING GUIDE

TROUBLESHOOTING GUIDE

This section of the manual contains the General Troubleshooting Guide which will help the Service Technician troubleshoot a Wolf Wall Oven.

How to Use the Troubleshooting Guide

The troubleshooting guide table of contents shows how the troubleshooting guide is laid out. The troubleshooting guide is organized into component areas with the most common problems listed first.

On the table of contents below, identify the description of the problem that the unit is experiencing. To the left of the problem description is a letter. Locate that letter in the left column of the Troubleshooting Guide. The center column of the troubleshooting guide will identify the possible causes for the problem. The information to the right of the possible causes will explain what tests to perform in order to determine if what you are checking is the cause, and/or what action to take to correct the problem.

Troubleshooting Guide Table of Contents

	page #		page #
<u>Diagnostic Mode</u>		<u>Problems Associated with the Cooling Fan</u>	
Initiating Diagnostic Mode.....	5-3	I. Cooling Fan Does NOT Work.....	5-8
Possible Error Codes.....	5-4	J. Cooling Fan Noisy.....	5-8
Testing the Oven Relay Boards		<u>Problems Associated with the Convection Fan</u>	
Element Testing.....	5-5	K. Convection Fan Does NOT Work.....	5-8
Element Testing at the Relay Board.....	5-5	L. Noisy Convection Fan.....	5-8
Fans and Motors.....	5-6	M. Convection Fan Does NOT Shut Off	
RTD Testing.....	5-6	When Door Open.....	5-8
Probe Testing.....	5-6	<u>Problems Associated with the Oven Light</u>	
<u>Problems Associated with the Control Panel</u>		N. Oven Light Does NOT Work.....	5-8
A. Oven Display NOT Working.....	5-7	<u>Problems Associated with the Beeping</u>	
B. Unresponsive Key Pad.....	5-7	O. Random beeping.....	5-8
C. Control Panel Does NOT Rotate.....	5-7	P. Random beeping occurs when head	
<u>Problems Associated with Temperature</u>		is in the closed position.....	5-8
D. Long Preheat Time.....	5-7	<u>No Display Troubleshooting Flow Chart</u>	5-9
E. No Preheat.....	5-7	<u>Head Assembly Doesn't Rotate</u>	
F. Oven Temperatures Too High or Too Low.....	5-7	<u>Troubleshooting Flow Chart</u>	
G. Temperature Probe NOT Working.....	5-7		5-10
<u>Problems Associated with the Door Lock</u>			
H. Door Will NOT Lock In Self-Clean Mode.....	5-8		

INITIATING DIAGNOSTIC MODE

Diagnostic Mode allows the Service Technician to inspect the functionality of the Oven Controller and Relay boards. Entering a key combination on the oven touch pad will allow the Service Technician to enter Diagnostic Mode. In Diagnostic Mode the last seven errors that have occurred to the oven controlling all the relays on the relay board and controller feedback of temperature and switches will be displayed.

NOTE: The Double Oven stores a total of fourteen errors. Seven errors for the Upper Oven and seven errors for the Lower Oven.

NOTE: Diagnostic Mode will end two minutes after last key stroke or by pressing the CLEAR key.

Double Wall Oven Keyboard:

The Double Wall Oven controls consist of 1 double oven controller, 2 relay boards, 1 upper oven display, 1 lower oven display, 1 double wall oven keyboard, 1 stepper motor control board, 1 MRCP Drive Plate.

To initiate Diagnostic Mode for the Upper Oven, the oven must be OFF. Then press and hold upper TEMPERATURE key and the 0 "ZERO" key for 3 seconds, then release both keys. (See Figure 6-1).

NOTE: Diagnostic Mode will end 2 minutes after last key stroke or when the CLEAR key is pressed.

To initiate Diagnostic Mode for the Lower Oven, the oven must be OFF. Then press and hold lower TEMPERATURE key and the 0 "ZERO" key for 3 seconds, then release both keys. (See Figure 6-2).

NOTE: Diagnostic Mode will end 2 minutes after last key stroke or when the CLEAR key is pressed.

To initiate Diagnostic Mode for the Single Oven, the oven must be OFF. Then press and hold the TEMPERATURE key and the 0 "ZERO" key for 3 seconds, then release both keys. (See Figure 6-3).

NOTE: Diagnostic Mode will end 2 minutes after last key stroke or when the CLEAR key is pressed.

To toggle from one error code to another, the ENTER key must be pressed. The ENTER key will need to be pressed seven times to make sure there are no other codes.

To clear any error codes, the oven must be in diagnostic mode. Pressing the COOK TIME and STOP TIME key, at the same time will clear the error codes recorded. This must be performed after the unit is serviced.

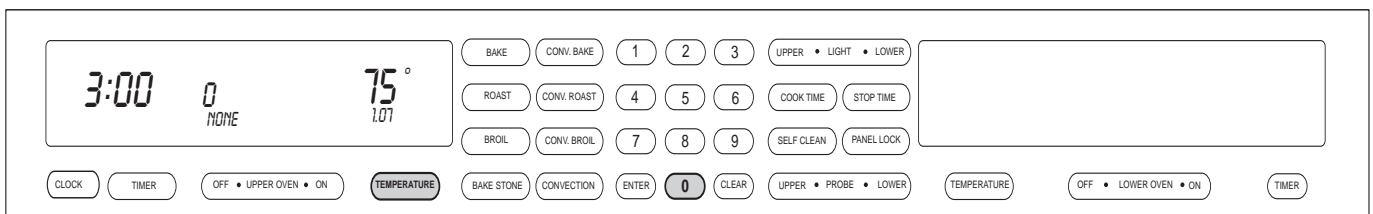

Figure 5-1. Initiate Diagnostic Mode Upper Oven - Press and hold the TEMPERATURE key and the "0" key.

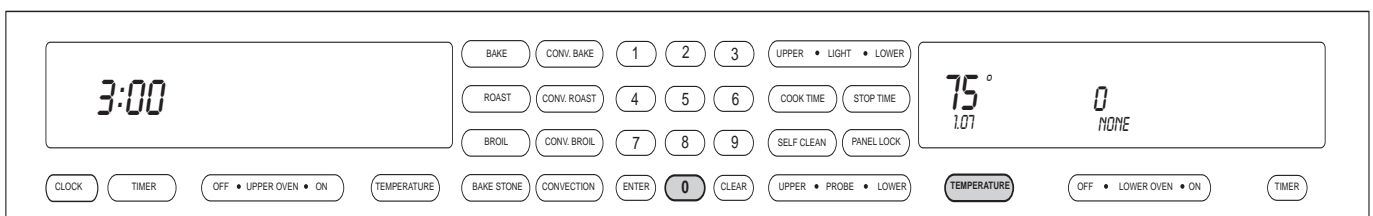

Figure 5-2. Initiate Diagnostic Mode Lower Oven - Press and hold the TEMPERATURE key and the "0" key.

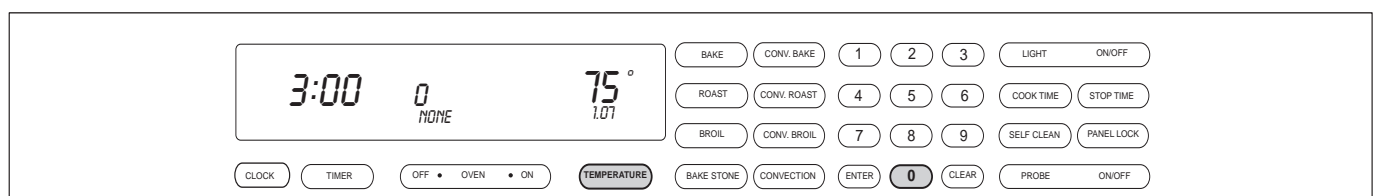

Figure 5-3. Initiate Diagnostic Mode Single Oven - Press and hold the TEMPERATURE key and the "0" key.

ERROR CODE CHART		
ERROR CODE	POSSIBLE CAUSE	TEST / ACTION
F1	Door Lock or Unlock Switches not sensed within 60 seconds while driving the door lock motor	Ohm door lock switches. Replace MDL (Motor Door Lock) Assembly
OVER TEMP	Over temperature occurs when the oven reaches a temperature of 630 °F for an unlocked door and 930°F for a locked door	Ohm RTD sensor, replace if bad. If RTD good replace Relay board.
RTD OPEN	Open circuit detected on RTD Oven Sensor	Replace RTD Sensor
RTD SHORTED	Shorted circuit detected on the RTD Sensor	Replace RTD Sensor
KEYBOARD ERROR	Key communication error	Replace Control Panel Assembly
KEY COMM	Failure between the Oven Controller and the Control Panel Assembly	Check flat flex cable between control panel assembly and oven controller for bad connection. Replace Oven Controller.
COMM ERR	Communication lost with the oven controller	Replace Control Panel Assembly
CHECKSUM	Self check done at power up, and when the oven off key is pressed.	Replace Oven Controller
PROBE SHORTED	Temperature probe failure	Re-seat probe Replace Temperature Probe
EEPROM	Cannot read or write to Eeprom	Replace Oven Controller
SENSOR CAL	Analog to Digital error during calibration phase	Replace Oven Controller
CONTROL COM	Communication lost with the oven controller	Check flat flex cable between control panel assembly and oven controller for bad connection. Replace Oven Controller.
RELAY CAL	Relay phase calibration failed the timing problem with the relay on the relay board	Replace relay board ONLY if the error is noted four consecutive times when in diagnostic mode
RELAY STUCK	Power relay shorted - sensed as being closed when it should be open by current sensor on the oven controller	Replace Relay Board
COOL FAN	Cooling fan failure	Ohm cooling fan, replace if defective.
SPI COMM	Communication lost with the oven control board	Check flex ribbon cable from head assembly to oven control board, unplug and replug. Troubleshoot using flow chart and end of Section 5
LOWER RELAY	Lower oven shift register feedback has indicated a failure	Perform troubleshooting using flow chart at end of Section 5
FUSES WRONG	Controller configuration settings incorrect or code protection is disabled.	“OFF” Clears error. If error will not clear, replace main controller.

TESTING THE OVEN RELAY BOARD

Element Testing

First access Diagnostic Mode. Once in Diagnostic Mode, the Technician can press a key to activate an element. The element relay and the double line breaker(dlb) will close to complete a 240/208 VAC circuit through a specific element. If the Oven Controller detects the current running through the closed circuit, OVEN ON will be illuminated on the corresponding display.

NOTE: Diagnostic Mode will end 2 minutes after last key stroke or when the CLEAR key is pressed.

Key Pressed	Relay(s) activated	Display Response
Bake	Inner Bake Element	Oven On Illuminated
Broil	Broil Element	Oven On Illuminated
Bake Stone	Bake Stone Element	Oven On Illuminated
Convection Bake	Outer Bake Element	Oven On Illuminated
Convection Broil	Right Convection Element	Oven On Illuminated
Convection	Left Convection Element	Oven On Illuminated

Figure 5-4. Element Testing Chart

Ohm Testing Elements at Relay Board

This procedure will allow the service technician to ohm any of the elements directly at the relay board.

At the relay board, pull the wire off of the terminal DLB/E11. This is done to keep from ohming the relay board. It does not take the High Limit out of the equation, but if the technician DOES NOT get an ohm reading from the DLB lead to all of the element leads, then, there is a problem with the High Limit.

To eliminate the High Limit when taking ohm readings, the MDL cover will need to be removed. Then, remove the wire from High Limit switch that goes to the elements. Now, take the ohm reading from that wire at the High Limit to the desired element wire at the relay board.

Right Convection Element: PR5/E5 to DLB/E11 wire

Left Convection Element: PR2/E5 to DLB/E11 wire

Outer Bake Element: PR4/E8 to DLB/E11 wire

Inner Bake Element: PR3/E6 to DLB/E11 wire

Bake Stone Element: PR6/E10 to DLB/E11 wire

Broil Element: PR1/E4 to DLB/E11 wire

Fans and Motors

First access Diagnostic Mode. Once in Diagnostic Mode, the technician can press a key to activate a fan or a motor. The fan and motor relays will close to complete a 120 VAC circuit through a specific fan or motor. If the Oven Controller detects the functionality through switches, an indicator will be illuminated on the corresponding display.

NOTE: *Diagnostic Mode will end 2 minutes after last key stroke or when the CLEAR key is pressed.*

Key Pressed	Relay(s) activated	Action	Display Response
Roast	Motor Door Lock (MDL)	MDL switch in open position	Degree Icon (°) Illuminated
		MDL in transition	Degree and Centigrade Icon Off
		MDL switch in closed position	Centigrade Icon (°C) Illuminated
Convection Roast	Oven Light	Light turns on	Not applicable
Self Clean	Cool Fan Low	Cool Fan Low	COOL FAN LO
0	Cool Fan High	Cool Fan High	COOL FAN HI
Key 7	Left Convection Fan	Left Convection Fan	L CONV ON
Key 9	Right Convection Fan	Right Convection Fan	R CONV ON
Panel Lock	Fan Apparency logging	Used on units prior to serial number 11100847 which used Apperency Switches.	“L” = Fan apparency switch Note: <i>No display means no fan apparency switches.</i>

Figure 5-5. Fans and Motors Testing Chart

RTD Testing

First access Diagnostic Mode. Once in Diagnostic Mode, the RTD temperature as read by the Oven Controller is shown in the corresponding display.

NOTE: *Diagnostic Mode will end 2 minutes after last key stroke or when the CLEAR key is pressed.*

Probe Testing

First access Diagnostic Mode. Once in Diagnostic Mode, the Probe temperature as read by the Oven Controller is shown in the Stop Cook digits in the corresponding display. If the Probe has not been inserted, “0” will be shown as the Probe temperature. If the Probe has not been completely inserted creating a short circuit of the Probe, “998” will be shown as the Probe temperature.

NOTE: *Diagnostic Mode will end 2 minutes after last key stroke or when the CLEAR key is pressed.*

PROBLEM	POSSIBLE CAUSE	TEST / ACTION
A. OVEN DISPLAY <u>NOT WORKING</u>	No power, circuit breaker tripped	Reset circuit breaker. May have to call an electrician
	Loose or defective wire connection(s)	Repair or replace wiring
	Defective relay board	Perform testing procedure located at end of section 5
	Defective control board	Perform testing procedure located at end of section 5
	Defective head assembly assembly	Perform testing procedure located at end of section 5
B. UNRESPONSIVE KEY PAD(S)	Key panel in locked mode	Press and hold lock key for three seconds to unlock
	Oven in sabbath mode	Press Off key to exit sabbath mode
	Loose connection to flat flex cable from control panel assembly to oven control board	Check cable connections. Unplug and reseal. Test key again, still not working replace head assembly
C. CONTROL PANEL <u>DOES NOT ROTATE</u>	In Self-Clean Mode or cooking mode	Control panel will not rotate when in cooking modes
	Actuator Switch defective	Check continuity of switch, replace if defective
	Jumper wire between oven control and stepper motor loose/defective	Check continuity of wire. Repair or replace jumper wire if defective
	Defective stepper motor	Perform testing procedure located at end of section 5
	Drive motor assembly defective	Replace drive motor assembly
D. LONG PREHEAT (In all modes except broil)	Defective hidden bake element (About 90° offset)	Check for error codes in diagnostic mode. Perform element testing procedure. Replace if defective
E. NO HEAT (In all modes)		Repair or replace wiring
	Loose or defective wire connection(s) Shorted or open element	Check for error codes in diagnostic mode. Perform element testing procedure. Replace if defective
	Defective relay board	Check for error codes in diagnostic mode. Perform testing procedure located at end of section 5
	Hi limit tripped or open	Check temperature reading of limit, should be 350°F. If not, replace limit with correct part. Reset
F. OVEN TEMPERATURE TOO HIGH OR TOO LOW		Refer to Use/Care Guide for operation
	Customer using wrong temperature User Preference Offset miscalibrated	Check UPO setting. Refer to instructions on page 3-3. Before making any temperature changes to UPO, check oven temperature with thermometer. UPO setting can be ±35°F.
	Defective RTD Sensor	Check ohms of RTD Sensor according to technical data. Replace if out of specification
G. TEMPERATURE PROBE NOT WORKING	Wrong cooking mode for probe	Refer to Use/Care Guide for operation
	Probe not inserted all the way into the receptacle	Check for error codes in diagnostic mode. Insert probe into receptacle first before initiating diagnostic mode

PROBLEM	POSSIBLE CAUSE	TEST / ACTION
H. DOOR WILL NOT LOCK IN SELF-CLEAN MODE	Loose or defective wiring	Check for error codes in diagnostic mode. Perform testing procedure. Repair or replace wiring
I. COOLING FAN DOES NOT WORK	Defective MDL (<i>Motor Door Lock</i>)	Ohm switches and motor. Replace if defective
	Loose or defective wiring	Repair or replace wiring
	No power to cooling fan	Check for power from J3 on relay board while using diagnostic mode to toggle between speeds. Low speed , J3 - Pin 3 to Neutral (E3) High speed , J3 - Pin 1 to Neutral (E3) 120VAC ± 10% should be present. If not, replace relay board.
J. COOLING FAN NOISY	Air diverter bracket loose	Tighten air diverter bracket screws or replace rivots
	Defective cooling fan motor	Check for error codes in diagnostic mode. Perform testing procedure. Ohm motor, replace if out of specifiatons according to technical data.
K. CONVECTION FAN DOES NOT WORK	Loose or defective wire connection	Repair or replace wiring
	Defective convection motor	Check for error codes in diagnostic mode. Perform testing procedure. Replace convection fan assembly
L. NOISY CONVECTION FAN	Fan blade out of balance	Replace convection motor assembly
	Loose fan blade	Tighten nut for fan blade
	Loose mounting	Tighten screws for mounting
M. CONVECTION FAN DOES NOT SHUT OFF WHEN OVEN DOOR OPEN	Defective door switch	Check continuity of door switch. Replace if defective
N. OVEN LIGHT DOES NOT WORK	Defective bulb (<i>if only one bulb out</i>)	Replace bulb
	Loose or defective wiring	Repair or replace wiring
	Defective fuse (<i>if both bulbs out</i>)	Replace fuse
	Defective door switch (<i>if both bulbs out</i>)	Check continuity of door switch. Replace if defective
	Defective key pad (<i>if both bulbs out</i>)	Replace control panel assembly
	Defective transformer (<i>if both bulbs out</i>)	Replace transformer
	Defective relay board	Replace relay board
O. RANDOM BEEPING	Noisy Input Power	Check grounding wire. Install if missing
	Display Case Plastic Bushing	If plastic bushing is there, remove it
	Low Input Power	Replace relay board.
P. RANDOM BEEPING OCCURS WHEN HEAD IS IN THE CLOSED POSITION	Bad VFD	Replace the head assembly.
	Change of the Pal chip on the display board.	Replace the head assembly.

Troubleshooting Flow Chart

Step 1. Check Wire Connections (Disconnect power to unit)

Check wire connections J4 and J5 on oven controller to J1 connector of relay board. Unplug both ends and reseal.

Check flex ribbon cable at J11A connector on oven controller, unplug at oven controller and reseal.

Check wire connections at E1 (L1) and E2 (N) connector on relay board, unplug both ends and reseal.

Unplug ribbon cable, check for broken or bent pins. If no broken or bent pins, reconnect ribbon cable.

⚠ WARNING

DISCONNECT POWER TO UNIT BEFORE UNPLUGGING WIRE(S) AND CONNECTIONS

WHEN PERFORMING CONTINUITY CHECKS, POWER TO THE UNIT MUST BE DISCONNECTED

Step 2. Testing Voltage to Relay Board (Power reconnected to unit)

Check for voltage at E1 (L1) to E2 (N) on relay board. Do you have 120 VAC ± 10%?

Check for voltage at L1 and N on terminal Block. Do you have 120 VAC ± 10%?

Check for loose or defective wiring to unit from terminal block to junction box/power cord. May have to call an electrician.

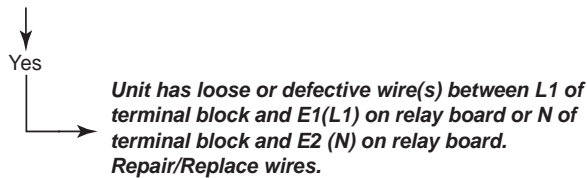
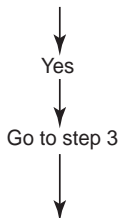

Step 3. Testing Communications

NOTE: Following checks are performed with cables connected unless otherwise noted.

Do you have 36 to 41 VDC Pins 14 & 17 at J4 or J5 (Controller)? (See Figure 1)

Do you have 36 to 41 VDC Pins 14 & 17 at J1 (Relay Board)? (See Figure 2)

Do you have 36 to 41 VDC at J11A (See Figure 2) from Pin 1 to pin 2?

Yes
↓
Do you have 8 to 11 VAC from pins 8 & 9 at J11A (See Figure 2)?

No → Do you have 4 to 8 VAC between pins 8 & 9 at J11A (See Figure 2)?

No → **Replace Relay Board**

Yes
↓
Go to Step 4

Yes
↓
Replace Comm Cables

No → **Replace Control Head Assy.**

Step 4. Testing Oven Controller

Using a volt/ohm meter set to read DC voltage, at J2 Connector of the stepper motor control board, place one meter probe to pin 1 and one meter probe to pin 2.

With harness connected and unit turned "OFF", do you have 1 to 3 VDC at J2 from pin 1 to pin 2?

No → **Replace oven controller.**

Yes
↓
With harness disconnected and unit turned "OFF", do you have 4 to 6 VDC between pin 1 & pin 2 of harness?

No → **Replace oven controller.**

Yes
↓
Replace Control Head assembly

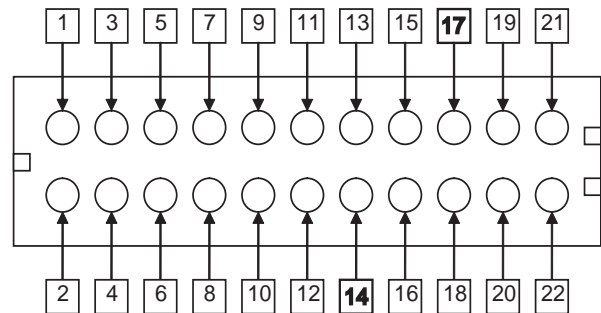

Figure 1. J4 and J5 Configuration

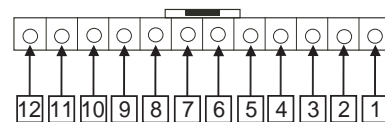

Figure 2. J11a Configuration

Head Assembly Doesn't Rotate Troubleshooting Flow Chart

⚠ WARNING

WHEN PERFORMING CONTINUITY CHECKS, POWER TO THE UNIT MUST BE DISCONNECTED

Using a volt/ohm meter set to read AC voltage, at connector J1 on the Stepper Motor Control Board, place one meter probe to pin 1 and one meter probe to pin 3.

Do you have 120 VAC ± 10% from pin1 to pin 3? → No → Do you have 120 VAC ± 10% from L1 to N? → No → Check for loose or defective wiring to unit from terminal block to junction box/power cord. May have to call an electrician

Yes

Yes

Unit has loose or defective wire(s) between L1 and N of terminal block to J1 connector on stepper motor control board. Repair/Replace wires.

Using a volt/ohm meter set to read ohms. Unplug the J5 connector at stepper motor control board. Check continuity of the switch, with your ohm meter, while depressing the switch.

Do you have continuity of switch? → No → **Replace defective actuator switch**

Yes

Using a volt/ohm meter set to read DC voltage, at the J2 connector of the stepper motor control board, place one meter probe to pin 1 and one meter probe to pin 2.

With the wires connected, do you have 2 VDC from pin 1 and pin 2 ? → No → **Replace oven controller**

Yes

With the wires disconnected, do you have 5 VDC from pin 1 and pin 2 ? → No → **Replace oven controller**

Yes

At the J4 connector of the stepper motor control board, check from pin 6 to any of the first four pins, while depressing the switch. 11 VDC present while cycling.

No

Replace the stepper motor.

SECTION 6

TECHNICAL DATA

Technical Data Chart					
Part Description	Part Number	Voltage	Amperage	Watts	Ohms
Motorized Latch	800263	120		4	2900
Temperature Sensor	800306				1091 @ 75°F
Oven Light	800307	12		20	.6
Element, Convection	800341	240	9.09 to 10.52	2182 to 2526	22.80 to 26.39
Element, Convection		208	7.87 to 9.12	1638 to 1897	22.80 to 26.39
Fan, Convection CCW	800345	120		55	8.8
Fan, Convection CW	800350	120		55	8.8
Element, Bake Outer	800360	240	6.55 to 7.23	1572 to 1737	33.16 to 36.64
Element, Bake Inner		240	7.34 to 8.11	1762 to 1947	29.58 to 32.69
Element, Bake Outer		208	5.67 to 6.27	1180.75 to 1304.68	33.16 to 36.64
Element, Bake Inner		208	6.36 to 7.03	1323.46 to 1462.41	29.58 to 32.69
Upper Cooling Fan	801143	120		65	HI 9.7 / LO 12.8
Lower Cooling Fan	800529	120		80	HI 7.8 / LO 10.0
Temperature Probe	800717				34,000 @ 90°F
Element, Bake Stone	800950	240	13.22 to 15.30	3174 to 3673	15.68 to 17.14
Element, Bake Stone		208	11.46 to 13.26	2384.03 to 2758.83	15.68 to 18.14
Transformer		120 to 12		3600	16
Element, Broil 30"	801120	240	13.63 to 15.79	3273 to 3790	15.19 to 17.59
Element, Broil 30"		208	11.81 to 13.68	2458.39 to 2846.71	15.19 to 17.59
Element, Broil 36"		240	15.15 to 17.54	3636 to 4211	15.84 to 13.67
Element, Broil 36"		208	13.13 to 15.20	2731.04 to 3162.93	13.67 to 15.84

Ohm Testing Elements at Relay Board

This procedure will allow the service technician to ohm any of the elements directly at the relay board.

At the relay board, pull the wire off of the terminal DLB/E11. This is done to keep from ohming the relay board. It does not take the High Limit out of the equation, but if the technician DOES NOT get an ohm reading from the DLB lead to all of the element leads, then, there is a problem with the High Limit.

To eliminate the High Limit when taking ohm readings, the MDL cover will need to be removed. Then, remove the wire from High Limit switch that goes to the elements. Now, take the ohm reading from that wire at the High Limit to the desired element wire at the relay board.

- Right Convection Element:** PR5/E5 to DLB/E11 wire
- Left Convection Element:** PR2/E5 to DLB/E11 wire
- Outer Bake Element:** PR4/E8 to DLB/E11 wire
- Inner Bake Element:** PR3/E6 to DLB/E11 wire
- Bake Stone Element:** PR6/E10 to DLB/E11 wire
- Broil Element:** PR1/E4 to DLB/E11 wire

Operation Time Chart			
Mode	Element(s)	Operation Time (Approx.)	Convection Fan Approx. ^(App)
Bake	Hidden Bake Broil	80% 10%	
Convection*	Convection (2)	100% Sequential	100% Sequential
Convection Bake*	Hidden Bake Convection (2)	10% 90% Sequential	100% Sequential
Broil	Broil	100%	
Convection Broil	Broil	100%	100%
Roast*	Hidden Bake Broil	75% 25%	
Convection Roast*	Convection (2) Broil	48% 17%	100%
Bake Stone*	Bake Stone Broil	58% 42%	42% Sequential

* Pre Heat Required

Operation Time Chart			
Mode	Elements	Operation Time	Duration
Self Clean	Stage 1		12 minutes
	Hidden Bake	0 - 12 seconds	
	Broil	12 - 60 seconds	
	Stage 2		Until Oven Reaches 850°F
Hidden Bake	0 - 12 seconds		
	Broil	12 - 60 seconds	

NOTE: Door locks at start. Unlocks at 300°F.

Cooling Fan Operational Temperatures	
Lo Speed - ON @ 180°F	Lo Speed - OFF @ 140°F
High Speed - ON @ 430°F	High Speed - OFF @ 380°F

NOTE: With unit "OFF" fan will turn "OFF" at 300°F.

Preheat Times				
Mode	Temp.	240V DO30/SO30	208V DO30/SO30	NOTE: Preheat times are approximate.
Bake	350 °F	13 min.	16 min.	
Convection Bake	375 °F	15 min.	19 min.	
Convection Roast	325 °F	13 ½ min.	16 min.	
Convection	325 °F	13 min.	18 min.	
Roast	350 °F	11 min.	14 1/2 min.	
Bake Stone	400 °F	24 min.	36 min.	

Temperatures higher than 375°F need longer preheat time. 400°F can take about 20 minutes.

SECTIO

N 7

WIRING

DIAGRAMS

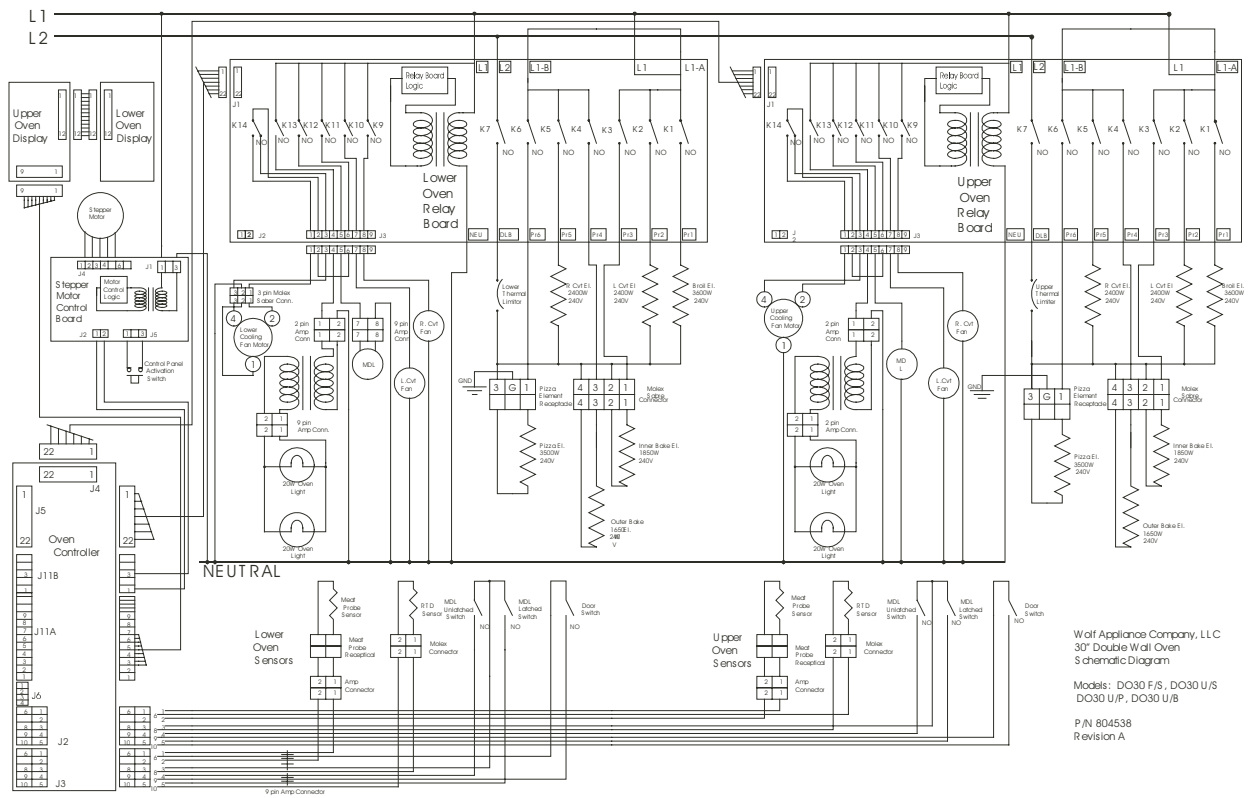

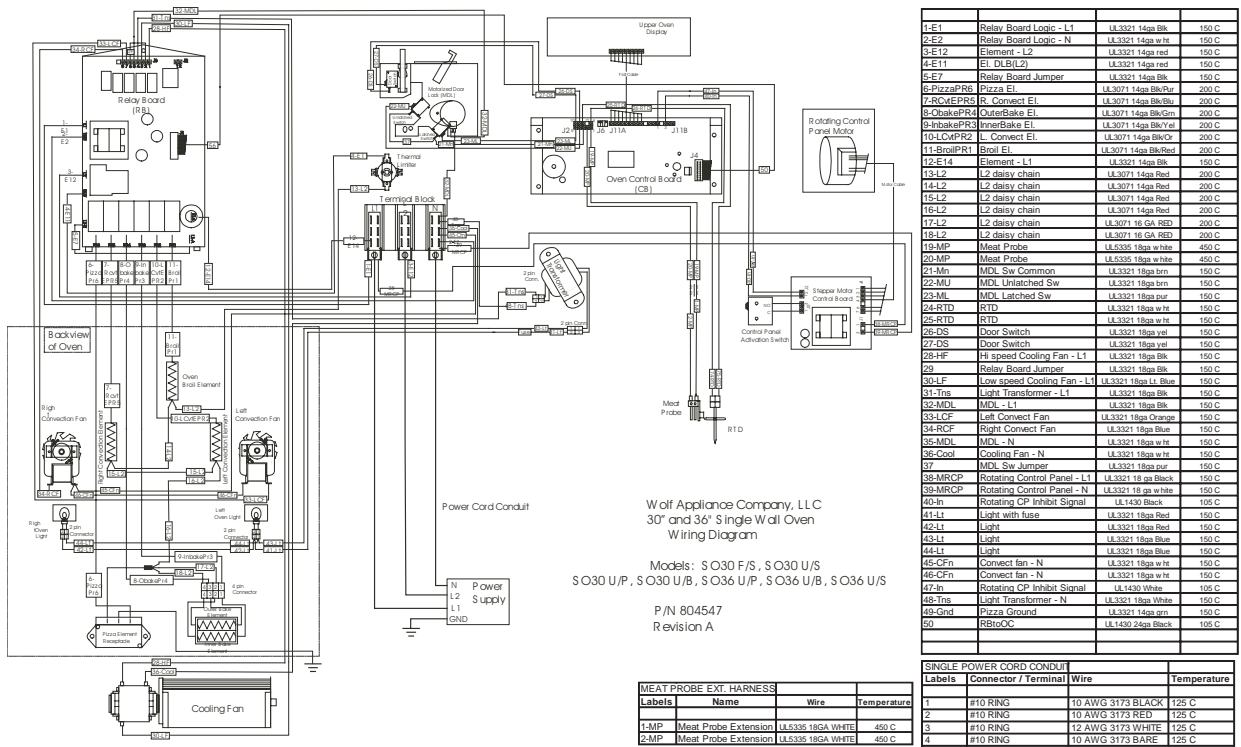

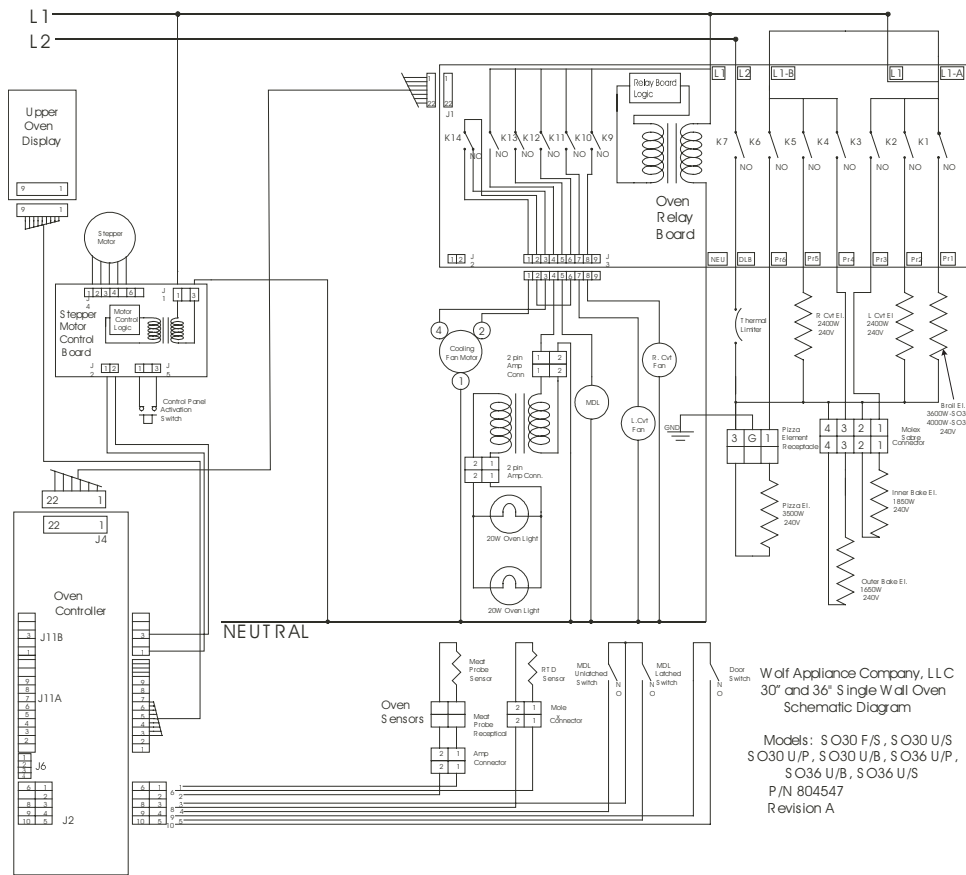

Wolf Appliance Company, LLC
 30" and 36" Single Wall Oven
 Schematic Diagram
 Models: S O30 F/S, S O30 U/S
 S O30 U/P, S O30 U/B, S O36 U/P,
 S O36 U/B, S O36 U/S
 P/N 804547
 Revision A

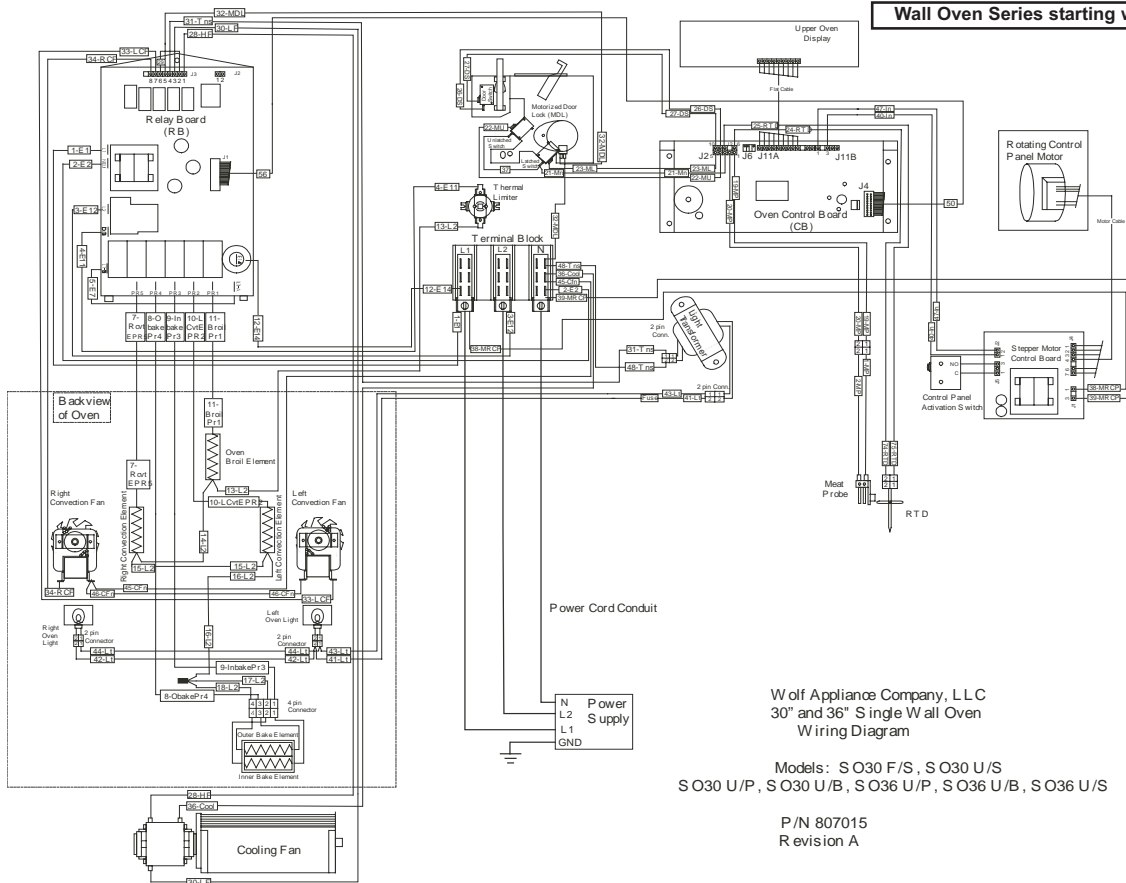

Wall Oven Series starting with Serial #1600000

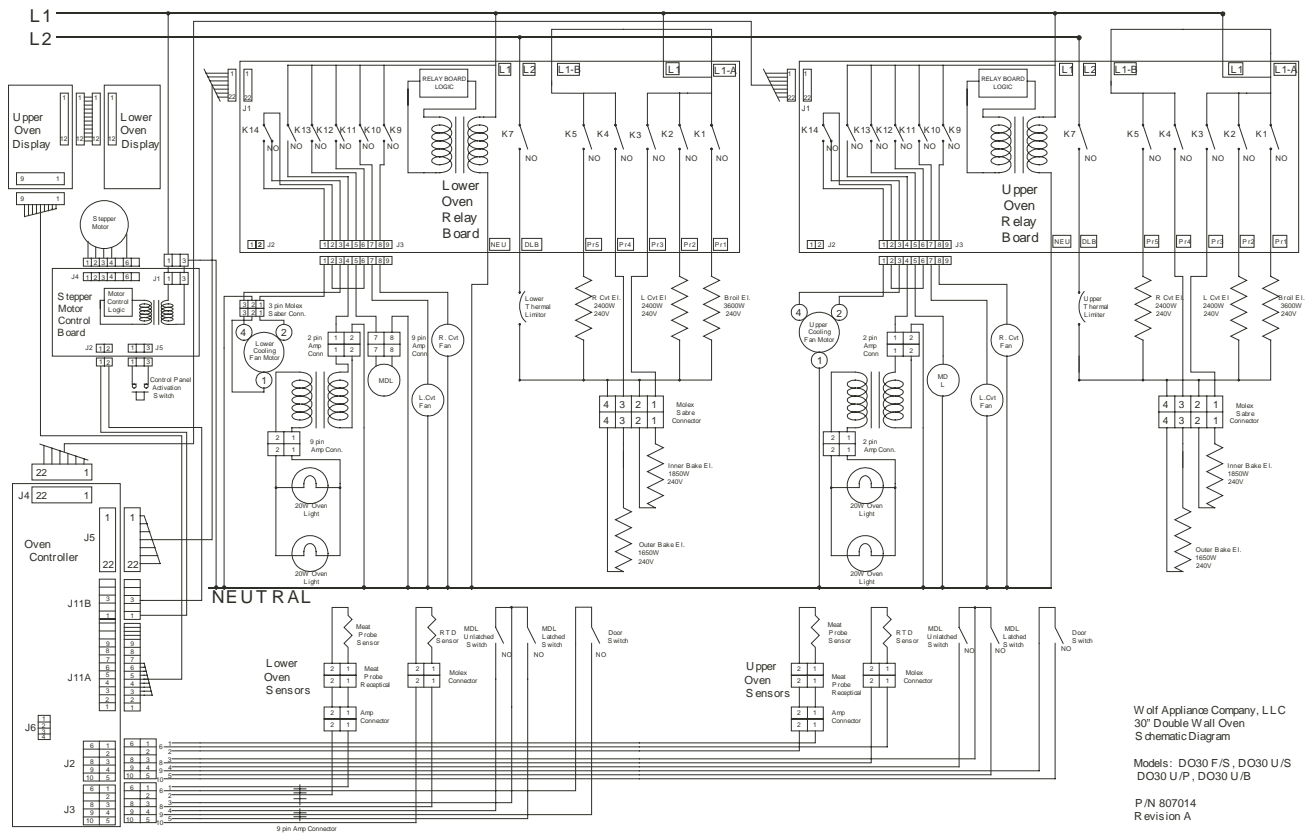

Wolf Appliances Company, LLC
 30" Double Wall Oven
 Schematic Diagram
 Models: DO30 F/S, DO30 U/S
 DO30 U/P, DO30 U/B
 P/N 807014
 Revision A