



A MULTI-USE EVAPORATIVE AIR COOLING MACHINE



# OWNER'S GUIDE

## USE AND CARE MANUAL

### MODEL CTV2

For Customer Assistance

CALL 1-800-325-6952

DO NOT RETURN TO PLACE OF PURCHASE!

- |                |                     |
|----------------|---------------------|
| * Safety       | * Maintenance       |
| * Installation | * Trouble Shooting  |
| * Operation    | * Parts Replacement |

**READ AND SAVE THESE IMPORTANT SAFETY INSTRUCTIONS**

- Read all instructions carefully before installation.
- This cooler must be connected to 120 volt AC, 60 Hz (cycle) power only. NOTE: Improper voltage will void the pump and/or motor warranties and may cause serious personal injury or property damage.
- This cooler must be plugged into a GFCI protected receptacle, which has been properly installed in accordance with all local and national codes. If you are not sure that the receptacle is GFCI protected, consult with a qualified electrician.
- This cooler is equipped with a power cord having an equipment grounding conductor and grounding plug. Do not attempt to defeat this safety device by removing the grounding pin.
- Do not step on or rollover power cord with heavy or sharp objects. Do not operate if plug or cord is damaged in any way. If the unit is damaged or malfunctions, do not continue to operate it.
- Remove the plug from the electrical receptacle by pulling on the plug and not the cord.
- Always disconnect electrical power to unit before attempting to work on or service your cooler.
- Do not operate near open containers of flammable liquids or gases.

**Congratulations:** You have purchased a product of superior performance and design, which will give the best service when properly operated and maintained. This cooler can be used as a convenient, roll-around spot cooler or permanently installed through a wall for cooling fixed areas like a workshop or garage.

This guide was designed to provide you with the information needed to assemble the unit for roll-around spot-cooling use or to permanently install the unit for fixed area cooling. It also contains information on how to safely operate, inspect, maintain and troubleshoot your CoolTool evaporative air cooler.

The first section, Assembly, contains instructions to prepare your cooler for roll-around portable service. The second section, Installation, guides you through the permanent installation process. The third section, Maintenance, contains operational and maintenance instructions to aid in keeping your unit in good working order, while Troubleshooting includes information to help diagnose and repair commonly encountered problems.

# READ THIS FIRST!

**WARNING - TO REDUCE THE RISK OF FIRE, ELECTRIC SHOCK, OR INJURY TO PERSONS, OBSERVE THE FOLLOWING**

- Do not operate this cooler (fan motor) with any solid-state speed control device.
- Do not operate this unit with pad frame(s) and/or air outlet grille removed, this may cause the fan motor to overload and damage the motor.
- Never wash your cooler cabinet with a garden hose, water may harm motor and pump.

**NOTE:**

- Do not use indoors on carpet or wood floor. Unit may leak water and could damage flooring or create a slip hazard.
- Do not locate or operate cooler near exhaust or vent pipes as odors or fumes may be drawn into unit.
- Your warranty does not cover shipping damage. Report all shipping damage at once to store making the delivery.
- For future reference, record the serial number and purchase date of your evaporative cooler here:

Serial # \_\_\_\_\_

Purchase Date: \_\_\_\_\_

Place of Purchase: \_\_\_\_\_

**THE USE OF ANODE DEVICES, CHEMICAL ADDITIVES, OR COOLER CLEANER TREATMENTS IN THIS COOLER WILL VOID THE WARRANTY.**

## Table of Contents:

Introduction	2	Location and placement	3	General inspection	5	Draining and touch-up	6
Unpacking	2	Exhaust openings	3	Pre-start-up	5	Lubrication	6
<b>Roll-around Assembly</b>		Support legs	3	Start-up checklist	5	Changing cooler pads	7
Roll-around casters	2	Duct extension	3	Cabinet inspection	5	<b>Troubleshooting</b>	8
Standpipe installation	2	Electrical requirements	4	Shutdown (winterizing)	5	<b>Parts list</b>	9
Water line connections	2	Standpipe installation	4	<b>Operating instructions</b>	5	<b>Warranty</b>	10
<b>Permanent Installation</b>		Water line connections	4	<b>Maintenance</b>			
Mounting requirements	3	Bleed-off installation	4	Cleaning	5		

## INTRODUCTION

Your CoolTool evaporative air cooler was thoroughly tested and inspected before leaving the factory. This is your guide to economical, trouble free comfort cooling over the years with reasonable care and regular maintenance. Failure to follow these instructions may damage your cooler, impair its operation and/or void the warranty. **Read it carefully.**

## PREPARATION FOR ASSEMBLY

### Unpacking the unit

The items required to use the CoolTool as a roll-around cooler or to convert it to a permanently installed cooler are packaged with this unit. Remove the pad frames by slightly lifting the pad frame from the bottom, pull outwards until clear of cabinet bottom pan, then downwards until frame clears cabinet top. Remove the following items from the cooler:

1. Box containing swivel casters and attachment hardware (for roll around use)
2. Duct extension (for permanent thru-wall installations)
3. Plastic bag containing small parts, float valve, standpipe and drain bushing. (used in both cooler model options)
4. Bag with hose adapter for float valve (roll-around use)
5. Bleed-off tubing (for permanent installations)

### Gather tools required to assemble & install unit

The following tools are required to assemble the unit:

- |                              |                    |
|------------------------------|--------------------|
| 7/16" box or open end wrench | 6" crescent wrench |
| 3/8" box or open end wrench  | 1/4" nut driver    |

Additional small hand and/or small power tools will be required to permanently install this unit, they will be determined by the individual requirements of the installation site.

## SETUP FOR ROLL-AROUND USE

### Attach swivel casters to legs

1. Locate unit on level working surface.
2. Note position of hardware attaching stand angles to cooler corners. Detach stand angles and save this hardware for re-assembly later.
3. Open parts box and remove casters and parts bag. Assemble (1) each caster per stand angle using supplied 1/4-20 nuts & carriage bolts as shown in figure 1.
4. Re-attach stand angles/caster assemblies to cooler corners, place the casters with brakes on the front of the unit. Use the 1/4-20 nuts & bolts saved in step 2 and additional 1/4-20 nuts and bolts from the parts bag on each corner (3 each angle/corner, see Fig 1). Apply brakes before lifting cooler upright to complete assembly.

### Install drain bushing and standpipe

Install overflow drain bushing in bottom of cooler. Slide rubber washer over drain bushing, push drain bushing through bottom of cooler, and tighten nut. Screw plastic overflow standpipe into the drain bushing and tighten snugly (hand-tight) to prevent leakage. Where conditions allow for drainage, connect a drain line (garden hose) to drain bushing and drain in accordance with local codes (see Fig 2)



Fig.2

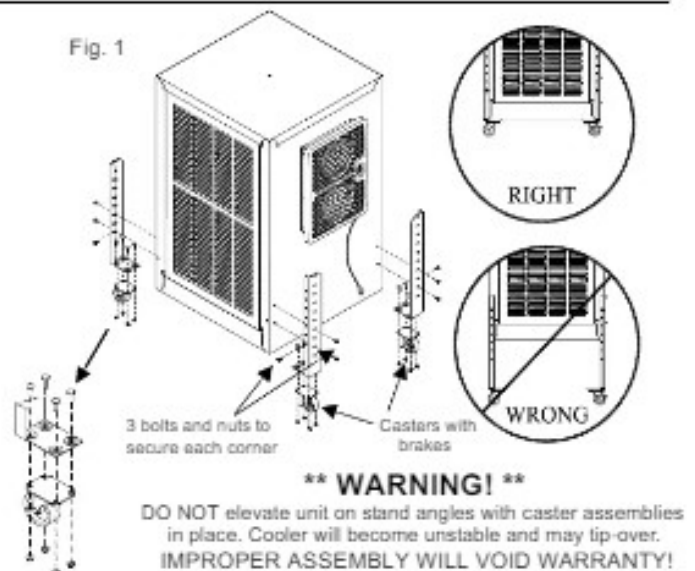

### Install float valve and hose adapter

Attach the float valve to the cabinet as shown in figure 3. Garden hose adapter attaches to the brass inlet fitting on the float valve (see figure 3). NOTE: verify that the hose washers are correctly in place.

### Water connection and float adjustment

Move cooler to desired location (this should be a level area for proper operation of the cooler).

1. Connect to water supply using a commercial grade of water hose (not supplied with cooler, obtained separately) to the adapter on the float valve and turn water on. CAUTION: water inlet pressure should be limited to a maximum of 65 PSI to avoid rupturing the water hose. If pressure exceeds this value, an inline pressure regulator should be installed (obtainable from a local plumbing or hardware store).
2. Check that all connections are tight by visually inspecting hose, float valve, etc. for leakage.
3. Set float valve for a water depth of 2". The float is adjusted lightly bending the float rod.

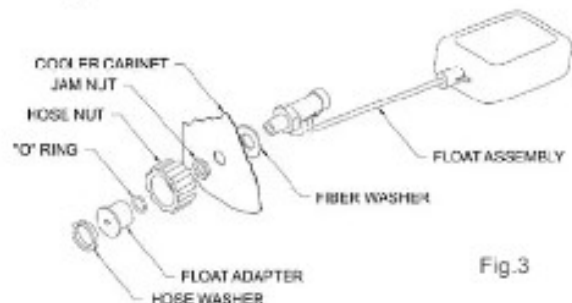

Fig.3

### Cooler checkout and first time start-up

Congratulations, once you re-install the pad frames, your roll-around CoolTool cooler will be complete and ready for use. Please proceed to the Pre-startup inspection checklist on page 6 starting unit for the first time.

## PERMANENT COOLER INSTALLATION

### Before you begin:

#### Carefully read before beginning the installation process.

Don't attempt to perform any part of the installation described in this manual unless you are **fully qualified** to do so.

#### Before attempting to install the cooler, make sure the following preparations have been made:

- Assure that the supporting surface is strong enough to bear the weight of the cooler when in use; remember that when the system fills with water, the cooler will be much heavier than when dry. This unit will weigh approximately **225 lbs** when full. It is recommended that the unit be supported on a 36" square concrete pad, 2" to 3" thick.
- Make sure the mounting surface is level in all directions; this is necessary to ensure proper distribution of water into the troughs of the pad frames and maximize performance.
- Locate the support pad so that the duct extension will be located between wall studs. The interior duct and grille assembly must be located within 6 ft of a GFCI protected 115-volt AC receptacle.
- It will be necessary to cut a hole through the wall large enough to allow the duct extension to pass through. Best method of marking the duct location is to first assemble the legs and the duct extension onto the cabinet (see the leg and duct extension attachment instructions). After locating the unit on the supporting pad, slide the cooler against wall and mark hole location.

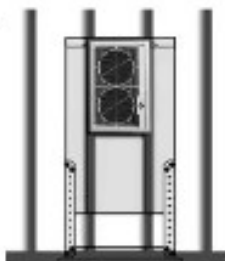

### Location

Install cooler so only fresh outside air enters cooling system. Avoid installing unit in an area that would restrict free air movement around the cooler. Avoid installation near vents, kitchen exhaust, etc.; odors or fumes may be drawn into unit.

### Air Exhausting

Evaporative air coolers will function correctly only if there is a way for the cooled air to exit the room. Your CoolTool will function best when there are plenty of openings for air to leave the cooled space. Proper location of exhaust openings is important as they guide the flow of air through areas where cooling is desired. Windows or doors farthest away from cooler grille should be left open to permit free movement of air out of the area being cooled.

To obtain the maximum capacity of your cooler, open windows, doors, etc until the air inside the house is nearly balanced with the outside. One method to determine when the air is reasonably balanced is to place a tissue paper against the screen in a window furthest from the cooler and adjust the openings of the other windows or vents until the tissue paper stays lightly on the screen.

### Installation Procedure

The "Cool" and "Fan" switches on the front grille must be in the **OFF** position and the power cord **UNPLUGGED** from the receptacle before attempting to install this unit. To prevent accidental starting of the cooler, ensure that the cord cannot be plugged in until installation has been completed.

### Adjust legs to support cooler

The support legs are assembled to the unit in the shipping position. The 1/4-20 nut and bolt combinations securing the legs must be removed, the legs adjusted to raise the height of the unit above the supporting surface (from 2" to 12", in 2" increments), and the nut / bolt combinations re-assembled. The actual installation location will determine the leg height required, we recommend a minimum height of 6" above the supporting surface for drain line (hose) attachment.

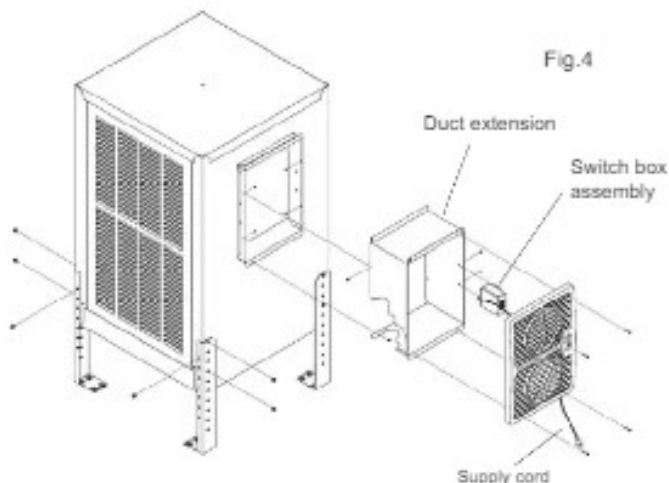

### Attach duct extension, re-locate switch assembly

Thru-the-wall installations require that the duct of the Cool Tool model CTV2 must be extended using the supplied duct extension. The switch box assembly and power supply cord must be re-located for proper operation of the cooler once the grille has been reinstalled.

Convert the cooler duct using the following steps: (see fig 4) **SAVE ALL SCREWS, THEY WILL BE RE-USED.**

- Carefully mark on the power supply cord where the cord exits the grille, this mark will be used when replacing the cord after the thru-the-wall installation is complete.
- Remove the 4 screws holding the grille assembly to the duct. Carefully pull the grille away from the duct and observe how the power cord is routed through the grille, you will need to route the cord in the same way later when reassembling the grille to the duct. Remove cord from grille assembly.
- Remove the 2 screws holding the switch box assembly to the duct. Keep switch box and cord out of the way by carefully placing them on top of blower wheel until repositioned.
- Orient duct extension so that the hooked flange of the extender can be placed over the top flange on the existing duct. Align the duct extension vertically with the existing duct and rotate downward into position, placing the sides of the extension to the outside of the existing duct side flanges.
- Align the holes in the bottom flanges of both the extension and the existing duct (where the lower grille screws were located). Secure the duct and extension using the two #8 thread-forming screws from the hardware bag.
- Using the four #8 nuts and bolts provided in the hardware bag, secure the extension sides to the existing duct.
- Re-locate the switch box assembly to the new mounting holes located in the extension using the old screws. NOTE: the grille will be remounted after the thru-the-wall portion of the installation has been completed.
- Verify that the "Cool" and "Fan" switches are in the **OFF** position before continuing the installation of this unit.

## Wall penetration (duct and grille)

Before locating and cutting a hole through the wall for the duct and grille, observe the following precautions:

### **CAUTION:**

Installation work and electrical wiring must be done in accordance with all applicable building codes and standards, including fire rated construction.

When cutting or drilling into the wall, do not damage electrical wiring or other hidden utilities (water or gas lines, sewer lines, etc.).

1. Locate cooler on support pad and slide into position with duct assembly against the outside wall; mark the duct location. Pull unit away from wall to allow next step.
2. Cut the outlined opening through the wall, making sure it is just large enough to allow passage of the cooler duct (you will need to fill and seal this area to prevent rain, blowing dust/dirt, insects, etc. from entering the indoor space).
3. Slide the cooler into place with the duct assembly protruding slightly beyond the inside wall.
4. Route the power cord through the grille and out of the slots in the grille frame (see Fig 5), using the mark made earlier on the cord to put it back in the proper location. Place the grille assembly on the modified duct extension and secure, using the 4 screws removed prior to the duct extension modification (page 3).
5. Slide cooler back until grille is flush against inside wall, taking care not to pinch or kink the power supply cord.
6. Seal any gaps between the duct and the outside wall (inside wall too, if necessary) to prevent rain leakage, etc.

## Install drain bushing and standpipe

Install overflow drain bushing in bottom of cooler. Slide rubber washer over drain bushing, push drain bushing through bottom of cooler, and tighten nut. Screw plastic overflow standpipe into the drain bushing and tighten snugly (hand-tight) to prevent leakage. Where conditions allow for drainage, connect a drain line (garden hose) to drain bushing and drain in accordance with local codes.

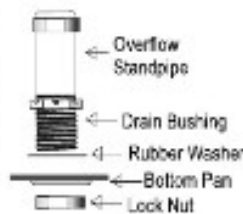

## Connect Water Supply

**CAUTION:** All plumbing installations must comply with local building and safety codes.

NOTE: Coolers should not be connected to "soft" water systems. Soft water will accelerate corrosion and decrease the effective life of pads and cooler cabinet. Connect water line to cooler as follows (see Fig 6):

- A water supply valve should be installed at a convenient location, to allow the water supply to be turned on and off for servicing or winterizing. Minimum 1/4" diameter tubing should be used to provide water to the cooler, larger tubing should be used if the length is greater than 100 feet and reduced to 1/4" at the unit.
- Install float valve in the cabinet.
- Place compression nut and ferrule over end of tubing.
- Connect 1/4" tubing from water supply to float valve.
- Insert tube into float valve, and tighten to secure.

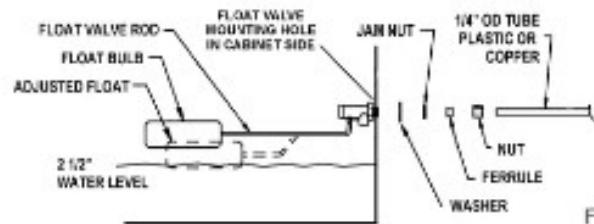
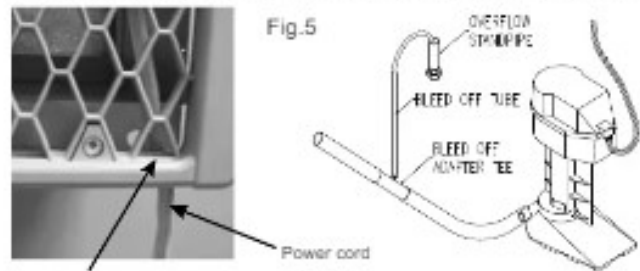

Fig. 6

## Install Bleed-off

To minimize scale "build-up", use the included bleed-off assembly. Remove the cap from the bleed-off tee, insert the black tubing and route it through standpipe opening (see Fig. 7). To prevent siphoning of the water, make sure that the bleed-off tee is above the water level.



Slots in grille frame

Fig. 7

## Motor and blower wheel check

- Check motor mounting to be sure all screws and nuts are tightened down properly.
- Rotate blower wheel by hand to see that it moves freely without rubbing against housing.

## Belt Adjustment

Correct belt tension and alignment is important as it cuts power consumption and prolongs life of belt and motor. When installing or adjusting belt, loosen the motor adjustment bolts and adjust for proper tension. Align belt vertically by centering motor pulley in-line with blower pulley.



## Electric Power

### **CAUTION:**

- This cooler is designed for connection to 120 volt AC, 60 Hz (cycle) power only. NOTE: Improper voltage will void the pump and/or motor warranties and may cause serious personal injury or property damage.
- This cooler must be plugged into a GFCI protected receptacle, which has been properly installed in accordance with all local and national codes. If you are not sure that the receptacle is GFCI protected, consult with a qualified electrician.
- This cooler is equipped with a power cord having an equipment grounding conductor and grounding plug. Do not attempt to defeat this safety device by removing the grounding pin.

## Cooler checkout and first time start-up

Congratulations, once you re-install the pad frames, your cooler will be complete and ready for use. Please proceed to Pre-startup inspection checklist on page 5 before starting unit for the first time.

## GENERAL INSPECTION

### Pre-Start-up Inspection Checklist

Before start-up of the cooler motor and pump for the first time, or at the beginning of each cooling season, make sure all connections and adjustments have been made.

#### For roll-around coolers:

- ✓ Cooler is on a level surface, casters locked to prevent unnecessary movement (prevent spillage).
- ✓ Power supply cord is plugged into a GFCI protected receptacle; cord is secure from accidental damage.
- ✓ Drain and float valve installed.
- ✓ Water hose connected securely without leaks. Water faucet or supply is turned on.
- ✓ Float adjusted for proper water level.

#### For permanently installed coolers:

- ✓ Cooler is level; duct passage through wall is sealed.
- ✓ Cabinet is securely fastened to mounting surface.
- ✓ Power supply cord is plugged into a GFCI protected receptacle; excess cord is secured to prevent damage.
- ✓ Drain, float valve and bleed-off (if desired) installed. Water lines connected securely without leaks. Water supply turned on.
- ✓ Float adjusted for proper water level.

#### For roll-around or permanently installed coolers:

- ✓ Pad frames and air outlet grille correctly installed.
- ✓ Pump impeller turns freely. Remove impeller cover (see "Cleaning Pump", page 6) and check rotation.
- ✓ Blower wheel, shaft, pulley and motor sheave set bolts/screws are snug. (see page 6)
- ✓ Motor sheave / Blower pulley alignment okay; belt tension okay (see page 4 for instructions).

### Start-up Checklist

**CAUTION:** Never operate unit with pad frame(s) and/or air outlet grille removed. This will result in an overloaded condition and may damage the fan motor. The motor and pump have an internal automatic thermal overload switch that will shut the motor and/or the pump off if it overheats! The motor and/or pump can restart automatically when they cool down.

To verify and check out the cooler installation on initial start-up, the following procedure should be followed.

- ✓ Push "COOL" switch to ON position (pump on).
- ✓ Verify that pump starts and pads are evenly wet.
- ✓ Open windows, doors or vents in building.
- ✓ Push "FAN" switch to LOW position (low speed on).
- ✓ Observe that motor starts and runs. Check high-speed function by turning "FAN" switch to HIGH (high speed on).

In case of trouble in any of these stages, refer to the Troubleshooting Chart on page 8.

### Cabinet Inspection Checklist

After initial start-up and during periodic inspections, check for and/or observe the following: Refer to the Troubleshooting Chart on page 8 if necessary.

- ✓ Leaks from water lines, pad frames, cabinet, etc.
- ✓ Observe cooler pads for uneven wetting
- ✓ Confirm water level setting is correct.
- ✓ Verify full, even flow in water distribution system.
- ✓ Blower wheel / motor rotates freely.
- ✓ Belt condition / tension / alignment.
- ✓ Check that set screws on pulleys, blower wheel are tight.
- ✓ Check motor mounting and cabinet hardware.

### Extended Shut-down (winterizing) checklist

Any time the unit will not be used for an extended period:

- ✓ Drain all of the water out of the cooler, water supply line and drain line when not used for prolonged periods, particularly at the end of the season (winter).
- ✓ Unplug the cooler power supply cord and secure it out of the way to avoid damage.

## OPERATING INSTRUCTIONS

### Guidelines and location

Always make sure that the roll-around unit is operated on a solid, level surface strong enough to hold its weight (unit can weigh 225 lbs when full). Make sure the two locking casters have been locked to prevent the cooler from accidentally moving while in use. Use caution when rolling the unit to avoid splashing or spilling of water. Unless the move is for a short distance, it is best to drain the unit, move it and then refill it in its new location.

For best results: (roll-around or permanently installed unit)

- Turn pump on a few minutes before starting the fan, this allows the pads to pre-wet and avoids a blast of warm air.
- Turn pump off a few minutes before turning the fan off. This will allow the pads to dry out, helping to prevent stale or musty odors the next time the unit is started.
- Whenever possible, operate the fan on low speed for maximum cooling.
- When cooling is not required, you can operate this unit by turning on the fan only (leaving the pump turned off).

### Controls

Rocker-type control switches are used to select the operating mode of the cooler. These switches control fan speed (FAN-HIGH/OFF/LOW) and the pump operation (COOL-ON/OFF).

To eliminate a rush of warm air when starting the cooler, be sure to turn the pump (COOL) on for a few minutes before turning on the blower motor (FAN) in low or high speed.

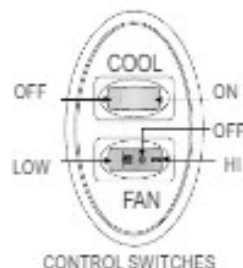

## Maintenance Schedule

Regular maintenance and periodic inspection is a key to long and successful service of your Cool Tool Cooler. The cooler should be serviced at least once a year, or more often if required. For maximum efficiency, longer life and appearance, every two months during operation, the cooler should be inspected and cleaned.

### Note: Do Not Undercoat the Water Reservoir

Your cooler's water reservoir is finished with our Peblar XT® appliance-type finish. It is so hard that asphalt-type cooler undercoating will not stick to it. Undercoating will break free, clogging the pump and water distributor.

**NOTE:** Do not use cooler cleaners, cooler treatments or other chemical additives in this evaporative cooler. Use of any additives or water treatment other than bleed-off will void your warranty and impair the life of the cooler.

Before starting any maintenance operation, read thoroughly all operating and maintenance instructions and observe all cautions and warnings.

**CAUTION:** Disconnect all electrical power to the cooler by removing plug from receptacle before attempting to install, open, or service your cooler.

Even while routinely inspecting or servicing the inside, the cooler can be accidentally started. Keep all personnel away from the cooler and electrical supply when you are working on it. Before servicing or cleaning unit, switch "COOL" and "FAN" to the OFF position and remove power cord from receptacle.

## Cleaning

**CAUTION:** Never wash your cooler cabinet with a garden hose; water may harm motor and pump or seep into ductwork. Motors damaged by water are NOT covered under warranty.

All foreign materials, scale, salt deposits, lime, etc. can and should be removed from louvers, bottom pan, and other components. Your cooler's long lasting finish can be brought to like-new condition by using warm water and a soft cloth.

NOTE: Avoid using scouring pads, steel wool or wire brushes, as these will damage the finish and encourage corrosion.

## Maintenance & Inspection

**CAUTION:** Disconnect all electrical power to the cooler by removing the plug from the receptacle before attempting to install, open, or service your cooler.

**IMPORTANT:** Before operating cooler at beginning of each cooling season, turn blower wheel, cooler motor and pump motor shafts by hand to make sure they turn freely. Failure to do so may result in burning out motor.

Periodic inspection of your cooler will enhance the chance for long, trouble-free service life. For maximum efficiency, every two months during operation, or any time the cooler is opened, the cooler should be inspected. Some suggested items:

- ✓ Check for leaks from pad frames, cabinet, etc.
- ✓ Are there any dry spots on the media when cooler is in operation?
- ✓ Are bolts, nuts and set screws snug?
- ✓ Are the bearings making unusual noises?
- ✓ Does the blower wheel turn freely?
- ✓ Is float level set correctly?
- ✓ Is water in the bottom pan clean?
- ✓ Belt condition / tension / alignment?

## Set Screws, Bolts and Nuts

Check torque on set screws and cabinet hardware:

- ✓ Motor and Blower Pulley set screws (95 in-lbs.)
- ✓ Blower Wheel set screws (1 per side, 150 in-lbs)
- ✓ Cabinet hardware (25 in-lbs)

## Adjust Belt Tension

**CAUTION:** Disconnect all electrical power to the cooler and insure that belt is not rotating before adjusting belt tension

Each time you inspect your cooler, be sure to check belt tension on motor/blower assembly. Check belt condition and replace it if frays or cracks appear. Check alignment of blower pulley with motor pulley (see page 4 for detailed steps).

## Cleaning Water Pump & Hose

**CAUTION:** Do not allow pump to fall over and become submerged; water will damage pump motor.

Clean water pump and hose assembly as follows:

1. Unplug pump cord, remove mounting bracket screw and remove pump from cooler. Shake gently to remove water.
2. To prevent breakage, carefully release and remove impeller base plate from the pump body. (see figure 9)
3. Using a mild detergent solution and clean cloth, clean deposits from pump screen, around impeller and base plate.
4. Spin impeller to dislodge any foreign material.
5. Remove any foreign material in the adapter between the pump and hose, or between the hose and the water distributor assembly.
6. Rinse and reinstall impeller base plate.
7. Reinstall pump and reconnect pump cord.

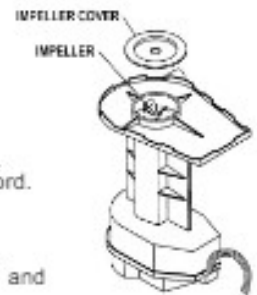

## Draining

Drain the cooler cabinet (with power off and panels removed) as follows:

1. Connect a drain hose to the drain fitting on the bottom of the reservoir, if not already connected to drain line.
2. Remove overflow standpipe from the drain fitting.
3. Drain, clean and dry reservoir.

## Touch-Up

The hardness, adhesion and smoothness of the internal and external finish on your cooler makes it extremely unlikely that scratches, chipping will occur. In the event that finish damage does occur, should be promptly repaired by the following procedures:

1. Sand the area around bare metal spots.
2. Prime and paint with a quality paint.

**Do not use asphalt type cooler undercoat material in water reservoir. Undercoat will break free, clogging the pump and water distributor.**

## LUBRICATION

### Motor Bearings

CoolTool motors have oil ports for lubricating the motor and are oiled at the factory. They should be checked after 20-30 days of operation. If the need for oiling is indicated, see the motor nameplate for specific instructions on re-lubricating the motor. Under normal use, these motors require oiling about every 12 months of operation. **Do Not Over-Oil.**

### Blower Shaft Bearings

Blower shaft bearings need periodic lubrication. The oil cups on the bearings should be filled with a good grade of SAE 30W non-detergent oil when necessary. Under normal use, oiling is required every three months of operation. **Do Not Over-Oil.**

### Pump Bearings

The pump motor bearings are permanently lubricated

## Changing Cooler Pads

Your cooler pads should be changed at least twice a year... at the beginning of a season and midway through. However, your pads may need to be changed more frequently, depending on local air and water conditions. For instance, in areas where mineral content of the water is high, deposits may build up in the cooler pads, restricting airflow. Replace pads as follows:

1. Remove pad assembly from cabinet.
2. Remove pad retainers from frame, using caution as retainers can spring back. Carefully remove all aspen from retainers. Remove and discard old pads.
3. Using a mild detergent, wash dirt and scale from pad frames. Wire brushing is not recommended. If finish is damaged or rusting is noted, repair area as noted in the "Touch-Up" section. Rinse with fresh water.
4. Lay new pad in frame, starting at trough end, making sure pad is snug against trough and outer edges with no air spaces. **Note:** Pad must completely fill frame or hot air may enter building.
5. Pad thickness should be uniform across the frame.
6. Replace pad retainers and lock under edge of frame. Sharp points must be buried into pad (holds pad in place and prevents sagging).
7. Pre-soak pads and check for air gaps along edges, reinstall pad frames into unit.
8. Start pump and allow troughs to fill... check water level in troughs by slightly tilting each pad frame out.

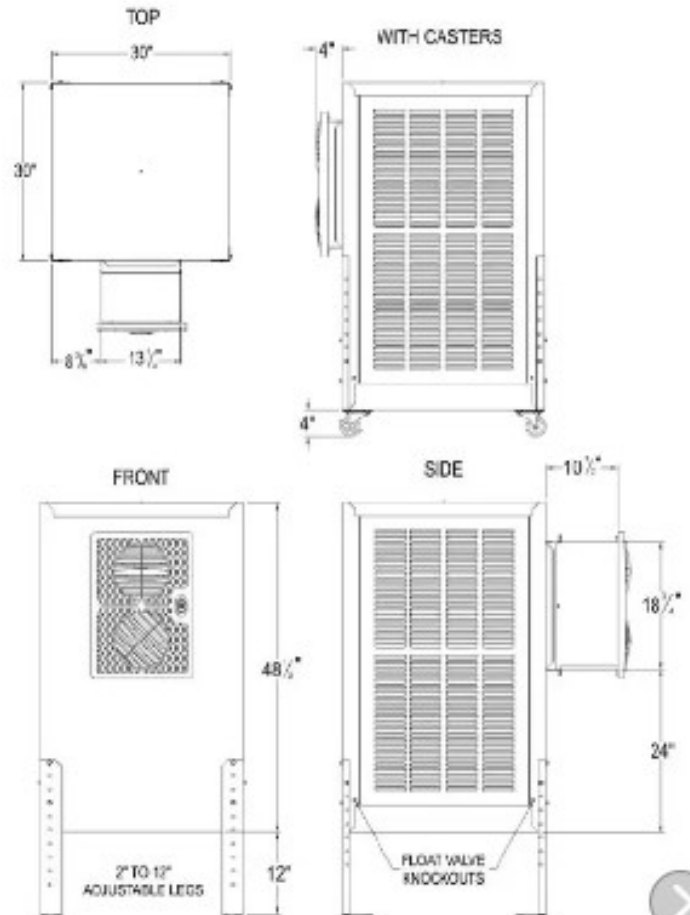
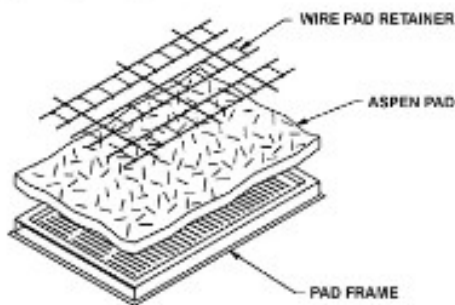

## UNIT DIMENSIONS

## Replacement parts

When ordering replacement parts, always refer to the serial and model number of your cooler. Use the part numbers listed in the accompanying parts list, as illustrated in the diagrams for your model.

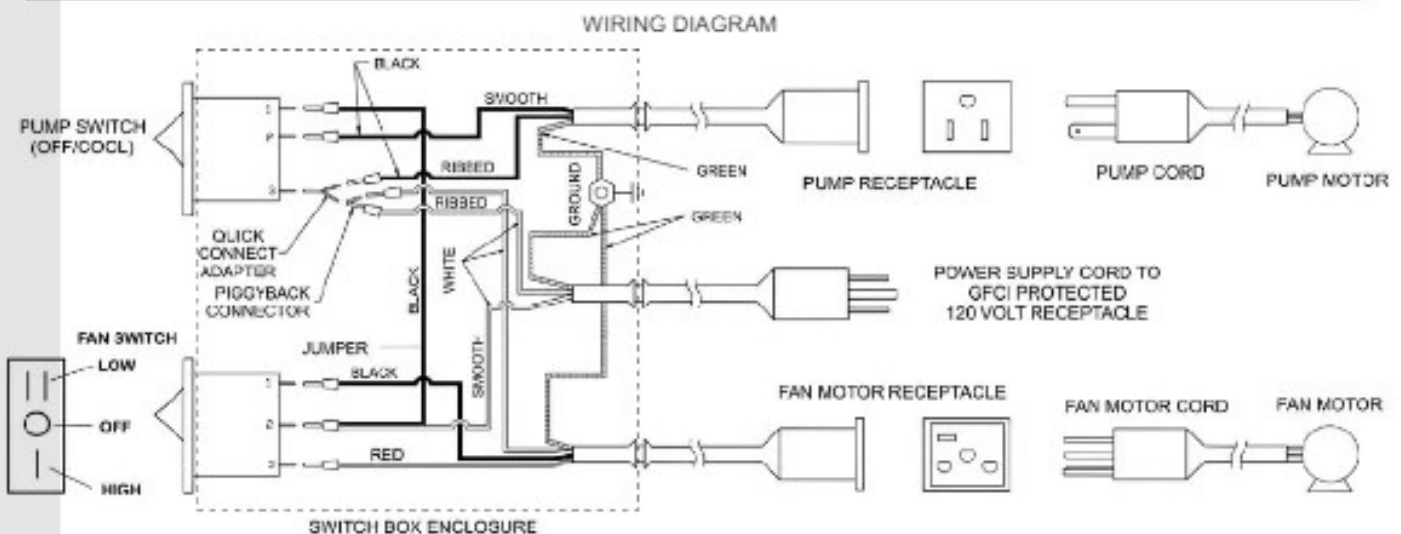

**TROUBLESHOOTING GUIDE:**

Should an obvious problem occur with your cooler consult the following table. If you cannot correct the problem, or if it persists, contact qualified service personnel.

PROBLEM / SYMPTOM	POSSIBLE CAUSE	CORRECTIVE ACTION
Water draining from unit	Float valve out of adjustment	Adjust float to 2 1/2" water depth
	Float movement obstructed	Free float from obstruction
	Float valve non-functional	Replace float assembly
Dry pads	Pump intake clogged	Remove obstruction
	Water pump non-functional	Replace water pump
	Clogged water line	Locate and free obstruction
	Pad trough clogged	Clear debris from trough
	Switch non-functional	Replace switch
	Wiring non-functional	Repair or replace non-functional wiring
	Water turned off to cooler	Turn on water supply
Motor does not start or no air delivery	Electrical power disconnected	Check power receptacle and cord
	Belt too loose or too tight	Adjust belt tension
	Non-functional motor	Replace motor
	Non-functional switch	Replace switch
	Broken belt	Replace belt
Inadequate air delivery	Insufficient air exhaust	Open windows to increase air flow
	Belt too loose	Adjust belt tension or replace is needed
	Pads plugged	Replace pads
Motor cycles on & off	Low voltage	Check voltage
	Excessive belt tension	Adjust belt tension
	Blower shaft tight or locked	Oil or replace bearings
	Bearings dry	Oil bearings
	Pad frame(s) or air outlet grille removed	Re-install pad frame(s) or air outlet grille
Noisy operation	Blower rubbing on housing	Reposition wheel
	Motor sheave or blower set screws loose	Tighten set screws
Excessive humidity in house	Inadequate exhaust	Open doors and windows to increase ventilation



## Cool Tool Replacement Parts

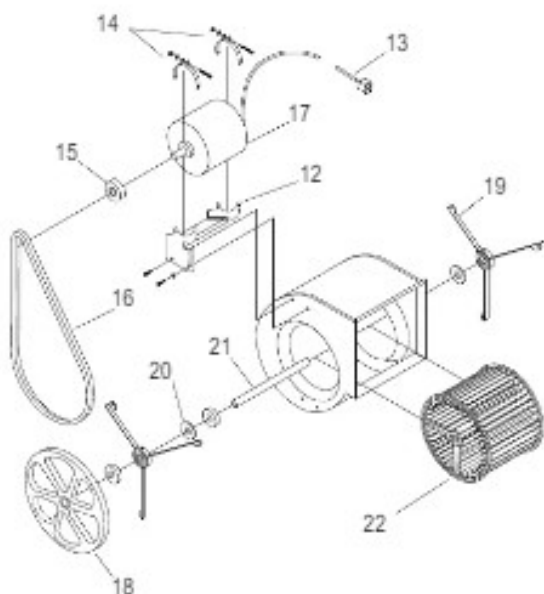

Item	Replacement Part	
1	Cabinet	----
2	Blower Assy. Complete	5-3-111
3	Pad Frame Complete	5-2-124
3a	Pad Retaining Wire	3-2-173
3b	Aspen Pad (pkg. 2)	5-2-219
4	Grille Assembly	5-4-26
5	Switch assembly	5-7-109
6	Duct Extension	5-4-27
7	Float valve	5-6-1
8	Stand Pipe Kit	5-6-5
9	Water distributor Assy.	5-6-204
10	Pump w. pump basket	5-6-34
11	Bleed off Tee & Hose	5-6-3
12	Motor Mount	5-3-112
13	Male Motor Cord	5-7-37
14	Motor Mounting Straps	5-7-28
15	Motor Sheave	5-3-31
16	Blower Belt	5-3-114
17	Bare Motor	5-7-42
18	Blower Pulley	5-3-59
19	Bearing Assy. (2 per pkg.)	5-3-38
20	Leather Washers	5-3-8
21	Shaft	5-3-1
22	Blower Wheel	5-3-113
23	Garden Hose Adaptor *	GHA
24	Leg Set	5-1-80
25	Caster set *	5-1-81

\* Not Shown

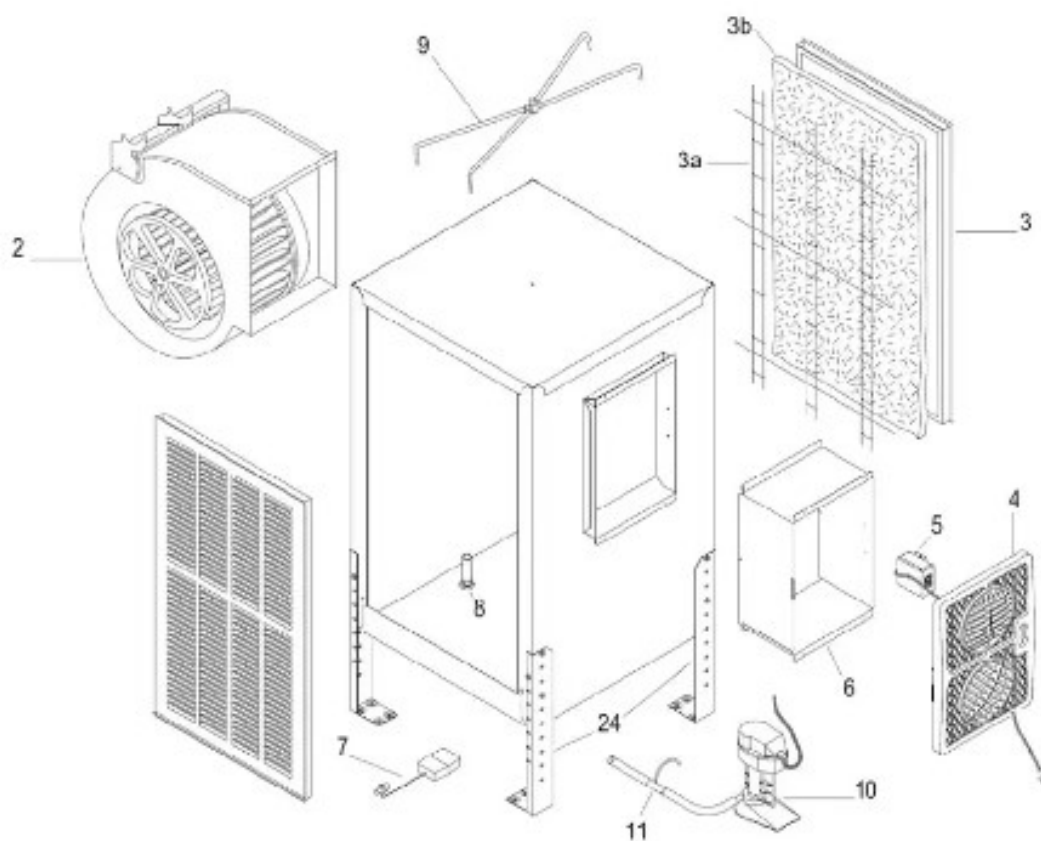

# OPTIONAL AUTOMATIC POWER CLEANING SYSTEM FOR ALL EVAPORATIVE COOLERS.

## FULLY AUTOMATIC:

Fresh water for your evaporative cooler every 12 hours of operation.

- Prevents mineral build-up
- Can save over 3,000 gal./month of water as compared to bleed-off
- Reduces bacterial growth
- Extends pad life
- Reduces maintenance
- Improves efficiency
- Eliminates chemical additives and cleaners which are harmful to your cooler
- Easy plug in installation
- Full 2 year warranty

## FOR ALL EVAPORATIVE COOLERS

Built-in quality and excellent product design create a greater product value for you!

## How it works ....

Once installed, the Power Cleaner System (PCS) will automatically cycle every 12 hours of cooler pump operation to empty the water reservoir within a few minutes. This cycle allows the cooler to re-fill with fresh water. At no time is cooling capability interrupted.

The benefits of fresh water replacement on a regular basis include reduction of mineral scale build-up, bacterial growth control, reduced water consumption (bleed-off is eliminated), easier maintenance and longer pad life WITHOUT the use of harsh chemical additives or cleaners, which are harmful to your cooler. For optimum results, use product with PMI's LSP93 or LSP94 (low sump pump).

**NOTE:** If the power cleaning system is used, disconnect the standard bleed-off system.

For more information on this and other products, contact your local dealer.



PCS115



PCS230

## Evaporative Cooler - Limited Warranty

Phoenix Manufacturing, Inc. (PMI), Phoenix Arizona, extends this limited warranty to the original purchaser of this evaporative cooler.

### What this warranty covers and for how long:

**Ten Year Coverage** PMI will exchange the cabinet should any water leakage occur through the base assembly due to rust out, or as a result of defect in material or workmanship during the first ten years from the date of initial purchase. In lieu of exchange, pro rata credit allowance towards the purchase of a new PMI cooler will be offered.

**Two Year Coverage** applies to all other components except the blower motor. PMI, at their discretion, will exchange or replace all other components except the blower motor should they fail as a result of a defect in material or workmanship during the first two years from date of initial purchase.

**One Year Coverage** applies to the PMI blower motor. PMI, at their discretion, will exchange or replace the PMI blower motor if it fails as a result of a defect in material or workmanship during the first year from the date of initial purchase.

**Media is a disposable item and has no warranty.**

### What this warranty does NOT cover:

PMI is NOT responsible for any damage or malfunction unless caused by a defect in material or workmanship. Determination of defects in materials or workmanship is at the sole discretion of PMI or its appointed representative.

### DAMAGE OR MALFUNCTION, WHICH IS NOT COVERED BY THIS WARRANTY, INCLUDES, BUT IS NOT LIMITED TO:

- |              |                         |                         |   |
|--------------|-------------------------|-------------------------|---|
| ✓ Pad media  | ✓ Water damage to motor | ✓ Abuse or misuse       | ✓ Improper installation, maintenance or operation |
| ✓ Worn belts | ✓ Acts of God           | ✓ Transportation damage |   |

• Do not use anode devices, water from a water softener, cooler cleaners, cooler treatments or other additives in your cooler. The use of any of these products will void your warranty and may impair the life of your cooler.

• This warranty does NOT cover evaporative coolers installed and operated outside the continental United States.

• PMI does NOT pay the cost of a service call to the site or installation to diagnose the cause of trouble.

• PMI does NOT pay the cost of labor to install the part, or mileage allowance to or from the site.

• PMI does NOT pay the freight / postage on any exchange or replacement parts.

• This warranty does NOT cover any failure, damage, or defect that results from unauthorized modification or service, or from the use of products or replacement parts other than those from PMI, including, but not limited to motors and pumps.

### To obtain service under this warranty:

Please write the Warranty Department, PMI, 3655 E. Roeser Road, Phoenix, Arizona, 85040. Include your name, phone number, address and zip code, the servicing dealer involved, the model and serial number of your evaporative cooler, a copy of your proof of purchase, date of installation, and a description of your problem.

### Replacement Parts:

All PMI replacement parts carry a 90-day warranty from date of purchase (or balance of original warranty, whichever is greater).

This warranty is the only warranty extended by PMI to consumer purchasers of evaporative coolers. PMI disclaims all other warranties, expressed or implied, that arise by the operation of the law, except that implied warranties of merchantability or fitness for a particular purpose are limited to the duration of the expressed limited warranty period. PMI shall not be liable to any incidental or consequential damages, above the limitations or exclusions stated above which may have resulted from any alleged breach of warranty.

Some states do not allow limitations on how long an implied warranty lasts or the exclusion or limitation of incidental or consequential damages, the limitations or exclusions stated above may not apply to you. This warranty gives you specific legal rights, and you may have other rights which vary from state to state.