

Owner's Manual



Liquid Propane Gas Grill

MODEL Y0202XC LP

Natural Gas Grill

MODEL Y0202XC NG

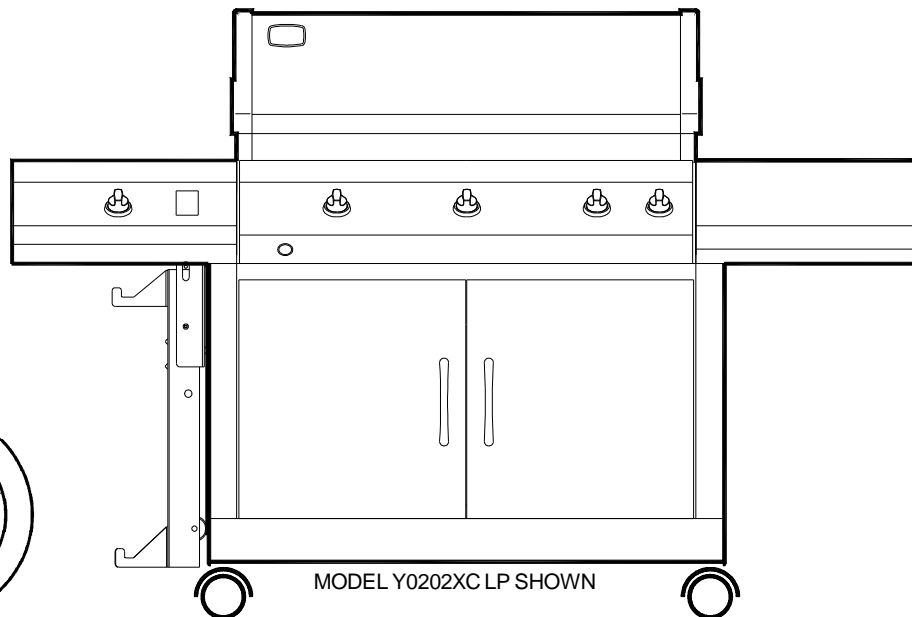

Grill Information Center: If you have questions about assembly or grill operation, or if there are damaged or missing parts when you unpack this unit from the shipping boxes, call us 8am - 4:30 pm CST, Monday through Friday at: **1-800-770-9769**

WARNING:

Read this Owner's Manual carefully and be sure your gas grill is properly assembled, installed and maintained. Follow all leak check procedures carefully in this manual prior to grill operation. **Do this even if the grill was store assembled.** Failure to follow these instructions could result in serious bodily injury and/or property damage. This grill is intended for outdoor use only and is not intended to be installed in or on recreational vehicles or boats.

Note to Installer: Leave this Owner's Manual with the consumer after delivery and/or installation.

Note to Consumer: Leave this Owner's Manual in a convenient place for future reference.

Important Note: This grill is manufactured to exact specifications. Model Y0202XC LP is certified for use with LP gas and Model Y0202CX NG is certified for use with Natural Gas. **You can not convert this grill from one fuel type to the other.** For your safety, conversion kits are not available. Any attempt to convert your grill will void your warranty.

Manufacturer:

Grand Hall Enterprise Co., Ltd.
9th Fl., No.298, Rueiguang Rd., Neihu,
Taipei, Taiwan (114)

Table of Contents

Warranty	2
Safety Instructions	2
Natural Gas Safety Instructions	4
Pre-Assembly Instructions.....	5
Hardware, Parts Diagram and Lists	6
Rotisserie, Parts Diagram and Lists	10
Assembly Instructions	11
Lighting Instructions	18
Rotisserie Instructions	20
Back Burner, Rotisserie Instructions	22
Cleaning and Maintenance Instructions	23
Frequently Asked Questions	25
Cooking Instructions	26
Cooking Guide and Recipes	27

Member's Mark Grill Warranty

Full 1-Year Warranty on Grill

For one year from the date of purchase, the Manufacturer will repair or replace, at their option, any grill part (except for paint loss, rusting, AA batteries) that is defective in material or workmanship.

Limited Warranty on Selected Grill Parts

From the date of purchase for the designated time periods stated below, the Manufacturer will replace the following grill parts if they are defective in material or workmanship. You will be charged shipping and handling.

- **Lifetime of the grill:** Stainless steel parts (except for discoloration due to normal use or excessive heat, and scratches or dents caused by normal use and improper maintenance). Aluminum Castings (except for paint loss)
- **2 Years:** Cast-iron Burners
- **For Warranty Service:** Call our Grill Information Center 8am - 4:30pm CST, Monday through Friday at 1-800-770-9769

Warranty Restrictions:

- This warranty does not cover surface rust or natural oxidation.
- This warranty is void if grill is used for commercial or rental purposes.
- This warranty applies only when the grill is used in the United States.
- This warranty gives you specific legal rights, and you may also have other rights which vary from state to state. See back cover for warranty details.

FOR YOUR SAFETY

If you smell gas:

1. Shut off gas to the appliance.
2. Extinguish any open flame.
3. Open lid.
4. If odor continues, immediately call your gas supplier or your fire department.

Read These Safety Instructions

FOR YOUR SAFETY

1. Do not store or use gasoline or other flammable vapors and liquids in the vicinity of this or any other appliance.
2. An LP gas tank not connected for use shall not be stored in the vicinity of this or any other appliance.

WARNING

Combustion byproducts produced when using this product contain chemicals known to the State of California to cause cancer, birth defects, or other reproductive harm.

WARNING

Failure to comply with these instructions could result in a fire or explosion that could cause serious bodily injury, death, or property damage.

WARNING

Your grill will get very hot. Never lean over the cooking area while using your grill. Do not touch cooking surfaces, grill housing, grill lid or any other grill parts while the grill is in operation, or until the grill has cooled after use.

Failure to comply with these instructions may result in serious bodily injury.

Grill Installation Codes

This gas grill must be installed in accordance with all local codes. In areas without local codes, follow the latest edition of the National Fuel Gas Code ANSI Z223.1. In Canada, installation must conform to standard CAN/CGA 1b149.1 or 1-b149.2 (Installation Code for Gas Burning Appliances and Equipment) and all local codes.

Correct LP Gas Tank Use

LP gas grill models are designed for use with a standard 20 lb. Liquid Propane Gas (LP gas) tank, not included with grill box. **Never** connect your gas grill to an LP gas tank that exceeds this capacity. A tank of approximately 12 inches in diameter by 18-1/2 inches high is the maximum size LP gas tank to use. **You must use an "OPD" gas tank which offers an Overfill Prevention Device.** This safety feature prevents the tank from being overfilled which can cause malfunction of the LP gas tank, Regulator and/or grill.

The LP gas tank must be constructed and marked in accordance with specifications of the U.S. Dept. of Transportation (DOT). In Canada, the LP gas tank must meet the Canadian Transportation and Communications (CTC) specifications. Also be sure to read and follow all LP gas instructions on the following page.

1. The LP gas tank has a Shut Off Valve, terminating in an LP gas supply tank valve outlet, that is compatible with a Type 1 tank connection device. The LP gas tank must also have a safety relief device that has a direct communication with the vapor space of the tank.
2. The tank supply system must be arranged for vapor withdrawal.
3. The LP gas tank used must have a collar to protect the tank valve.

Proper Placement and Clearance of Grill

Never use your gas grill in a garage, porch, shed, breezeway or any other enclosed area. Your gas grill is to be used **outdoors only**, at least 24 inches from the back and side of any combustible surface. Your gas grill should not be placed under any surface that will burn. Do not obstruct the flow of ventilation and combustion air around the gas grill housing.

This outdoor gas grill is not intended to be installed in or on recreational vehicles and/or boats.

⚠ WARNING

Failure to comply with these instructions could result in a fire or explosion that could cause serious bodily injury, death, or property damage.

- **Never** connect an unregulated LP gas tank to your gas grill. The gas Regulator assembly supplied with your gas grill is adjusted to have an outlet pressure of 11" water column (W.C.) for connection to an LP gas tank.
- Only use the Regulator and Hose Assembly supplied with your gas grill. Replacement Regulators and Hose Assemblies must be those specified by manufacturer.
- Have your LP gas tank filled by a reputable propane gas dealer and visually inspected and re-qualified at each filling.
- Never fill the gas tank beyond 80% full. Have your propane gas dealer check the release valve after every filling to ensure that it remains free of defects.
- Always keep LP gas tanks in upright position.
- Do not store (or use) gasoline or other flammable vapors and liquids in the vicinity of this gas grill.
- An LP gas tank that is not connected for use must NOT be stored on bottom shelf inside cabinet or in the vicinity of this or any other gas grill.
- Do not subject the LP gas tank to excessive heat.
- Never store an LP gas tank indoors. If you store your gas grill in the garage or other indoor location, **always** disconnect the LP gas tank first, store it safely outside.
- LP gas tanks must be stored outdoors in a well-ventilated area and out of the reach of children. Disconnected LP gas tanks must not be stored in a building, garage or any other enclosed area.
- When your gas grill is not in use the gas must be turned off at the LP gas tank.

- The Regulator and Hose assembly must be inspected before each use of the grill. If there is excessive abrasion or wear or if the hose is cut, it must be replaced prior to the grill being used again.
- Keep the gas Regulator Hose away from hot grill surfaces and dripping grease. Avoid unnecessary twisting of hose. Visually inspect hose prior to each use for cuts, cracks, excessive wear or other damage. If the Hose appears damaged do not use the gas grill, call our Grill Information Center for a replacement, at 1-800-770-9769.
- **Never** light your gas grill with the Lid closed or before checking to insure the Burner Tubes are fully seated over the Gas Valve Orifices.
- **Never** allow children to operate your grill. Do not allow children to play near your grill.

⚠ WARNING

A strong gas smell, or the hissing sound of gas indicates a serious problem with your gas grill or the LP gas tank. Failure to immediately follow the steps listed below could result in a fire or explosion that could cause serious bodily injury, death, or property damage.

- Shut off gas supply to the gas grill.
- Turn the Control Knobs to OFF position.
- Put out any flame with a Class B fire extinguisher.
- Open Grill Lid.
- Get away from the LP gas tank.
- Do not try to fix the problem yourself.
- If odor continues or you have a fire you cannot extinguish, call your fire department. Do not call near the LP gas tank because your telephone is an electrical device and could create a spark resulting in fire and/or explosion.

NOTE: The normal flow of gas through the Regulator and Hose Assembly can create a humming sound. A low volume of sound is perfectly normal and will not interfere with operation of the grill. If humming sound is loud and excessive you may need to purge air from the gas line or reset the Regulator excess gas flow device. This purging procedure should be done every time a new LP gas tank is connected to your grill. For help call the Grill Information Center.

**Grill Information Center, 8:00am-4:30pm
CST, Monday through Friday at:
1-800-770-9769**

Natural Gas Safety Instructions

- Your Natural Gas Grill is designed to operate on Natural Gas only, at a pressure of 7" water column (W.C.) (1/4 psig or 1.75 kpa), regulated at the residential meter. Check with your gas utility company for local gas pressure and with your local municipality for building code requirements. If your residential gas line pressure has not been regulated to 7" W.C., contact your local gas utility company for professional assistance.
- The gas pressure Regulator supplied with this appliance must be used. This Regulator is set for an outlet pressure of 4" W.C.
- It is recommended that a Shut Off Valve be installed at the gas supply source outdoors. Install at a point after the gas pipe exits the outside wall and before the Quick Disconnect Hose, or install it at the point before the gas line piping enters the ground. See Figure 1.

- Pipe sealing compound or pipe thread tape resistant to the action of Natural Gas must be used on all male pipe threads when making the connection.
- Disconnect your gas grill from fuel source when the gas supply is being tested at high pressures. This gas grill and its individual Shut Off Valve must be disconnected from the gas supply pipe system during any pressure testing of that system at pressure in excess of 1/2 psi (3.5kpa).
- Turn off your gas grill when the gas supply is tested at low pressures. The grill must be isolated from the gas supply pipe system by closing its individual Manual Shut Off Valve during any pressure testing of the gas supply pipe system at pressures equal to or less than 1/2 psi (3.5kpa).
- The Quick Disconnect connects to a 3/8 inch NPT thread from gas source. The Quick Disconnect fitting is a hand operated device that automatically shuts off the the flow of gas from the source when it is disconnected.
- The Quick Disconnect fitting can be installed horizontally, or pointing downward. DO NOT install the fitting with the opening pointing upward because the fitting could collect water and debris.
- The Dust Covers (plastic plugs) provided with the Quick Disconnect help keep the open ends clean while disconnected.
- The outdoor connector must be firmly attached to a ridged permanent construction.
- The Quick Disconnect MUST BE installed above ground.
- WARNING:** Do not route the 12 foot Quick Disconnect Hose under a deck. The hose must be visible and inspected prior to each grill use.

Figure 1
(For Natural Gas Model Only)

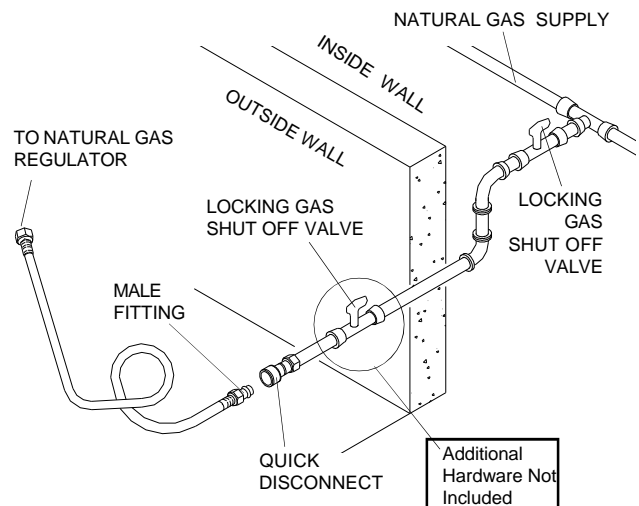

Gas Line Piping

If the length of line required does not exceed 50 feet, use a 5/8" O.D. tube. One size larger should be used for lengths greater than 50 feet.

Gas piping may be copper tubing, type K or L; polyethylene plastic tube, with a minimum wall thickness of .062 inch; or standard weight (schedule 40) steel or wrought iron pipe.

Copper tubing must be tin-lined if the gas contains more than 0.3 grams of hydrogen sulfide per 100 cubic feet of gas.

Plastic tubing is suitable only for outdoor, underground use.

Gas piping in contact with earth, or any other material which may corrode the piping, must be protected against corrosion in an approved manner.

Underground piping must have a minimum of 18" cover.

Test Connections

All connections and joints must be thoroughly tested for leaks in accordance with local codes and all listed procedures in the latest edition of ANSI Z223.1

⚠ DANGER

Do not use an open flame to check for gas leaks. Be sure there are no sparks or open flames in the area while you check for gas leaks. This will result in a fire or explosion which can cause serious bodily injury or death, and damage to property.

CAUTION: BEWARE OF FLASH-BACK

CAUTION: Spiders and small insects occasionally spin webs or make nests in the grill burner tubes during transit and warehousing. These webs can lead to a gas flow obstruction which could result in a fire in and around the Burner Tubes. This type of fire is known as a "FLASH-BACK" and can cause serious damage to your grill and create an unsafe operating condition for the user.

Although an obstructed Burner Tube is not the only cause of "FLASH-BACK", it is the most common cause.

To reduce the chance of "FLASH-BACK", you must clean the Burner Tubes before assembling your grill, and at least once a month in late summer or early fall when spiders are most active. Also perform this Burner Tube cleaning procedure if your grill has not been used for an extended period of time.



Tools Required for Assembly

- Phillips Head screw driver
- Adjustable wrench
- Long nose pliers - used to remove the Cotter Pin when cleaning the Burners
- Open-end wrench (included with Hardware Pack) used to tighten the Casters.
- Protective work gloves
- Eye protection

Pre-Assembly Instructions

To reduce the chance of "FLASH-BACK" (see **CAUTION** at left) clean the Burner Tubes and Burners **before** fully assembling your grill. Remove the Cotter Pin from the rear underside of each Burner using a pair of long nose pliers. Carefully lift each Burner up and away from the Gas Valve Orifice, then refer to **Figure 1** and perform one of these three cleaning methods:

1. Bend a stiff wire, (a lightweight coat hanger works well) into a small hook as shown below. Run the hook through the Burner Tube and inside the Burner several times to remove any debris.



2. Use a Burner Cleaning Brush, or a bottle brush with a flexible handle. Run the brush through the Burner Tube and inside the Burner several times, removing any debris.
3. Use an air hose to force air through each Burner Tube. The forced air should pass debris or obstructions through the Burner and out the ports.

⚠ WARNING

The location of the Burner Tube with respect to the Orifice is vital for safe operation. Check to ensure the Orifice is inside of the Burner Tube before using your gas grill. See **Figure 2**. If the Burner Tube does not fit over the Valve Orifice, lighting the Burner may cause explosion and/or fire.

Figure 2

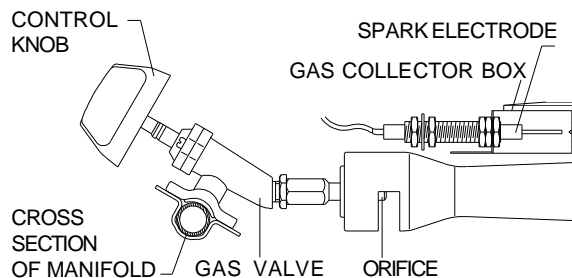
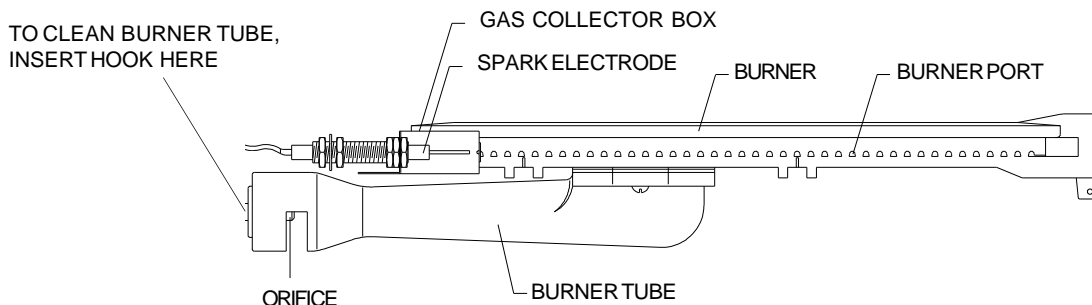

Figure 1



Contents for Hardware Pack

The following table illustrates a breakdown of the Hardware Pack. It highlights what components are used in the various stages of assembly.

Ref.	Component	Qty. to use	Purpose of Component
B.	1/4" x 2 1/2" Phillips Head Screw	2	Attaches Grill Bowl to Cart Leg
N.	1/4" x 3/4" Phillips Head Screw	4	Secures Grill Bowl onto the Cart
L.	1/4" Lock Nut	4	
E.	1/4" x 1/2" Phillips Head Screw	2	Attaches LP Fuel Tank Gauge to Side Cart Panel
E.	1/4" x 1/2" Phillips Head Screw	4	Attaches Tank Hook and Tank Holder to LP Fuel Tank Gauge
K.	3/16" x 1/2" Phillips Head Screw	4	Secures Rear Panel to Cart
E.	1/4" x 1/2" Phillips Head Screw	2	Attaches Door Bracket to the Cart
E.	1/4" x 1/2" Phillips Head Screw	4	Attaches Shelf Bracket to Cart Leg
Q.	M5 x 6mm Phillips Head Screw <i>(already screwed into Door Handles)</i>	4	Attaches the Handles onto the Doors
K.	3/16" x 1/2" Phillips Head Screw	2	Secures the Rear Wind Shield to the back of Grill Cart
E.	1/4" x 1/2" Phillips Head Screw	2	Secures the Spice Tray to Side Shelf
U.	M4 x 10 Self-Tapping Screw	1	
K.	3/16" x 1/2" Phillips Head Screw	2	Secures the Control Panel to Side Burner and Grill Bowl
U.	M4 x 10 Self-Tapping Screw	1	
U.	M4 x 10 Self-Tapping Screw	1	Attaches Manual Lighting Stick to Side Panel
E.	1/4" x 1/2" Phillips Head Screw	4	Secures Side Shelf and Side Burner to Shelf Brackets
K.	3/16" x 1/2" Phillips Head Screw	2	Attaches Natural Gas Regulator to Cart Leg
R.	Manual Lighting Stick	1	Attaches to Right Side Panel
V.	Caster Wrench (Part#P05515109E)	1	Tightens Casters
S.	"AA" Batteries (1 For NG Model) (3 For LP Model)	3	Powers the Electronic Ignition and LP Fuel Gauge Display
T.	Door Handles	2	Attaches to front Doors
V.	Caster Wrench	1	Fixing the Casters
W.	Side Burner Control Knob	1	Attaches on Side Burner Valve
X.	Side Burner Control Knob Seat	1	Attaches on Side Burner Valve
Y.	Spring	1	Attaches on Side Burner Valve

**Contents for Hardware Pack (Part # P06002023A For LP)
(Part # P06002040A For N.G.)**

Actual Size and Quantity of Each Hardware Piece:

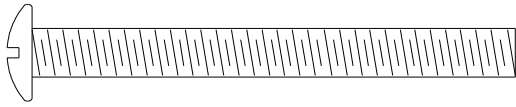

B. 1/4" x 2 1/2" Phillips Head Screw - QTY 2

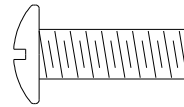

N. 1/4" x 3/4" Phillips Head Screw x 4

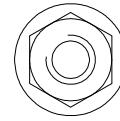

L. 1/4" Lock Nut x 4

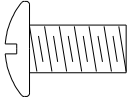

E. 1/4" x 1/2" Phillips Head Screw
QTY. 18 (12 for NG model)

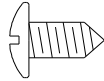

U. M4 x 10 Self-Tapping Screw
QTY. 3



Q. M5 x 6mm Phillips Head Screw
QTY. 4
(found in door handles)

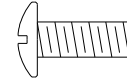

K. 3/16" x 1/2" Phillips Head Screw
QTY. 8 (additional 2 for NG)

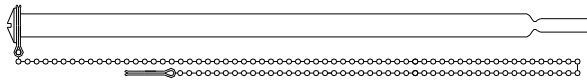

R. Manual Lighting Stick (scale 1/2) - QTY. 1



S. "AA" Batteries - QTY. 3
(1 For NG Model)
(3 For LP Model)



T. Door Handle (scale 1/2) - QTY. 2

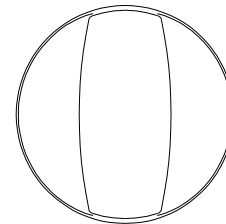

W. Side Burner Control Knob-QTY. 1

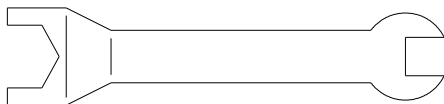

V. Caster Wrench (scale: 1/2)- QTY. 1



Y. Spring-QTY. 1

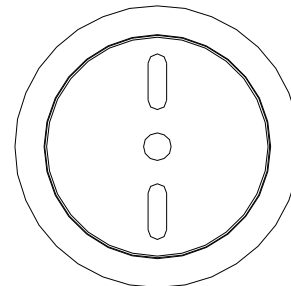

X. Side Burner Control Knob seat-QTY. 1

Grill Information Center: If you have questions about assembly or grill operation, or if there are damaged or missing parts when you unpack this unit from the shipping boxes, call us 8am - 4:30 pm CST, Monday through Friday at: **1-800-770-9769**

Y0202XC Parts Diagram

Remove all components from both cartons and place within easy reach. Turn the largest carton upside down and it will provide a comfortable height work surface for grill assembly.

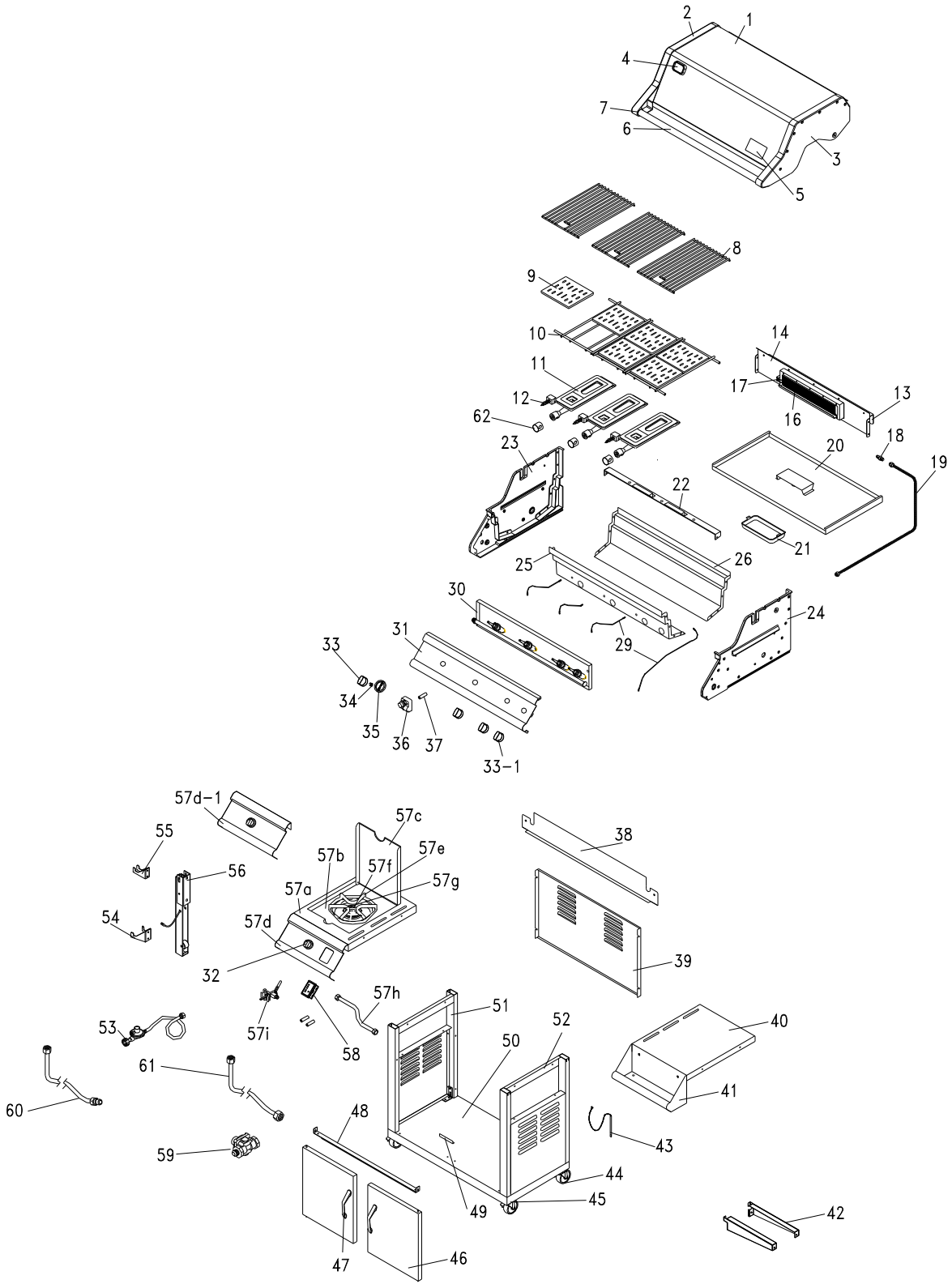

Y0202XC Parts List

REF#	DESCRIPTION	PART#	QTY.	REF#	DESCRIPTION	PART#	QTY.
1.	Lid Plate	P00129306A	1	54.	Tank Holder(LP)	P4042A	1
2.	Lid Side Panel, Left	P00105317T	1	55.	Tank Hook(LP)	P4041A	1
3.	Lid Side Panel, Right	P00106317T	1	56.	Tank Gauge(LP)	P80N5A	1
4.	Temperature Gauge	P0618A	1	57a.	Side Burner Frame	P01102025B	1
5.	Name Plate	P0435C	1	57b.	Side Burner Body	P02301005B	1
6.	Lid Handle	P0234A	1	57c.	Side Burner Lid	P1144A	1
7.	Heat-Insulating Spacer	P5573A	2	57d.	Side Burner Control Panel(LP)	P02904243S	1
8.	Cooking Grid	P01602029C	3	57d-1.	Side Burner Control Panel(NG)	P02904463S	1
9.	Ceramic Flame Tamer	P1736A	6	57e.	Pot Support	P80E4B	1
10.	Rack for Flame Tamer	P1736B	1	57f.	Side Burner	P02002047D	1
11.	Burner	P1925C	3	57g.	Spark Electrode for Side Burner	P2632B	1
12.	Gas Collector Box W. Electrode	P2623B	3	57h.	Connection Hose(7.3")	P03705024A	1
13.	Cover for Back Burner	P06905001B	1	57i.	Gas Valve for Side Burner(LP)	P03232064B	1
14.	Frame for Back Burner	P80F1A	1		Gas Valve for Side Burner(NG)	P03232065B	1
16.	Back Burner	P1947A	1	58.	Tank gauge Display(LP)	P05310031A	1
17.	Spark Electrode	P2515A	1	59.	Regulator (NG)	Y0080007	1
18.	Orifice	P5643A	1	60.	Hose Kit 12ft.(NG)	P3718A	1
19.	Gas Tube Assembly	P3512A	1	61.	Connection Hose (19.8")	P03705036A	1
20.	Grease Draining Tray	P2738B	1	62.	Air Shutter (NG)	P80R7A	3
21.	Grease Receptacle	P2717A	1	----	Owner's Manual	P80146046A	1
22.	Burner Bracket	P0220321AD	1	----	Hardware Pack (page 7)	P06002023A	
23.	Bowl Side Panel, Left	P00705407G	1	----	Hardware Pack(NG)	P06002040A	
24.	Bowl Side Panel, Right	P00706407G	1				
25.	Bowl Front Panel	P00740266D	1				
26.	Bowl Rear Panel	P00741266D	1				
29.	Electric Wire Set	P02615047A	1				
30.	Valve/Manifold Assembly (LP)	Y0060056	1				
	Valve/Manifold Assembly (NG)	Y0060057	1				
31.	Control Panel	P02909233S	1				
32.	Control Knob (Side Burner)	P03424241L	1				
33.	Control Knob (Main Burner)	P03424231L	3				
33-1.	Control Knob (Back Burner)	P03424251L	1				
34.	Spring	P80E3A	5				
35.	Control Knob Seat	P3432A	5				
36.	Electric Ignitor	P02502154C	1				
37.	AA Battery(3 For LP Model) (1 For NG Model)	P8080A					
38.	Rear Wind Shield	P06906003C	1				
39.	Rear Panel	P07701004A	1				
40.	Side Shelf	P01107024B	1				
41.	Spice Tray	P05206009A	1				
42.	Side Shelf Bracket	P01215007D	4				
43.	Manual Lighting Stick	P5540A	1				
44.	Caster	P5115B	4				
45.	Caster Seat	P4525B	4				
46.	Door Plate	P04313008A	2				
47.	Door Handle	P0247A	2				
48.	Door Bracket	P03301014E	1				
49.	Door Stop	P05510089E	1				
50.	Bottom Shelf	P01005019H	1				
51.	Cart Legs,Left(LP)	P00901021B	1				
	Cart Legs,Left(NG)	P00901055B	1				
52.	Cart Legs,Right	P00902021B	1				
53.	Regulator(LP)	P3632N	1				

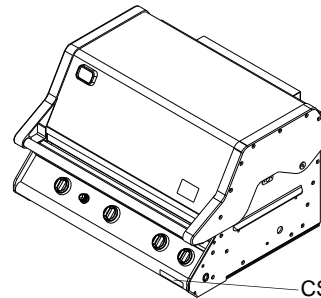

CSA label located here

For the repair or replacement parts you need:
Call our Grill Information Center, 8am - 4:30pm CST,
Monday through Friday at 1-800-770-9769

To make sure you obtain the correct replacement part (s) for your gas grill please refer to the parts list on this page. The following information is required to insure you receive the correct parts:

1. Model and Serial Number (see CSA label on grill)
2. Part Number
3. Description
4. Quantity of parts needed

Please allow sufficient time to process and ship.

IMPORTANT: Keep this Owner's Manual for convenient referral and for part replacement.

IMPORTANT: Use only factory authorized parts. The use of any part that is not factory authorized can be dangerous. This will also void your warranty.

Rotisserie Parts Diagram

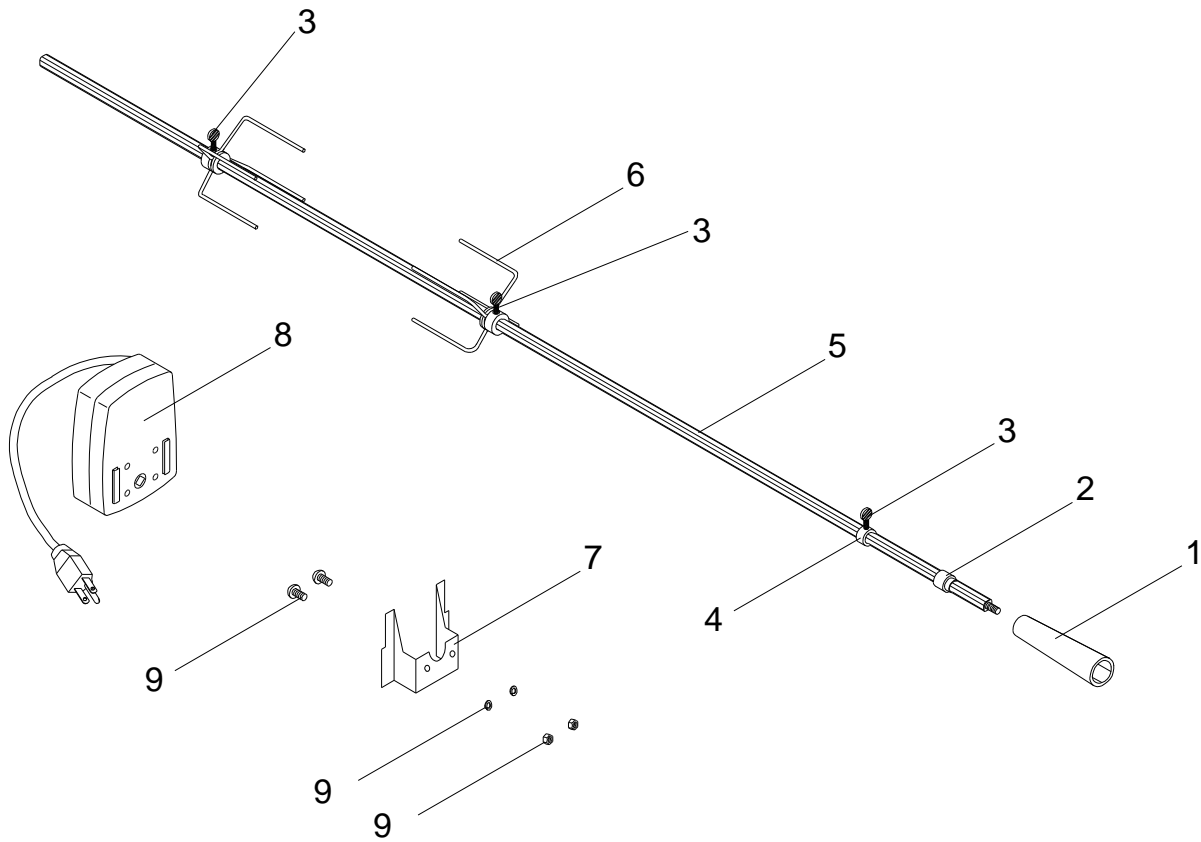

Rotisserie Parts List

REF#	DESCRIPTION	PART#	QTY.
1.	Handle	P8083E	1
2.	Bushing	P05508092F	1
3.	3/8"x1/2" Thumbscrew	P05508094F	3
4.	Collar	P05508091F	1
5.	Skewer	P05508093F	1
6.	Holding Fork	P05508090F	2
7.	Motor Bracket	P8083K	1
8.	AC Rotisserie Motor	P07101010A	1
9.	#10-24x3/4" Screw Washer #10-24 Nut	Y0100052	2

Hardware for Rotisserie

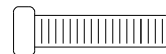

9. #10-24x3/4" UNC Screw
QTY. 2

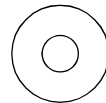

9. Washer
QTY. 2

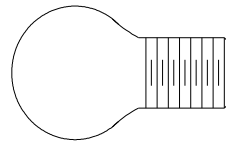

3. 3/8"x1/2" Thumbscrew
QTY. 3



9. #10-24 Nut.
QTY. 2

Cart Assembly Instructions

Remove all cart parts, hardware, and Grill Head from shipping boxes. Raise the Grill Lid and remove all packed components. Use the parts list to check that all necessary parts have been included.

Assemble the gas grill on a protective work surface to avoid scratching grill surfaces. Inspect your grill for damage as you proceed. Do not assemble or operate your grill if it appears damaged. If there are damaged or missing parts when you unpack the shipping boxes, or you have questions during the assembly process, call our Grill Information Center 8am - 4:30pm CST, Monday through Friday at: 1-800-770-9769.

When assembling this grill, we recommend asking for the assistance of another person when maneuvering some of the larger, heavier pieces. You will need both an **Adjustable Wrench** and **Phillips Screw Driver** (not provided) for securing the nuts and screws.

Assembling The Cart

1. Remove cart assembly from shipping box and place on a flat and level surface such as a garage floor. Peel back approximately two inches of the protective PVC film from the front, back and both ends of the Bottom Shelf. Unfold both pre-assembled Cart Legs to an upright position. See **Figure 1**. Push down Cart Legs until Locking Screws snap into the notched holes of the Cart Leg Brackets.
2. Make sure that the Cart Side Panels are flush with the Bottom Shelf. Use a #2 Phillips Head screw driver to tighten both Locking and Pivot Screws for each Cart Leg.
3. Install the 4 Casters to the bottom of the Cart Legs by turning the threaded Caster Stem clockwise until it stops. Tighten securely using the Caster Wrench (included in Hardware Pack). See **Figure 2**.
4. Attach the Rear Panel to the Cart Legs as shown in **Figure 3**. Align the holes on panel with the holes on Cart Legs. Secure loosely using 4 of the "K" 3/16" x 1/2" Phillips Head Screws provided.

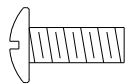

K. 3/16" x 1/2" Phillips Head Screw x 4

5. Secure the Manual Lighting Stick to the top of the right Side Panel. Fix firmly by using the "U" M4 x 10 Self-Tapping Screw packed with the Manual Lighting Stick.

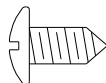

U. M4 x 10 Self-Tapping Screw x 1

Figure 1

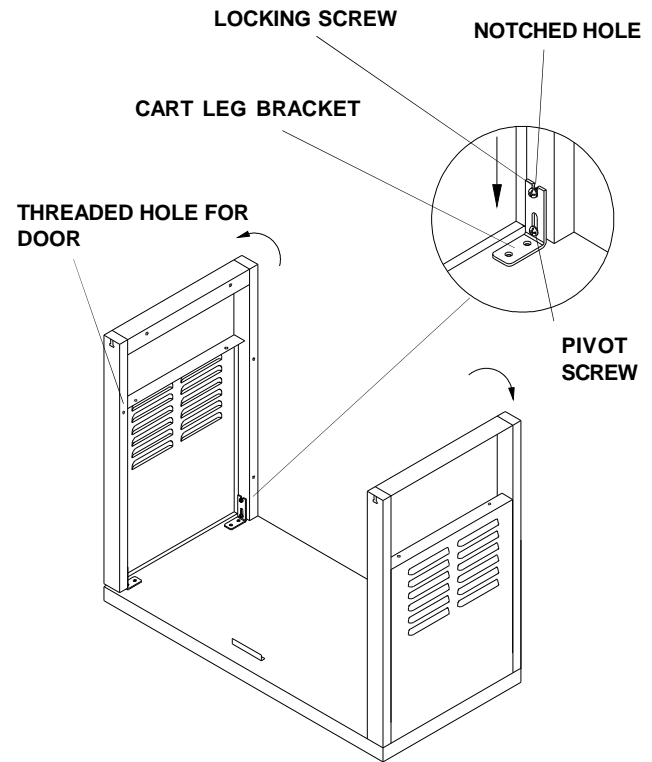

Figure 2

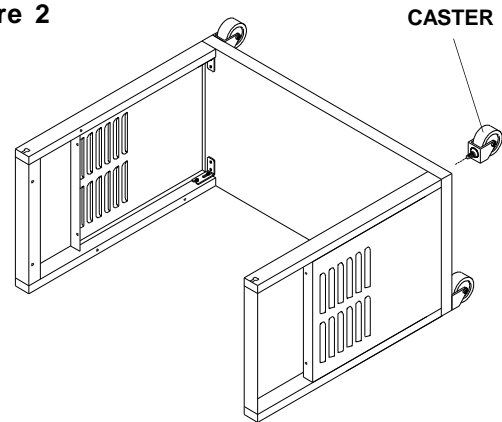
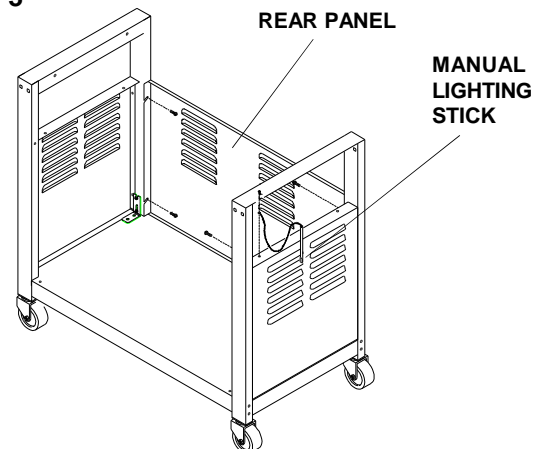
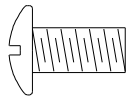

Figure 3



- Attach the Door Bracket to Cart Legs. Be sure the folded strip of the bracket is closest to the Cart Legs. Then align the holes on both ends of the bracket with the threaded holes on the Cart Legs. Attach the Door Bracket using 2 of the "E" 1/4"x 1/2" Phillips Head Screws. Do not tighten screws yet. Refer to **Figure 4**.



E. 1/4" x 1/2" Phillips Head Screw x 2

- Locate the hinge holes on the Bottom Shelf and Door Bracket. Insert the Door Hinges into these holes and holes on Door Bracket. Push the Door Bracket down to an even level. See **Figure 4**. Adjust bottom door stop as necessary to insure that the Door Magnets contact the stop and the Doors are flush with the Bottom Shelf. Unscrew the 4 "Q" M5 x 6mm Phillips Head Screws which were pre-assembled into the Door Handles. Use these screws and a # 2 Phillips Head screw driver to attach the Door Handles to the Door Plate as shown in **Figure 4**.



Q. M5 x 6mm Phillips Head Screw x 4
(found in door handles)

- Insert the 4 Side Shelf Brackets into the open slot at the top section of each Cart Leg. See **Figure 4A**. Secure Brackets using 4 of the "E" 1/4"x 1/2" Phillips Head Screws. Tighten all 4 Brackets securely.

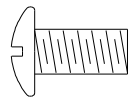

E. 1/4" x 1/2" Phillips Head Screw x 2

Side Shelf Assembly

- Place the stainless steel Side Shelf onto the Side Shelf Brackets previously attached to the right side of the Cart. Align the holes on the Side Shelf with the threaded holes at the end of Shelf Brackets. Secure firmly using 2 of the "E" 1/4"x1/2" Phillips Head Screws. See **Figure 5**.

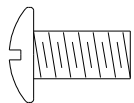

E. 1/4" x 1/2" Phillips Head Screw x 2

- Place the Side Burner onto the Shelf Brackets previously attached to the left side of the Cart. Align the holes on the Side Burner with the threaded holes at the end of Shelf Brackets. Secure firmly using 2 of the "E" 1/4"x1/2" Phillips Head Screws. See **Figure 5**.

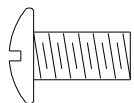

E. 1/4" x 1/2" Phillips Head Screw x 2

Figure 4

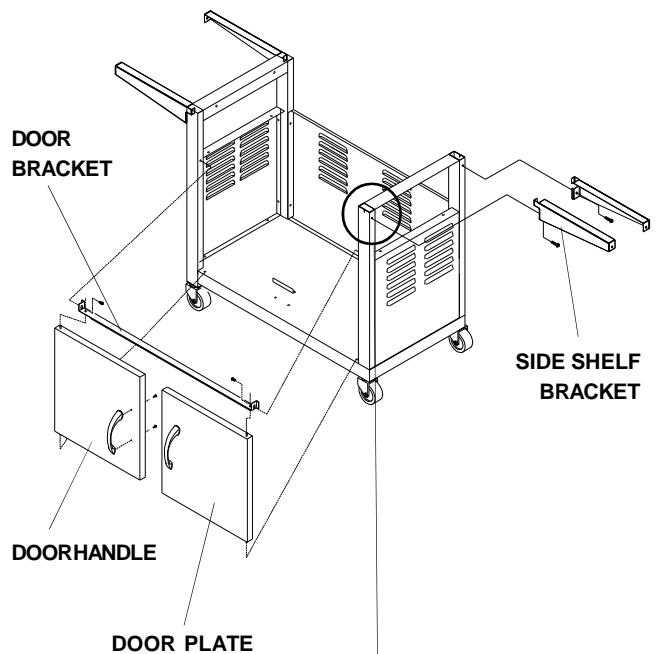

Figure 4A
OPEN SLOT OF
CART LEG

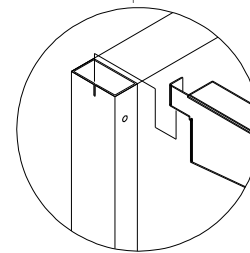
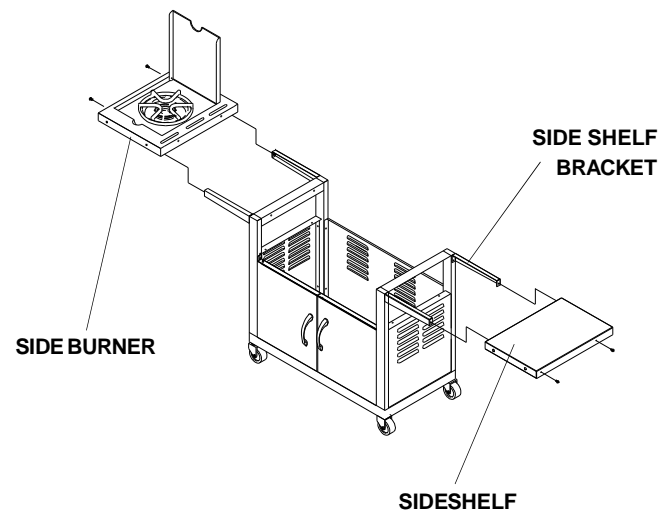
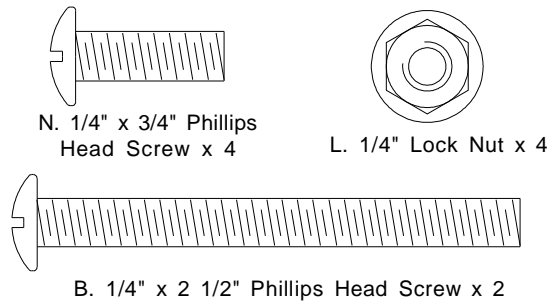

Figure 5



Grill Head Assembly

- Place the Grill Bowl over the assembled Cart as shown in **Figure 6**. Align the holes on both sides of the Grill Bowl with the holes on the Support Bracket. **From the inside of the Grill Bowl**, insert 4 "N" 1/4" x 3/4" Phillips Head Screws and 4 "L" 1/4" Lock Nuts. See **Figure 6A**. Do not tighten yet. You may need to lift the Grill Bowl slightly to align the holes properly. Insert 2 of the "B" 1/4"x 2 1/2" Phillips Head Screws through the Cart Leg and Bowl Panel then tighten securely. See **Figure 6B**. Tighten all Grill Bowl Screws, Rear Panel and Door Bracket Screws that were previously installed.



- From the back of the Grill, slide the Grease Draining Tray into position on the ledges under the Grill Bowl. Center the Grease Receptacle under the Grease Draining Tray. See **Figure 6**.

- Install the Rear Wind Shield to the back of the Grill Cart. Secure using 2 of the "K" 3/16" x 1/2" Phillips Head Screws. See **Figure 7**.

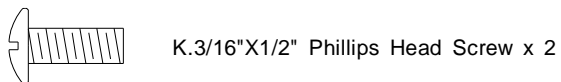

- Insert the Temperature Gauge into the hole on the upper left corner of the Grill Lid. Adjust it to level position, then tighten securely using the Lock Washer and Wing Nut provided in the Temperature Gauge box. See **Figure 8**.

Figure 6

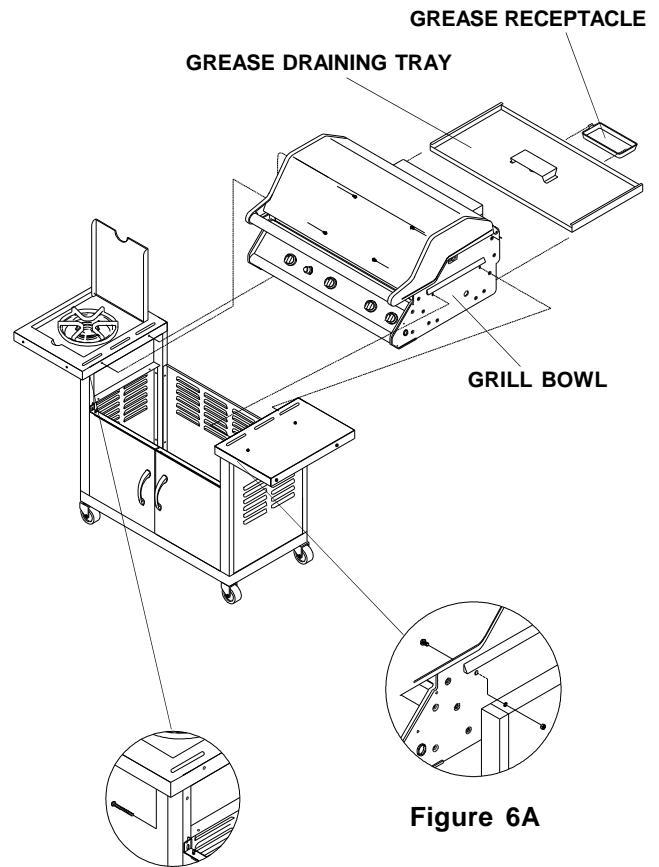

Figure 6A

Figure 6B

Figure 7

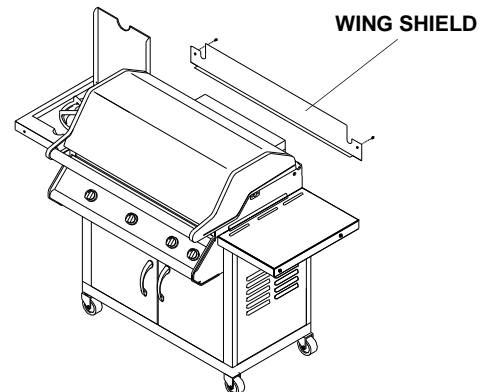
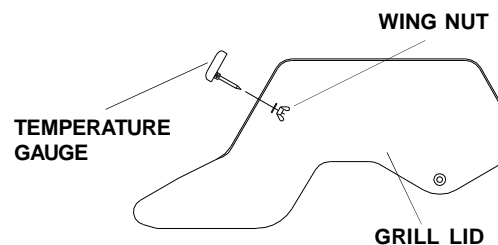
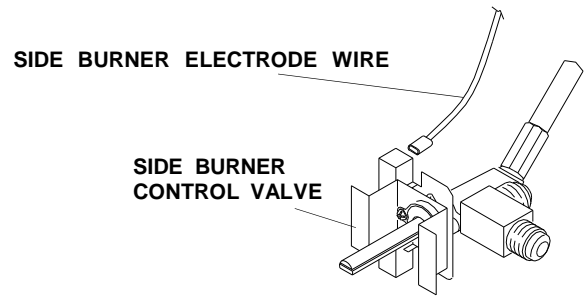

Figure 8



- Attach the Side Burner Electrode Wire to the Control Valve. See **Figure 9**. Attach the Control Valve to the Side Burner Valve Bracket using 2 of the M3x6 screws attached to the Gas Valve. Make sure that the Gas Valve Orifice is seated inside the Burner Tube as shown in **Figure 9A**. Attach the Side Burner Control Panel using 1 of "K" 3/16"x1/2" Phillips Head Screws and 1 of the "U" M4x10 Self-Taping Screws. See **Figure 9B**.

Figure 9



- For Natural Gas Models** attach the Regulator Bracket to Left Rear Cart Leg using 2 of the "K" 3/16"x 1/2" Phillips Head Screws. See **Figure 9C** below.

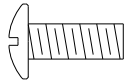

K. 3/16" x 1/2" Phillips Head Screw x2

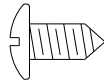

U. M4 x 10 Self-Tapping Screw x1

Figure 9C (Natural Gas only)

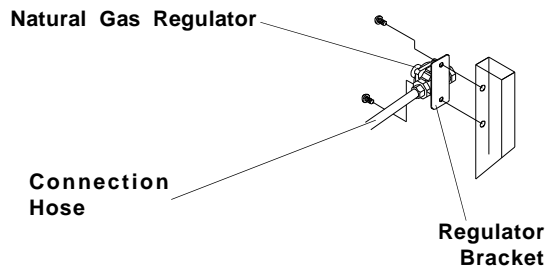

⚠ WARNING

The location of the Burner Tube with respect to the Orifice is vital for safe operation. Check to ensure the Orifice is inside of the Burner Tube as shown below, before using your gas grill. If the Burner Tube does not fit over the Valve Orifice, lighting the Burner may cause an explosion and/or fire. **Figure 9A**

A technical drawing showing a gas valve orifice being inserted into a burner tube. Labels include 'GAS VALVE' and 'ORIFICE'.

- Attach the Spice Tray using 2 of the "E" 1/4" x 1/2" Phillips Head Screws. Secure the Spice Tray firmly using 1 of the "U" M4x10 Self-Tapping Screw. See **Figure 9D**.

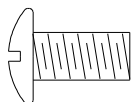

E. 1/4" x 1/2" Phillips Head Screw x 2

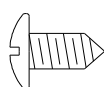

U. M4 x 10 Self-Tapping Screw x 1

- Attach the chrome color Control Knob Seat and Spring onto the Gas Valve stem. Then, carefully attach the Control Knob so the "OFF" position faces upward - toward you. Do not force the Control Knob onto the stem.

Figure 9B

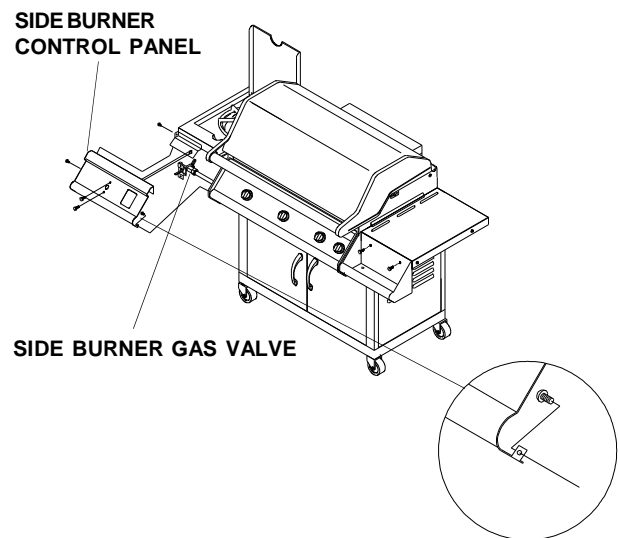
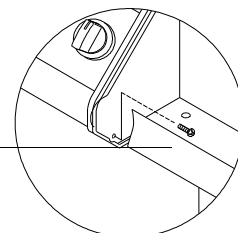

Figure 9D

SPICE TRAY



LP Gas Fuel Gauge Assembly

(See page 4 for Natural Gas Safety and Installation Instructions.)

1. Remove back cover and insert 2 "AA" batteries into Tank Gauge Display battery compartment. See **Figure 10**.
2. Insert the Tank Gauge Display into the rectangular hole on the Side Burner Control Panel. See **Figure 11**.
3. Attach the Tank Gauge to the left Side Panel as shown in **Figure 12**. Align the 2 holes on the Side Panel with the threaded holes on the Tank Gauge. Secure firmly using 2 of the "E" 1/4" x 1/2" Phillips Head Screws.

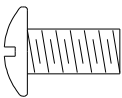

E. 1/4" x 1/2" Phillips Head Screw x 6

4. Attach the Tank Hook to the Tank Gauge. Align the 2 holes of the Tank Hook with the holes on the Tank Gauge and secure firmly by using 2 of the "E" 1/4" x 1/2" Phillips Head Screws. Follow the same steps to attach the Tank Holder.
5. Insert the connection cable terminal (from the Tank Gauge) into Terminal on the left side of the Tank Gauge Display. See **Figure 13**.

Figure 10

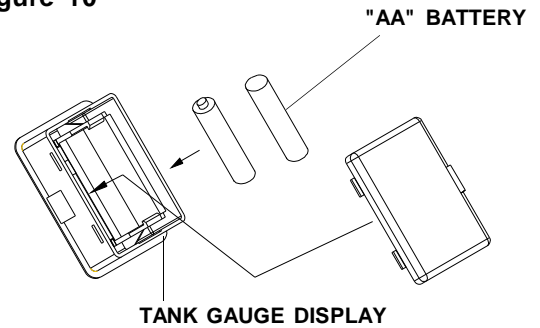

Figure 11

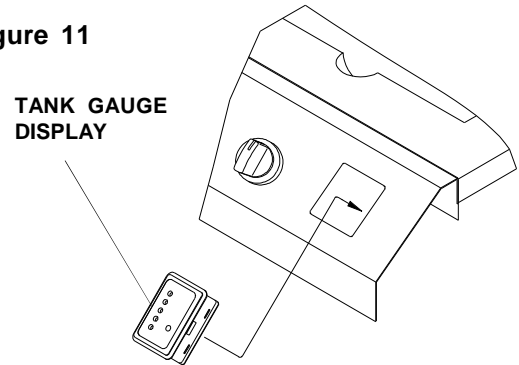

Figure 12

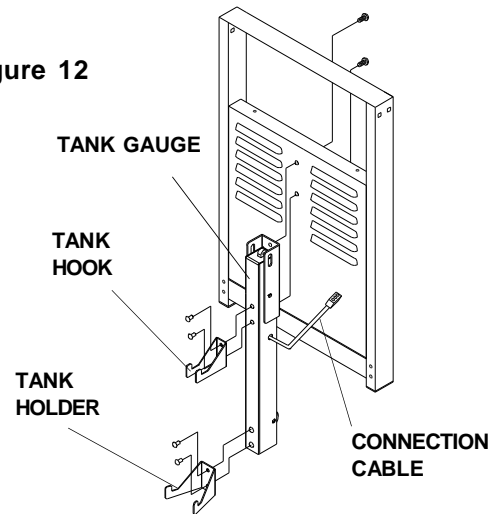
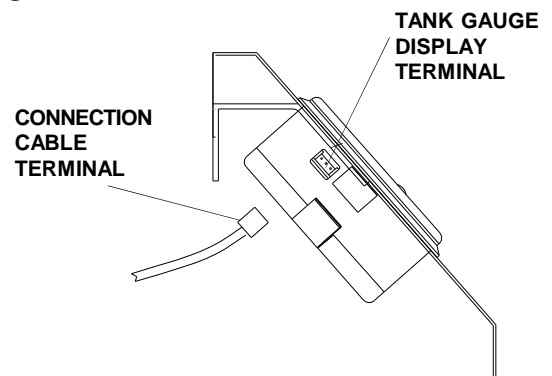

Figure 13



Ignitor Battery Installation - See Figure 14

1. Unscrew the Ignitor Cap located on the Grill Control Panel and remove the Contact and Spring from the Ignitor Slot.
2. Place the manufacturer supplied AA battery into the Ignitor Slot. Be sure to place the positive pole facing toward you.
3. Place the Spring over the AA battery, then place the Contact on top of the Spring. Screw the Ignitor Cap back onto the grill Control Panel.

5. If no "clicking" sound is heard check the following common causes. **If you need assistance call our Grill Information Center at 1-800-770-9769.**

- Ignitor AA battery not installed properly.
- Ignitor wires may be loose. Remove the AA battery, inspect the Ignitor Junction Box found behind the Control Panel, and connect any loose wires.

Electrode Check

Requires and assistant:

Before placing the cooking components into your grill, insure that the Spark Electrode Tip is properly positioned within each Gas Collector Box (stainless steel mechanism found at the front between each set of Burners.) The easiest way to insure this is to perform this Electrode Check:

1. Be sure all Control Knobs are set to "OFF" and open the Grill Lid.
2. Have an assistant stand behind to the right of the grill and look down at each Gas Collector Box. NEVER put your face inside Grill Head.
3. Push in Control Knob and turn counter clockwise until (IGN) is visible. Push Control Knob in. You should hear a clicking sound and your assistant should see a small blue spark within each Gas Collector Box. If a spark is present the Electrode Tips are properly positioned.
4. If no spark is seen the Spark Gap shown in **Figure 15** needs to be adjusted as follows:
 - Using an adjustable wrench, loosen the inside Nut just until the Gas Collector Box can be maneuvered and turned upward.
 - The gap between the Spark Electrode Tip and Spark receiver should be approximately $3/16"$.
 - If the gap is wider than $3/16"$ use a pair of long nose pliers and gently squeeze the Gas Collector Box until the gap is correct.
 - Return the Gas Collector Box to its original horizontal position, secure the inside Nut and try the Electrode Check again.

Figure 14

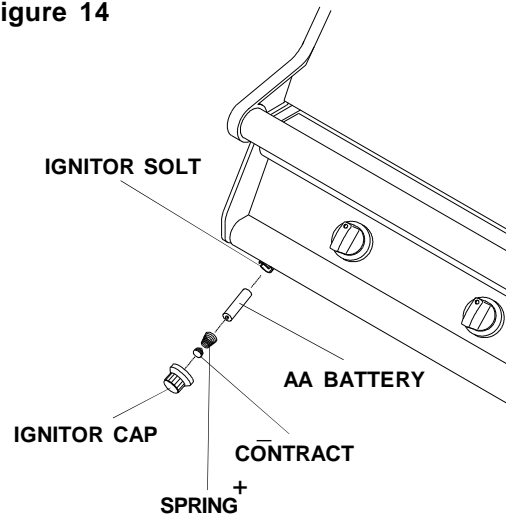
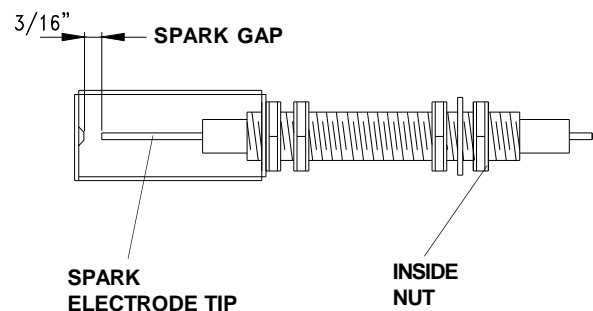

Figure 15 - Side View Gas Collector Box



Grill Information Center: If you have questions about assembly or grill operation, or if there are damaged or missing parts when you unpack this unit from the shipping boxes, call us 8am - 4:30 pm CST, Monday through Friday at: **1-800-770-9769**

Installing Cooking Components

1. Place the Rack for Ceramic Flame Tamers on the lower ledge above Burners. See **Figure 16**. Place all 6 Ceramic Flame Tamers onto the Rack.

Place all Ceramic Flame Tamers into the Rack so they fit as shown in Figure 16. You can use the Ceramic Flame Tamers with small or larger holes facing upward. Either way will not affect the performance of your grill. If they do not fit as shown you need to reverse the Rack.

2. Place Cooking Grids on the ledge above Ceramic Flame Tamers.

IMPORTANT: The Grill is not designed for use with lava rock or briquettes and the use of such items will void the warranty.

Connecting A Liquid Propane Gas (LP gas) Tank To Your Grill

1. Check the Tank Valve to insure it has proper external mating threads to fit the Hose and Regulator Assembly provided. (Type 1 connection per ANSI Z21.58a-1998)
2. Inspect the Valve Connection Port and Regulator assembly. Look for damage or debris. Remove any debris. Inspect Hose for damage. Never use damaged or plugged equipment.
3. Hang your filled gas tank on the Tank Hook. The ring foot of the gas tank will rest on the Tank Display. See **Figure 17**. Make sure the LP gas tank valve is in the full OFF position (turn clockwise to close). **To reset the Tank Gauge, depress the gas tank all the way down using your hand, each time you replace the tank.**
4. Make sure all Burner Valves are in the OFF position.
5. When connecting the Hose and Regulator Assembly to the Tank Valve, hand tighten nut clockwise to a full stop. Do Not use a wrench to tighten because it could damage the Quick Coupling Nut and result in a hazardous condition.
6. Slowly open the tank valve 1/4 to 1/2 open (counterclockwise). Use a soapy water solution to check all connections for leaks before attempting to light your grill. See "Checking for Gas Leaks" on page 17. If a leak is found, turn the Tank Valve off and do not use your grill until the leak is repaired. Do this leak test even if the grill was store assembled.

To connect A Natural Gas (NG) Grill Refer to Instructions on page 4.

Disconnecting A Liquid Propane Gas (LP gas) Tank From Your Grill

1. Turn the Burner Valves and LP Gas Tank Valve to the full OFF position (turn clockwise to close).
2. Detach the Hose and Regulator Assembly from the LP gas Tank Valve by turning the Quick Coupling Nut counterclockwise.

Figure 16

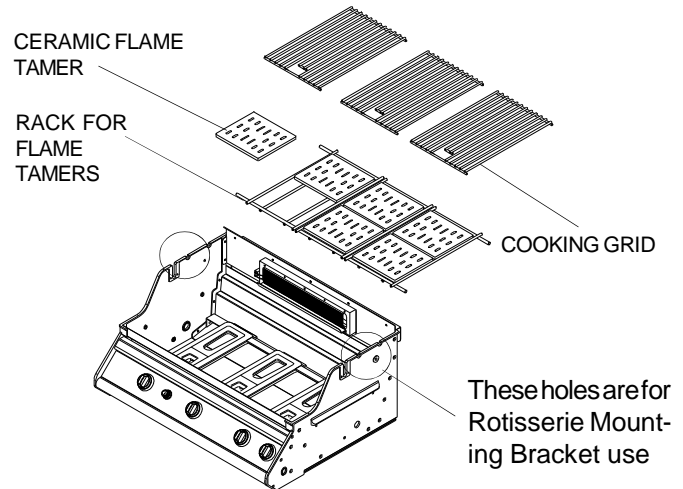
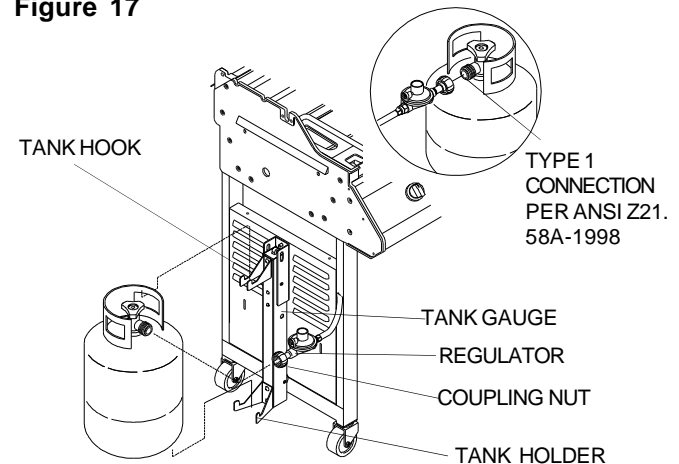

Figure 17



CAUTION: When the appliance is not in use, the gas must be turned off at the supply tank.

Congratulations

Your Member's Mark gas grill is now ready for use. Before the first use and at the beginning of each season (and whenever a LP gas tank has been changed):

1. Read all safety, lighting and operating instructions.
2. Check Gas Valve Orifices, Burner Tubes and Burner Ports for any obstructions.
3. Perform gas leak check according to instructions found on page 17 of this Owner's Manual.

⚠ WARNING

A strong gas smell, or the hissing sound of gas indicates a serious problem with your gas grill or the LP gas tank. Failure to immediately follow the steps listed below could result in a fire or explosion that could cause serious bodily injury, death, or property damage.

- Shut off gas supply to the gas grill.
- Turn the Control Knobs to OFF position.
- Put out any flame with a Class B fire extinguisher.
- Open Grill Lid.
- Get away from the LP gas tank.
- Do not try to fix the problem yourself.
- If odor continues or you have a fire you cannot extinguish, call your fire department. Do not call near the LP gas tank because your telephone is an electrical device and could create a spark resulting in fire and/or explosion.

NOTE: The normal flow of gas through the Hose and Regulator Assembly can create a humming sound. A low volume of sound is perfectly normal and will not interfere with operation of the grill. If the humming sound is loud and excessive you may need to purge air from the gas line or reset the Regulator excess gas flow device. This purging procedure should be done every time a new LP gas tank is connected to your grill. For help call the Grill Information Center for assistance.

**Grill Information Center, 8:00am - 4:30 pm
CST, Monday through Friday at
1-800-770-9769.**

Checking For LP Gas or Natural Gas Leaks

Never test for leaks with a flame. Prior to first use, at the beginning of each season, or every time your LP gas tank is changed, you must check for gas leaks. Follow these four steps:

1. Make a soap solution by mixing one part liquid detergent and one part water.
2. Turn the grill Control Knobs to the full OFF position, then turn the gas ON at source.
3. Apply the soap solution to all gas connections. If bubbles appear in the soap solution the connections are not properly sealed. Check each fitting and tighten or repair as necessary.
4. If you have a gas leak that you cannot repair, turn off the gas at the source, disconnect fuel line from your grill and call 1-800-770-9769 or your gas supplier for repair assistance.

Basic Grill Lighting Instructions

1. Familiarize yourself with the safety guidelines at the front of this manual. Do not smoke while lighting grill or checking gas supply connections.
2. Be sure the LP gas tank is filled or the Natural Gas Quick Disconnect Hose is attached to the gas source.
3. Check that the end of each Burner Tube is properly located over each Valve Orifice.
4. Make sure all gas connections are securely tightened.
5. Open the Grill Lid.

⚠ WARNING

Failure to open Grill Lid during the lighting procedures could result in a fire or explosion that could cause serious bodily injury, death, or property damage.

6. Set Control Knobs to OFF and open the LP gas tank valve slowly until 1/4 to 1/2 open. For Natural Gas open the Shut Off Valve at source completely.

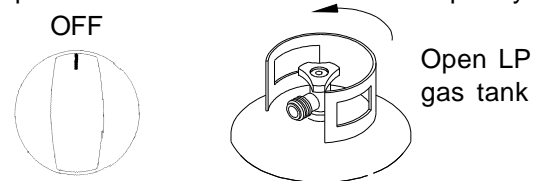

7. It is best to light the Main Burner farthest from fuel source first. Push and turn the third Control Knob from the left to IGN. Push the Control Knob in to automatically ignite the Burner.

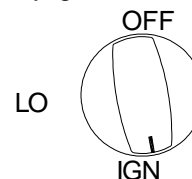

8. If the Burner does not light, turn the Control Knob to OFF, wait 5 minutes for gas to clear, then retry.
9. Once the third main Burner from the left is ignited, the adjacent Burner can be lit by simply turning its Control Knob to HIGH.
10. Adjust Control Knobs to your desired cooking temperature.

VISUALLY CHECKING BURNER FLAMES

Occasionally observe Burner flame for correct operation as shown below:

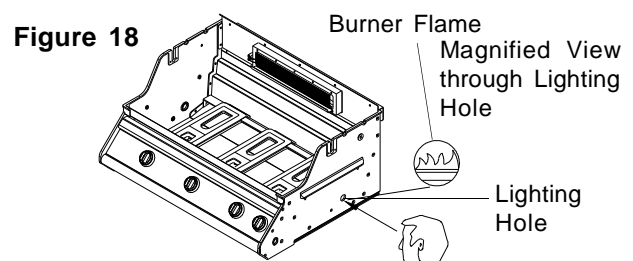

Manually Lighting Your Grill by Match

To light your gas grill by match, insert a match into the Manual Lighting Stick and follow steps 1 through 6 of the Basic Lighting Procedures. Then, light the match and place Manual Lighting Stick through the Lighting Hole on the right side of the grill. See **Figure 19**. Turn the nearest Main Burner Control Knob to the HIGH setting to release gas. The Burner should light immediately.

Figure. 19

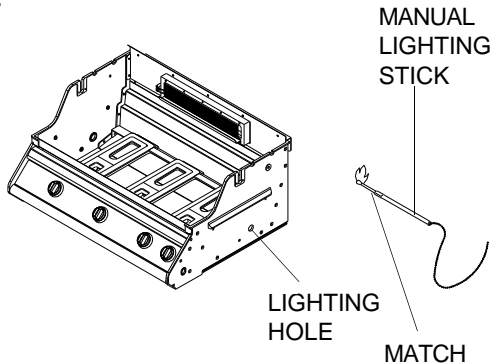

⚠ WARNING

Never lean over the grill cooking area while lighting your gas grill. Keep your face and body a safe distance (at least 18 inches) from the Lighting Hole or Burners, when lighting your grill by match.

If the grill fails to light properly:

1. Turn gas off at source and turn the Control Knobs to OFF. Wait at least five minutes for gas to clear, then retry.
2. Check gas supply and connections.
3. Repeat lighting procedure. If your grill still fails to operate properly, turn the gas off at source, turn the Control Knobs to OFF, then check the following:
 - Misalignment of Burner Tubes over Orifices
Correction: Reposition Burner Tubes over Orifices.
 - Obstruction in gas line
Correction: Remove fuel line from grill. Do not smoke! Open gas supply for one second to clear any obstruction from fuel line. Close off gas supply at source and reconnect fuel line to grill.
 - Plugged Orifice
Correction: Remove Burners from grill by pulling Cotter Pin (beneath Burner) using Long nose pliers. Carefully lift each Burner up and away from Gas Valve Orifice. Remove the Orifice from Gas Valve and gently clear any obstruction with a fine wire. Then reinstall all Orifices, Burners, Cotter Pins and cooking components.

If an obstruction is suspected in Gas Valves or Gas Valve Bracket, please call the Grill Information Center at 1-800-770-9769.

- Misalignment of Ignitor on Burner
Correction: Check for proper position of the Electrode Tip as shown on page 15. The gap between the Spark Electrode Tip and Spark Receiver should be approximately 3/16". Adjust if necessary following the Electrode Check procedure on page 15.
- Disconnected Ignition Wires
Correction: Inspect the Ignitor Junction Box found behind the Control Panel. Connect loose Ignitor wires to Junction Box and try to light grill.
- Weak AA battery
Correction: Unscrew the Ignitor Cap and replace the battery.

To purge air from your gas line and/or reset the Regulator excess gas flow device:

Opening the tank valve all the way or too quickly is what triggers the Regulators safety device to shut down gas flow which prevents excessive gas flow to your grill. Lighting the Burner farthest from the fuel source every time will help eliminate air pockets in the Manifold. This procedure should be done every time a new LP gas tank is connected to your grill:

- Turn all Control Knobs to the OFF position.
- Turn off the LP gas tank valve at the tank valve.
- Disconnect Regulator from LP gas tank.
- Let unit stand for 5 minutes.
- Reconnect Regulator to the LP gas tank.
- Open Grill Lid or Side Burner Lid.
- Turn the LP gas tank valve on slowly until 1/4 to 1/2 open.
- Light the Burner farthest from fuel source by turning its Control Knob to IGN then pushing in the Control Knob. To light the Side Burner push its Control Knob in and turn to HIGH.

⚠ WARNING

Should a "FLASH-BACK" fire occur in/around the Burner Tubes, follow the instructions below. Failure to comply with these instructions could result in a fire or explosion that could cause serious bodily injury, death, or property damage.

- Shut off gas supply to the gas grill.
- Turn the Control Knobs to OFF position.
- Put out any flame with a Class B fire extinguisher.
- Open Grill Lid.
- Once the grill has cooled down, clean the Burner Tubes and Burners according to the cleaning instructions found on page 21 in this manual.

Rotisserie Instructions

1. Remove all components from the carton.
2. Attach the motor bracket on the outside of the left grill bowl panel. Align the two holes of the bracket with the holes on the grill bowl panel. Tighten securely using two No.10-24 x 3/4" UNC screws, flat washers and nuts provided.

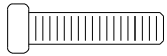

9. #10-24x3/4" UNC Screw x2

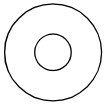

9. Washer x2



9. #10-24 Nut. x2

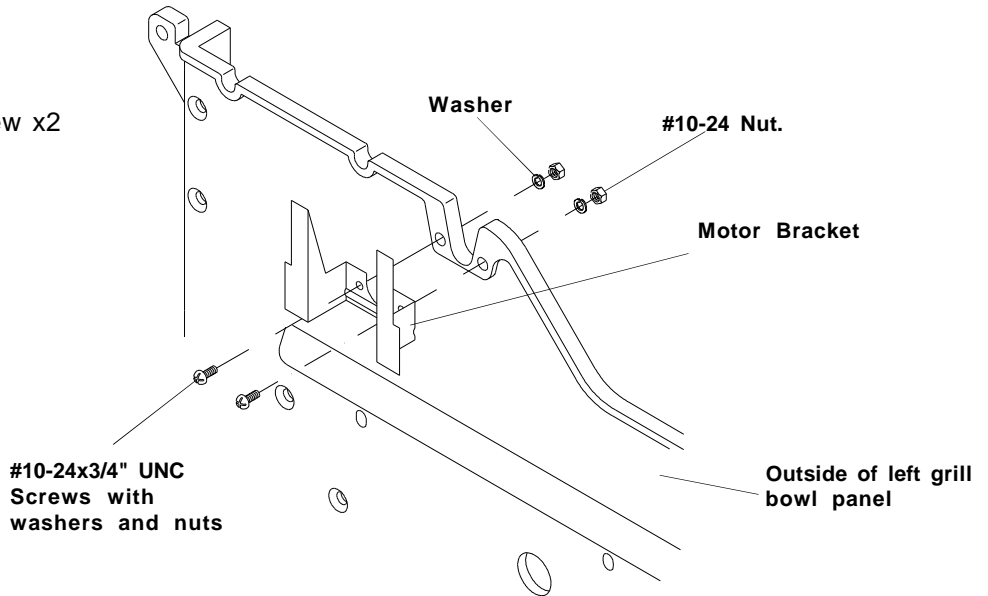

3. Slide a holding fork onto each end of skewer and tighten the thumbscrew to keep the holding forks in place. Slide the collar and bushing onto the threaded end of the skewer. Do not tighten the collar thumbscrew until the rotisserie is placed into the grill. Last, Screw the handle to the threaded end of skewer as shown.

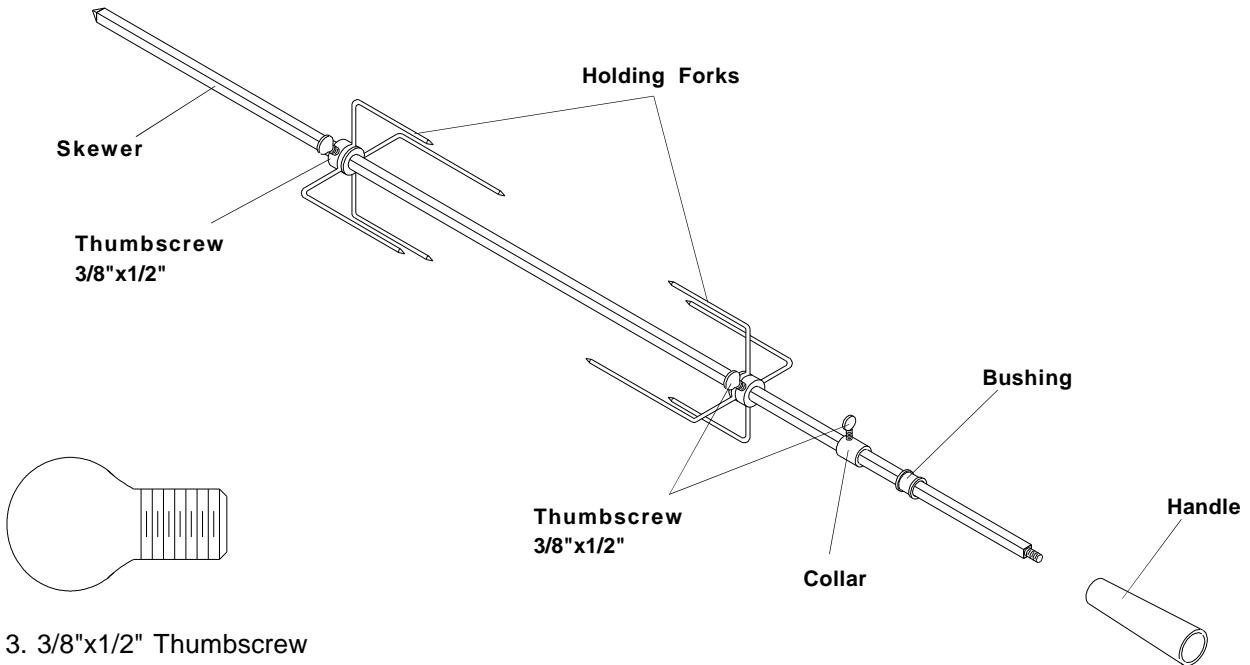

3. 3/8"x1/2" Thumbscrew
QTY. 3

4. Install the AC (alternating current) rotisserie motor onto the motor bracket as shown. This is a universal rotisserie motor designed to fit a variety of grills. On your grill the motor attaches to the bracket with the electrical cord UP, not down. This installation insures that once the skewer is inserted into the motor it will also rest securely into the slot of your grill bowl.

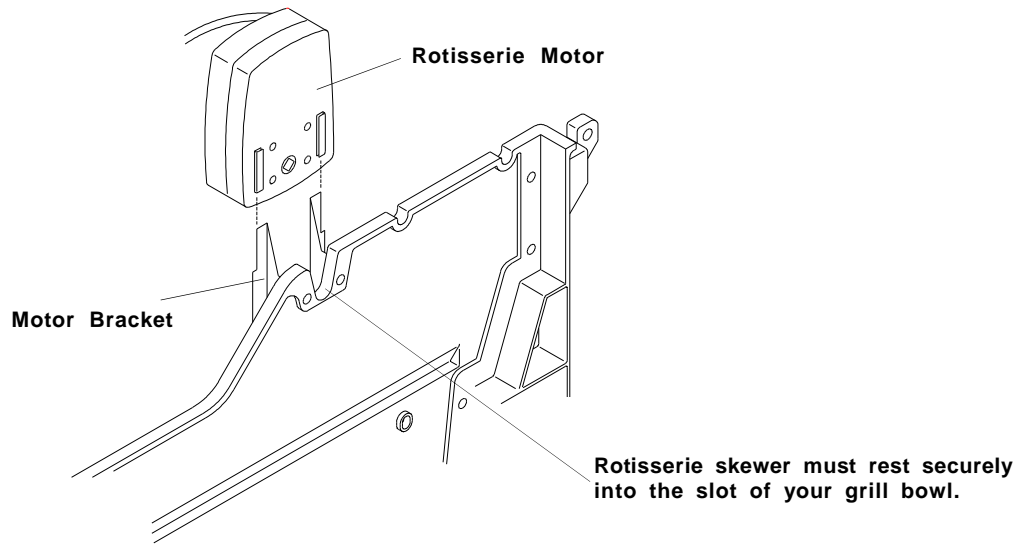

5. Insert the assembled rotisserie into the motor as shown below. The motor should be on the left side of your grill and the handle on the right side. Place the bushing into the slot opening on the right side of your grill bowl. resting the skewer into the slot opening with the bushing just inside the grill bowl, and tighten the collar thumbscrew to the left of bushing, the collar will stabilize the rotisserie during the cooking process. Plug the rotisserie into an outlet and turn on to test.

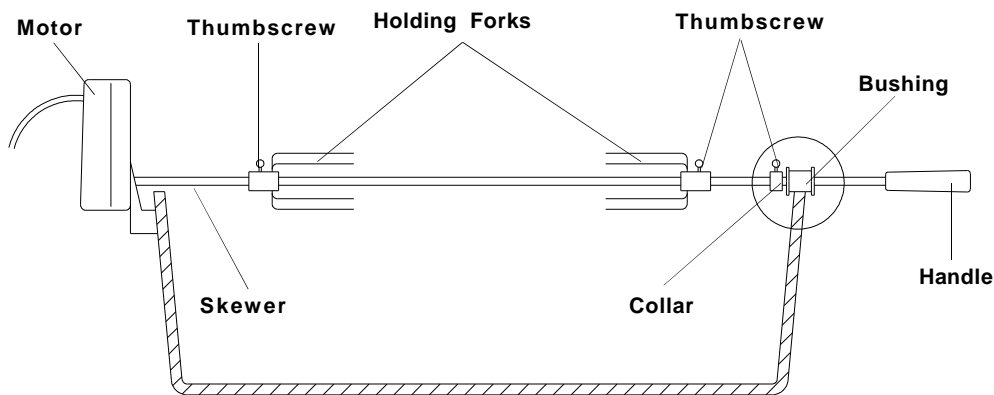

The bushing and collar must always be used with this rotisserie.

BEFORE rotisserie cooking You will need to remove the cooking grid (and possibly the flame tamers) on your grill to rotisserie cook - depending on the size of meat you will place on the rotisserie.

Using your Infrared Back Burner and Rotisserie

Your new grill includes an Infrared Back Burner and a Rotisserie designed to slowly cook foods that are moist and flavorful, because the turning food self bastes using infrared heat. The location of the Back Burner allows the placement of a basting pan beneath the food to collect juices and drippings for basting and gravy. To flavor the contents of the basting pan you may add herbs, onions, or other spices of your choice. The Rotisserie Burner is Infrared, which provides intense radiant heat. This intense heat is magnificent for searing in the natural juices and nutrients found in quality cuts of meat.

Rotisserie cooking is a slow cooking process and the maximum temperature you can expect to reach with the Lid closed is about 325 to 350° F.

IMPORTANT SAFEGUARDS

When using electrical appliances, basic safety precautions should always be used, including the following:

Read All Instructions:

1. Always attach the Rotisserie to the grill first, and then plug cord into a grounded outlet. To disconnect, turn Rotisserie "OFF" then remove plug from outlet.
2. Most grill surfaces and accessories are hot during and after cooking, so use reasonable care around grill, wear protective mitts and use the Rotisserie Handle.
3. The use of accessory attachments on the Rotisserie is not recommended by the manufacture and may cause injuries. Do not use this appliance for other than intended use.
4. Never line the bottom of your Grill Bowl with aluminum foil, sand or any grease absorbent substance.
5. Should a grease fire occur, turn the Burners and gas off and leave the Lid CLOSED until fire is out.
6. To protect against electrical shock, do not immerse electrical cord, plug or motor in water or expose to rain. Protect electrical elements from burners, hot grill surfaces and grease.
7. Do not operate rotisserie with a damaged cord or plug, or if the rotisserie malfunctions or has been damaged in any manner. Return rotisserie to the nearest authorized service facility for examination, repair, or adjustment.
8. Do not let children operate grill or rotisserie, and do not let children play nearby.
9. Unplug rotisserie from electrical outlet when not in use and before cleaning. Allow to cool before adding or removing parts.

10. When rotisserie cooking place a drip pan of some sort under the food to be cooked. This will capture the drippings and keep grill clean of excess grease which could cause a fire. Use caution when moving a drip pan containing hot oils.
11. The motor is set for 120VAC, 50/60 Hz current.
12. This rotisserie is for use outdoors only.

Back Burner Lighting Instructions

Note: The location of the Back Burner makes it more susceptible to winds that will decrease the performance of your Rotisserie cooking. For this reason you should not operate the Back Burner during windy weather conditions.

For best results, always Rotisserie cook with the grill Lid down and the Back Burner Control Knob set to High. Do not use the main grill Burners when the Back Burner is in operation.

1. Open the Grill Lid.
2. Set all Control Knobs to OFF and open the LP gas Tank Valve slowly until 1/4 to 1/2 open. For Natural Gas open Shutt Off Valve at source completely.
3. Push and turn the Back Burner Control Knob to IGN position. Push the Control Knob in to ignite the burner.
4. If the Burner does not light, turn the Control Knob to OFF, wait 5 minutes for gas to clear, then retry.
5. Once lit, the Back Burner will reach cooking temperature quickly. The orange/red glow will even out in about 5 minutes.
6. For best results, always Rotisserie cook with the grill Lid down and the Back Burner Control Knob set on HIGH. **Do not use the main Burners when the Back Burner is in operation.**

WARNING

The Rotisserie Motor must be electrically grounded in accordance with local codes or, in the absence of local codes, with the National Electric Code, ANSI/NFPA 70-1990. Keep the Rotisserie Motor electric cord away from the heated surface of the grill. Do not operate the Rotisserie with a damaged cord or plug, or if the Rotisserie malfunctions or has been damaged in any manner. Call the Grill Information Center for replacement. The power supply cord has a 3-prong grounded plug. For your personal safety do not remove the grounding prong. It must be plugged into a mating 3-prong grounding type receptacle, grounded in accordance with the National Electrical Codes and local codes and ordinances. If an extension cord is used it must be properly grounded and suitable for use with Outdoor Appliances. Keep the extension cord connection dry, off of the ground and out of the reach of children. When the Rotisserie Motor is not in use remove and store in a dry indoor area.

Cleaning and Maintenance

Keeping outdoor cooking gas appliance area clear and free from combustible materials, gasoline and other flammable vapors and liquids.

As with all appliances, proper care and maintenance will keep your grill in top operating condition and prolong its life. By following these cleaning procedures on a timely basis, your grill will stay clean and work properly with minimum effort.

CAUTION:

Be sure your grill is OFF and cool before cleaning.

Cleaning The Cooking Grids

Before initial use and as needed, wash your Grids with a mild detergent and rinse with hot water. For stubborn food residue use a degreaser and fiber or brass cleaning brush.

Cleaning The Grease Tray and Receptacle

To reduce the chance of fire, the Grease Draining Tray, Grease Receptacle and Heat Shield should be inspected before each grill use. Remove grease (a plastic spatula works well) and wash Grease Tray and Receptacle with a mild soap and warm water solution.

Cleaning the Flame Tamers

To reduce the chance of flare-ups, Flame Tamers should be cleaned whenever food or grease drippings accumulate. Brush off Flame Tamers with a fiber type brush and turn over to allow the burner heat to burn off any stubborn food residue. The Ceramic Flame Tamers work equally well on either side.

Annual Cleaning of The Grill Interior

Use a fiber or brass cleaning brush to clean the interior Grill Bowl, Cooking Grids, Flame Tamers and grease containers. On porcelain finished parts never use a wire brush or metal scraper which can scratch or chip the porcelain finish and promote rusting.

1. Turn all Control Knobs to the full OFF position.
2. Turn the LP gas Tank Valve to the full OFF position.
3. Detach the LP gas Regulator assembly from your gas grill or disconnect the Quick Disconnect Hose from the gas source.
4. Remove and clean the Flame Tamers, Cooking Grids, and Grill Burners.

5. Cover each gas Valve Orifice with aluminum foil.
6. Brush the inside and bottom of the grill with a brass wire brush or fiber cleaning pad, and wash with a mild soap and warm water solution. Rinse thoroughly and let dry.
7. Remove aluminum foil from Orifices and check each Orifice for obstruction.
8. Check each Spark Electrode, adjusting as needed. The space between the Spark Electrode Tip and Spark Receiver should be approximately 3/16".
9. Replace the Burners and adjust the gas collector box. The edge of the collector box should be overlapping the Burner Port.
10. Replace Flame Tamers and the Cooking Grids.
11. Reconnect the gas source and observe the Burner flame for correct operation.

Exterior Stainless Steel Surfaces:

Weathering and high heat can cause a stainless steel grill Lid to turn tan in color. This is not to be confused with rust and is not a product defect. Machine oils used in the manufacturing process of stainless steel as well as cooking oils and a dirty grill Lid can also encourage discoloration if the Lid is not cleaned prior to grill use.

1. Shut off gas supply at source and disconnect fuel line from Gas Valve Manifold. Protect fuel line fitting.
2. Use a Stainless Steel Cleaner and soft cloth to remove residual adhesive and oils from the inside and outside of your grill Lid. Never use abrasive cleaners or scrubbers. In addition to the initial cleaning, routine cleaning to remove dirt, grease and oils will help discourage Lid discoloration.

Grill Information Center: If you have questions about assembly or grill operation, or if there are damaged or missing parts when you unpack this unit from the shipping boxes, call us 8am - 4:30 pm CST, Monday through Friday at: **1-800-770-9769**

Cleaning The Burner Tubes and Burner Ports

To reduce the chance of "FLASH-BACK" you must clean the Burner Tubes at least once a month in late summer or early fall when spiders are most active or when your grill has not been used for an extended period of time.

1. Turn all Control Knobs to the full OFF position.
2. Turn the LP gas Tank Valve to the full OFF position.
3. Detach the LP gas Hose and Regulator Assembly from your gas grill or disconnect the Quick Disconnect Hose from the Natural Gas source.
4. Remove the Cooking Grids, Flame Tamers, and Grease Trays from your grill.
5. Remove the Cotter Pin from the rear underside of each Burner using a pair of long nose pliers.
6. Carefully lift each Burner up and away from the gas Valve Orifice.
7. Refer to **Figure 1** and perform one of these three cleaning methods:
 - Bend a stiff wire, (a lightweight coat hanger works well) into a small hook as shown below. Run the hook through the Burner Tube and inside the Burner several times to remove any debris.



- Use a Burner Cleaning Brush or a bottle brush with a flexible handle. Run the brush through the Burner Tube and inside the Burner several times, removing any debris.
- Use an air hose to force air through each Burner Tube. The forced air should pass debris or obstructions through the Burner and out the ports.

Regardless of which Burner cleaning procedure you use, we recommend you also complete the following steps to help prolong Burner life.

1. Use a wire brush to clean the entire outer surface of each Burner until free of food residue and dirt.
2. Clean any clogged ports with a stiff wire, such as an open paper clip.
3. Inspect each Burner for damage (cracks or holes) and if such damage is found, order and install a new Burner. After installation, check to insure that the Gas Valve Orifices are correctly placed inside the ends of the Burner Tubes. Also check the position of your Spark Electrode.

⚠ WARNING

The location of the Burner Tube with respect to the Orifice is vital for safe operation. Check to ensure the Orifice is inside of the Burner Tube before using your gas grill. See **Figure 2**. If the burner tube does not fit over the Valve Orifice, lighting the Burner may cause explosion and/or fire.

Figure 2

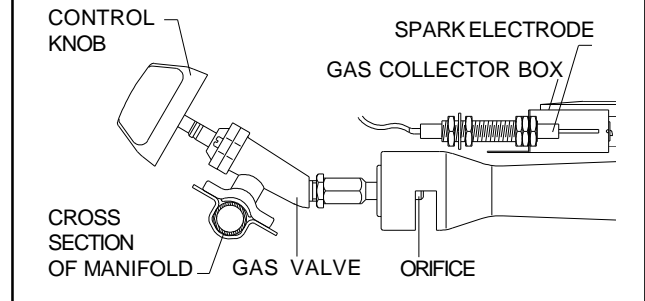
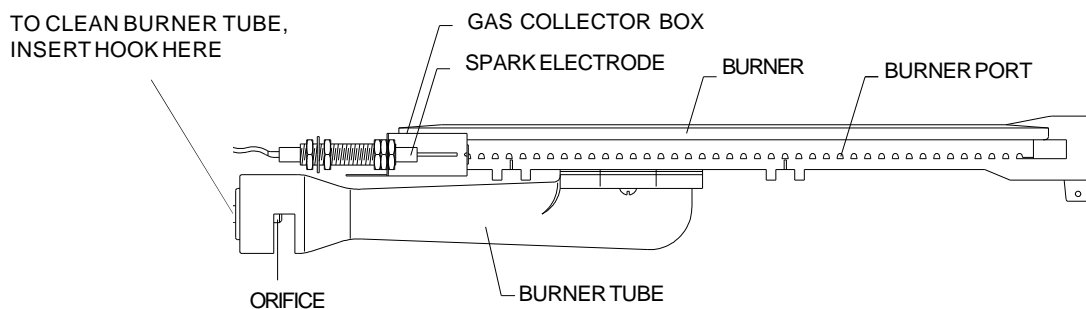

Figure 1



Frequently Asked Questions

Question: Can I convert my grill from LPG to NG?

Answer: No, your gas grill is manufactured to exact specifications and is certified for Liquid Propane (LPG) or Natural Gas (NG) use only. For your safety, conversion kits are not available. Any attempt to convert your grill will void your warranty.

Question: The Hose and Regulator supplied with my grill does not fit the older LPG tank I've used for years.

Answer: U.S. Government regulates gas appliances and LP gas tanks. When regulations are changed the LP gas tank fittings are altered to insure compliance. If your LP gas tank does not fit the Hose and Regulator supplied with your new grill, the tank is outdated and must be replaced. **Note:** Effective April 1, 2002 all LP gas tanks sold must include an "OPD" Overflow Protection Device. This internal device prevents the LP gas tank from being overfilled. Tanks without an OPD valve can not be refilled.

Question: Are the serial and model numbers of my grill listed somewhere for future reference?

Answer: The model and serial numbers are listed on a Silver Label placed on the Control Panel bottom right-hand side. If your grill features a Side Burner, it will have its own silver label and a model number ending in SB. This is not the primary grill model number or serial number needed for Product Warranty Registration or for Customer Support purposes.

Question: What causes grill parts to rust and what affect does it have on the grill materials.

Answer: Rusting is a natural oxidation process and may appear on cast-iron and steel parts. Rust will not affect short term performance of your grill. Stainless steel grill parts will not rust. However, weathering and extreme heat can cause a stainless steel Lid to turn tan color. This is discoloration and is not considered a manufacturing defect.

Question: My grill does not light properly. Why?

Answer: Always light the Burner farthest from the fuel source first. This draws gas across the Manifold helping prevent air pockets which obstruct gas flow. Also check these causes:

- Check LP gas supply. An empty LP gas tank weights about 20 pounds. A full tank weighs about 40 pounds.
- Check to insure all gas connections are secure.
- The Ignition AA battery may need replacing.
- Ignition wires may be loose. Remove the battery, inspect the Ignitor Junction Box found behind the Control Panel and connect any loose wires.
- Spark Electrode Tips may need repositioning. Refer to the "Electrode Check" procedures found on page 15.
- Check that the end of each Burner Tube is properly located over each Gas Valve Orifice.
- There may be an obstruction in the gas line. To correct this, remove LP gas Hose and Regulator or Natural Gas fuel line from your grill. Do not smoke! Open gas supply for one second to clear any obstruction from fuel line. Close off gas supply at source and reconnect fuel line to your grill.
- If an obstruction is suspected in the Orifice or Gas Valves, call the Grill Information Center, at 1-800-770-9769.

Question: My grill has a low flame and sometimes will not light. Why?

Answer: You need to purge air from the gas line or reset the Regulator excess gas flow device. Opening the tank valve all the way or too quickly triggers the Regulators safety device to shut down gas flow which prevents excessive gas flow to your grill. Lighting the Burner farthest from the fuel source every time will help eliminate air pockets in the Manifold. Perform this procedure every time a new LP tank is connected to grill:

- Turn all Control Knobs to the OFF position.
- Turn off the LP gas tank valve.
- Disconnect Regulator from LP gas tank.
- Let unit stand for 5 minutes.
- Reconnect Regulator to the LP gas tank.
- Open Grill Lid or Side Burner Lid. Turn the tank valve on slowly until 1/4 to 1/2 open.
- Light the Burner farthest from fuel source by turning its Control Knob to IGN then pushing in the Control Knob. To light the Side Burner push its Control Knob in and turn to HIGH.

Question: Sometimes I hear a humming sound coming from my Regulator. What causes this?

Answer: The humming sound is gas flowing through the Regulator. A low volume of sound is normal and will not interfere with the operation of your grill. If the humming sound is loud and excessive you need to purge air from the gas line or reset the Regulator excess gas flow device as described above.

Question: How and when do I clean the interior cooking components of my grill?

Stainless Steel Cooking Grids: Before initial use and as needed, wash Grids with a mild detergent and rinse with hot water. For stubborn food residue use a degreaser and fiber or brass cleaning brush.

Flame Tamers: To reduce the chance of flare-ups, Flame Tamers should be cleaned whenever food or grease drippings accumulate. Brush off Flame Tamers with a fiber type brush and turn over to allow the burner heat to burn off any stubborn food residue. The Ceramic Flame Tamers work equally well on either side.

Grease Tray, Receptacle and Heat Shield:

To reduce the chance of fire, the Grease Draining Tray, Grease Receptacle and Heat Shield should be inspected before each grill use. Remove grease (a plastic spatula works well) and wash Grease Tray and Receptacle with a mild soap and warm water solution.

Question: What causes a stainless steel to discolor?

Answer: Weathering and high heat can cause a stainless steel grill Lid to turn tan in color. This is not to be confused with rust and is not a product defect. Machine oils used in the manufacturing process of stainless steel, cooking oils and a dirty grill Lid can also encourage discoloration if the Lid is not cleaned prior to grill use. After your grill is assembled, remove the protective PVC film from the grill Lid and use a Stainless Steel Cleaner and soft cloth to remove residual adhesive and oils from the inside and outside of your grill Lid. Never use abrasive cleaners or scrubbers. Routine cleaning to remove dirt, grease and oils will help discourage Lid discoloration.

Cooking Instructions

WARNING

Your grill will get very hot. Never lean over the cooking area while using your grill. Do not touch cooking surfaces, grill housing, Grill Lid or any other grill parts while the grill is in operation, or until the grill has cooled down after use.

Failure to comply with these instructions may result in serious bodily injury.

Burn-off

Before cooking on your gas grill for the first time, you will want to "burn off" the grill to eliminate any odor or foreign matter. Just ignite the Burners, lower the Lid, and operate grill on the HIGH setting for three to five minutes.

CAUTION:

Operating your grill on the HIGH setting for longer than five minutes may damage certain parts of your grill. **Do not leave your grill unattended.**

Preheating

To preheat, light your grill on HIGH, lower the lid and follow this timetable:

- For high temperature cooking, preheat grill 3 to 5 minutes.
- For low temperature cooking, preheat grill 3 minutes.
- To slow cook, preheating is not necessary.

Cooking Temperatures

High setting: Only use this setting for fast warm-up, searing steaks or chops and for burning food residue off the grill after cooking is complete. **Never** use the HIGH setting for extended cooking.

Medium to Low settings: Most recipes specify medium to low settings, including all smoking, roasting, baking and for cooking lean cuts such as fish.

NOTE: Temperature settings will vary with the amount of wind and temperature outside your home.

Direct Cooking

The direct cooking method can be used with the supplied Cooking Grids and food placed directly over the lit grill Burners. **Direct cooking requires the grill lid to be up.** This method is ideal for searing and whenever you want meat, poultry or fish to have an open-flame barbecued taste. Deep frying and smoking are also best cooked in this manner because they require direct heat.

Indirect Cooking

The indirect cooking method can also be used with the supplied cooking grids. To cook **indirectly**, the food should be placed on the left or right side of your grill with the burner lit on the opposite side. **Indirect cooking must be done with the lid down.**

Flare-Ups

The fats and juices dripping from grilled food can cause flare-ups. Since flare-ups impart a favorably, distinctive taste and color to food cooked over an open flame, they should be accepted up to a point. Nevertheless, uncontrolled flaring can result in a ruined meal.

WARNING

Do not line the bottom of the grill housing with aluminum foil, sand or any substance that will restrict the flow of grease into the grease draining tray and receptacle.

Failure to comply with these instructions could result in a fire or explosion which could cause serious bodily injury, death, or property damage.

Guide to Grilling Meat and Poultry with the Direct Cooking Method

Grilling Steak and Ribs

Turn the grill Burners on high, close the Lid and preheat your grill 3 to 5 minutes. Open Lid and place the meat on the Cooking Grid directly above the lit Burners. Cook the meat on both sides until seared. Reduce the heat to medium and cook meat until done. Grilling times will vary according to meat thickness.

Grilling Hamburgers and Sausages

Turn the grill Burners on high, close Lid and preheat your grill 3 to 5 minutes. Open Lid and place the meat on the Cooking Grid directly above the lit Burners. Cook the meat on both sides until seared. Reduce the heat to medium and cook the meat until done. Grilling times will vary according to meat thickness.

Grilling Poultry

Turn the grill Burners on high, close Lid and preheat your grill 2 to 3 minutes. Then raise the Lid, reduce heat to medium and cook poultry directly over lit Burners until done. Poultry skin is fatty so you should expect some flare-ups when using this direct method.

To minimize flare-ups, try grilling poultry using the indirect method. Place the poultry on one side of the grill with the opposing Burners on medium heat, and lower the grill Lid. Grilling times will vary based on the size of your poultry.

Grilling Pork

Turn Burners on high and preheat your grill 3 to 5 minutes with the Lid down. Raise Lid, place pork on Cooking Grid and cook until seared. Reduce heat to medium and cook until done. Grilling times will vary according to meat thickness.

Cut of Meat

T-bone steak
Sirloin steak
Beef spare ribs
Porter house steak
New York strip steak

Hamburgers
Sausages

Chicken breast
(cook with bone down)
Chicken wings
Drumsticks

Whole bird
(cook with breast up)

Pork spare ribs
Chops
Loins
Cutlets

Approximate Cooking Times

Rare: 4-8 minutes
Medium: 10-14 minutes
Well done: 15-20 minutes

Rare: 4-6 minutes
Medium: 8-10 minutes
Well done: 10-15 minutes

Direct method:
approximately 15 minutes

Indirect method:
up to 30 minutes

Indirect method:
approximately 1 hour

Rare: 4-8 minutes
Medium: 10-14 minutes
Well done: 15-20 minutes

Guide to Grilling Fish and Seafood with the Direct Cooking Method

Whole Fish and Whole Fillets

Preheat your grill on HIGH for 2-3 minutes with the Lid down. Raise Lid and turn Burners to medium heat. Place fish (skin down) on grill and cook over direct heat until done. Use cooking time as a guide or until fish is opaque but still moist.

Cut of Meat

Whole fish
Whole fish fillets

Approximate Cooking Times

10 - 12 minutes per pound or until fish is opaque

Smaller Fish Fillets and Cubes

Follow the directions from above, using approximate cooking times shown at right. Place a small piece of aluminum foil on the Cooking Grids if the fish pieces are small enough to drop between the cooking grids.

Fish fillets
Boneless cubes

4 - 5 minutes each side or until fish is opaque

Guide to Grilling Vegetables and Fruit

Prepare your fruit or vegetables and brush with butter or basting sauce if desired. To cook **indirectly**, the food should be placed on the left or right side of your grill with the Burner lit on the opposite side and the grill Lid down.

In some instances, you may want to grill vegetables and fruit **directly** over the heat, using the supplied Cooking Grids. Foods that work best with direct heat are relatively soft and require a short cooking time; mushrooms, zucchini, tomatoes and skewered fruit such as apricots, peaches, pineapple, strawberries and kiwis. Remember the **grill Lid must remain up when cooking directly**.

For very firm vegetables—particularly potatoes and yams, we recommend that you partially boil until almost cooked, before placing them on the grill. Cooking times using the **indirect method** with the hood down will be similar to those for your kitchen

oven. However, there are many factors such as outside temperature, wind conditions and location of grill that affect your grill performance so we suggest you watch the Temperature Gauge and adjust the heat accordingly.

Cooking times for foods prepared with the **direct method** will be much shorter mainly because of the direct heat source and softness of the food. Timing will be comparable to normal pan frying or grilling.

Guide to Slow Roasting and Baking Techniques

An Important Note About Heat Settings

The suggested heat settings shown are approximate. There are many factors such as outside temperature, wind conditions and grill location that affect your grill performance. We offer these cooking times as a convenience, but suggest you watch the grill Temperature Gauge and adjust the heat accordingly.

Preparing to Roast

Roasting uses the **indirect cooking** method. Therefore, the food should be placed on the left or right side of your grill with the Burner lit on the opposite side. You can also use the supplied Cooking Grid with an aluminum drip pan underneath allowing you to collect juices for making gravies. Remember, indirect cooking requires the Lid of your grill to be down.

Preheating your grill is not required for slow cooking methods such as roasting. If you do choose to preheat your grill before roasting, turn the Burners on high and close Lid for approximately 2-3 minutes.

Food Preparation

Trim meat of excess fat. Truss meat and poultry with cooking string to retain shape if desired. Bacon strips can be used to cover the outside surface of lean meat and poultry to help prevent it from drying out. Another method for keeping food moist during roasting is to put water in a cooking pan, then cover with foil. The foil should be removed for the first or the last part of the cooking time to ensure proper browning.

Tips for Roasting

Except when roasting with water in a roasting pan, the juices that collect in the pan can be used as the base for a tasty sauce or gravy. Place a cooking pan directly over the heat, add extra butter if needed, then add several spoonfuls of flour to thicken sauce. Finally, add sufficient chicken or beef stock to obtain the desired consistency.

Once the meat is cooked, remove it from your grill and cover with a piece of foil. Allow it to stand for 10-15 minutes which allows the juices to settle. This will make carving easier and ensure a tender, juicy roast.

Type of Food	How Cooked	Approximate Cooking Times
Beef	Rare	18 minutes per pound
	Medium	23 minutes per pound
	Well done	27 minutes per pound
Lamb	Medium	18 minutes per pound
	Well done	23 minutes per pound
Veal		27 minutes per pound
Pork		30-33 minutes per pound
Chicken		20-25 minutes per pound
Duck		25 minutes per pound
Fish		10 minutes per pound
Turkey, under 16 pounds		20-25 per pound + 30 minutes
Turkey, over 16 pounds		18-23 per pound + 15 minutes

BAKING TECHNIQUES

From casseroles and cornbread to delicious deserts like fondue fruit skewers or crumb cake, baking on the grill is as easy as baking in the kitchen.

Preparing to Bake

To bake in your new grill you'll need a baking dish or cast-iron cooking pan, and a pair of insulated cooking mitts. If the cooking pan is cast-iron be sure to season the pan before use.

Preheat your grill 3-5 minutes, then lower heat to achieve the baking temperature desired. Baking uses the

indirect cooking method. Therefore, your cooking pan should be placed on the left or right side of your grill with the Burner lit on the opposite side.

Tips for Baking

Prepare your favorite recipe as you would in the kitchen. Foods cooked in the grill for long periods of time should always be covered in aluminum foil to retain moisture. You will need to stir the food several times as it bakes, and add additional liquid if required.

Watch the temperature, and adjust to cook according to your recipe directions.

Oven Temperature

Slow	300° - 340° F
Moderate	355° - 390° F
High	410° - 480° F

Recommended Grill Setting

Both outside Burners on low
One outside Burner on high and the other outside Burner on low
Both outside Burners on high

Guide to Rotisserie Cooking

Rotisserie Cooking

Rotisserie cooking produces foods that are moist, flavorful and attractive. The Rotisserie system is most commonly used for cooking meat or poultry and is designed to cook food slowly. You can place a cooking pan beneath the food to collect juices for basting and gravy. To flavor the contents of the cooking pan you may add herbs, onions, or other spices of your choice.

Rotisserie cooking is a slow cooking process and the maximum temperature you can expect to reach with the Lid closed is about 325 to 350° F.

Balancing the Food

In Rotisserie cooking, balancing the food is of utmost importance. The Rotisserie must turn evenly or the stopping and starting action will cause the food to cook unevenly and possibly burn the heavier side.

The easiest foods to balance are those of uniform shape and texture. To test if the food is balanced correctly when secured, place the ends of the Rotisserie Skewer loosely in the palms of your hands. If there is no tendency to roll, give the Skewer a quarter turn. If it is still stable, give it a final quarter turn. It should rest without turning in each of these positions. It can then be attached to your grill.

Loading the Rotisserie

To load the Skewer begin with the Handle in place, and slide one of the Meat Holders (Prongs facing away from the Handle) onto the Skewer. Push the Skewer through the center of the food, and then slide the second Meat Holder, (prongs toward the food) onto the Skewer. It is very important to center and balance the food to be cooked on the Skewer then push the Meat Holders firmly together. Tighten the Wing Nuts with pliers. It may also be necessary to wrap the food with butcher string (never use plastic or nylon string) to secure any loose portions. Once the food is secure insert the Skewer into the motor. If needed, remove the grill Cooking Grids. Place a basting pan below the food to collect the juices and drippings as the food cooks. It is normal for the Skewer to flex when larger cuts of meats are being cooked. Start motor and cook food with the Lid closed.

Guide to Smoking

Preparing to Smoke

Smoking gives food a distinctive, delicious flavor. You will find a variety of wood chips or pellets available for use in smoking grilled foods. Pre-soaking of wood chips may be required so read and follow the manufacturers instructions for preparation of smoking chips prior to use.

Note: it is our experience that many smoking chip and pellet products do not actually produce a smoke but instead infuses the food with flavor. Please read product labels carefully and if in doubt, ask your retailer for details.

Using A Smoker Box

There are many optional smoker boxes available for purchase. Follow these guidelines and always refer to the label of your smoking chips or pellets for specific directions.

Raise your Grill Lid and light the grill. Lower the Grill Lid allowing your grill to reach the desired cooking temperature for the food you are grilling. Fill your smoker box with your prepared smoking chips or pellets. Dried herbs and spices may also be added to produce different flavors. Wear an insulated cooking glove and place your smoker box on a Cooking Grid or Flame Tamer directly above a lit grill Burner. The heated smoking chips or pellets will flavor your foods.

Tips for Smoking

You can reduce the strength of the smoke flavor by only smoking for half or three quarters of the cooking time. The heat required for smoking is normally low to medium.

Foods naturally high in oils lend themselves well to smoking, while drier foods benefit from a marinade. You can also rub the food with herbs, spices or flavored oils. Many foods can be smoked to produce stunning results with very little effort. Here are a few suggestions:

- **Tuna steaks**, marinated in Asian flavors of sesame oil, soy sauce and sherry.
- **Pork filets**, rubbed with ginger, orange rind and brushed with maple syrup.
- **Mussels**, brushed with lemon rind and chili oil.
- **Lamb cutlets**, marinated in virgin olive oil, lemon, oregano and black pepper. The same marinade can be used for a whole leg or rack of lamb.
- **Chicken**, boneless chicken pieces—especially sliced breasts.
- **Fish**, sliced fillets of firm fish, assorted seafood such as prawns, scallops and calamari.
- **Pork**, sliced filets, diced or minced pork, sliced leg steak and sliced chops.
- **Beef**, sliced fillet, rib-eye, round, rump and sirloin.
- **Lamb**, sliced fillet, round and loin.

Guide to Stir-Frying and Deep-Frying

STIR-FRYING TECHNIQUES

This method of cooking is popular around the world and can be easily accomplished outdoors on your grill. It's a quick and healthful way of preparing a complete meal using meat, poultry or seafood in infinite combinations with other interesting ingredients like vegetables, rice or noodles.

Preparing to Stir-fry

Although it is possible to stir fry in other dishes, a wok is your best tool. Its high sides enable the cook to stir food without spillage. Its construction allows you to cook quickly at high temperatures, with instant control of heat which is essential for successful stir frying.

Food preparation

Slice meat and poultry into long thin strips and cube fish fillets. Remove all fat from meat and poultry and cut large vegetables into even slices or cubes.

Marinate foods for extra flavor and tenderness. Marinating times will vary for red meat, fish and or various cuts. Less tender cuts of meat should be marinated longer. Remember to always chill marinating food in the refrigerator prior to cooking.

Stir-fry meats, poultry or fish first. Next, add hard vegetables like carrots. Then continue with softer vegetables like snowpeas and peppers. To ensure even cooking, continually stir and toss the food in the wok using a wooden spoon or spatula.

Tips for Stir-frying

Place a wok directly over a high heat on your grill or Side Burner. Add only a small amount of food at a time to ensure fast cooking and also to allow the wok to reheat between ingredients.

DEEP-FRYING TECHNIQUES

A wide variety of foods can be deep-fried outdoors on your grill, from potatoes, to seafood and chicken. Deep-frying uses a large portion of oil, preferably saturated. The outdoor location is ideal for deep-frying as smoke, grease and smells reach for the sky, not the ceiling of your kitchen.

Preparing to Deep-fry

Deep-fry on your grill using a cooking pan or wok, over direct heat with the grill lid raised.

Fill a cooking pan no more than half full of vegetable or corn oil. Start with low heat, then raise the heat gradually. Check the temperature of the oil carefully with a frying thermometer or test with a cube of bread. The cube of bread should brown in about 30 seconds for most cooking needs. A temperature between 350 and 400 degrees is optimal for preparing the majority of deep-fried foods.

Food Preparation

Foods being deep-fried taste better when coated with either batter or breadcrumbs to add flavor and prevent moisture from escaping.

Tips for Deep-frying

Wear an insulated cooking glove and slowly lower foods into the hot oil using a wire scoop or stainless steel tongs. Add only a small quantity of food to the oil, allow it to cook, then repeat with another small quantity. This ensures the oil doesn't drop in temperature. Once the food is cooked, remove it carefully and drain onto a paper towel. Turn the heat off as soon as you have finished deep-frying and allow your pan to cool. When the oil is cool, remove all remnants of fried foods by straining it through a fine metal sieve. Once the oil is quite cool, store it in a clean bottle for future use.

Guide to Using the Optional Secondary Cooking Rack

Vegetables are generally easy to cook on the grill. The optional cooking rack makes it convenient because you can still use the main cooking area while the vegetables are suspended above the Cooking Grids.

Pre-cook hard vegetables by briefly boiling or microwaving them before cooking on the grill. Wrap vegetables in a double thickness of foil to protect them while cooking on the grill. Then, remove the foil if desired, 10-15 minutes before the end of cooking, brush vegetables with butter or oil and finish cooking.

The optional cooking rack can be used for purposes other than just the obvious. Consider using it for warming French bread, garlic bread, croissants or even bagels.

A small whole fish wrapped in foil also cooks well on the optional cooking rack. Parcels of seafood such as scallops, prawns and sliced fish fillets prepared in a sauce and portioned into small foil wraps cook well this way, too.

Recipes

ONION BURGERS

A honey and mustard sauce glazes the onion slices as they cook alongside these delicious burgers. For optimal sweetness, select Vidalia or Walla Walla onions. **Makes 4 open face burgers.**

Ingredients

- 2 large sweet onions, sliced (12 to 16 ounces)
- 2 tablespoons margarine or melted butter
- 2 teaspoons dry mustard
- 2 teaspoons honey
- 1 pound lean ground beef
- 1/4 teaspoon salt
- 1/8 teaspoon pepper
- 4 slices Texas toast
- 4 lettuce leaves
- 4 tomato slices

Preparing Onions

Place onions in a cooking pan or on a small piece of aluminum foil. Combine melted margarine, mustard and honey, then drizzle over onions. Cover pan with lid or fold up edges of foil and seal with double fold to completely enclose onions—leaving space for steam to build. Place pan or foil packet on grill directly over medium heat for 15 minutes with the grill lid up.

Preparing Burgers

While onions are cooking, combine ground beef, salt and pepper in a medium bowl and mix well. Shape mixture into four 3/4 inch burger patties and add to grill, directly over heat. Grill burgers along with onions for about 5 minutes, then turn burgers. Grill for 8 to 10 minutes more or until no pink remains in meat, and onions are tender. To serve, toast both sides of Texas toast on grill. Then top each slice of Texas toast with a burger, lettuce, tomato and onion. Sprinkle with pepper if desired.

DOUBLE SALSA BURGERS

A fresh tomato salsa flavors the beef mixture for a zesty tasting burger. The salsa also serves as a colorful topping. **Makes 6 burger patties.**

Ingredients

- 1 large tomato, seeded and finely chopped
- 1/2 cup finely chopped green pepper
- 1/4 cup finely chopped red onion
- 2 finely chopped, seeded jalapeno peppers
- 1 garlic clove, minced
- 1 tablespoon snipped cilantro

- 1/4 teaspoon salt
- 1 1/2 pounds lean ground beef
- 2 cups shredded lettuce
- 1/3 cup finely shredded cheddar cheese
- 1/4 cup dairy sour cream and /or guacamole

Preparing the Salsa

Combine tomato, green pepper, onion, jalapeno peppers, garlic, cilantro and salt in a bowl. Set aside 2 tablespoons of salsa. Cover and chill remaining salsa until serving time.

Preparing Burgers

In another bowl, combine ground beef with 2 tablespoons of reserved salsa, mix well. Shape mixture into six 1/2 inch thick burgers and place on the grill directly over medium heat with lid up. Grill for 13 to 15 minutes or until no pink remains. Turn burgers once, halfway through grilling time. Arrange the shredded lettuce on individual plates. Top lettuce with a burger, cheddar cheese and salsa. Serve with sour cream and/or guacamole.

CHICAGO STYLE HOT DOGS

Serve these hot dogs "Chicago-style" with pickled peppers! **Makes 4 servings.**

Ingredients

- 1/3 cup ketchup
- 1/4 cup chopped pickled peppers
- 2 tablespoons pickle relish
- 2 tablespoons chopped onion
- 1/4 teaspoon poppy seed
- 4 fully cooked 4-ounce jumbo hot dogs
- 4 hot dog buns

Preparing the Relish

Combine ketchup, chopped pickled peppers, relish, onion and poppy seed in a small bowl, then set aside.

Preparing Hot Dogs

Place hot dogs on grill directly over medium heat 5 to 8 minutes with the lid up. Turn hot dogs and brush with some of the relish mixture. Grill hot dogs 6 to 8 minutes more or until thoroughly cooked.

To Serve

Toast inner sides of hot dog buns on grill. Serve hot dogs inside buns and top with remaining relish mixture.

RIB EYE STEAKS WITH GRILLED GARLIC

As they cook, the garlic cloves mellow in flavor, making a delicious sauce for any grilled meat. And for an appetizer, spread the softened cloves over toasted slices of french bread! **Makes 4 servings.**

Ingredients

- 1 whole head of garlic
- 2 tablespoons olive oil or cooking oil
- 1 tablespoon snipped fresh basil, or 1/2 teaspoon dried basil, crushed
- 1 tablespoon snipped fresh rosemary or 1/2 teaspoon dried rosemary, crushed
- 2 twelve-oz. boneless rib eye steaks

Preparing the Garlic

Use a cooking pan or tear off a 24x18-inch piece of aluminum foil and fold long length in half, then trim to make a 12-inch square. Remove the outer layer of garlic head, then cut off and discard the top 1/2-inch of garlic head to expose the garlic cloves. Place garlic head in center of a cooking pan or in center of foil with all sides of the foil folded up around the garlic to form a cup. Drizzle garlic with oil and sprinkle with basil and rosemary. Cover pan or twist the ends of the foil to completely enclose the garlic.

Preparing Steaks

Place steaks and the garlic pack on grill directly over medium heat and cook about 7 minutes with the lid up. Turn steaks and grill for 5 to 8 minutes more, or until cooked to taste. Then remove steaks and place on platter. Remove garlic and drizzle its juices over your steak. Remove the softened garlic cloves and spread over your steak. Season with salt and pepper as desired and cut into serving-size pieces.

HERB-PEPPER SIRLOIN STEAK

The hearty beef flavor is complemented with a delicious herb coating! **Makes 6 servings.**

Ingredients

- 2 tablespoons ketchup
- 1/2 teaspoon coarsely ground pepper
- 1 1/2 teaspoons snipped fresh rosemary or 1/2 teaspoon dried rosemary, crushed
- 1 1/2 teaspoons snipped fresh basil or 1/2 teaspoon dried basil, crushed
- 1/8 teaspoon garlic powder
- 1 1 1/2-pound boneless beef sirloin steak, cut 1-inch thick

Preparation

Combine ketchup, pepper, rosemary, basil and garlic powder. Coat both sides of steak with mixture. Grill steak with lid up, directly over medium heat for 6 minutes. Turn steak and grill for 8 to 12 minutes more or until cooked as desired. Cut into serving size pieces.

BARBECUED RIBS

Serve this tangy barbecue classic with corn-on-the-cob, green salad, potato salad or coleslaw! **Makes 4 servings.**

Ingredients

- 2 pounds American style pork spareribs
- 1/2 cup barbecue sauce
- 1/2 cup tomato sauce
- 2 cloves garlic, crushed
- juice of 1 lemon
- few drops of tobasco sauce

Preparation

Place ribs into a large glass or ceramic dish. Combine remaining ingredients and pour over the ribs. Refrigerate for several hours.

Preheat your grill 3 minutes and place the ribs on cooking grid. Cook indirectly, over a low to medium heat until cooked. During the last few minutes of cooking you can cook the ribs over a direct fire for added barbecue flavor and texture.

MARINATED TUNA STEAK

Experiment with unique dishes, like this tuna steak recipe boasting a delicious wine marinade!

Makes 4 servings.

Ingredients

- 4 6-ounce fresh or frozen tuna steaks cut 1 inch thick. Thaw fish if frozen
- 1/3 cup dry white wine
- 1 tablespoon lemon juice
- 1 tablespoon olive oil or cooking oil
- 1 clove garlic, minced
- 2 teaspoons snipped fresh rosemary, crushed, or 1/2 teaspoon dried rosemary, crushed
- 1 teaspoon snipped fresh oregano, crushed, or 1/4 teaspoon dried oregano, crushed
- 1/4 teaspoon salt

Preparation

Combine wine, oil, garlic, rosemary, oregano and salt. Place tuna steak in plastic bag and into shallow dish, add marinade then seal bag. Rotate bag to coat fish well then chill for up to 2 hours, turning fish once.

Remove fish from bag and discard marinade. Place a cooking pan with baking rack or roasting rack into center of grill with outer burners on medium heat. Cook tuna steak on top of rack with lid down for 8 to 12 minutes or until fish begins to flake easily. Turn fish once during cooking. When cooked, remove fish from grill and serve.

MUSTARD-GLAZED HALIBUT STEAKS

A simple sauce of melted margarine, lemon juice, Dijon-style mustard and basil adds a scintillating note to these sizzling fish steaks! **Makes 4 servings.**

Ingredients

- 4 6-ounce fresh or frozen halibut steaks, cut 1 inch thick
- 2 tablespoons margarine or butter
- 2 tablespoons lemon juice
- 1 tablespoon Dijon-style mustard
- 2 teaspoons snipped fresh basil or 1/2 teaspoons dried basil, crushed

Preparation

Combine thawed fish, margarine or butter, lemon juice, mustard and basil into a cooking pan or aluminum foil rectangle, and cook directly over low flame until melted. Brush mixture over both sides of halibut fish steaks. Pour balance of mixture into small bowl.

Place clean cooking pan or foil on center of grill with both outer burners on medium. Place fish on grill and close lid. Cook indirectly for 8 to 12 minutes or just until fish begins to flake easily, turning once and brushing as needed with remaining mixture.

ALMOND COATED TROUT

This delicious recipe is unique and easy to prepare on your gas grill. **Makes 4 servings.**

Ingredients

- 2 trout
- 1/2 cup all purpose flour
- 1 egg, lightly beaten
- 1 cup sliced almonds
- 1/3 cup parmesan cheese, grated
- olive or peanut oil for frying

Preparation

Remove the head and tail from trout and fillet all bones. Cut each fish in half to form 4 long fillets. Coat fish in flour, dip in egg and roll in almonds. Refrigerate for 1 hour.

Fill a cooking pan with 1 to 2 inches of oil, and place over high heat. Cook trout until golden brown. Drain oil, sprinkle trout with parmesan cheese and serve right from the grill.

SOUTHWEST CHICKEN BREASTS

This popular recipe can also be a grilled chicken salad! Slice chicken into small strips and place them on top of shredded lettuce with avocado dressing and top with cheese! **Makes 6 servings.**

Ingredients

- 1/4 cup dry white wine
- 2 tablespoons olive oil or cooking oil
- 2 teaspoons snipped fresh tarragon or 1/4 teaspoon dried tarragon, crushed
- 1/4 teaspoon salt
- 6 skinless, boneless chicken breast halves
- 2 avocados, pitted, peeled and chopped
- 1 tomato, chopped
- 1 clove garlic, minced
- 2 tablespoons finely chopped seeded green chili peppers of your choice
- 2 green onions, finely chopped
- 1 tablespoon snipped fresh cilantro
- 1 tablespoon honey
- 1 tablespoon lemon juice

Preparing the Chicken

Combine wine, oil, tarragon and salt. Rinse chicken and dry with paper towels. Place chicken in plastic bag and into shallow dish—then add marinade and seal bag. Rotate chicken to coat well and chill up to 24 hours, turning bag occasionally.

Preparing the Avocado Dressing

Combine avocados, tomato, garlic, chili peppers, onions, cilantro, honey and lemon juice. Toss well then cover and chill up to 2 hours.

Grilling the Chicken

Remove the chicken from plastic bag and reserve the marinade. Grill chicken directly over medium heat with lid up for 5 minutes. Turn chicken and brush with marinade, then grill for 5-10 minutes more or until chicken is no longer pink. Serve with side of avocado dressing.

BARBECUED CHICKEN

Another backyard favorite, this recipe includes an easy to make, sweet and spicy sauce.

Makes 4 servings.

Ingredients

- 1/2 cup ketchup
- 1/4 cup orange marmalade
- 1 tablespoon vinegar
- 1/2 teaspoon celery seed
- 1/2 teaspoon chili powder
- 1/4 to 1/2 teaspoon bottled hot pepper sauce
- 1 2 1/2 to 3 pound broiler-fryer chicken, pre-cut

Preparing the Sauce

Combine ketchup, marmalade, vinegar, celery seed, chili powder and hot pepper sauce in a cooking pan, and cook directly over a low to medium heat. Leave the cooked sauce in the pan and remove from heat until chicken is prepared.

Preparing the Chicken

Wash chicken and dry with paper towels. Turn outside burners on medium and place pre-cut chicken pieces (bone side down) in center of grill. Close lid and cook indirectly for 1 hour or until chicken is no longer pink. Brush occasionally with sauce. Remove chicken from grill once cooked, then place cooking pan with sauce into center of grill and reheat. Pour warmed sauce over chicken and serve.

TRADITIONAL HOLIDAY TURKEY

Imagine everyone's surprise when you serve your next holiday turkey—complete with dressing—delicious and tender straight from the grill! **Serves 8 - 10**

Ingredients for Turkey

- 8 - 10 pound whole turkey
- 4 ounces butter, softened
- 2 tablespoons chopped thyme
- 2 tablespoons lemon juice
- 2 teaspoons grated lemon rind

Ingredients for Dressing

- 2 ounces butter
- 2 onions, finely chopped
- 8 ounces bacon, chopped
- 2 tablespoons port wine
- 1/4 cup red wine
- 2 chicken stock cubes
- 4 ounces chopped cashews, hazelnuts or pecans
- 1/2 cup chopped celery
- 1/2 cup chopped carrot
- 1 - 1 1/2 cups fresh white breadcrumbs
- 1 egg, lightly beaten
- salt and pepper to taste

Preparing the Dressing

Prepare dressing in a cooking pan directly over medium heat. Melt butter, add onions and bacon then saute 3 minutes. Add port, red wine and stock cubes and bring to a boil. Cook 2 minutes. Wear protective gloves and remove pan to allow ingredients to cool. Add remaining ingredients and mix.

Preparing the Turkey

Although not required, you may want to preheat your grill 3 minutes.

Wash inside of turkey and dry with paper towels. Pack breadcrumb seasoning into the turkey cavity. Combine the butter, thyme, lemon juice and rind together in a bowl. Using turkey baster, insert butter mixture under skin covering the turkey breast.

Truss the turkey with string and place it on a baking pan or roasting rack that rests into a cooking pan. Remove the cooking grids from your grill if necessary, then place the cooking pan and turkey in the center of your grill. Turn one outside burner to low, the other to medium, and close lid. Cook indirectly for 3 1/2 to 4 hours or until cooked. Halfway through cooking time you may alternate burner temperatures so that the turkey browns evenly. Once cooked, remove dressing from cooked turkey, slice and serve.

PIZZA ON THE GRILL

You may never want to call out for pizza again! Follow this pizza dough recipe, or purchase ready-made pizza dough found in your grocers refrigerated section—next to the biscuits. Slice and serve directly from the grill. **Serves 6 - 8**

Ingredients

- 1 1/2 teaspoons dried yeast
- 1 cup lukewarm water
- 1/2 teaspoon sugar
- 3 tablespoons olive oil
- 3 cups all purpose flour
- 1/4 cup tomato paste or Italian tomato sauce
- 6 ounces sliced pepperoni
- 1 red pepper, roasted and sliced
- 3/4 cup pitted black olives
- 8 ounces grated mozzarella cheese

It's easy to customize this recipe with toppings to suit your family's taste. For spicier crust, lightly rub the dough with olive oil then spice with pepper and garlic salt before spreading your tomato sauce.

Preparing the Pizza Dough

Combine yeast, water and sugar together and let stand in a warm place until mixture starts to foam. Add this yeast mixture to flour and oil and combine to form your pizza dough. Knead on a lightly floured surface until smooth and elastic. Cover and stand in a warm place until doubled in size. Knock back dough and roll out to a rectangle the size of your cooking pan or baking dish. Place dough into a lightly oiled pan.

If you purchased a ready-made pizza dough, simply open can and roll dough into a lightly oiled cooking pan.

Preparing the Pizza

Spread tomato paste or Italian tomato sauce on top of your pizza dough. Top with pepperoni, red peppers, olives, and lastly, mozzarella cheese. Or if you prefer, you may place cheese first with toppings on last.

Place a cooking pan in center of grill and cook indirectly, with one outside burner on high and the other on low, for approximately 20 minutes or until bottom of crust is light brown. Lastly, raise the lid and finish cooking pizza by turning burner under the cooking pan on high for about 2 minutes. This will insure the center of pizza gets brown. Then turn off heat, slice and serve directly from pan.

FRESH VEGETABLE STIR-FRY

Take a trip to the Orient with this easy, and healthy vegetable recipe. **Makes 4 - 6 servings.**

Ingredients

- 2 tablespoons oil
- 1 onion, cut into wedges
- 1 carrot, thinly sliced
- 2 cups broccoli, cut into small flowerets
- 1 red pepper, sliced
- 2 sticks celery, thinly sliced
- 1 cup snow peas
- 1/2 cup chicken broth

Preparation

Heat oil in a wok or saute pan, directly over a high heat. Add onion and cook 1 minute. Add carrot and broccoli and stir-fry 2 minutes, then add red pepper, celery and snow peas and continue cooking 1 minute more. Add chicken broth and toss vegetables until cooked to desired doneness.

ONION BLOSSOMS

Great served as a snack, or to dress up barbecued meats, poultry or fish. **Makes 4 servings.**

Ingredients

- 4 medium sweet onions (4-5 ounces each)
- 1 tablespoons margarine or butter, melted
- 1 teaspoon Dijon-style mustard
- 1/8 teaspoon hot pepper sauce
- 1 tablespoon brown sugar
- 1 pepper (optional)

Preparation

Peel onions, then cut almost completely through each onion, forming 8 wedges. Onion will be loose, but still be intact. Prepare four 12-inch squares of aluminum foil. Place one onion in the center of each foil square.

Stir margarine (or butter) with hot pepper sauce and drizzle over onions. Sprinkle with brown sugar. Then bring up two sides of foil square and double fold. Bring remaining corners up and completely enclose leaving enough space for steam to build.

Place wrapped onion blossoms on grill, directly over medium heat. Close lid and cook 15 to 25 minutes or until onions are nearly tender. Make a 2-inch opening at the top of each onion wrapping, then close lid and cook 5 to 10 minutes more, or until onions are lightly browned. Sprinkle with pepper if desired and serve warm.

GRILLED POTATO SKINS

Serve these crispy potatoes as a snack or side dish. We've included microwave instructions for a timesaving short cut. **Makes 12 servings.**

Ingredients

- 6 baking potatoes (about 8 ounces each)
- 3 tablespoons margarine or butter, melted
- 1/2 cup picante sauce
- 1 cup shredded cheddar cheese (4 ounces)
- 3 slices bacon, crisp-cooked and crumbled or use prepackaged bacon bits
- 1 chopped tomato (optional)
- 1 diced green onion (optional)
- 1/2 cup sour cream (optional)

Preparation

Puncture clean potatoes with a fork, wrap in aluminum foil and place directly over low to medium heat. Close lid and cook directly for 1 hour or until center is tender. OR - Microwave clean, punctured potatoes on high for 15 to 20 minutes, or until center tender. Allow cooked potatoes to cool then unwrap and discard foil.

Cut potatoes in half - lengthwise. Scoop out potato pulp (serve separately or discard.) Be sure to leave 1/4-inch thick potato shell remaining. Brush the inside of each potato shell with melted margarine. Spoon 2 teaspoons picante sauce into each potato shell, sprinkle with cheese and top with bacon.

Place prepared potato skins on grill, directly over medium heat. Close lid and cook for 8 to 10 minutes or until potato skins are crisp. Sprinkle each potato skin with tomato and green onion and then top with sour cream, if desired.

LIMITED WARRANTY

Grand Hall Enterprise Co., Ltd. warrants to the original owner of each Bakers & Chefs and Members Mark Gas Grill that it is free from defects in workmanship and materials under conditions of normal residential use. Grand Hall Enterprise Co., Ltd. will repair or replace warranty parts according to the list on page 2 of this manual. There will be a charge for shipping and handling.

The extent of any liability of Grand Hall Enterprise Co., Ltd. under this limited warranty is limited to repair or replacement. The limited warranty period is not extended by such repair or replacement. Grand Hall Enterprise Co., Ltd. is not liable for any labor or other costs related to the removal and/or installation of any Warranty Part, installation of replacement parts, product assembly, and/or delivery costs.

Grand Hall Enterprise Co., Ltd. requires reasonable proof of your date of purchase. Therefore, you should retain your sales slip or invoice and return the Grand Hall Enterprise Co., Ltd. Product Warranty Registration Card immediately.

This limited warranty does not apply to any damage due to transportation, installation, purchaser servicing, accident, abuse, fire, alteration of the product in any way, act of God, or failure to read and/or abide by any product warnings, or any parts or labor used to replace any part or parts covered under this limited warranty.

This limited Warranty is in lieu of any other express or implied Warranty that may apply to this product. This disclaimer of implied warranties may not apply to you because some states do not allow disclaimer of implied Warranties.

If you live in a state that does not allow disclaimer of implied Warranties, your state may allow a partial limitation of implied Warranties to limit the duration of such Warranties to the duration of an express Warranty. In such states the duration of the implied Warranties is hereby expressly limited to the duration of this Limited Warranty.

In no event, whether as a result of breach of Warranty or Contract, negligence, strict liability, or misrepresentation, will Grand Hall Enterprise Co., Ltd. be liable for any incidental and/or consequential damages. Grand Hall Enterprise Co., Ltd.'s liability is limited to the purchase price of the covered grill. This exclusion of liability is not allowed in some states. Therefore, this exclusion may not apply to you.

Grand Hall Enterprise Co., Ltd. does not assume, or authorize any other person to assume for Grand Hall Enterprise Co., Ltd. any liability from the sale of this product beyond that expressly set forth in this Limited Warranty.

This Limited Warranty gives you specific rights. The laws of your state may give you additional rights.

For Warranty Service, please call our Grill Information Center at 1-800-770-9769, Monday through Friday, 8:00 AM TO 4:30 PM CST.

Grand Hall Enterprise Co., Ltd.
9th Fl., No.298, Rueiguang Rd., Neihu,
Taipei, Taiwan (114)